

Table of Contents

	<u>Page #</u>	
General Information	1-9	A
Single Row Deep Groove Ball Bearings	10-42	B
Single Row Angular Contact Ball Bearings	43-59	C
Double Row Angular Contact Ball Bearings	60-65	D
Double Row Self-Aligning Ball Bearings	66-74	E
Single Row Cylindrical Roller Bearings	75-99	F
Double Row Cylindrical Roller Bearings	100-105	G
Double Row Spherical Roller Bearings	106-120	H
Spherical Roller Bearings for Shaker Screens and Other Vibratory Equipment	121-124	I
Spherical Roller Bearings for Mobile Cement Mixer Gearboxes	125-128	J
Spherical Plain Bearings	129-132	K
Tapered Roller Bearings	133-149	L
Thrust Ball Bearings	150-161	M
Spherical Roller Thrust Bearings	162-170	N
Insert Ball Bearings and Insert Ball Bearing Units	171-184	O
SAF Split Pillow Block Housings	185-194	P
Accessories of Roller Bearings	195-205	Q
Rolling Elements	206-209	R
General Index	210-212	S

ZVL-ZKL BEARINGS CORPORATION



A

General Headquarters:

805 South Girls School Road
Indianapolis, IN 46231-1133
PHONE: 317-481-2077 or 800-925-2101
FAX: 317-481-2087
WEBSITE: www.zklbearings.com

WARRANTY

In no event shall ZVL-ZKL Bearings Corporation be liable for loss of use or for any indirect, incidental, or consequential damages, including, but not limited to, consequential damages for personal injuries or delay.

No warranty shall apply to any product which has been subject to misuse, misapplication, neglect (including but not limited to improper maintenance and storage), accident, improper installation, any modification (including but not limited to use of unauthorized parts or attachments), or adjustment, or improper repair or lubrication. Misuse also includes, without implied limitation, deterioration in the product or part caused by chemical action, wear caused by the presence of abrasive materials, and improper lubrication.

ZVL-ZKL Bearings Corporation makes no warranty regarding the goods. ZVL-ZKL Bearings Corporation's sole obligation shall be limited to making available to Buyer any existing applicable warranty of the manufacturer or supplier of the goods which are the subject of a contract for sale (including without implied limitation warranties provided by any component manufacturers or suppliers) to the extent that ZVL-ZKL Bearings Corporation is authorized to do so by the manufacturer or supplier. It is expressly agreed that our liability for any damages arising out of or related to this transaction, or the use of products ordered through ZVL-ZKL Bearings Corporation's services, whether in contract or in tort, is limited strictly to the warranties provided by the manufacturer or supplier of the goods or products, if any.

In no event may any product be used in, incorporated into, or be sold to any ultimate user for use in any aircraft or in nuclear applications, without the express written authorization of an officer of ZVL-ZKL Bearings Corporation. Use of a product in nuclear applications or in any aircraft will void this limited warranty.

NOTE: Some special order items may be subject to a minimum order quantity.

Great care has been taken to assure the accuracy of the data compiled in this catalog; however, ZVL-ZKL Bearings Corporation does not assume any liability for errors or omissions.

Bearing Designation

A

ZVL-ZKL rolling bearings are designated according to CSN 02 4608. The designation consists of numerical and alphabetical symbols indicating the bearing type, size, and design, as shown in the schematic.

Basic Designation

Rolling bearings manufactured in the basic design are given a “basic designation,” which consists of the bearing type and size designation. The type designation is formed by a symbol indicating the bearing design (see 3 in the schematic) and by a symbol indicating the dimension series or the diameter series (see 4 and 5 in the schematic); e.g., types 223, 302, NJ22, 511, 62, 12, etc. The bearing size designation is formed by symbols indicating the nominal bore diameter d (see 6 in the schematic).

Bearings with the bore diameter $d < 10$ mm:

The digit separated by a slash or the last digit directly indicates the bore diameter in mm; e.g., 619/2, 624.

Bearings with the bore diameter $d = 10$ mm up to 17 mm:

The two digit number 00 indicates the bore $d = 10$ mm; e.g., 1200

The two digit number 01 indicates the bore $d = 12$ mm; e.g., 51101A

The two digit number 02 indicates the bore $d = 15$ mm; e.g., 3202

The two digit number 03 indicates the bore $d = 17$ mm; e.g., 6303

EXCEPTION: Separable single row ball bearing type E. The two-digit number directly indicates the bore diameter in mm; e.g., E17.

Bearings with the bore diameter $d = 20$ mm up to 480 mm:

The bore diameter is five times the last two-digit number; e.g., the bore diameter is $d = 20 \times 5 = 100$ mm for the bearing 1320.

EXCEPTION: Bearings with the bore $d = 22, 28$ and 32 mm. The two-digit number separated by a slash directly indicates the bore diameter in mm; e.g., 320/32AX.

Bearings with the bore diameter $d > 500$ mm:

The last three- or four-digit number preceded by a slash directly indicates the bore diameter in mm; e.g., 230/530M, NU 29/1060.

Complete Designation

Roller bearings manufactured in a different design from the basic design are designated by a “complete designation.” This consists of the basic designation and symbols that indicate a difference from the basic design. The symbols indicating a variation are added to the basic designation as prefixes or suffixes and may also be formed by several letters or figures. The most frequently used symbols indicating bearing variations from the basic design are shown in the schematic. The number in parentheses for individual groups corresponds to the position number in the schematic.

A

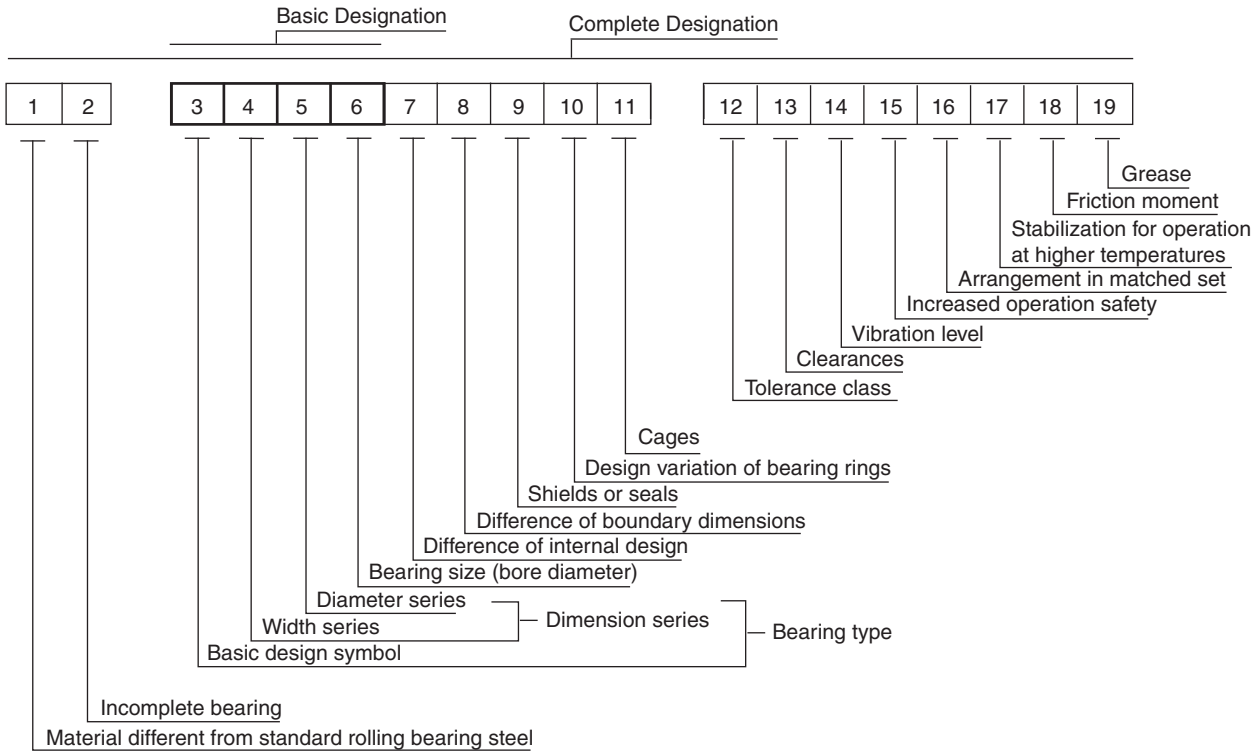

Bearing Nomenclature

Prefixes

Material Different from Standard Bearing Steel (1)

- X corrosion resisting steel; e.g., X 623
- T case hardened steel; e.g., T 32240

Incomplete Bearing (2)

- L removable ring of separable bearing; e.g., L NU206, for thrust ball bearings without shaft washer; e.g., L 51215
- R separable bearing without removable ring; e.g., R NU206 or R N310
- E single shaft washer of thrust roller bearing; e.g., E 51314
- W single housing washer of thrust ball bearing; e.g., W 51411
- K cage with rolling elements; e.g., K NU320

Suffixes

Difference of Internal Design (7)

- A single row angular contact ball bearing, contact angle $\alpha = 25^\circ$; e.g., B7205ATB P5
single row tapered roller bearing with higher load rating and higher limiting speed; e.g., 30206A
thrust ball bearing with higher limiting speed; e.g., 51105A
- AA single row angular contact ball bearing with contact angle $\alpha = 26^\circ$; e.g., B72010AATB P4
- B single row angular contact ball bearing with contact angle $\alpha = 40^\circ$; e.g., 7304B
single row tapered roller bearing with contact angle $\alpha > 17^\circ$; e.g., 32315B
- BE single row angular contact ball bearing with contact angle $\alpha = 40^\circ$, with new design;
e.g., 7310BETNG
- C single row angular contact ball bearing with contact angle $\alpha = 15^\circ$; e.g., B7202CTB P4
double row spherical roller bearing with C internal design construction; e.g., 22216C
- CA single row angular contact ball bearing with contact angle $\alpha = 12^\circ$; e.g., B7202CATB P5
- CB single row angular contact ball bearing with contact angle $\alpha = 10^\circ$; e.g., B7206CBTB P4
- D single row ball bearing, type 160 with higher load rating; e.g., 16004D E
single row cylindrical roller bearing with higher load rating; e.g., NU209E
double row spherical roller bearing with higher load rating; e.g., 22215E
spherical roller thrust bearing with higher load rating; e.g., 29416EJ

Difference of Boundary Dimensions (8)

- X change of boundary dimensions, introduced by new international standards; e.g., 32028AX

Shields or Seals (9)

- RS seal on one side; e.g., 6304 RS
- 2RS seals on both sides; e.g., 6204 2RS
- RSN seal on one side and snap ring groove in outer ring opposite to seal side; e.g., 6306 RSN
- RSNB seal on one side and snap ring groove in outer ring on the same side as seal; e.g., 6210 RSNB
- 2RSN seals on both sides and snap ring groove in outer ring; e.g., 6310 2RSN
- RSR seal on one side adhering to flat surface of inner ring; e.g., 624RSR
- 2RSR seals on both sides adhering to flat surface of inner ring; e.g., 608 2RSR
- Z metal shield on one side; e.g., 6206 Z
- ZZ metal shields on both sides; e.g., 6304 ZZ
- ZN metal shield on one side and snap ring groove in outer ring opposite to metal shield; e.g., 6208 ZN
- ZNB metal shield on one side and snap ring groove in outer ring on the same side as shield;
e.g., 6306 ZNB
- ZZN metal shields on both sides and snap ring groove in outer ring; e.g., 6208 ZZN
- ZR metal shield on one side adhering to flat surface of inner ring; e.g., 608 ZR
- ZZR metal shields on both sides adhering to flat surface of inner ring; e.g., 608 ZZR

Bearing Ring Design Variation (10)

K	tapered bore, taper 1:12; e.g., 1207K
K30	tapered bore, taper 1:30; e.g., 24048K30M
N	snap ring groove in outer ring; e.g., 6308N
NC	snap ring groove in the outer ring, same side as the filling slot; e.g., 3210NC
NS	snap ring groove in the center of the outer ring; e.g., 3203NS
NR	snap ring groove in outer ring and inserted snap ring; e.g., 6310NR
NX	snap ring groove in outer ring whose boundary dimensions do not correspond to STN 02 4605; e.g., 6210NX
D	split inner ring; e.g., 3309D
W33	groove and lubrication holes in bearing outer ring surface; e.g., 23148W33M
O	lubrication grooves in bearing outer ring; e.g., NU1014O

Cages (11)

Cage material for bearings in basic design is not usually indicated.

J	pressed steel cage, rolling element centered; e.g., 6034J
J2	pressed steel cage, rolling element centered, new design for single row tapered roller bearings; e.g., 30206AJ2
Y	pressed brass cage, rolling elements centered; e.g., 6001Y
F	machined steel cage, rolling elements centered; e.g., 6418F
L	machined light metal cage, rolling elements centered; e.g., NG180L C3S0
M	machined brass cage, rolling elements centered; e.g., NU330M
MB	machined brass cage guided on the inner ring; e.g., B7017AA MB
MD1	double row spherical roller bearing designed for special vibratory equipment application with two-piece outer ring riding brass cage
MHD1	double row spherical roller bearing designed for special vibratory equipment application with one-piece outer ring riding brass cage
T	machined cage made of textite, rolling elements centered; e.g., 6005T P5
TA	textite (fabric-reinforced phenolic resin) cage guided on the outer ring; e.g., A7201 AATA P5
TB	textite (fabric-reinforced phenolic resin) cage guided on the inner ring; e.g., B7203CBTB P4
TN	machined cage made of polyamide or similar plastic, rolling elements centered; e.g., 6207TN
TNG	machined cage made of polyamide or similar plastic with glass fibers, rolling elements centered; e.g., 2305TNG. (Suffix will be TNGN for ball thrust and double row self-aligning bearings.)

Cage design (these symbols are always used in connection with cage material symbols).

A	cage centered on outer ring; e.g., NU226MA
B	cage centered on inner ring; e.g., B7204CATB P5
P	machined window type cage; e.g., NU1060MAP
H	one-piece open-type cage; e.g., 629TNH
S	cage with lubrication grooves; e.g., NJ418MAS
V	bearing without cage, full rolling element number; e.g., NU209V

Tolerance Class (12)

P0	standard tolerance class (not indicated); e.g., 6204 P0
P6	higher tolerance class than normal; e.g., 6322 P6
P5	higher tolerance class than P6; e.g., 6201 P5
P5A	in some parameters higher tolerance class than P5; e.g., 6006TB P5A
P4	higher tolerance class than P5; e.g., B7204CBTB P4
P4A	in some parameters higher tolerance class than P4; e.g., B7205CATB P4A
P2	higher tolerance class than P4; e.g., B7205CATB P2
P6E	higher tolerance class for rotating electric machines; e.g., 6204 P6E
P6X	higher tolerance class for single row tapered roller bearings; e.g., 30210A P6X
SP	higher tolerance class for cylindrical roller bearings with tapered bore; e.g., NN3022K SPC2NA
UP	higher tolerance class than SP for cylindrical roller bearings with tapered bore; e.g., N1016 UPC1NA

Clearances (13)

- C2 clearance less than normal; e.g., 608 C2
- C0 normal clearance (not indicated); e.g., 6204
- C3 clearance greater than normal; e.g., 6310 C3
- C4 clearance greater than C3; e.g., NU320M C4
- C5 clearance greater than C4; e.g., 22330M C5
- NA radial clearance for bearings with non-interchangeable rings (always after radial clearance symbol); e.g., NU215 P63NA
- R radial clearance in non-standardized range (range in μm); e.g., 6210A R10-20
- A axial clearance in non-standardized range (range in μm); e.g., 3210 A20-30

Vibration Level (14)

- C6 reduced vibration level lower than normal (not indicated); e.g., 6304 C6
- C06 reduced vibration level lower than C6; e.g., 6205 C06
- C66 reduced vibration level lower than C06; e.g., 6207 C66

Note: Bearings in tolerance class P5 and higher have vibration level C6.

Increased Operation Safety (15)

- C7, C8, C9 - bearings with increased operation safety determined primarily for aircraft industry; e.g., 16008 C8

Symbol Combination (12 - 15)

Symbols for tolerance class, bearing internal clearances, vibration levels, and increased operation safety are combined when symbol C is omitted from the second and following special bearing characteristics; e.g.:

- | | |
|-------------------------|---------------------|
| P6 + C3 = P63 | e.g., 6211 P63 |
| P6 + C8 = P68 | e.g., 16002 P68 |
| C3 + C6 = C36 | e.g., 6303 2RS C36 |
| P5 + C3 + C9 = P539 | e.g., 6205MA P539 |
| P6 + C2NA + C6 = P626NA | e.g., NU1038 P626NA |

Bearing Arrangement in Matched Set (16)

Designation for bearings arranged in matched sets of two, three or four bearings consists of symbols indicating the bearing arrangement and symbols determining internal clearance, or preload of matched bearings. Besides symbols shown in the table, U indicates bearings can be universally matched; e.g., B7003CTA P4UL.

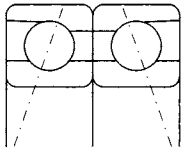
A

O

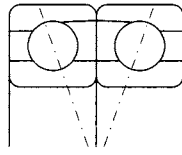

X

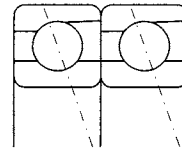

T

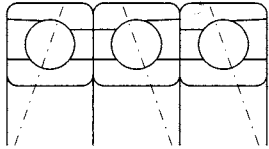

OT

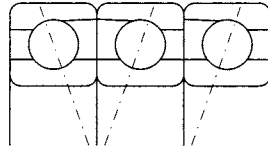

XT

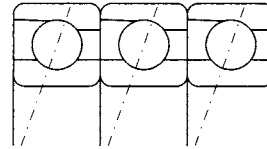

TT

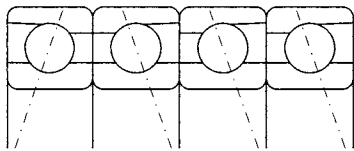

OTT

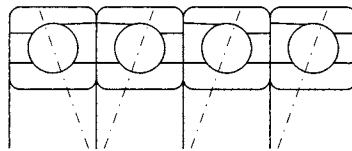

XTT

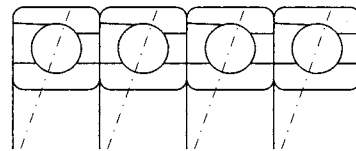

TTT

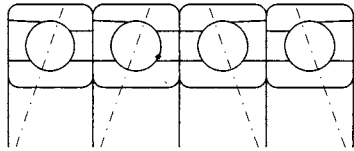

TOT

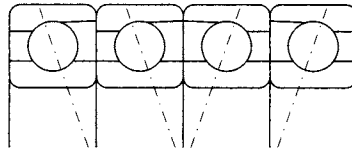

TXT

Internal Clearance or Preload

These symbols are always used in combination with matching symbols.

- A bearing matching with clearance; e.g., 7305OA
- O bearing matching without clearance; e.g., 7305 P6XO
- L bearing matching with light preload; e.g., B7205CATB P4UL
- M bearing matching with medium preload; e.g., B7204CATB P5XM
- S bearing matching with great preload; e.g., B7304AATB P4OS

Stabilization for Operation at Higher Temperature (17)

Both rings have stabilized dimensions for operation at higher temperature.

- S0 for operating temperature up to 302°F
- S1 for operating temperature up to 392°F
- S2 for operating temperature up to 482°F
- S3 for operating temperature up to 572°F
- S4 for operating temperature up to 662°F
- S5 for operating temperature up to 752°F

Designation example - NG160LB C4S3.

Friction Moment (18)

- JU reduced friction moment; e.g., 619/2 JU
- JUA bearings with determined friction moment for starting up; e.g., 623 JUA
- JUB bearings with determined friction moment for running out; e.g., 624 JUB

Grease (19)

For designation of bearings with shields or seals on both sides, filled with grease, symbol combinations are used. The first two symbols determine the operating temperature range. The third symbol (a letter) represents the name or type of lubricant, according to producer, or another symbol (a number) determines the grease volume.

TL	grease for low operating temperatures from -76°F to + 212°F; e.g., 6302 2RS TL
TM	grease for medium operating temperatures from -31°F to + 284°F; e.g., 6204 ZZR TM
TH	grease for high operating temperatures from -22°F to + 392°F; e.g., 6202 ZZ TH
TW	grease for both low and high operating temperatures from -40°F to +302°F; e.g., 6310 ZZ C4TW

A

Bearings According to Special Technical Terms

TPF	bearings produced according to special technical conditions per customer's request; e.g., bearing 6205MAP66 according to special technical conditions TPF 11142-71 is designated: 6205MA P66 TPF142
TPF99	double row spherical roller bearing for arrangements of railway vehicle axles; e.g., 23234 C3 TPF99
TPF204	single row ball bearings for fitting in kiln car wheels, etc.; e.g., 6308 TPF204
TPFK	bearings according to special technical conditions per customer's request, which have a large number of symbols indicating variations from the basic design; e.g., bearing NU1015 produced according to technical conditions TPFK 11137-70 is designated NU1015 TPFK137.

Bearings According to Special Drawing Documentation PLC

PLC A-BC-DE-F designation structure.

PLC	symbol for special rolling bearing
A	design group
0	single row ball bearing
1	double row ball bearing
2	thrust ball bearing
3	not occupied
4	single row cylindrical roller and spherical roller bearing
5	double and multi-row cylindrical roller and spherical roller bearing
6	single, double and four-row tapered roller bearing
7	special double row bearing
8	assembly units and separate parts
9	thrust cylindrical roller, spherical roller, and tapered roller bearing
BC	dimensional group - two digit symbols
DE	series number in dimensional group - two digit symbols
F	variation of design - one digit symbol

Single Row Deep Groove Ball Bearings

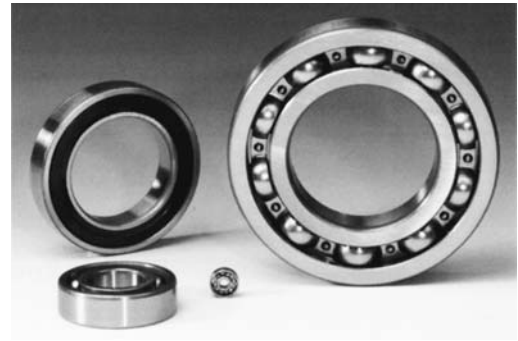

B

Single row deep groove ball bearings are the most common type of bearing. ZVL-ZKL offers a deep groove ball bearing that is non-separable and without filling slots. Relatively high load ratings are achieved by utilizing optimum size and number of balls for each bearing. These bearings will handle both radial and axial loads in either direction and are suitable for high rotational speeds.

ZVL-ZKL also offers a separable outer ring ball bearing, which is noted by the prefix “E” or “BO”. These bearings are produced with a bore up to 20 mm and are suitable for smaller loads and high rotational speeds.

Shielded or Sealed Bearings

Single row deep groove ball bearings can be produced with seals or shields. The shields (noted by a suffix of Z, ZZ, ZR, or ZZR) are produced from metal and create a non-contact sealing surface. The seals (noted by a suffix of RS, 2RS, RSR, or 2RSR) are produced by covering a vulcanised metal ring with a rubber material. The bearings are produced with contact seals; however, non-contact seals may be produced upon request. Our engineering staff is available for inquiries or information regarding our non-contact seals.

Bearings with double seals or shields are filled with grease and are lubricated for the life of the bearing. These bearings are good for a temperature range of -22°F to +250°F. Our standard grease is electric motor quality grease, Chevron SRI2, which exceeds the temperature rating of the bearing by approximately 97°. The bearings can be filled with other types of grease upon request.

Standard Shield Designs

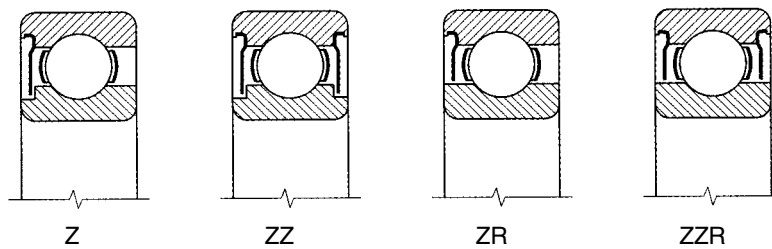

Standard Seal Designs

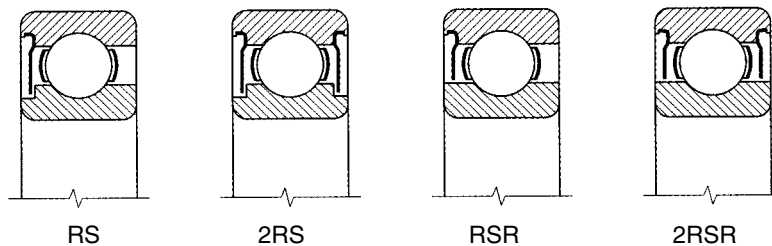

Cage

ZVL-ZKL single row deep groove ball bearings are produced with a pressed steel cage as standard production. Other styles of cages may be produced upon request, including but not limited to pressed brass, machined brass, polyamide (THN or TNB), and textite (TB) cages as well.

Boundary Dimensions

All boundary dimensions except for separable single row ball bearings (prefix of “E” or “BO”) comply with the standard ISO 15.

Tolerance

All single row deep groove ball bearings are produced in accordance to ABEC 1 or P0 tolerance class. Standard ISO 199 and ISO 492 specify these tolerances. These tolerance limits apply to all single row deep groove ball bearings except separable single row ball bearings (prefix “E” or “BO”). For these bearings the outer diameter has a limiting deviation of D+0.01/0.00 mm.

Radial Clearance

All ball bearings are offered in a range of radial clearances. The two standard radial clearances are C0 and C3. Other clearances may be produced upon request. All radial clearance values comply with standard ISO 5753 and are listed in the chart below.

Bore Diameter		Radial Clearance of Single Row Ball Bearings										Single Row Separable Ball Bearings Type E and BO	Radial Clearance	
d		C2		normal		C3		C4		C5			min	max
over	to	min	max	min	max	min	max	min	max	min	max			
mm		µm										µm		
2.5	10	0	7	2	13	8	23	14	29	20	37	E10, E12	15	30
10	18	0	9	3	18	11	25	18	33	25	45	E15	15	30
18	24	0	10	5	20	13	28	20	36	28	48	BO17, E17	25	45
24	30	1	11	5	20	13	28	23	41	30	53	E20	20	40
30	40	1	11	6	20	15	33	28	46	40	64			
40	50	1	11	6	23	18	36	30	51	45	73			
50	65	1	15	8	28	23	43	38	61	55	90			
65	80	1	15	10	30	25	51	46	71	65	105			
80	100	1	18	12	36	30	58	53	84	75	120			
100	120	2	20	15	41	36	66	61	97	90	140			
120	140	2	23	18	48	41	81	71	114	105	160			
140	160	2	23	18	53	46	91	81	130	120	180			
160	180	2	25	20	61	53	102	91	147	135	200			
180	200	2	30	25	71	63	117	107	163	150	215			

Vibration Level

All single row deep groove ball bearings are 100% checked for noise and vibration at the manufacturing facility. When special vibration levels are required, bearings with tolerance class P5 and special internal design changes can be produced. These bearings are noted by the designation C6, C06, or C66.

Tapered Bore

Single row deep groove ball bearings with tapered bores may be produced upon request. The standard taper is 1:12; the bearing can be mounted on adapter sleeves or directly on a tapered shaft.

Misalignment

Misalignment of bearings causes additional loading of the bearing and thus shortens its life. These bearings can take only a small amount of misalignment. Values of permissible misalignment at normal operating conditions are shown in this table:

Bearing Type	Load	
	Light ($F_r < 0.15C_{or}$)	Heavy ($F_r \geq 0.15C_{or}$)
618, 619, 160, 60	2' to 6'	5' to 10'
62, 63, 64	5' to 10'	8' to 16'

Radial Equivalent Dynamic Load

Single Row Ball Bearings:

$$P_r = XF_r + YF_a \quad (\text{kN})$$

F_a/C_{or}	Radial Clearance														
	Normal					C3					C4				
	$F_a/F_r \leq e$			$F_a/F_r > e$		$F_a/F_r \leq e$			$F_a/F_r > e$		$F_a/F_r \leq e$			$F_a/F_r > e$	
	e	X	Y	X	Y	e	X	Y	X	Y	e	X	Y	X	Y
0.025	0.22	1	0	0.56	2.0	0.31	1	0	0.46	1.75	0.4	1	0	0.44	1.42
0.04	0.24	1	0	0.56	1.8	0.33	1	0	0.46	1.62	0.42	1	0	0.44	1.36
0.070	0.27	1	0	0.56	1.6	0.36	1	0	0.46	1.46	0.44	1	0	0.44	1.27
0.13	0.31	1	0	0.56	1.4	0.41	1	0	0.46	1.30	0.48	1	0	0.44	1.16
0.25	0.37	1	0	0.56	1.2	0.46	1	0	0.46	1.14	0.53	1	0	0.44	1.05
0.5	0.44	1	0	0.56	1.0	0.54	1	0	0.46	1.0	0.56	1	0	0.44	1.0

Separable Single Row Ball Bearings:

$$P_r = F_r \quad \text{for } F_a / F_r \leq 0.2 \quad [\text{kN}]$$

$$P_r = 0.5 F_r + 2.5 F_a \quad \text{for } F_a / F_r > 0.2 \quad [\text{kN}]$$

Radial Equivalent Static Load

Single Row Deep Groove Ball Bearings:

$$P_{or} = 0.6 F_r + 0.5 F_a \quad (P_{or} = F_r) \quad [\text{kN}]$$

Separable Single Row Ball Bearings:

$$P_{or} = 0.9 F_r + 0.3 F_a \quad (P_{or} = F_r) \quad [\text{kN}]$$

Designation

Listed below are some common designations for our deep groove ball bearings.

Single Row Deep Groove Ball Bearings		
Suffix	Description	Example of Designation
RS	Seal on one side	6207 RS
RSR	Seal on one side adjacent to the smooth rib of the inner ring	6006 RSR
2RS	Seals on both sides	6306 2RS
2RSR	Seals on both sides adjacent to the smooth rib of the inner ring	6001 2RSR
Z	Shield on one side	6310 Z
ZR	Shield on one side adjacent to the smooth rib of the inner ring	6305 ZR
ZZ	Shields on both sides	6007 ZZ
ZZR	Shields on both sides adjacent to the smooth rib of the inner ring	608 ZZR
K	Tapered bearing bore at a 1:12 ratio	6208 K
N	Snap ring groove on the outer ring	6315 N
F	Machined steel cage guided on the rolling elements	6418 F
M	Machined brass cage guided on the rolling elements	6310 M
MA	Machined brass cage guided on the outer ring	6211 MA
T	Textite (fabric-reinforced phenolic resin) cage guided on the rolling elements	6005T P5
TN	Polyamide or similar plastic cage guided on the rolling elements	6207 TN
TNGH	Polyamide cage reinforced with glass fiber, guided on the rolling elements	6306 TNGH
Y	Pressed brass cage, rolling elements centered	6001 Y
P6	Higher tolerance class than normal	6202 P6
P6E	Higher tolerance class for rotating electrical machines	6206 P6E
P5	Higher tolerance class than P6	6005 P5
P4	Higher tolerance class than P5	607 P4
C2	Radial clearance less than normal	6000 C2
C3	Radial clearance greater than normal	6212 C3
C4	Radial clearance greater than C3	6314 C4
C5	Radial clearance greater than C4	6412M C5
R....	Radial clearance with a non-standard range (range in mm)	626 P5R5-15
A	Axial clearance with a non-standard range (range in mm)	624 P5A12-15
C6	Reduced vibration level	6206 C6
S0	Heat stabilized for an operating temperature up to 302°F (150°C)	6307M C4S0
S1	Heat stabilized for an operating temperature up to 392°F (200°C)	6307M C4S1
S2	Heat stabilized for an operating temperature up to 482°F (250°C)	6307M C4S2
S3	Heat stabilized for an operating temperature up to 572°F (300°C)	6307M C4S3
S4	Heat stabilized for an operating temperature up to 662°F (350°C)	6307M C4S4
S5	Heat stabilized for an operating temperature up to 752°F (400°C)	6307M C4S5
THD	Chevron SRI2 Grease	6204 2RS C3 THD

B

Single Row Deep Groove Ball Bearings

d = 2 to 17 mm

B

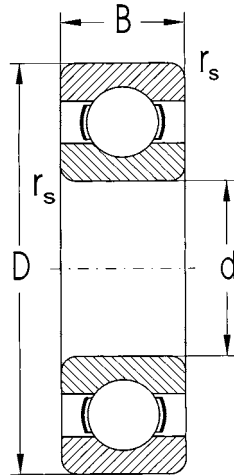

Dimension				Basic Load Rating				Limiting Speed for Lubrication with	
d	D	B	r _s min	Dynamic C _r	Static C _{or}	Dynamic C _r	Static C _{or}	Grease	Oil
mm				kN	kN	lbs.	lbs.	rpm	
2	6	2.3	0.1	0.271	0.091	60	20	63,000	79,000
3	10	4.0	0.15	0.490	0.216	110	48	40,000	50,000
4	13	5.0	0.2	0.900	0.414	202	93	38,000	45,000
	16	5.0	0.3	1.430	0.735	321	165	35,000	42,000
5	13	4.0	0.2	0.668	0.355	150	79	47,000	56,000
	16	5.0	0.3	1.430	0.735	321	165	35,000	42,000
	19	6.0	0.3	2.120	1.160	476	260	35,000	42,000
6	15	5.0	0.2	0.909	0.501	204	112	42,000	50,000
	19	6.0	0.3	2.120	1.160	476	260	35,000	42,000
7	19	6.0	0.3	2.200	1.160	494	260	35,000	42,000
	22	7.0	0.3	2.500	1.340	562	301	35,000	42,000
8	16	4.0	0.2	1.550	0.722	348	162	35,000	42,000
	22	7.0	0.3	2.500	1.340	562	301	35,000	42,000
9	24	7.0	0.3	2.800	1.530	629	343	35,000	42,000
	26	8.0	0.3	3.550	1.930	798	433	35,000	42,000
10	26	8.0	0.3	3.910	1.960	879	440	28,000	33,000
	30	9.0	0.6	5.110	2.660	1,148	597	25,000	30,000
	35	11.0	0.6	6.810	3.410	1,530	766	22,000	27,000
12	28	7.0	0.3	4.500	2.370	1,011	532	25,000	30,000
	28	8.0	0.3	4.500	2.240	1,011	503	25,000	30,000
	32	10.0	0.6	6.100	3.100	1,371	696	22,000	27,000
	37	12.0	1.0	8.580	4.220	1,928	948	20,000	24,000
15	32	8.0	0.3	5.210	2.820	1,080	631	21,000	25,000
	32	9.0	0.3	5.210	2.820	1,080	631	21,000	25,000
	35	11.0	0.6	7.100	3.730	1,580	841	20,000	24,000
	42	13.0	1.0	10.400	5.410	2,330	1,211	18,000	21,000
17	35	8.0	0.3	5.730	3.220	1,280	722	20,000	24,000
	35	10.0	0.3	5.730	3.220	1,280	722	20,000	24,000
	40	12.0	0.6	9.260	4.820	2,070	1,080	18,000	21,000
	47	14.0	1.0	13.100	6.560	2,930	1,440	16,000	19,000

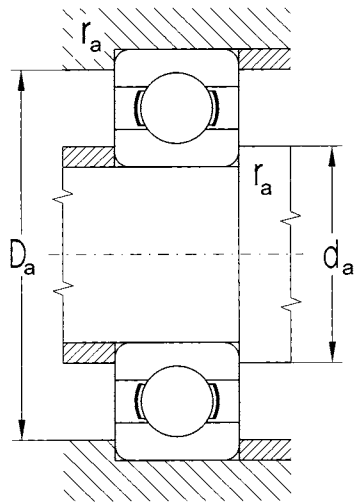

Bearing Designation	Abutment and Fillet Dimensions				Weight
	d	d _a min	D _a max	r _a max	
	mm				kg
619/2	2	3.2	4.8	0.1	0.0004
623	3	4.2	8.5	0.1	0.0015
624	4	5.6	11.2	0.2	0.0032
634		6.2	13.4	0.3	0.0050
619/5	5	6.6	11.5	0.2	0.0025
625		7.0	14.0	0.3	0.0047
635		7.2	15.8	0.3	0.0090
619/6	6	7.8	13.0	0.2	0.0040
626		8.2	17.0	0.3	0.0080
607	7	9.0	17.2	0.3	0.0075
627		9.2	19.0	0.3	0.0123
618/8TNH	8	9.8	14.0	0.2	0.0030
608		10.0	20.0	0.3	0.0120
609	9	11.0	22.0	0.3	0.0180
629		11.0	24.0	0.3	0.0200
6000	10	12.0	24.0	0.3	0.0190
6200		14.0	26.0	0.6	0.0310
6300		14.0	31.0	0.6	0.0540
16001	12	14.0	26.0	0.3	0.0200
6001		14.0	26.0	0.3	0.0220
6201		16.0	28.0	0.6	0.0370
6301		17.0	32.0	1	0.0610
16002	15	17.0	30.0	0.3	0.0270
6002		17.0	30.0	0.3	0.0300
6202		19.0	31.0	0.6	0.0460
6302		20.0	36.0	1	0.0850
16003	17	19.0	33.0	0.3	0.0320
6003		19.0	33.0	0.3	0.0400
6203		21.0	36.0	0.6	0.0730
6303		23.0	41.0	1	0.1150

Single Row Deep Groove Ball Bearings

d = 20 to 50 mm

B

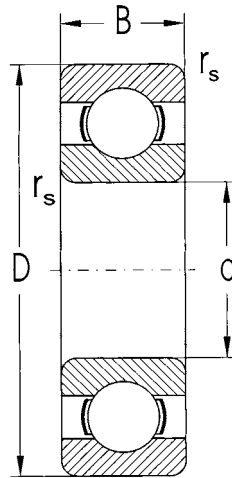

Dimension				Basic Load Rating				Limiting Speed for Lubrication with	
d	D	B	rs min	Dynamic Cr	Static Cor	Dynamic Cr	Static Cor	Grease	Oil
mm				kN	kN	lbs.	lbs.	rpm	
20	42	8	0.3	9.371	4.972	2,107	1,118	17,000	20,000
	42	12	0.6	9.371	4.972	2,107	1,118	17,000	20,000
	47	14	1.0	12.774	6.553	2,872	1,473	15,000	18,000
	52	15	1.1	15.886	7.811	3,567	1,756	14,000	17,000
25	47	8	0.3	6.950	4.550	1,562	1,023	14,000	17,000
	47	8	0.3	10.070	5.806	2,264	1,305	14,000	17,000
	47	12	0.6	10.070	5.806	2,264	1,305	14,000	17,000
	52	15	1.0	14.029	7.940	3,154	1,785	12,600	15,000
	62	17	1.1	21.123	10.806	4,749	2,429	11,000	13,000
	80	21	1.5	36.000	19.200	8,093	4,316	9,400	11,000
30	55	9	0.3	11.200	7.360	2,518	1,655	12,000	14,000
	55	13	1.0	13.243	8.250	2,977	1,855	12,000	14,000
	62	16	1.0	19.443	11.186	4,371	2,515	11,000	13,000
	72	19	1.1	29.701	15.678	6,677	3,525	10,000	12,000
	90	23	1.5	43.000	23.700	9,667	5,328	8,400	10,000
35	62	9	0.3	12.300	8.740	2,765	1,965	10,600	12,600
	62	14	1.0	15.956	10.328	3,587	2,322	10,600	12,600
	72	17	1.1	25.663	15.227	5,769	3,423	9,400	11,000
	80	21	1.5	33.367	19.230	7,501	4,323	8,400	10,000
	100	25	1.5	55.200	31.000	12,410	6,969	7,500	8,900
40	68	9	0.3	12.667	9.617	2,848	2,162	9,400	11,000
	68	15	1.0	16.824	11.493	3,782	2,584	9,400	11,000
	80	18	1.1	32.633	19.887	7,336	4,471	8,400	10,000
	93	23	1.5	40.760	24.170	9,163	5,434	7,900	9,400
	110	27	2.0	63.100	36.200	14,186	8,138	6,700	7,900
45	75	10	0.6	15.659	12.172	3,520	2,736	8,400	10,000
	75	16	1.0	21.100	15.300	4,743	3,440	8,400	10,000
	85	19	1.1	32.678	20.325	7,346	4,569	7,900	9,400
	100	25	1.5	52.804	31.715	11,871	7,130	7,100	8,400
	120	29	2.0	76.500	44.700	17,198	10,049	6,000	7,100
50	80	10	0.6	16.092	13.147	3,618	2,956	7,900	9,400
	80	16	1.0	21.720	16.650	4,883	3,743	7,900	9,400
	90	20	1.1	35.066	23.226	7,883	5,221	7,100	8,400
	110	27	2.0	61.754	37.754	13,883	8,487	6,300	7,500
	130	31	2.1	87.400	52.100	19,648	11,713	5,600	6,700

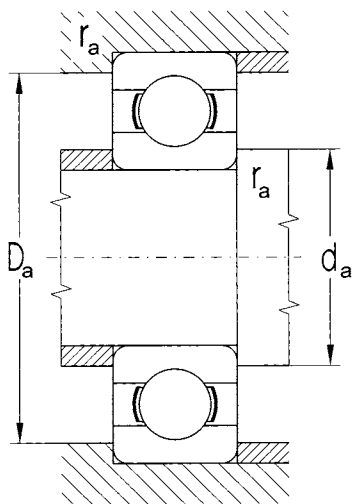

Bearing Designation	Abutment and Fillet Dimensions				Weight
	d	d _a min	D _a max	r _a max	
	mm				kg
16004D	20	22	40	0.3	0.050
6004		24	38	0.6	0.070
6204		25	42	1.0	0.108
6304		26	45	1.0	0.145
16005	25	27	43	0.3	0.053
16005D		27	43	0.3	0.530
6005		28	43	0.6	0.820
6205		30	47	1.0	0.129
6305		31	55	1.0	0.230
6405		34	70	1.5	0.530
16006	30	32	53	0.3	0.087
6006		34	50	1.0	0.119
6206		35	57	1.0	0.200
6306		36	65	1.0	0.331
6406		39	80	1.5	0.725
16007	35	37	60	0.3	0.111
6007		39.5	57	1.0	0.154
6207		42	65	1.0	0.284
6307		42	71	1.5	0.447
6407		44	90	1.5	0.954
16008	40	42	62	0.3	0.125
6008		44	63	1.0	0.191
6208		47	73	1.0	0.349
6308		47	81	1.3	0.625
6408		50	97	2.0	1.123
16009	45	49	71	1.0	0.170
6009		49	70	1.0	0.241
6209		52	78	1.0	0.404
6309		52	91	1.5	0.828
6409		55	107	2.0	1.540
16010	50	54	76	0.6	0.188
6010		54	75	1.0	0.260
6210		57	83	1.0	0.460
6310		60	100	2.0	1.060
6410		63	116	2.0	1.890

Single Row Deep Groove Ball Bearings

d = 55 to 90 mm

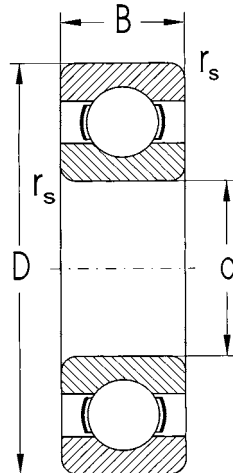

B

Dimension				Basic Load Rating				Limiting Speed for Lubrication with	
d	D	B	r _s min	Dynamic C _r	Static C _{or}	Dynamic C _r	Static C _{or}	Grease	Oil
mm				kN	kN	lbs.	lbs.	rpm	
55	90	11	0.6	19.300	16.200	4,339	3,642	7,100	8,400
	90	18	1.1	28.216	21.318	6,343	4,792	7,100	8,400
	100	21	1.5	43.350	29.397	9,746	6,609	6,700	8,400
	120	29	2.0	71.000	44.700	15,962	10,049	5,600	6,700
	140	33	2.1	100.000	61.900	22,481	13,916	5,300	6,300
60	95	11	0.6	22.000	19.200	4,946	4,316	6,700	7,900
	95	18	1.1	29.343	23.256	6,597	5,228	6,700	7,900
	110	22	1.5	52.846	35.789	11,880	8,045	6,000	7,100
	130	31	2.1	81.500	52.100	18,322	11,713	5,300	6,300
	150	35	2.1	110.000	69.400	24,729	15,602	4,700	5,600
65	100	11	0.6	21.200	19.600	4,766	4,406	6,300	7,500
	100	18	1.1	30.500	25.100	6,857	5,643	6,300	7,500
	120	23	1.5	57.210	40.011	12,861	8,995	5,300	7,500
	140	33	2.1	92.600	59.600	20,817	13,399	5,000	6,000
	160	37	2.1	117.950	78.329	26,516	17,609	4,500	5,300
70	110	13	0.6	27.600	25.100	6,205	5,643	5,600	6,700
	110	20	1.1	37.960	30.959	8,534	6,960	5,600	6,700
	125	24	1.5	62.000	43.800	13,938	9,847	5,300	6,300
	150	35	2.1	104.000	63.100	23,380	14,186	4,700	5,600
	180	42	3.0	144.000	104.000	32,373	23,380	4,000	4,700
75	115	13	0.6	28.700	26.600	6,452	5,980	5,300	6,300
	115	20	1.1	39.747	33.170	8,936	7,457	5,300	6,300
	130	25	1.5	66.179	49.311	14,878	11,086	5,000	6,000
	160	37	2.1	114.000	76.400	25,628	17,175	4,200	5,000
	190	45	3.0	152.525	112.922	34,289	25,386	3,800	4,500
80	125	14	0.6	32.900	31.600	7,396	7,104	5,000	6,000
	125	22	1.1	47.500	39.800	10,678	8,947	5,000	6,000
	140	26	2.0	72.200	53.100	16,231	11,937	4,700	5,600
	170	39	2.1	122.850	86.226	27,618	19,384	4,000	4,700
	200	48	3.0	163.587	124.984	36,776	28,098	3,500	4,200
85	130	14	0.6	34.100	32.900	7,666	7,396	4,700	5,600
	130	22	1.1	49.794	42.609	11,194	9,579	4,700	5,600
	150	28	2.0	83.299	63.675	18,726	14,315	4,200	5,000
	180	41	3.0	132.507	96.069	29,789	21,597	3,800	4,500
	210	52	4.0	174.000	136.000	39,117	30,574	3,300	4,000
90	140	24	1.5	58.400	49.200	13,129	11,061	4,500	5,300
	160	30	2.0	96.200	70.800	21,627	15,917	4,000	4,700
	190	43	3.0	144.000	108.000	32,373	24,279	3,500	4,200
	225	54	4.0	192.000	158.000	43,164	35,520	3,200	3,800

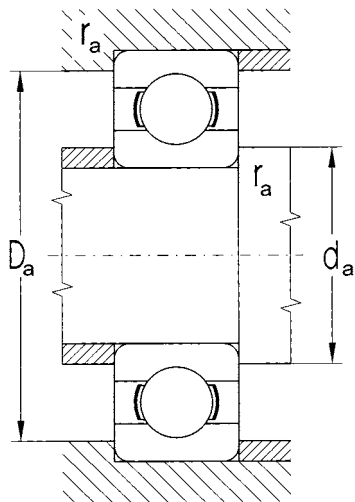

Bearing Designation	Abutment and Fillet Dimensions				Weight
	d	d _a min	D _a max	r _a max	
	mm				kg
16011	55	59	86	0.6	0.260
6011		60	84	1.0	0.383
6211		62	91	1.5	0.597
6311		65	110	2.0	1.380
6411		68	126	2.0	2.290
16012	60	64	91	0.6	0.285
6012		65	88	1.0	0.410
6212		67	101	1.5	0.771
6312		72	118	2.0	1.720
6412		73	136	2.0	2.760
16013	65	69	96	0.6	0.300
6013		70	93	1.0	0.437
6213		72	111	1.5	0.993
6313		76	128	2.0	2.100
6413		78	146	2.0	3.280
16014	70	74	106	0.6	0.433
6014		75	103	1.0	0.604
6214		77	116	1.5	1.070
6314		81	138	2.0	2.540
6414		85	164	2.5	4.850
16015	75	79	111	0.6	0.457
6015		80	108	1.0	0.640
6215		82	122	1.5	1.180
6315		86	148	2.0	3.060
6415		90	174	2.5	5.740
16016	80	84	121	0.6	0.597
6016		85	118	1.0	0.845
6216		90	130	2.0	1.400
6316		91	158	2.0	3.630
6416		95	184	2.5	6.720
16017	85	89	126	0.6	0.626
6017		90	123	1.0	0.892
6217		95	140	2.0	1.800
6317		98	166	2.5	4.200
6417		105	190	3.0	7.880
6018	90	96	132	1.5	1.170
6218		100	150	2.0	2.160
6318		103	176	2.5	4.950
6418		110	205	3.0	11.400

Single Row Deep Groove Ball Bearings

d = 95 to 170 mm

B

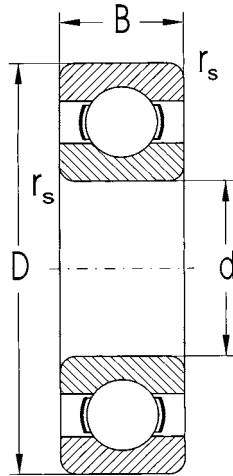

Dimension				Basic Load Rating				Limiting Speed for Lubrication with	
d	D	B	rs min	Dynamic Cr	Static Cor	Dynamic Cr	Static Cor	Grease	Oil
mm				kN	kN	lbs.	lbs.	rpm	
95	145	16	1.0	42.300	41.500	9,509	9,330	4,200	5,000
	145	24	1.5	60.700	54.100	13,646	12,162	4,200	5,000
	170	32	2.1	108.000	81.000	24,279	18,210	3,800	4,500
	200	45	3.0	152.444	117.366	34,271	26,385	3,300	4,000
100	150	16	1.0	44.000	43.800	9,892	9,847	4,200	5,000
	150	24	1.5	60.096	52.244	13,510	12,195	4,200	5,000
	180	34	2.1	123.000	92.600	27,652	20,817	3,500	4,200
	215	47	3.0	174.000	141.000	39,117	31,698	3,200	3,800
105	160	26	2.0	72.200	65.500	16,231	14,748	4,000	4,700
	190	36	2.1	132.927	104.833	29,883	23,568	3,300	4,000
	225	49	3.0	185.000	153.000	41,590	34,396	3,000	3,500
110	170	19	1.0	57.600	56.200	12,949	12,634	3,800	4,500
	170	28	2.0	82.500	72.200	18,547	16,231	3,800	4,500
	200	38	2.1	144.000	117.000	32,373	26,303	3,200	3,800
120	180	19	1.0	61.000	63.100	13,713	14,186	3,300	4,000
	180	28	2.0	85.000	79.400	19,109	17,850	3,300	4,000
	215	40	2.1	144.000	117.000	32,373	26,303	3,000	3,500
130	180	24	1.5	51.100	51.200	11,488	11,510	2,500	3,150
	200	33	2.0	106.986	99.667	24,052	22,406	3,200	3,800
	230	40	3.0	153.000	133.000	34,396	29,900	2,800	3,300
140	210	33	2.0	110.000	108.000	24,729	24,279	3,000	3,500
	250	42	3.0	166.000	150.000	37,318	33,722	2,500	3,000
150	225	24	1.1	92.600	98.100	20,817	22,054	2,700	3,200
	225	35	2.1	126.000	126.000	28,326	28,326	2,700	3,200
	270	45	3.0	190.000	181.000	42,714	40,691	2,200	2,700
170	260	42	2.1	168.000	171.000	37,768	38,443	2,200	2,700

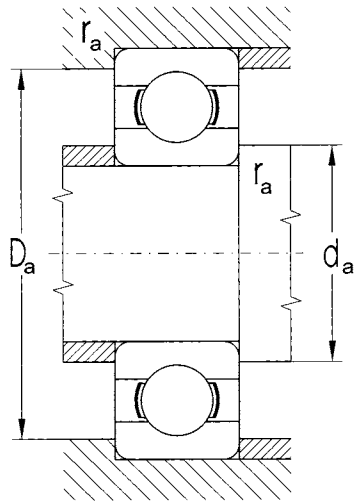

Bearing Designation	Abutment and Fillet Dimensions				Weight
	d	d _a min	D _a max	r _a max	
	mm				kg
16019	95	100	140	1.0	0.89
6019		102	137	1.5	1.22
6219		107	158	2.0	2.60
6319		109	186	2.5	5.72
16020	100	105	145	1.0	0.91
6020		106	142	1.5	1.27
6220		112	169	2.0	3.13
6320		113	201	2.5	7.07
6021	105	113	151	2.0	1.59
6221		117	178	2.0	3.74
6321		119	211	2.5	8.00
16022	110	115	165	1.0	1.46
6022		118	161	2.0	1.95
6222		122	188	2.0	4.37
16024	120	125	175	1.0	1.80
6024		128	171	2.0	2.10
6224		132	203	2.0	5.15
61926	130	137	172	1.0	1.86
6026		138	191	2.0	3.26
6226		144	216	2.5	6.20
6028	140	148	200	2.0	3.39
6228		154	236	2.5	7.56
16030	150				3.58
6030		159	213	2.0	4.16
6230		164	256	2.5	9.85
6034	170	179	248	2.0	6.91

Single Row Deep Groove Ball Bearings with Seals or Shields

d = 3 to 25 mm

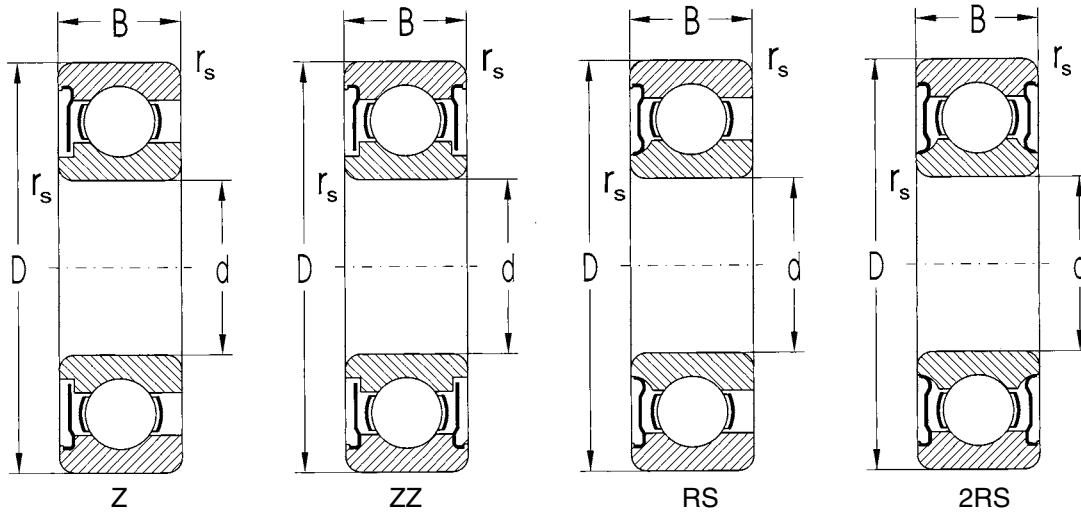

Dimension				Basic Load Rating				Bearing Designation			
d	D	B	rs min	Dynamic Cr	Static Cor	Dynamic Cr	Static Cor	Z, ZR	ZZ, ZZR	RS, RSR	2RS, 2RSR
mm				kN	kN	lbs.	lbs.				
3	10	4	0.15	0.490	0.216	110	49	623ZR	623ZZR	-	-
4	13	5	0.20	0.900	0.414	202	93	624ZR	624ZZR	-	-
	16	5	0.30	1.430	0.735	321	165	634ZR	634ZZR	-	-
5	16	5	0.30	1.430	0.735	321	165	625ZR	625ZZR	-	-
	19	6	0.30	2.120	1.160	477	261	635ZR	635ZZR	-	-
6	19	6	0.30	2.120	1.160	477	261	626ZR	626ZZR	-	-
7	19	6	0.30	2.200	1.160	495	261	607ZR	607ZZR	-	-
	22	7	0.30	2.500	1.340	562	301	627ZR	627ZZR	-	-
8	22	7	0.30	2.500	1.340	562	301	608ZR	608ZZR	608RSR	6082RSR
9	24	7	0.30	2.800	1.530	629	344	609ZR	609ZZR	609RSR	6092RSR
	26	8	0.30	3.550	1.930	798	434	629ZR	629ZZR	629RSR	6292RSR
10	26	8	0.30	3.910	1.960	879	441	6000ZR	6000ZZR	6000RSR	60002RSR
	30	9	0.60	5.110	2.660	1,149	598	6200ZR	6200ZZR	6200RSR	62002RSR
	35	11	0.60	6.810	3.410	1,531	767	6300ZR	6300ZZR	6300RS	63002RS
12	28	8	0.30	4.500	2.240	1,012	504	6001ZR	6001ZZR	6001RSR	60012RSR
	32	10	0.60	6.100	3.100	1,371	697	6201ZR	6201ZZR	6201RSR	62012RSR
	37	12	1.00	8.580	4.220	1,929	949	6301ZR	6301ZZR	6301RS	63012RS
15	32	9	0.30	5.210	2.820	1,171	634	6002ZR	6002ZZR	6002RS	60022RS
	35	11	0.60	7.100	3.760	1,596	845	6202Z	6202ZZ	6202RS	62022RS
	42	13	1.00	10.400	5.410	2,338	1,216	6302ZR	6302ZZR	6302RS	63022RS
17	35	10	0.30	5.730	3.220	1,288	724	6003ZR	6003ZZR	6003RS	90032RS
	40	12	0.60	9.260	4.820	2,082	1,084	6203Z	6203ZZ	6203RS	62032RS
	47	14	1.00	13.100	6.560	2,945	1,475	6303ZR	6303ZZR	6303RS	63032RS
20	42	12	0.60	9.440	5.010	2,122	1,126	6004ZR	6004ZZR	6004RS	60042RS
	47	14	1.00	12.800	6.560	2,878	1,475	6204Z	6204ZZ	6204RS	62042RS
	52	15	1.10	16.000	7.940	3,597	1,785	6304Z	6304ZZ	6304RS	63042RS
25	47	12	0.60	10.000	5.840	2,248	1,313	6005ZR	6005ZZR	6005RS	60052RS
	52	15	1.00	14.100	7.940	3,170	1,785	6205Z	6205ZZ	6205RS	62052RS
	62	17	1.10	20.700	11.200	4,654	2,518	6305Z	6305ZZ	6305RS	63052RS

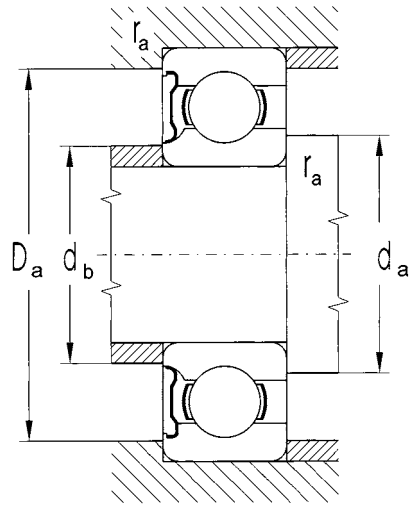

Limiting Speed for Lubrication with			Abutment and Fillet Dimensions					Weight
Grease Z, ZZ	RS, 2RS	Oil Z	d min	d_a max	d_b max	D_a max	r_a max	
rpm			mm					kg
40,000	-	50,000	3	4.2	4.8	8.5	0.1	0.002
38,000	-	45,000	4	5.5	5.8	11.2	0.2	0.004
35,000	-	42,000	5	6.2	6.5	13.4	0.3	0.005
35,000	-	42,000	5	7.0	7.0	14.0	0.3	0.006
35,000	-	42,000	5	7.2	7.5	15.8	0.3	0.009
35,000	-	42,000	6	8.2	8.3	17.0	0.3	0.010
35,000	-	42,000	7	9.0	9.0	17.0	0.3	0.010
35,000	-	42,000	7	9.2	9.8	19.5	0.3	0.012
35,000	24,000	42,000	8	10.0	10.0	20.0	0.3	0.015
35,000	24,000	42,000	9	11.0	12.0	22.0	0.3	0.018
35,000	24,000	42,000	9	12.0	12.5	22.5	0.3	0.020
28,000	19,000	33,000	10	12.0	12.5	24.0	0.3	0.020
25,000	17,000	30,000	10	14.0	14.4	26.0	0.6	0.032
22,000	15,000	27,000	10	14.0	15.0	31.0	0.6	0.053
25,000	17,000	30,000	12	14.0	14.5	26.0	0.3	0.022
22,000	15,000	27,000	12	16.0	16.5	28.0	0.6	0.037
20,000	13,000	24,000	12	17.0	17.0	32.0	1.0	0.060
21,000	14,000	25,000	15	17.0	18.0	30.0	0.3	0.031
20,000	13,000	24,000	15	19.0	19.5	31.0	0.6	0.045
18,000	12,000	21,000	15	20.0	20.5	36.0	1.0	0.082
20,000	13,000	24,000	17	19.0	20.0	33.0	0.3	0.040
18,000	12,000	21,000	17	21.0	21.4	36.0	0.6	0.065
16,000	10,600	19,000	17	23.0	23.0	41.0	1.0	0.116
17,000	11,000	20,000	20	24.0	24.5	38.0	0.3	0.070
15,000	10,000	18,000	20	25.0	25.5	42.0	0.6	0.108
14,000	9,400	17,000	20	26.0	26.5	45.0	1.0	0.145
14,000	9,000	17,000	25	28.0	29.0	43.0	0.6	0.081
12,600	8,400	15,000	25	30.0	30.5	47.0	1.0	0.128
11,000	7,500	13,000	25	31.0	33.0	55.0	1.0	0.232

Single Row Deep Groove Ball Bearings with Seals or Shields

d = 30 to 120 mm

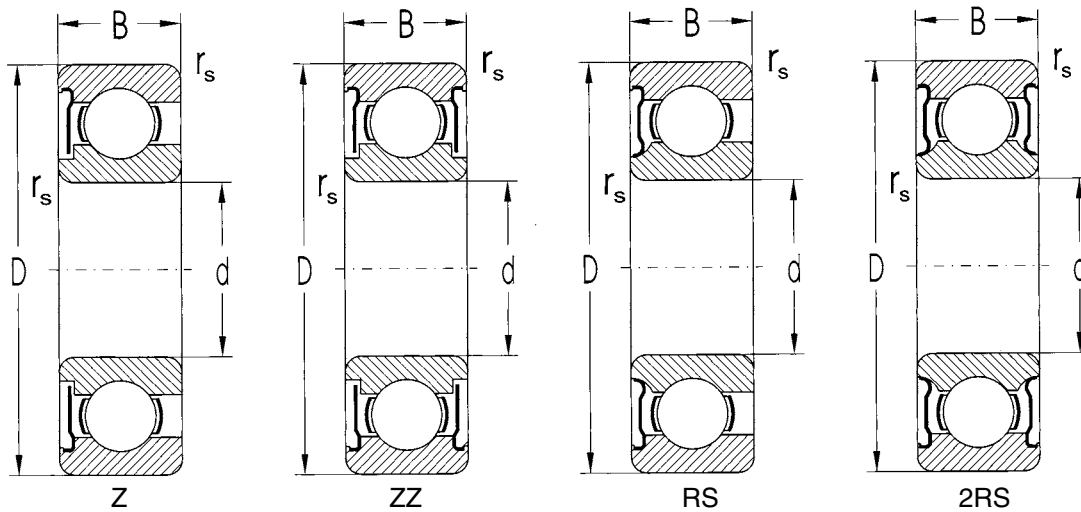

Dimension				Basic Load Rating				Bearing Designation			
d	D	B	r _s min	Dynamic C _r	Static C _{0r}	Dynamic C _r	Static C _{0r}	Z, ZR	ZZ, ZZR	RS, RSR	2RS, 2RSR
mm				kN	kN	lbs.	lbs.				
30	55	13	1.0	13.243	8.253	2,977	1,855	6006Z	6006ZZ	6006RS	60062RS
	62	16	1.0	19.443	11.186	4,371	2,515	6206Z	6206ZZ	6206RS	62062RS
	72	19	1.1	20.701	15.678	6,677	3,525	6306Z	6306ZZ	6306-RS	63062RS
35	62	14	1.0	15.956	10.328	3,587	2,322	6007Z	6007ZZ	6007RS	60072RS
	72	17	1.1	25.663	15.227	5,769	3,423	6207Z	6207ZZ	6207RS	62072RS
	80	21	1.5	33.367	19.230	7,501	4,323	6307Z	6307ZZ	6307RS	63072RS
40	68	15	1.0	16.824	11.493	3,782	2,584	6008Z	6008ZZ	6008RS	60082RS
	80	18	1.1	32.633	19.887	7,336	4,471	6208Z	6208ZZ	6208RS	62082RS
	90	23	1.5	40.760	24.017	9,163	5,399	6308Z	6308ZZ	6308RS	63082RS
45	75	16	1.0	21.100	15.300	4,743	3,440	6009Z	6009ZZ	6009RS	60092RS
	85	19	1.1	32.687	20.323	7,348	4,569	6209Z	6209ZZ	6209RS	62092RS
	100	25	1.5	52.804	31.715	11,871	7,130	6309Z	6309ZZ	6309RS	63092RS
50	80	16	1.0	21.720	16.650	4,883	3,743	6010Z	6010ZZ	6010RS	60102RS
	90	20	1.1	35.066	23.266	7,883	5,230	6210Z	6210ZZ	6210RS	62102RS
	110	27	2.0	61.754	37.745	13,883	8,485	6310Z	6310ZZ	6310RS	63102RS
55	90	18	1.1	28.216	21.318	6,343	4,792	6011Z	6011ZZ	6011RS	60112RS
	100	21	1.5	43.350	29.397	9,746	6,609	6211Z	6211ZZ	6211RS	62112RS
	120	29	2.0	71.000	44.700	15,962	10,049	6311Z	6311ZZ	6311RS	63112RS
60	95	18	1.1	29.343	23.256	6,597	5,228	6012Z	6012ZZ	6012RS	60122RS
	110	22	1.5	52.486	35.786	11,799	8,045	6212Z	6212ZZ	6212RS	62122RS
	130	31	2.1	81.500	52.100	18,322	11,713	6312Z	6312ZZ	6312RS	63122RS
65	100	18	1.1	30.500	25.100	6,857	5,643	6013Z	6013ZZ	6013RS	60132RS
	120	23	1.5	57.210	40.011	12,861	8,995	6213Z	6213ZZ	6213RS	62132RS
	140	33	2.1	92.600	59.600	20,817	13,399	6313Z	6313ZZ	6313RS	63132RS
70	110	20	1.1	37.960	30.959	8,534	6,960	6014Z	6014ZZ	6014RS	60142RS
	125	24	1.5	62.000	43.800	13,938	9,847	6214Z	6214ZZ	6214RS	62142RS
	150	35	2.1	104.000	68.100	23,380	15,310	6314Z	6314ZZ	6314RS	63142RS
75	115	20	1.1	39.747	33.170	8,936	7,457	6015Z	6015ZZ	6015RS	60152RS
	130	25	1.5	66.179	49.311	14,878	11,086	6215Z	6215ZZ	6215RS	62152RS
	160	37	2.1	114.000	76.400	25,628	17,175	6315Z	6315ZZ	6315RS	63152RS
80	125	22	1.1	47.500	39.800	10,678	8,947	6016Z	6016ZZ	6016RS	60162RS
	140	26	2.0	72.200	53.100	16,231	11,937	6216Z	6216ZZ	6216RS	62162RS
	170	39	2.1	122.850	86.226	27,618	19,384	6316Z	6316ZZ	-	63162RS
85	130	22	1.1	49.794	42.609	11,194	9,579	6017Z	6017ZZ	-	-
	150	28	2.0	83.299	63.675	18,726	14,315	6217Z	6217ZZ	6217RS	62172RS
	180	41	3.0	132.507	96.069	29,789	21,597	6317Z	6317ZZ	-	-
90	140	24	1.5	58.400	49.200	13,129	11,061	6018Z	6018ZZ	-	-
	160	30	2.0	96.200	70.800	21,627	15,917	6218Z	6218ZZ	-	-
	190	43	3.0	143.000	104.000	32,148	23,380	6318Z	6318ZZ	-	-
100	150	24	1.5	60.000	54.000	13,489	12,140	6020Z	6020ZZ	6020RS	60202RS
120	180	28	2.0	85.000	79.400	19,109	17,850	6024Z	6024ZZ	-	-

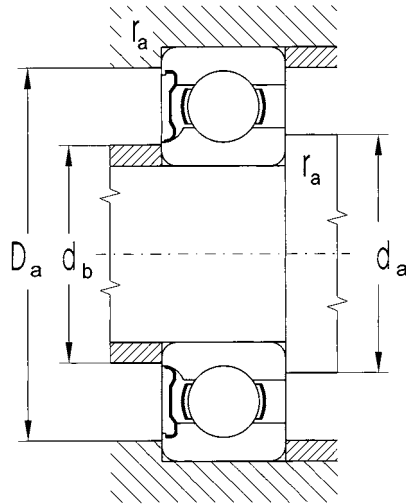

Limiting Speed for Lubrication with			Abutment and Fillet Dimensions					Weight
Grease Z, ZZ	RS, 2RS	Oil Z	d min	d _a max	d _b max	D _a max	r _a max	
rpm			mm					kg
12,000	7,900	14,000	30	34.0	35.0	50.0	1.0	0.1190
11,000	7,500	13,000		35.0	36.7	57.0	1.0	0.2010
10,000	6,700	12,000		36.0	38.9	65.0	1.0	0.3310
10,600	7,100	12,600	35	39.5	39.5	57.0	1.0	0.1540
9,400	6,300	11,000		42.0	42.0	65.0	1.0	0.2840
8,400	5,600	10,000		42.0	44.0	71.0	1.5	0.4470
9,400	6,300	11,000	40	44.0	46.0	63.0	1.0	0.1910
8,400	5,600	10,000		47.0	48.0	73.0	1.0	0.3490
7,900	4,700	9,400		47.0	50.6	81.0	1.5	0.6250
8,400	5,600	10,000	45	49.0	51.5	70.0	1.0	0.2410
7,900	5,300	9,400		52.0	52.5	78.0	1.0	0.4140
7,100	4,700	8,400		52.0	56.0	91.0	1.5	0.8280
7,900	5,300	9,400	50	54.0	56.5	75.0	1.0	0.2600
7,100	4,700	8,400		57.0	58.0	83.0	1.0	0.4640
6,300	4,200	7,500		60.0	61.8	100.0	2.0	1.0600
7,100	4,700	8,400	55	60.0	62.5	84.0	1.0	0.3830
6,700	4,500	8,400		62.0	65.0	91.0	1.5	0.5970
5,600	3,800	6,700		65.0	67.0	110.0	2.0	1.3800
6,700	4,500	7,900	60	65.0	68.0	88.0	1.0	0.4110
6,000	4,000	7,100		67.0	70.2	101.0	1.5	0.7710
5,300	3,500	6,300		72.0	75.0	118.0	2.0	1.7200
6,300	4,200	7,500	65	70.0	73.0	93.0	1.0	0.4370
5,300	3,500	7,100		72.0	77.0	111.0	1.5	0.9970
5,000	3,300	6,000		76.0	78.0	128.0	2.0	2.1000
5,600	3,800	6,700	70	75.0	78.0	103.0	1.0	0.6040
5,300	3,500	6,300		77.0	82.0	116.0	1.5	1.0700
4,700	3,200	5,600		81.0	85.0	138.0	2.0	2.5400
5,300	3,500	6,300	75	80.0	83.0	108.0	1.0	0.6400
5,000	3,300	6,000		82.0	85.0	121.0	1.5	1.1800
4,200	2,800	5,000		91.0	99.0	158.0	2.0	3.6200
5,000	3,300	6,000	80	85.0	90.0	118.0	1.0	3.0600
4,700	3,200	5,600		90.0	92.0	130.0	2.0	1.4000
4,000	-	4,700		91.0	99.0	158.0	2.0	3.6200
4,700	-	5,600	85	90.0	95.0	123.0	1.0	0.8920
4,200	2,800	5,000		95.0	99.0	140.0	2.0	1.8000
3,800	-	4,500		98.0	103.0	166.0	2.5	4.2600
4,500	3,000	5,300	90	97.0	100.0	132.0	1.5	1.1700
4,000	-	4,700		100.0	105.0	150.0	2.0	2.1600
3,400	-	4,200		103.0	108.0	176.0	2.5	5.1500
4,200	-	5,000	100	106.0	110.0	142.0	1.5	1.2700
3,300	2,200	4,000		120	128.0	132.0	171.0	2.0

Separable Single Row Ball Bearings

d = 10 to 20 mm

B

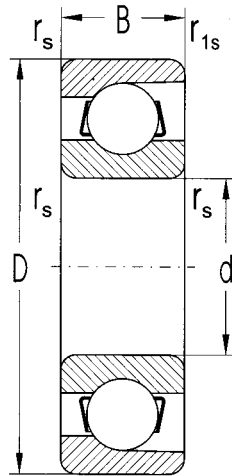

Dimension					Basic Load Rating				Limiting Speed for Lubrication with	
d	D	B	r _s min	r _{1s} min	Dynamic C _r	Static C _{or}	Dynamic C _r	Static C _{or}	Grease	Oil
mm					kN	kN	lbs.	lbs.	rpm	
10	28	8	0.3	0.15	6.448	2.914	1,450	655	25,000	31,000
12	32	7	0.3	0.15	3.410	0.722	767	162	22,000	28,000
15	35	8	0.3	0.15	4.470	0.981	1,005	221	20,000	24,000
	35	8	0.3	0.15	4.470	0.981	1,005	221	20,000	24,000
17	44	11	0.6	0.30	5.620	1.260	1,263	283	16,000	19,000
	44	11	0.6	0.30	8.910	2.030	2,003	456	14,000	17,000
20	47	12	1.0	0.60	8.910	2.030	2,003	456	14,000	17,000

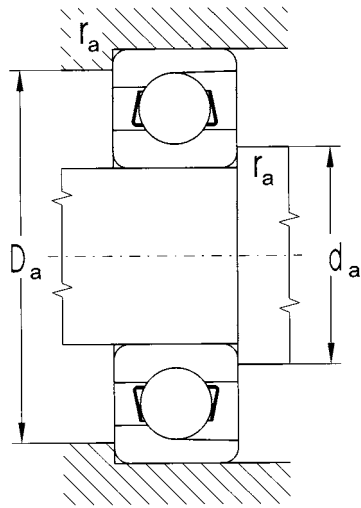

Bearing Designation	Abutment and Fillet Dimensions				Weight
	d	d_a min	D_a max	r_a max	
	mm				kg
E10Y	10	12.0	25.5	0.3	0.022
E12TNG	12	14.0	29.0	0.3	0.029
E15	15	17.2	31.8	0.3	0.034
E15Y		17.2	31.8	0.3	0.034
E17	17	22.0	39.0	0.6	0.079
BO17		22.0	39.0	0.6	0.075
E20	20	26.0	42.0	1.0	0.089

Single Row Deep Groove Ball Bearings - Inch Series

d = 1.125 to 1.500 inch

B

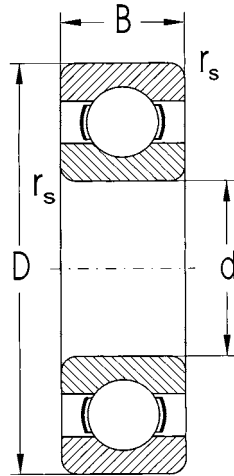

Dimension				Basic Load Rating				Limiting Speed for Lubrication with	
d	D	B	r_s min	Dynamic C_r	Static C_{or}	Dynamic C_r	Static C_{or}	Grease	Oil
in				kN	kN	lbs.	lbs.	rpm	
1.125	2.125	0.500	0.043	13.2	8.2	2,967	1,843	7,900	11,000
	2.125	0.500	0.043	13.2	8.2	2,967	1,843	7,900	-
	2.125	0.500	0.043	13.2	8.2	2,967	1,843	7,900	1,000
1.250	2.250	0.500	0.043	13.2	8.2	2,967	1,843	12,000	14,000
	2.250	0.500	0.043	13.2	8.2	2,967	1,843	12,000	-
	2.250	0.500	0.043	13.2	8.2	2,967	1,843	12,000	14,000
1.500	2.625	0.5625	0.043	16.8	11.4	3,777	2,563	6,300	11,000
	2.625	0.5625	0.043	16.8	11.4	3,777	2,563	6,300	-
	2.625	0.5625	0.043	16.8	11.4	3,777	2,563	6,300	11,000

Bearing Designation	Weight
	kg
R18	0.116
R182RS	0.116
R18ZZ	0.116
R20	0.210
R202RS	0.210
R20ZZ	0.210
R24	0.191
R242RS	0.191
R24ZZ	0.191

Single Row Deep Groove Ball Bearings for Special Applications

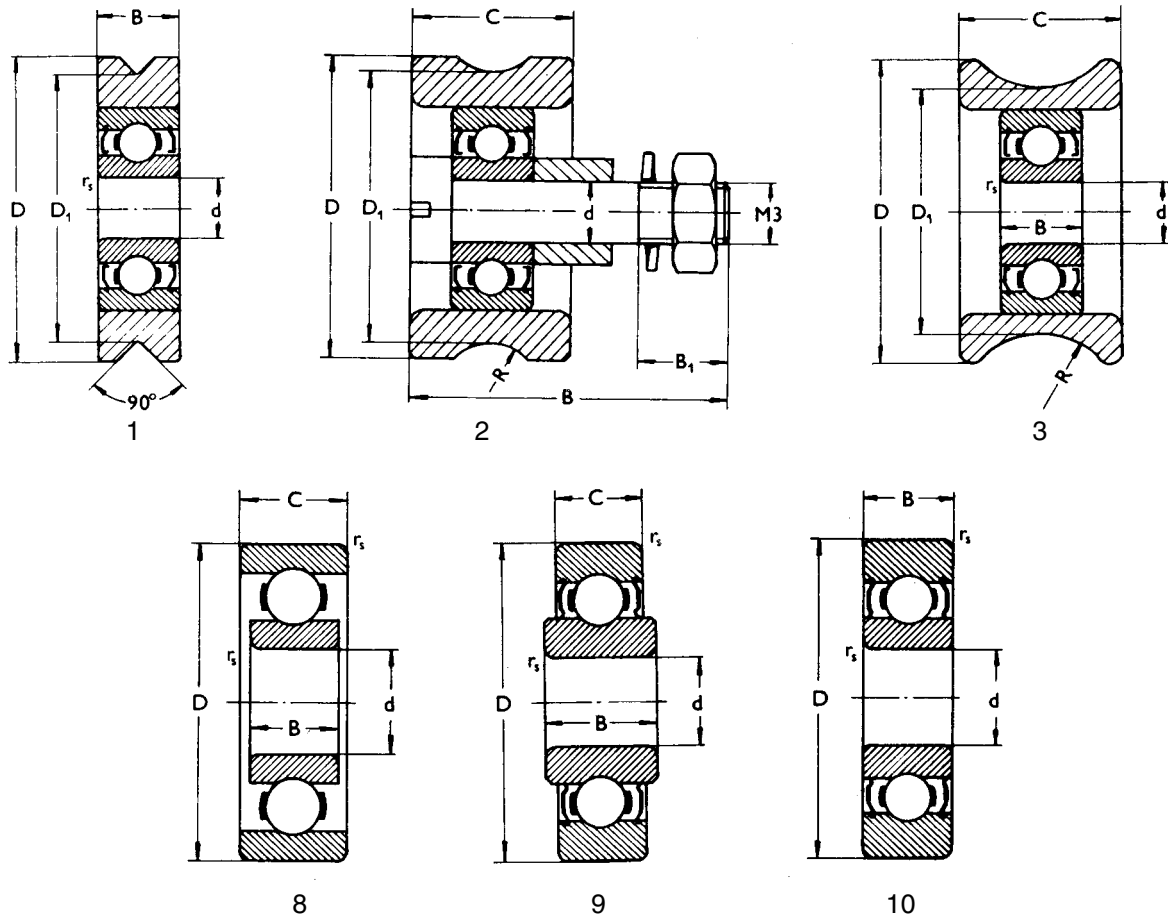

Dimension								Basic Load Rating			
d	D	B	C	r_s min	D_1	B_1	R	Dynamic C_r kN	Static C_{or} kN	Dynamic C_r lbs.	Static C_{or} lbs.
mm											
3	15	4.0	-	0.15	13.0	-	-	0.490	0.216	110	49
	15.15	16.0	8.0	-	13.237	4.5	2.45	0.490	0.216	110	49
	15.15	4.0	8.0	0.15	12.0	-	4.0	0.490	0.216	110	49
5	16	5.0	-	0.3	15.0	-	-	1.430	0.735	321	165
	16	5.0	-	0.3	14.9	-	2.0	1.430	0.735	321	165
6	48	6.0	-	-	-	7	0.3	2.070	0.944	465	212
7	19	6.0	-	0.3	-	-	-	2.200	1.160	495	261
	19	6.0	-	0.3	-	-	-	2.200	1.160	495	261
	19	18.0	-	-	-	10	0.3	2.820	1.080	634	243
8	22	7.0	-	0.3	21.1	-	-	2.500	1.340	562	301
	22	7.0	-	0.3	20.9	-	2.0	2.500	1.340	562	301
	24	7.0	8.5	0.3	-	-	-	1.260	0.944	283	212
	28	10.1	8.0	0.3	-	-	-	3.550	1.930	798	434
10	32	9.0	-	0.6	-	-	-	4.500	2.240	1,012	504
10.4	35	10.0	-	-	-	26	0.3	4.820	1.360	1,083	306
11.088	30	9.0	-	-	-	-	0.6	6.047	2.510	1,359	564

¹⁾ The bearing is intended for pendulum motions or low speed limits

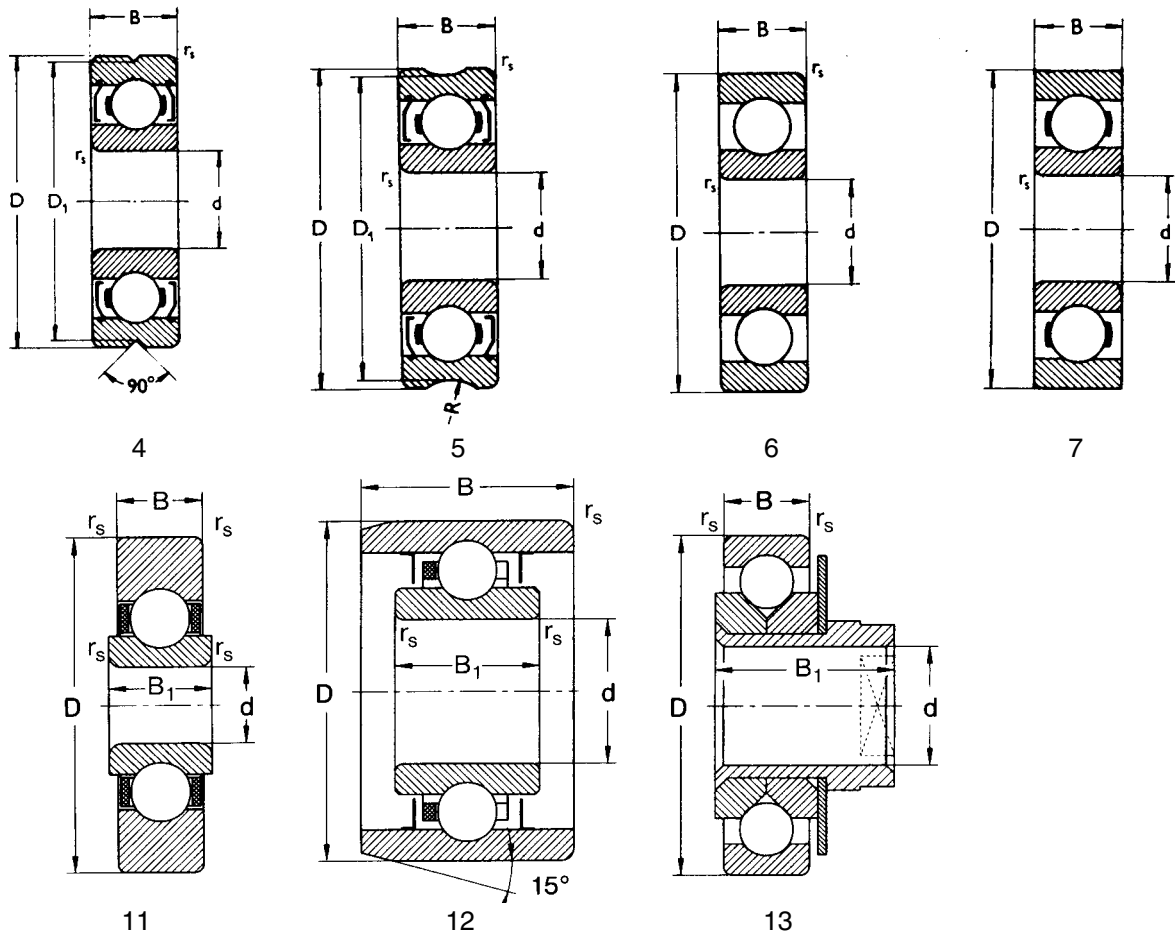

Limiting Speed for Lubrication with		Bearing Designation	Weight	Seals / Shields	Cage	Figure
Grease	Oil					
rpm			kg			
40,000	-	PLC 81-4	0.0025	ZZR	Y	1
40,000	-	PLC 81-1	0.0067	ZZR	Y	2
40,000	-	PLC 81-3	0.0052	ZZR	Y	3
35,000	-	PLC 01-17	0.0047	ZZR	Y, J	4
35,000	-	PLC 01-17-1	0.0046	ZZR	Y, J	5
20,000	24,000	PLC 03-78	0.0800	-	TNH	11
¹⁾ 35,000	-	PLC 01-15	0.0067	-	-	6
35,000	42,000	PLC 01-32	0.0075	-	Y, J	7
35,000	-	PLC 01-45	0.0158	ZZR	TNH	12
35,000	-	PLC 01-16	0.0115	ZZR	Y, J	4
35,000	-	PLC 01-16-1	0.0113	ZZR	Y, J	5
¹⁾ 24,000	-	PLC 02-4	0.0173	-	Y, J	8
24,000	-	PLC 02-12	0.0265	2RSR	J	9
17,000	-	PLC 03-21	0.0365	2RSR	J	10
12,600	17,000	PLC 03-79	0.0694	-	-	13
17,000	32,000	PLC 02-24	0.0310	2RS	TNG	10

Single Row Deep Groove Ball Bearings for Special Applications

B

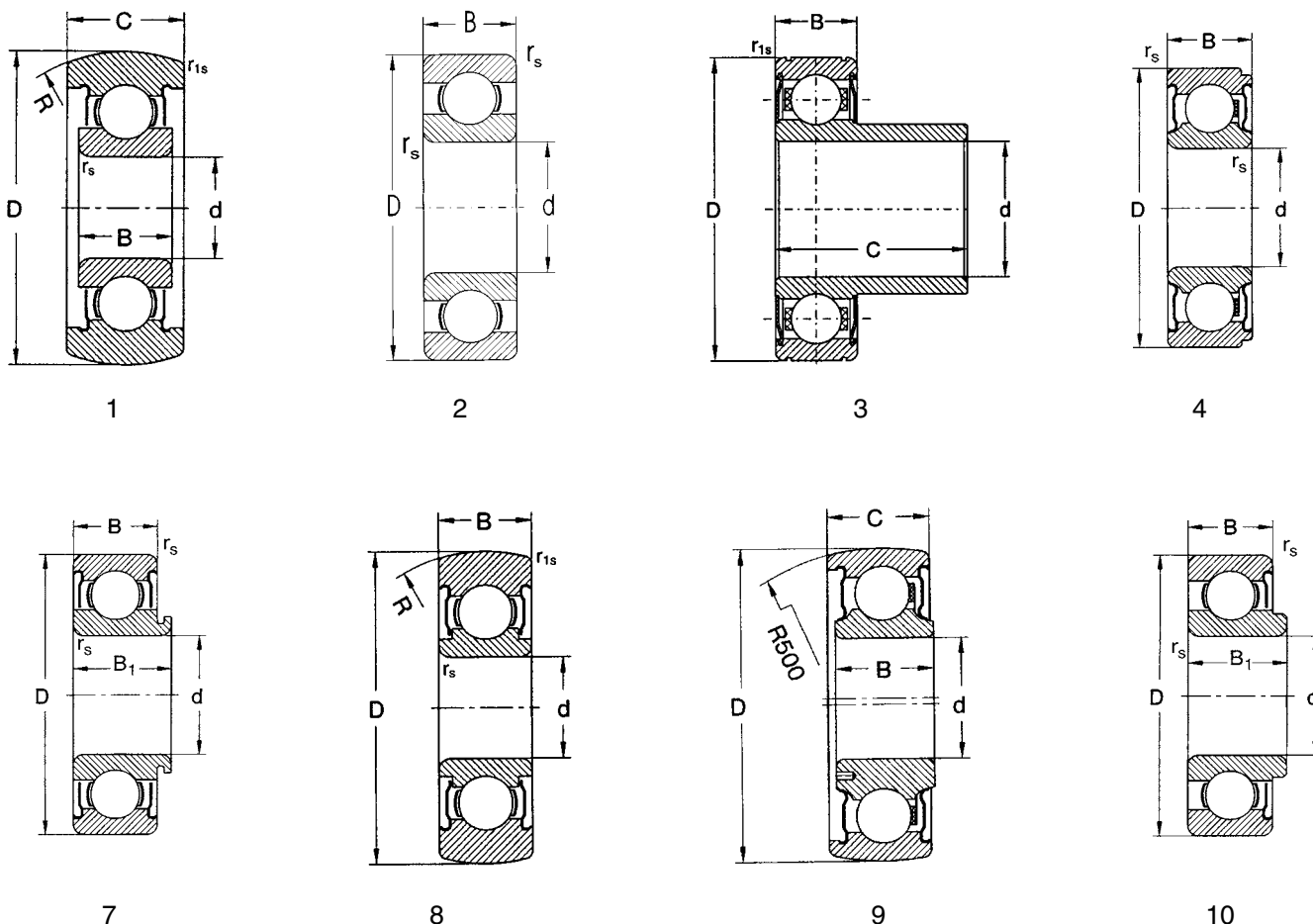

Dimension								Basic Load Rating			
d	D	B	C	rs min	D ₁	B ₁	R	Dynamic C _r	Static C _{or}	Dynamic C _r	Static C _{or}
mm								kN	kN	lbs.	lbs.
12	36	10.0	11.90	60.0	0.6	1.0	-	6.905	3.100	1,552	697
15	42	11.0	-	-	0.6	-	-	7.100	3.760	1,596	845
15.97	40	13.0	28.50	-	-	0.6	-	9.534	4.734	2,143	1,064
16	30	8.0	-	-	0.3	-	-	3.410	2.023	767	455
	40	12.0	14.00	-	0.6	0.6	-	9.534	4.743	2,143	1,066
17	30	10.0	-	-	0.3	-	8	5.400	2.480	1,214	558
	47	12.0	-	-	0.6	-	15	10.000	5.840	2,248	1,313
	47	12.0	-	47.0	0.6	-	-	9.260	4.820	2,082	1,084
	47	12.0	15.00	-	0.6	1.0	-	9.260	4.820	2,082	1,084
	47	12.0	15.00	-	1.0	0.6	-	9.260	4.820	2,082	1,084
20	56	18.0	19.60	-	-	-	-	14.100	7.940	3,170	1,785
	47	12.0	-	-	0.6	-	15	10.000	5.840	2,248	1,313
	51	15.0	-	-	1.1	-	-	16.000	7.940	3,597	1,785
	52	14.0	-	62.0	-	-	-	12.800	6.310	2,878	1,419
22	52	15.0	20.00	-	-	1.1	-	15.866	7.811	3,567	1,756
	48	36.0	-	-	0.5	-	-	22.800	14.200	5,126	3,192

¹⁾ This bearing is intended for oscillating motion or low frequency of rotation

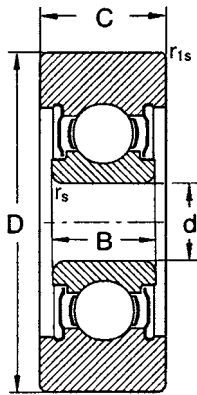

5

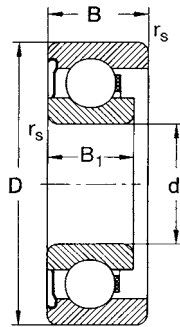

6

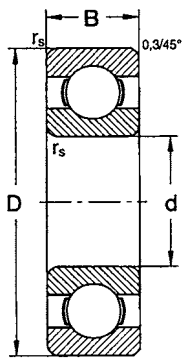

11

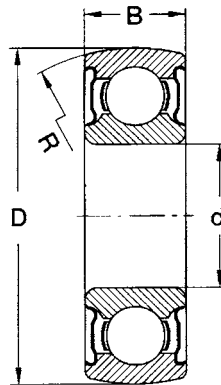

12

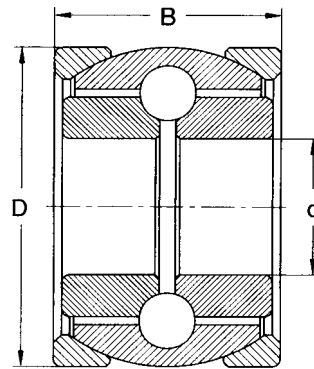

13

Limiting Speed for Lubrication with		Bearing Designation	Weight	Seals / Shields	Cage	Figure
Grease	Oil					
rpm			kg			
22,000	27,000	PLC 03-80	0.037	-	-	1
20,000	24,000	PLC 03-39	0.082	-	-	2
18,000	21,000	PLC 03-221	0.088	-	-	3
14,000	-	PLC 02-23	0.021	2RS	TNGH	4
18,000	21,000	PLC 03-223	0.073	-	-	5
13,000	21,000	PLC 02-35	0.020	RSR	TNG	6
14,000	-	PLC 03-53-2	0.104	ZZR	J	7
-	-	203ZZ	0.106	ZZ	-	8
18,000	-	PLC 03-06	0.117	-	-	5
18,000	-	PLC 03-52	0.110	-	-	5
8,200	-	PLC 04-53	0.240	-	-	9
14,000	17,000	PLC 03-53-1	0.105	ZR	J	10
14,000	17,000	PLC 04-30	0.126	-	-	11
9,500	-	PLC 04-200	0.117	-	-	12
14,000	17,000	PLC 05-17	0.145	-	-	3
1)	-	PLC 03-9-1	0.286	-	-	13

Single Row Deep Groove Ball Bearings for Special Applications

B

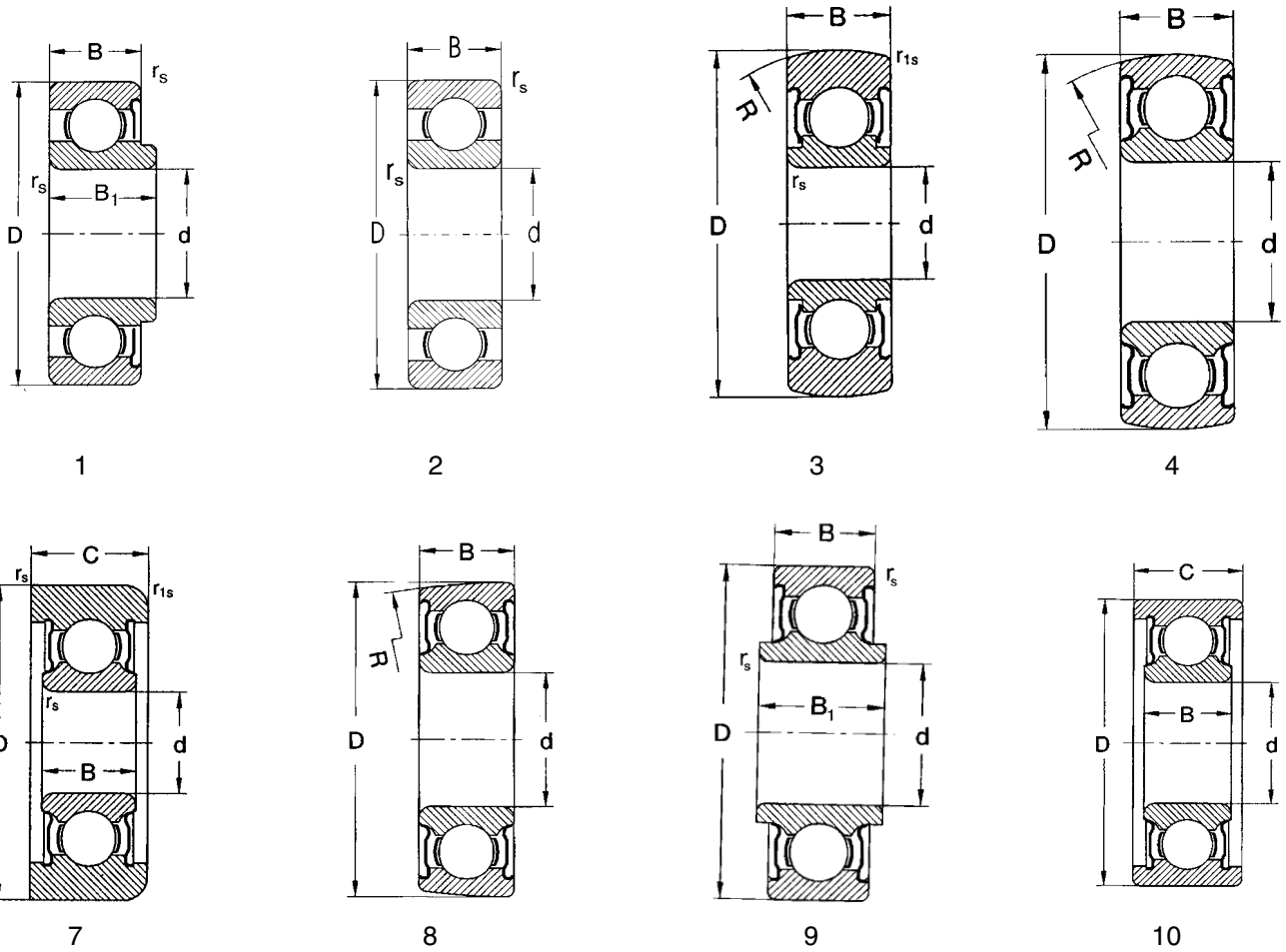

Dimension								Basic Load Rating			
d	D	B	C	r _s min	D ₁	B ₁	R	Dynamic C _r	Static C _{or}	Dynamic C _r	Static C _{or}
mm								kN	kN	lbs.	lbs.
25	47	12.0	-	-	0.6	-	15	10.000	5.840	2,248	1,313
	52	12.0	-	-	0.6	-	-	10.000	5.840	2,248	1,313
	62	12.0	-	-	0.6	-	-	19.600	11.200	4,406	2,518
	62	15.0	-	62.0	1.0	-	-	14.100	7.940	3,170	1,785
	62	15.0	-	62.0	-	-	-	14.100	7.080	3,170	1,592
	62	17.0	-	-	1.1	-	-	23.700	12.100	5,328	2,720
	62.5	15.0	-	62.5	1.0	0.6	-	16.443	11.186	3,697	2,515
	65	18.0	-	-	1.1	-	-	24.200	12.800	5,440	2,878
	75	17.0	-	-	1.2	-	-	31.600	17.400	7,104	3,912
	76.2	17.0	25.40	-	-	1.1	8.4	-	20.700	11.200	4,654
30	70	22.0	-	500.0	-	-	-	19.400	11.200	4,361	2,518
	70.15	20.0	-	500.0	-	-	-	19.600	13.700	4,406	3,080
	71.15	22.0	-	500.0	-	-	-	19.600	13.700	4,406	3,080
	72	16.0	-	72.0	-	-	-	19.600	10.000	4,406	2,248
	74.2	16.0	28.00	-	1.0	0.6	-	19.600	11.200	4,406	2,518
	75	21.0	-	-	-	-	-	29.800	15.800	6,699	3,552
	78	22.0	-	500.0	-	-	-	19.400	11.200	4,361	2,518
	78	22.0	-	500.0	-	-	-	19.600	13.700	4,406	3,080
	79	22.0	-	500.0	-	-	-	19.600	13.700	4,406	3,080
	80	37.0	18.00	-	-	-	-	32.900	20.000	7,396	4,496
82	19.0	29.00	-	-	-	-	30.000	15.800	6,744	3,552	
32	80	23.0	-	-	-	-	-	33.300	19.200	7,486	4,316
33.13	62	16.0	18.00	-	1.5	0.8	-	15.956	10.328	3,587	2,322
	62	16.0	18.00	-	1.5	0.8	-	15.956	10.328	3,587	2,322

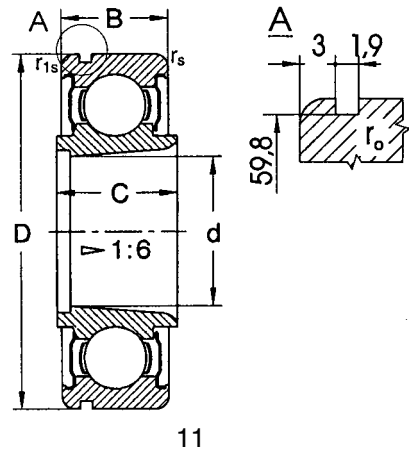
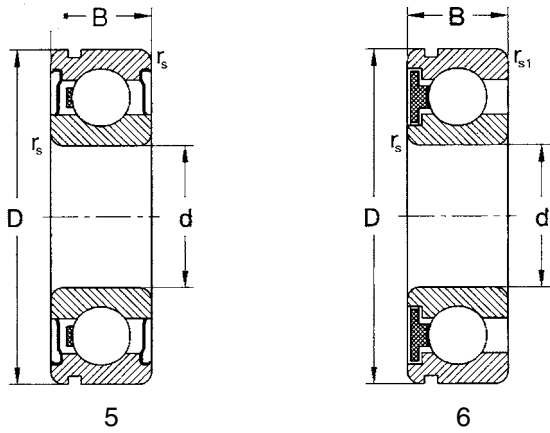

Limiting Speed for Lubrication with		Bearing Designation	Weight	Seals / Shields	Cage	Figure
Grease	Oil					
rpm			kg			
14,000	17,000	PLC 03-53	0.080	ZR	J	1
14,000	17,000	PLC 04-50	0.098	-	-	2
11,000	13,000	PLC 04-56	0.212	-	-	2
-	-	205ZZ	0.225	ZZ	-	3
8,200	-	PLC 04-201	0.225	-	-	4
10,500	-	PLC 04-48/1	0.225	2RS	TNGH	5
11,000	13,000	PLC 04-221	0.237	-	-	3
10,500	-	PLC 04-47/1	0.230	2RS	TNGH	5
10,000	12,000	PLC 05-12	0.660	-	TNGH	6
7,500	-	PLC 05-24	0.620	-	-	7
7,000	-	PLC 05-211	0.456	-	-	4
6,000	-	MR433	0.460	-	-	8
5,900	-	MR434	0.480	-	-	8
7,300	-	PLC 05-200	0.320	-	-	4
11,000	-	PLC 05-13	0.545	-	-	7
5,700	-	PLC 05-214	0.420	-	-	N/A
7,000	-	PLC 05-212	0.456	-	-	4
5,600	-	MR435	0.470	-	-	8
5,600	-	MR436	0.475	-	-	8
5,600	-	PLC 05-19	0.559	-	-	9
6,700	-	PLC 06-20	0.650	-	-	10
5,200	-	PLC 05-215	0.520	-	-	N/A
10,600	12,600	PLC 04-55	0.154	-	-	11
10,600	12,600	PLC 04-208	0.154	-	-	11

Single Row Deep Groove Ball Bearings for Special Applications

B

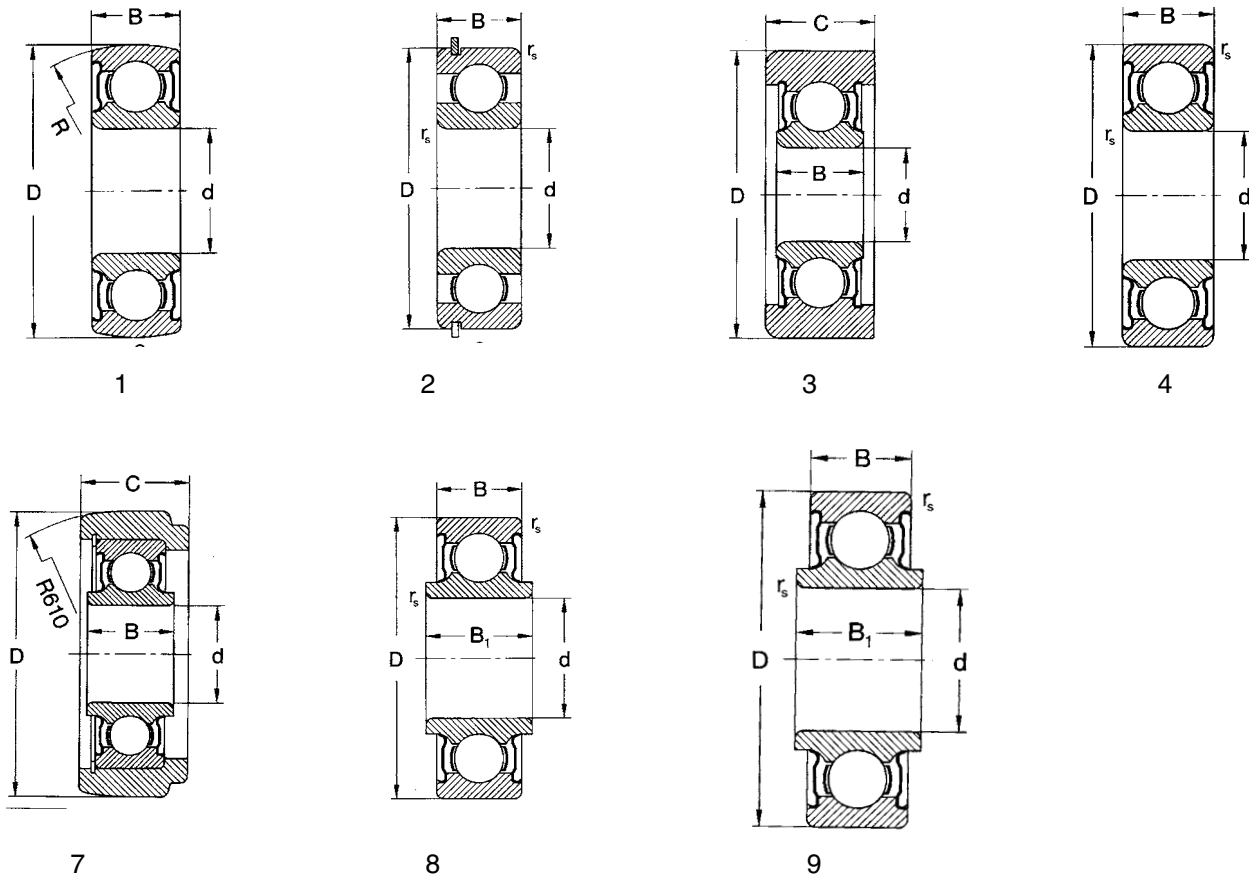

Dimension								Basic Load Rating			
d	D	B	C	r_s min	D_1	B_1	R	Dynamic C_r	Static C_{Or}	Dynamic C_r	Static C_{Or}
mm								kN	kN	lbs.	lbs.
35	72	17.0	-	200.0	-	-	-	16.000	10.200	3,597	2,293
	80	17.0	-	80.0	-	-	-	25.600	13.900	5,755	3,125
	80	17.0	-	-	1.1	-	-	25.600	15.300	5,755	3,440
	84.5	17.0	25.00	-	-	-	-	25.600	15.300	5,755	3,440
	85	17.0	-	-	1.1	-	-	25.600	15.300	5,755	3,440
	85	17.0	25.00	-	-	-	-	25.600	15.300	5,755	3,440
	85	23.0	-	-	-	-	-	33.300	19.200	7,486	4,316
	90	23.0	-	-	1.5	-	-	40.600	23.700	9,127	5,328
	91	20.0	31.85	-	-	-	-	25.600	15.300	5,755	3,440
	101.5	21.0	30.00	-	-	-	-	33.500	19.200	7,531	4,316
101.67	21.0	28.38	-	-	-	-	33.500	19.200	7,531	4,316	
110.8	20.0	30.15	-	-	-	-	25.600	15.300	5,755	3,440	
36	58	8.0	-	-	0.6	-	-	8.190	6.700	1,841	1,506
	65	8.0	-	-	0.6	-	-	8.190	6.700	1,841	1,506
40	72	17.0	-	-	-	-	22	16.800	11.400	3,777	2,563
	92	25.0	-	-	-	-	-	40.700	23.900	9,150	5,373
	114	23.0	28.00	-	-	-	-	40.600	23.700	9,127	5,328
	114	23.0	31.75	-	-	-	-	40.600	23.700	9,127	5,328
45	120	37.0	23.00	-	-	-	-	57.300	39.800	12,882	8,947
	127.06	24.5	31.75	-	-	-	-	53.100	31.600	11,937	7,104

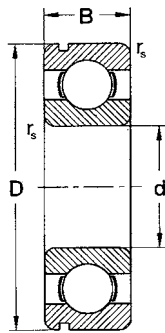

5

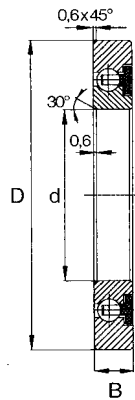

6

B

Limiting Speed for Lubrication with		Bearing Designation	Weight	Seals / Shields	Cage	Figure
Grease	Oil					
rpm			kg			
5,600	-	MR457	0.284	-	-	1
6,100	-	PLC 05-201	0.450	-	-	1
9,400	11,000	PLC 05-207	0.590	-	J	2
6,300	-	PLC 06-3-1	0.591	-	-	3
6,300	-	PLC 06-205	0.600	2RS	J	4
6,300	-	PLC 06-3	0.609	-	-	3
5,000	-	PLC 06-206	0.550	-	-	N/A
7,900	9,400	PLC 06-6-2	0.660	-	J	5
9,400	-	PLC 06-22	0.878	-	-	7
5,600	-	PLC 07-2	1.180	-	-	3
5,600	-	PLC 07-2-1	1.150	-	-	3
5,600	-	PLC 07-25	1.074	-	-	7
-	10,000	PLC 04-65-1	0.073	Z	TNGH	6
-	10,000	PLC 04-66-1	0.148	Z	TNGH	6
5,600	-	PLC 05-28	-	-	J	8
4,500	-	PLC 06-207	0.720	-	-	N/A
7,900	-	PLC 07-24	1.480	-	-	3
7,900	-	PLC 07-23	1.580	-	-	3
3,500	-	PLC 07-20	1.270	-	-	9
4,700	-	PLC 08-18	2.100	-	-	3

Single Row Deep Groove Ball Bearings for Special Applications

B

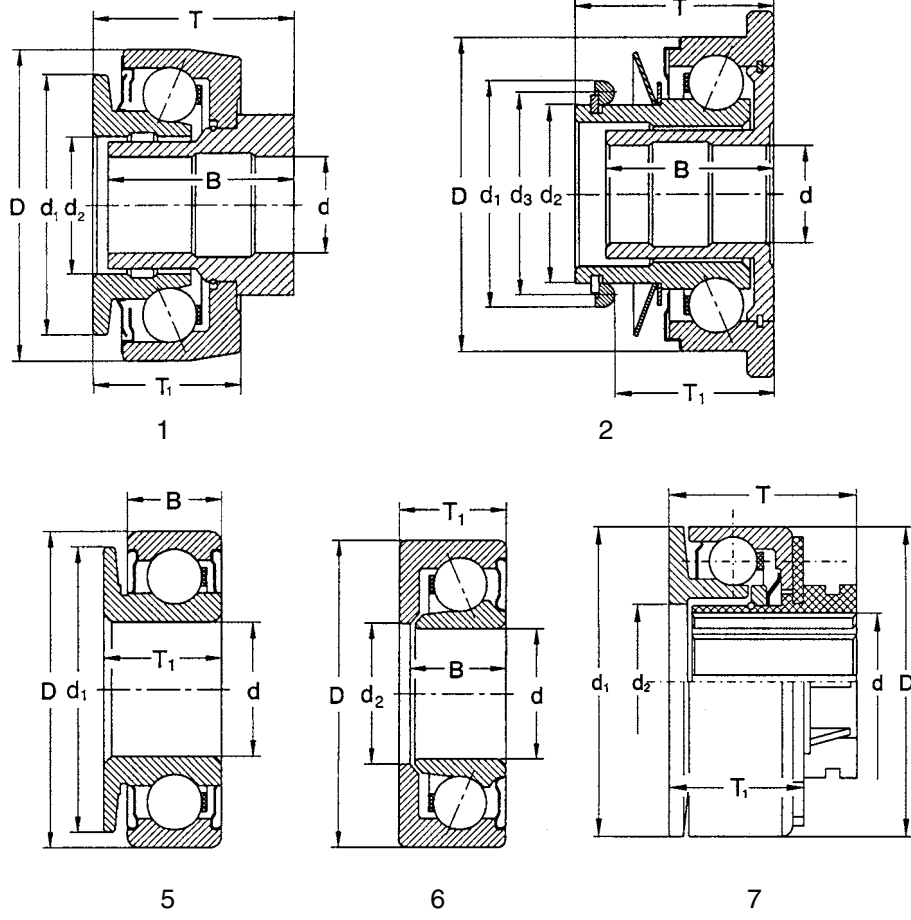

Dimension										Basic Load Rating			
d	D	T	d ₁	d ₂	d ₃	B	T ₁	r _s min	B ₁	Dynamic C _r kN	Static C _{0r} kN	Dynamic C _r lbs.	Static C _{0r} lbs.
mm													
45.2	94.5	50.5	95	57.0	-	16	31.5	-	-	20.300	16.300	4,564	3,664
50	80	-	-	53.0	-	16	20.0	-	-	21.723	16.650	4,884	3,743
55	100	-	-	-	-	33	-	1.1	55	43.000	29.300	9,667	6,587
57	102	56	95	64.6	-	53	37.0	-	-	23.700	19.200	5,328	4,316
62	115	56	102	76.0	-	53	37.0	-	-	27.600	23.300	6,205	5,238
	102	102	95	64.6	-	75	37.0	-	-	23.700	19.200	5,328	4,316
68	102	102	95	64.6	-	75	37.0	-	-	23.700	19.200	5,328	4,316
	115	58	102	76.4	-	55	39.0	-	-	27.600	23.300	6,205	5,238
71	128	51	106	90.0	100	42.5	33.5	-	-	33.500	27.600	7,531	6,205
	128	51	106	90.0	100	42.5	33.5	-	-	33.500	27.600	7,531	6,205
	128	69.7	106	90.0	100	42.5	52.0	-	-	33.500	27.600	7,531	6,205
	110	-	100	70.6	-	-	40.0	-	-	25.200	21.100	5,665	4,743
106	145	-	138	-	-	18	25.0	-	-	23.800	24.300	5,350	5,463

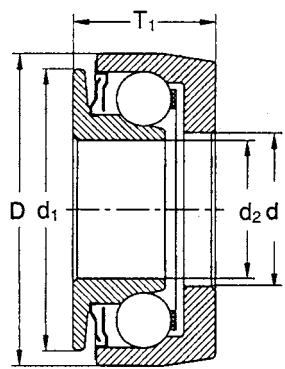

3

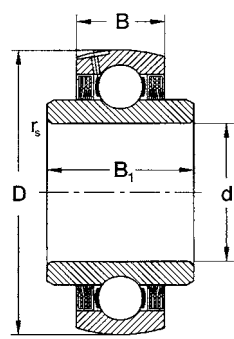

4

Limiting Speed for Lubrication with		Bearing Designation	Weight	Seals / Shields	Cage	Figure
Grease	Oil					
rpm			kg			
5,300	-	PLC 06-204	0.780	-	-	7
7,900	9,400	PLC 05-36	0.333	-	-	6
4,200	-	PLC 06-11	1.260	2RS	J	4
5,000	-	KZI-4	1.240	-	-	1
4,200	-	PLC 07-22	1.660	-	-	1
5,000	-	PLC 07-11	1.730	-	-	1
5,000	-	PLC 07-12	1.730	-	-	1
4,200	-	KZI-5	1.420	-	-	1
4,000	-	KZI/Z-5	1.880	-	-	2
4,000	-	KZI/Z-5/D	1.870	-	-	2
4,000	-	KZI/Z-5/L	2.380	-	-	2
4,400	-	KZI-4.5	1.180	-	-	3
2,500	-	PLC 08-13	0.940	-	-	5

Single Row Deep Groove Ball Bearings for Special Applications

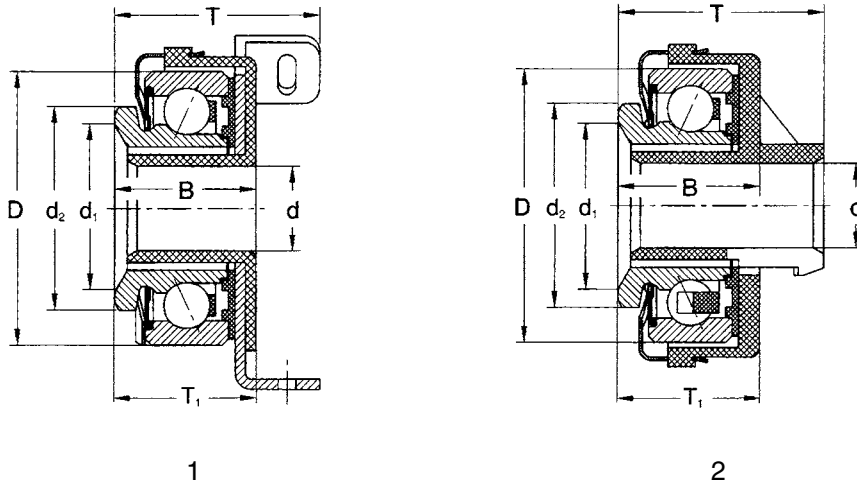

Dimension							Basic Load Rating			
d	D	B	d ₁	d ₂	T	T ₁	Dynamic C _r	Static C _{or}	Dynamic C _r	Static C _{or}
mm							kN	kN	lbs.	lbs.
25	54.4	22.5	40	43.5	36	21	12.300	7.790	2,765	1,751
	54.4	24.0	40	43.5	32	24	12.300	7.790	2,765	1,751

Limiting Speed for Lubrication with		Bearing Designation	Weight	Figure
Grease	Oil		kg	
rpm				
7,500	-	PLC 04-23	0.182	1
7,500	-	PLC 04-24	0.149	2

This page left blank intentionally.

Single Row Angular Contact Ball Bearings



C

Single row angular contact ball bearings are designed so that the connecting line of the raceway-to-ball contact points are positioned at an acute angle to the perpendicular line of the bearing axis or contact angle. Since this allows them to stand up to radial loads acting simultaneously with high axial forces in one direction, they are usually arranged back-to-back in pairs to accommodate axial loading in both directions. Optimum ball size and conformity give these bearings high load ratings. Although they have only a single rib on the bearing rings, single row angular contact bearings are non-separable.

Bearings with the designation B and BE have a contact angle of $\alpha=40^\circ$. Other designations such as AA with a contact angle of $\alpha=26^\circ$, and A with a contact angle of $\alpha=25^\circ$, are also produced.

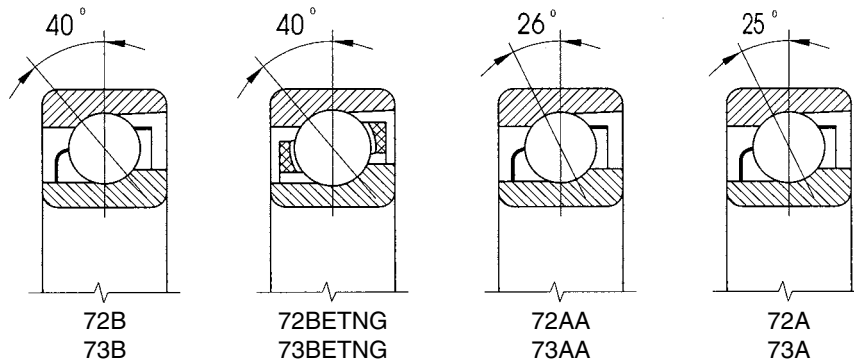

Single row angular contact bearings, type A70 and A72 or B70 and B72, are designed for high rotational speeds. They are different in internal design from the standard angular contact bearings. These bearings have designations CB (contact angle $\alpha=10^\circ$) and CA (contact angle $\alpha=12^\circ$). Often these bearings are produced with a higher tolerance class, P4 or P4A. Bearings with the C designation have a design with a contact angle of $\alpha=15^\circ$ and are often produced in a tolerance class P5 or P5A and P4 or P4A. These bearings, type A70 and A72 or B70 and B72, are predominately used in machine tool spindles and similar applications.

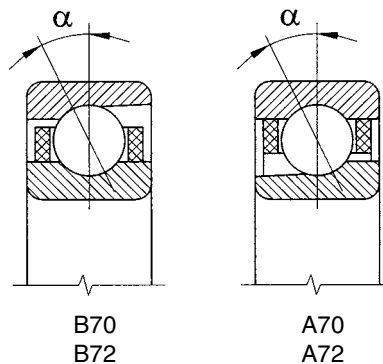

Cage

Bearing types 72 and 73 in B and AA design have a standard pressed steel cage. Bearing types 72 and 73 in BE design have a polyamide cage that is strengthened by glass fibers (TNG). Bearing types A70 and A72, which are designed for high rotational speeds, use a textite cage that is guided on the outer ring (TA). Bearing types B70 and B72 use a textite cage that is guided on the inner ring (TB). Other cage designs, such as brass, may be produced upon request.

Boundary Dimensions

Boundary dimensions comply with the standard ISO 15.

Tolerance

C

Single row angular contact ball bearings are generally produced in ABEC 1 or P0 tolerance class. When more demanding tolerances are needed, some higher tolerance levels can be produced. Standard ISO 199 and ISO 492 specify these tolerances.

Internal Clearance

Single row angular contact ball bearings are usually used in pairs. Suitable operating clearances or preload is adjusted during mounting and specified for the required application.

Bearing Arrangement in Pairs

Bearing types A70, A72, B70, and B72 are designed for high rotational speeds and are delivered in pairs.

Pair in “O” Arrangement (back to back)

This pairing is significant for its high rigidity and it withstands axial loads in both directions. It is used mostly to accommodate tilting moments. See picture below for arrangement drawing.

Pair in “X” Arrangement (face to face)

This pairing carries axial loads much like the “O” arrangement. The difference is that the rigidity for tilting moments is smaller.

Pair in “T” Arrangement (tandem)

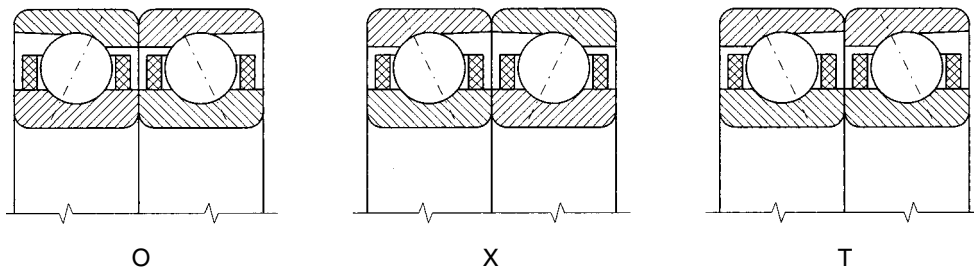

The “T” arrangement also has significant rigidity, but it can only carry axial loads in one direction.

Matched pairs “X” and “O” are delivered with light (L), medium (M), and heavy (S) preload. Designation for such a pair would look like this: B7204CBTB P4OL or A7201AATA P5XM.

Axial preload can be determined from this equation:

$$F_p = k C_r \cdot 10^{-2}$$

F_p -axial preload	[kN]
C_r -radial basic dynamic load	[kN]
k -axial preload factor according to the table	

Axial Preload		Factor k			
Magnitude	Designation	Contact Angle α			
		10°	12°	15°	26°
		Bearing Design			
		CB	CA	C	AA
Small	L	0.4	0.5	0.7	1.2
Medium	M	1.4	1.6	2.0	3.5
Heavy	S	2.8	3.2	4.0	7.0

Radial basic dynamic load rating of matched pair C_{rs} is :

$$C_{rs} = 1.62 \cdot C_r \quad [\text{kN}]$$

Radial basic static load rating of matched pair C_{ors} is:

$$C_{ors} = 2 \cdot C_{or} \quad [\text{kN}]$$

Values C_r and C_{or} are shown in the dimension tables.

Limiting rotational speed for matched pairs is smaller than for individual bearings. A pair with small preload (L) is reduced approximately 20%, medium preload (M) 35%, and heavy preload (S) 60%.

Bearings Matched in Sets of Three and Four Bearings

For special arrangements where high accuracy, high rigidity, high load ratings, and high rotational speed are required, matched sets of three and four bearings can be used.

Misalignment

Single row angular contact ball bearings do not accept misalignment. Any amount of misalignment can decrease the bearing's life drastically.

Radial Equivalent Static Load

Bearings with contact angle $\alpha = 40^\circ$:

Single bearings:

$$P_r = F_r \quad \text{for } F_a / F_r \leq 1.14 \quad [\text{kN}]$$

$$P_r = 0.35 F_r + 0.57 F_a \quad \text{for } F_a / F_r > 1.14 \quad [\text{kN}]$$

Bearings with contact angle $\alpha = 26^\circ$ and $\alpha = 45^\circ$:

Single bearings and matched pairs "T" arrangement:

$$P_r = F_r \quad \text{for } F_a / F_r \leq 0.68 \quad [\text{kN}]$$

$$P_r = 0.41 F_r + 0.87 F_a \quad \text{for } F_a / F_r > 0.68 \quad [\text{kN}]$$

Matched pairs "O" and "X" arrangement:

$$P_r = F_r + 0.92 F_a \quad \text{for } F_a / F_r \leq 0.68 \quad [\text{kN}]$$

$$P_r = 0.67 F_r + 1.14 F_a \quad \text{for } F_a / F_r > 0.68 \quad [\text{kN}]$$

Bearings with contact angle $\alpha = 15^\circ$:

Single bearings and matched pairs "T" arrangement:

$$P_r = F_r \quad \text{for } F_a / F_r \leq e \quad [\text{kN}]$$

$$P_r = 0.44 F_r + Y F_a \quad \text{for } F_a / F_r > e \quad [\text{kN}]$$

C

F_a/iC_{or}	e	Y
0.015	0.38	1.47
0.029	0.40	1.40
0.058	0.43	1.30
0.087	0.46	1.23
0.12	0.47	1.19
0.17	0.50	1.12
0.29	0.55	1.02
0.44	0.56	1.00
0.58	0.56	1.00

i - number of bearings
 C_{or} - radial basic load rating of individual bearing from dimensional tables [kN]

Matched pairs "O" and "X" arrangement:

$$P_r = F_r + Y_1 \cdot F_a \quad \text{for } F_a / F_r \leq e \quad [\text{kN}]$$

$$P_r = 0.72 F_r + Y_2 \cdot F_a \quad \text{for } F_a / F_r > e \quad [\text{kN}]$$

F_a/C_{or}	e	Y_1	Y_2
0.015	0.38	1.65	2.39
0.029	0.40	1.57	2.28
0.058	0.43	1.46	2.11
0.087	0.46	1.38	2.00
0.12	0.47	1.34	1.93
0.17	0.50	1.26	1.82
0.29	0.55	1.14	1.66
0.44	0.56	1.12	1.63
0.58	0.56	1.12	1.63

Bearings with contact angle $\alpha = 12^\circ$:
 Single bearings and matched pairs "T" arrangement:

$$P_r = F_r \quad \text{for } F_a / F_r \leq e \quad [\text{kN}]$$

$$P_r = 0.45 F_r + Y F_a \quad \text{for } F_a / F_r > e \quad [\text{kN}]$$

F_a/iC_{or}	e	Y
0.014	0.30	1.81
0.029	0.34	1.62
0.057	0.37	1.46
0.086	0.41	1.34
0.11	0.45	1.22
0.17	0.48	1.13
0.29	0.52	1.04
0.43	0.54	1.01
0.57	0.54	1.00

i - number of bearings
 C_{or} - radial basic load rating of individual bearing from dimensional tables [kN]

Matched pairs "O" and "X" arrangement:

$$P_r = F_r + Y_1 \cdot F_a \quad \text{for } F_a / F_r \leq e \quad [\text{kN}]$$

$$P_r = 0.74 F_r + Y_2 \cdot F_a \quad \text{for } F_a / F_r > e \quad [\text{kN}]$$

F_a/C_{or}	e	Y_1	Y_2
0.014	0.30	2.08	2.94
0.029	0.34	1.84	2.63
0.057	0.37	1.69	2.37
0.086	0.41	1.52	2.18
0.11	0.45	1.39	1.98
0.17	0.48	1.30	1.84
0.29	0.52	1.20	1.69
0.43	0.54	1.16	1.64
0.57	0.54	1.16	1.62

Bearings with contact angle $\alpha = 10^\circ$:

Single bearings and matched pairs "T" arrangement:

$$P_r = F_r \quad \text{for } F_a / F_r \leq e \quad [\text{kN}]$$

$$P_r = 0.46 F_r + Y F_a \quad \text{for } F_a / F_r > e \quad [\text{kN}]$$

F_a/iC_{or}	e	Y
0.014	0.29	1.88
0.029	0.32	1.71
0.057	0.36	1.52
0.086	0.38	1.41
0.11	0.40	1.34
0.17	0.44	1.23
0.29	0.49	1.10
0.43	0.54	1.01
0.57	0.54	1.00

i - number of bearings
 C_{or} - radial basic load rating of individual bearing from dimensional tables [kN]

Matched pairs "O" and "X" arrangement:

$$P_r = F_r + Y_1 \cdot F_a \quad \text{for } F_a / F_r \leq e \quad [\text{kN}]$$

$$P_r = 0.46 F_r + Y_2 \cdot F_a \quad \text{for } F_a / F_r > e \quad [\text{kN}]$$

F_a/C_{or}	e	Y_1	Y_2
0.014	0.29	2.18	3.06
0.029	0.32	1.94	2.78
0.057	0.36	1.76	2.47
0.086	0.38	1.63	2.29
0.11	0.40	1.55	2.18
0.17	0.44	1.42	2.00
0.29	0.49	1.27	1.79
0.43	0.54	1.17	1.64
0.54	0.54	1.16	1.63

If the shaft has two single row angular contact ball bearings, the radial load produces radial and axial load components. The axial load of one bearing depends on the load and contact angle of the other bearing. These additional inner forces must be taken into account when calculating the bearing loads. The following table shows relations for various bearing arrangements.

Bearing Arrangement	Force Conditions	Bearing Axial Load	
		Bearing A	Bearing B
	$\frac{F_{rA}}{Y_A} \leq \frac{F_{rB}}{Y_B}$ $K_a \geq 0$	$F_{aA} = F_{aB} + K_a$	$F_{aB} = e F_{rB}$
	$\frac{F_{rA}}{Y_A} > \frac{F_{rB}}{Y_B}$ $K_a \geq e (F_{rA} - F_{rB})$	$F_{aA} = F_{aB} + K_a$	$F_{aB} = e F_{rB}$
	$\frac{F_{rA}}{Y_A} > \frac{F_{rB}}{Y_B}$ $K_a < e (F_{rA} - F_{rB})^1$	$F_{aA} = e F_{rA}$	$F_{aB} = F_{aA} - K_a$
	$\frac{F_{rA}}{Y_A} \geq \frac{F_{rB}}{Y_B}$ $K_a \geq 0$	$F_{aA} = e F_{rA}$	$F_{aB} = F_{aA} + K_a$
	$\frac{F_{rA}}{Y_A} > \frac{F_{rB}}{Y_B}$ $K_a \geq e (F_{rB} - F_{rA})$	$F_{aA} = e F_{rA}$	$F_{aB} = F_{aA} + K_a$
	$\frac{F_{rA}}{Y_A} < \frac{F_{rB}}{Y_B}$ $K_a < e (F_{rB} - F_{rA})^1$	$F_{aA} = F_{aB} - K_a$	$F_{aB} = e F_{rB}$

¹⁾ Valid for $K_a = 0$

For bearings with contact angle $\alpha = 40^\circ$ (BE a B)

For bearings with contact angle $\alpha = 26^\circ$ (AA)

For other bearings e and Y according to tables - pages 46 to 47

$e = 1.14; Y = 0.57$

$e = 0.68; Y = 0.87$

Radial Equivalent Static Load

Bearings with contact angle $\alpha = 40^\circ$:

$$P_{or} = 0.5 F_r + 0.26 F_a \quad (P_{or} = F_r) \quad [\text{kN}]$$

Bearings with contact angle $\alpha = 26^\circ$ and $\alpha = 25^\circ$:

Single bearings and matched pairs "T" arrangement:

$$P_{or} = 0.5 F_r + 0.37 F_a \quad (P_{or} = F_r) \quad [\text{kN}]$$

Matched pairs "O" and "X" arrangements:

$$P_{or} = F_r + 0.74 F_a \quad [\text{kN}]$$

Bearings with contact angle $\alpha = 15^\circ$:

Single bearings and matched pairs "T" arrangement:

$$P_{or} = 0.5 F_r + 0.46 F_a \quad (P_{or} = F_r) \quad [\text{kN}]$$

Matched pairs "O" and "X" arrangements:

$$P_{or} = F_r + 0.92 F_a \quad [\text{kN}]$$

Bearings with contact angle $\alpha = 12^\circ$:

Single bearings and matched pairs “T” arrangement:

$$P_{or} = 0.5 F_r + 0.47 F_a \quad (P_{or} \geq F_r) \quad [\text{kN}]$$

Matched pairs “O” and “X” arrangements:

$$P_{or} = F_r + 0.94 F_a \quad [\text{kN}]$$

Bearings with contact angle $\alpha = 10^\circ$:

Single bearings and matched pairs “T” arrangement:

$$P_{or} = 0.6 F_r + 0.5 F_a \quad (P_{or} \geq F_r) \quad [\text{kN}]$$

Matched pairs, “O” and “X” arrangements:

$$P_{or} = F_r + 0.97 F_a \quad [\text{kN}]$$

Designation

Listed below are some common designations for single row angular contact bearings.

Single Row Angular Contact Ball Bearings		
Prefix	Description	Example of Designation
A	Internal construction with two ribs on the outer ring	A 7201AATA P5
B	Internal construction with two ribs on the inner ring	B 7018CATB P4
Suffix	Description	Example of Designation
A	Contact angle $\alpha = 25^\circ$	7203 A
AA	Contact angle $\alpha = 26^\circ$	7212 AA
B	Contact angle $\alpha = 40^\circ$	7214 B
C	Contact angle $\alpha = 15^\circ$	B7211 CATB P5
CA	Contact angle $\alpha = 12^\circ$	B7210 CATB P5
CB	Contact angle $\alpha = 10^\circ$	B7200 CBTB P4
MB	Machined brass cage guided on the inner ring	B7017AA MB
TA	Textite (fabric-reinforced phenolic resin) cage guided on the outer ring	A7201AA TA P5
TB	Textite (fabric-reinforced phenolic resin) cage guided on the inner ring	B7203CB TB P4
TNG	Polyamide cage reinforced with glass fiber, guided on the rolling elements	7304B TNG
P6	Higher tolerance class than normal	7204B P6
P5	Higher tolerance class than P6	B7014AATB P5
P4	Higher tolerance class than P5	B7206CBTB P4
O	Duplex mounting of bearings in a back-to-back configuration	B7024CATB P5 OL
X	Duplex mounting of bearings in a face-to-face configuration	B7210CBTB P4 XM
T	Duplex mounting of bearings in a tandem configuration	B7215CATB P5 T
OT	Triplex mounting of bearings O+T	B7018CATB P5 OTL
XT	Triplex mounting of bearings X+T	B7211CATB P4 XTM
TT	Triplex mounting of bearings T+T	B7205AATB P4 TT
L	With light preload	B7016AATB P5O L
M	With medium preload	B7206CBTB P4X M
S	With heavy preload	B7209CATB P4O S

Single Row Angular Contact Ball Bearings

d = 10 to 50 mm

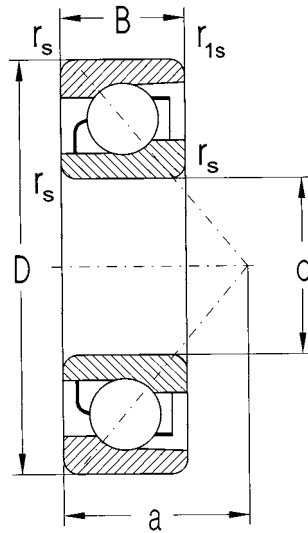

C

Dimension						Basic Load Rating			
d	D	B	r _s min	r _{1s} min	a	Dynamic C _r	Static C _{0r}	Dynamic C _r	Static C _{0r}
mm						kN	kN	lbs.	lbs.
10	30	9.0	0.60	0.30	13.0	6.940	3.290	1,560	740
12	32	10.0	0.60	0.30	14.0	7.500	3.760	1,686	845
15	35	11.0	0.60	0.30	12.0	8.410	4.380	1,891	985
	35	11.0	0.60	0.30	16.0	7.360	4.380	1,655	985
17	42	13.0	1.00	0.60	18.0	13.100	6.560	2,945	1,475
	40	12.0	0.60	0.30	13.0	10.400	6.190	2,338	1,392
	40	12.0	0.60	0.30	18.0	11.000	6.070	2,473	1,365
	47	14.0	1.00	0.60	15.0	14.100	7.940	3,170	1,785
	47	14.0	1.00	0.60	20.0	13.300	7.220	2,990	1,623
20	47	14.0	1.00	0.60	20.0	16.200	8.250	3,642	1,855
	47	14.0	1.00	0.60	15.0	14.400	7.790	3,237	1,751
	47	14.0	1.00	0.60	21.0	13.307	7.645	2,992	1,719
	52	15.0	1.10	0.60	23.0	17.400	9.620	3,912	2,163
25	52	15.0	1.10	0.60	23.0	18.800	10.400	4,226	2,338
	52	15.0	1.00	0.60	17.0	16.200	10.600	3,642	2,383
	62	17.0	1.10	0.60	27.0	24.280	14.700	5,440	3,305
30	62	16.0	1.00	0.60	27.0	20.700	13.600	4,654	3,057
	62	16.0	1.00	0.60	27.0	22.400	14.700	5,036	3,305
35	80	21.0	1.50	1.00	35.0	36.900	24.200	8,295	5,440
40	80	18.0	1.10	0.60	23.0	37.600	26.600	8,453	5,980
	80	18.0	1.10	0.60	34.0	36.900	24.600	8,295	5,530
	90	23.0	1.50	1.00	27.2	48.200	33.500	10,836	7,531
	90	23.0	1.50	1.00	39.0	44.700	30.400	10,049	6,834
45	85	19.0	1.10	0.60	25.5	39.800	29.300	8,947	6,587
	85	19.0	1.10	0.60	37.0	38.300	27.100	8,610	6,092
	100	25.0	1.50	1.00	43.0	58.200	39.800	13,084	8,947
50	90	20.0	1.10	0.60	27.0	41.400	32.200	9,307	7,239
	90	20.0	1.10	0.60	39.0	39.800	29.900	8,947	6,722

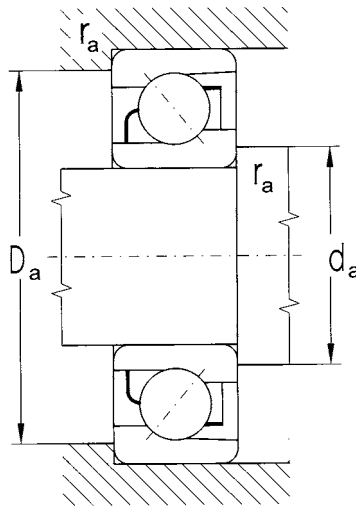

Limiting Speed for Lubrication with		Bearing Designation	Abutment and Fillet Dimensions				Weight kg
Grease	Oil		d	d _a min	D _a max	r _a max	
rpm			mm				
21,000	28,000	7200BETNG	10	14.5	25.5	0.6	0.0300
19,000	26,000	7201BETNG	12	16.5	27.5	0.6	0.0370
17,000	20,000	7202AA	15	19.0	31.0	0.6	0.0500
17,000	20,000	7202B		19.0	31.0	0.6	0.0500
14,000	17,000	7302BETNG	17	21.0	36.0	1.0	0.0800
15,000	18,000	7203AA		21.0	36.0	0.6	0.0700
17,000	20,000	7203BETNG		21.0	36.0	0.6	0.0700
12,600	15,000	7303AA		23.0	41.0	1.0	0.1200
12,600	15,000	7303B		23.0	41.0	1.0	0.1200
12,600	15,000	7303BETNG		23.0	41.0	1.0	0.1070
12,600	15,000	7204AA	20	25.0	42.0	1.0	0.1100
12,600	15,000	7204B		25.0	42.0	1.0	0.1100
12,600	15,000	7304B		26.0	45.0	1.0	0.1500
13,000	16,000	7304BETNG		26.0	45.0	1.0	0.1430
10,600	12,600	7205AA	25	30.0	47.0	1.0	0.1350
12,600	15,000	7205BETNG		30.0	47.0	1.0	0.1350
9,400	11,000	7305B		31.0	55.0	1.0	0.2400
9,400	11,000	7206B	30	36.0	56.0	1.0	0.2000
10,600	12,000	7206BETNG		35.0	56.0	1.0	0.1900
7,100	8,400	7307B	35	42.0	71.0	1.5	0.4800
7,100	8,400	7208AA	40	47.0	73.0	1.0	0.3700
7,900	9,400	7208BETNG		47.0	73.0	1.0	0.3700
6,300	7,500	7308AA		47.0	81.0	1.5	0.6600
7,100	8,400	7308BETNG		47.0	81.0	1.5	0.6600
6,300	7,500	7209AA		45	52.0	78.0	1.0
7,500	8,900	7209BETNG	52.0		78.0	1.0	0.4250
5,600	6,700	7309B	52.0		91.0	1.5	0.8800
6,000	7,100	7210AA	50		57.0	83.0	1.0
6,700	7,900	7210BETNG		57.0	83.0	1.0	0.4800

Single Row Angular Contact Ball Bearings

d = 55 to 75 mm

C

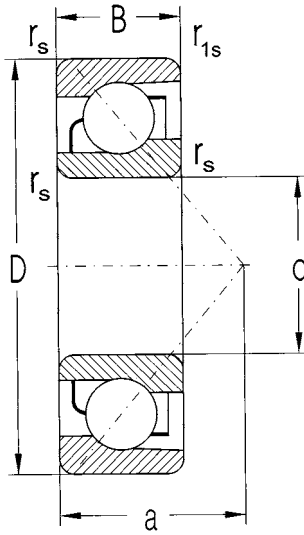

Dimension						Basic Load Rating			
d	D	B	r _s min	r _{1s} min	a	Dynamic C _r	Static C _{or}	Dynamic C _r	Static C _{or}
mm						kN	kN	lbs.	lbs.
55	100	21.0	1.50	1.00	29.5	52.628	40.460	11,488	9,127
	120	29.0	2.00	1.00	51.0	78.742	56.380	17,850	12,634
60	110	22.0	1.50	1.00	32.0	63.400	50.625	13,916	11,263
	120	23.0	1.50	1.00	34.0	70.800	59.600	15,917	13,399
65	140	33.0	2.10	1.10	41.0	110.000	84.100	24,729	18,907
	125	24.0	1.50	1.00	53.0	69.400	57.300	15,602	12,882
70	150	35.0	2.10	1.10	44.5	123.000	96.200	27,652	21,627
	130	25.0	1.50	1.00	56.0	71.000	61.900	15,962	13,916
75	160	37.0	2.10	1.10	68.0	127.615	96.415	28,101	22,054

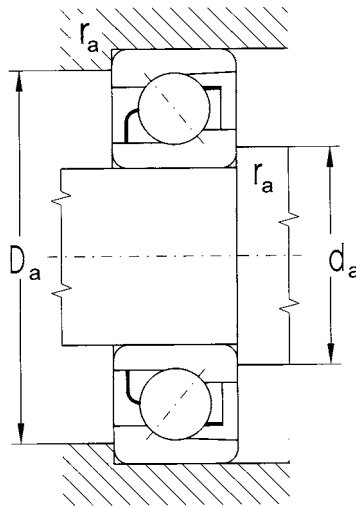

Limiting Speed for Lubrication with		Bearing Designation	Abutment and Fillet Dimensions				Weight
Grease	Oil		d	d _a min	D _a max	r _a max	
rpm			mm				kg
5.300	6.300	7211AA	55	62	91	1.5	0.6300
4.700	5.600	7311B		65	110	2.0	1.4500
5.000	6.000	7212AA	60	67	101	1.5	0.8000
4.500	5.300	7213AA	65	72	111	1.5	1.0000
4.000	4.700	7313AA		76	128	2.0	2.7100
4.200	5.000	7214B	70	77	116	1.5	1.1000
3.800	4.500	7314AA		81	138	2.0	3.1600
4.200	5.000	7215B	75	82	121	1.5	1.2100
3.300	4.000	7315B		86	148	2.0	3.8800

Single Row Angular Contact Ball Bearings for High Rotational Speed

d = 7 to 40 mm

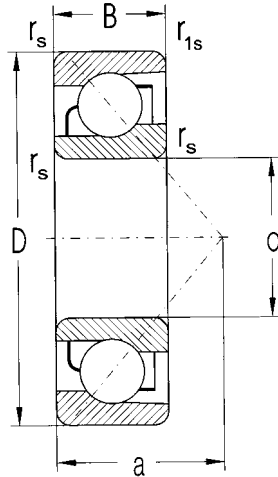

C

Dimension						Basic Load Rating			
d	D	B	r _s min	r _{1s} min	a	Dynamic C _r	Static C _{or}	Dynamic C _r	Static C _{or}
mm						kN	kN	lbs.	lbs.
7	22	7.0	0.30	0.15	5.0	2.220	0.900	499	202
9	26	8.0	0.60	0.30	5.5	3.650	1.640	821	369
10	30	9.0	0.60	0.30	7.0	4.530	3.280	1,018	737
	30	9.0	0.60	0.30	6.0	5.000	2.290	1,124	515
	30	9.0	0.60	0.30	6.5	6.670	2.900	1,499	652
12	32	10.0	0.60	0.30	7.0	5.480	2.655	1,232	597
	32	10.0	0.60	0.30	7.5	7.430	3.465	1,670	779
	32	10.0	0.60	0.30	10.5	7.045	3.210	1,584	722
15	35	11.0	0.60	0.30	7.5	6.480	3.450	1,457	776
	35	11.0	0.60	0.30	8.0	8.265	4.180	1,858	940
17	35	10.0	0.30	0.15	9.0	6.240	3.470	1,403	780
	35	10.0	0.30	0.15	8.0	4.550	4.250	1,023	955
	40	12.0	0.60	0.30	8.5	7.830	4.250	1,760	955
	40	12.0	0.60	0.30	9.0	10.206	5.290	2,294	1,189
20	42	12.0	0.60	0.30	10.0	9.830	5.450	2,210	1,225
	42	12.0	0.60	0.30	10.0	7.220	6.900	1,623	1,551
	47	14.0	1.00	0.60	10.0	9.600	5.540	2,158	1,245
	47	14.0	1.00	0.60	10.5	13.670	7.322	3,073	1,646
	47	14.0	1.00	0.60	15.0	13.000	6.990	2,923	1,571
25	47	12.0	0.60	0.30	11.0	11.080	6.870	2,491	1,544
	47	12.0	0.60	0.30	11.0	7.940	7.850	1,785	1,765
	52	15.0	1.00	0.60	11.0	13.125	7.960	2,951	1,789
	52	15.0	1.00	0.60	11.5	14.815	8.630	3,331	1,940
	52	15.0	1.00	0.60	17.0	13.960	8.155	3,138	1,833
30	55	13.0	1.00	0.60	12.0	14.400	9.550	3,237	2,147
	55	13.0	1.00	0.60	12.2	10.220	11.090	2,298	2,493
	62	16.0	1.00	0.60	12.0	16.810	10.720	3,779	2,410
	62	16.0	1.00	0.60	13.0	20.570	12.420	4,624	2,792
	62	16.0	1.00	0.60	19.0	19.420	11.580	4,366	2,603
35	62	14.0	1.00	0.60	14.0	18.290	12.700	4,112	2,855
	62	14.0	1.00	0.60	13.0	12.800	14.730	2,878	3,311
	62	14.0	1.00	0.60	18.5	17.300	12.050	3,889	2,709
	72	17.0	1.10	0.60	13.0	21.015	14.345	4,724	3,225
	72	17.0	1.10	0.60	14.0	28.935	18.600	6,505	4,181
	72	17.0	1.10	0.60	15.0	30.660	20.295	6,893	4,562
	72	17.0	1.10	0.60	10.0	27.200	17.400	6,115	3,912
40	68	15.0	1.00	0.60	20.5	18.560	14.135	4,172	3,178
	80	18.0	1.10	0.60	14.0	24.500	17.300	5,508	3,889
	80	18.0	1.10	0.60	15.5	36.730	23.775	8,257	5,345

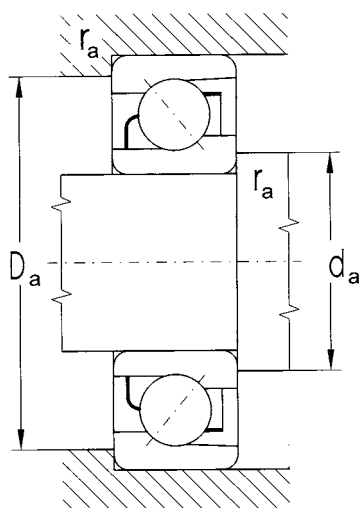

C

Limiting Speed for Lubrication with		Bearing Designation	Abutment and Fillet Dimensions				Weight
Grease	Oil		d	d _a min	D _a max	r _a max	
rpm			mm				
94,000	140,000	A727CBTA	7	9.2	19.5	0.3	0.0134
71,000	106,000	A729CBTA	9	12.0	22.5	0.6	0.0197
45,000	65,000	B7200CTA	10	14.0	26.0	0.6	0.0280
60,000	89,000	B7200CTB		14.0	26.0	0.6	0.0270
42,000	63,000	B7200CATB		14.0	26.0	0.6	0.0280
56,000	84,000	B7201CTB	12	16.0	28.0	0.6	0.0350
38,000	56,000	B7201CATB		16.0	28.0	0.6	0.0360
33,000	50,000	AC7201ATA		16.0	28.0	0.6	0.3060
50,000	75,000	B7202CTB	15	19.0	31.0	0.6	0.0420
33,000	50,000	B7202CATB		19.0	31.0	0.6	0.0420
30,000	45,000	A7003CTA		17	19.0	33.0	0.3
44,000	67,500	B7003CTA	17	19.0	33.0	0.3	0.0390
45,000	67,000	B7203CTB		21.0	36.0	0.6	0.0600
28,000	42,000	B7203CATB		21.0	36.0	0.6	0.0610
28,000	42,000	A7004CTA	20	24.0	38.0	0.6	0.0680
39,000	57,000	B7004CTA		24.0	38.0	0.6	0.0660
40,000	60,000	B7204CTB		25.0	42.0	1.0	0.0980
25,000	38,000	B7204CATB	20	25.0	42.0	1.0	0.1000
22,000	33,000	B7204AATB		25.0	42.0	1.0	0.1020
25,000	38,000	A7005CTA		25	28.0	43.0	0.6
33,000	47,000	B7005CTA	25	28.0	43.0	0.6	0.0800
33,000	50,000	B7205CTB		30.0	47.0	1.0	0.1190
22,000	33,000	B7205CATB		30.0	47.0	1.0	0.1220
20,000	30,000	B7205AATB	30	30.0	47.0	1.0	0.1240
22,000	30,000	A7006CTA		34.0	50.0	1.0	0.1160
26,000	40,000	B7006CTA		34.0	50.0	1.0	0.1150
28,000	42,000	B7206CTB	30	35.0	57.0	1.0	0.1840
20,000	30,000	B7206CATB		35.0	57.0	1.0	0.1890
17,000	25,000	B7206AATB		35.0	57.0	1.0	0.1920
17,000	25,000	A7007CTA	35	39.5	57.0	1.0	0.1550
22,000	36,000	B7007CTA		39.5	57.0	1.0	0.1550
9,400	11,000	B7007AATB		39.5	57.0	1.0	0.1480
25,000	38,000	B7207CTB	35	42.0	65.0	1.0	0.2680
16,000	24,000	B7207CATB		42.0	65.0	1.0	0.2750
16,000	24,000	B7207CAMB		42.0	65.0	1.0	0.3230
13,000	20,000	B7207AATB	40	42.0	65.0	1.0	0.2810
8,400	10,000	B7008AATB		47.0	61.0	1.0	0.1850
22,000	33,000	B7208CTB		47.0	73.0	1.0	0.3370
13,000	20,000	B7208CATB	47.0	73.0	1.0	0.3470	

Single Row Angular Contact Ball Bearings for High Rotational Speed

d = 45 to 130 mm

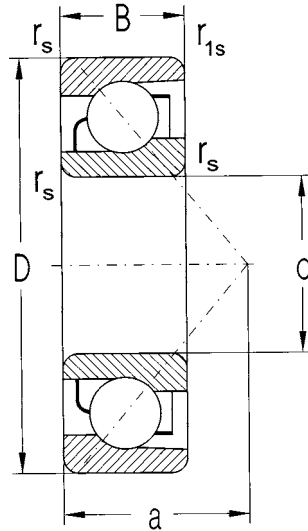

C

Dimension						Basic Load Rating			
d	D	B	r_s min	r_{1s} min	a	Dynamic C_r	Static C_{Or}	Dynamic C_r	Static C_{Or}
mm						kN	kN	lbs.	lbs.
45	68	12.0	0.60	0.30	13.6	9.060	10.900	2,037	2,450
	75	16.0	1.00	0.60	16.0	23.410	18.140	5,263	4,078
	75	16.0	1.00	0.60	16.0	15.500	19.380	3,485	4,357
	85	19.0	1.10	0.60	15.0	28.295	20.310	6,361	4,566
	85	19.0	1.10	0.60	16.5	36.855	24.645	8,285	5,540
	100	25.0	1.50	1.00	28.0	60.330	38.775	13,563	8,717
50	80	16.0	1.00	0.60	20.0	22.660	18.520	5,094	4,163
	90	20.0	1.10	0.60	16.0	32.330	23.560	7,268	5,296
	90	20.0	1.10	0.60	17.5	38.990	27.260	8,765	6,128
	90	20.0	1.10	0.60	26.0	36.560	25.920	8,219	5,827
55	90	18.0	1.10	0.60	26.5	30.990	25.380	6,967	5,706
	100	21.0	1.50	1.00	17.0	38.460	29.120	8,646	6,546
	100	21.0	1.50	1.00	18.5	48.200	34.500	10,836	7,756
60	110	22.0	1.50	1.00	18.0	42.980	33.800	9,662	7,599
	110	22.0	1.50	1.00	20.0	58.260	42.600	13,097	9,577
	110	22.0	1.50	1.00	32.0	54.820	39.960	12,324	8,983
65	120	23.0	1.50	1.00	21.5	70.500	54.780	15,849	12,315
70	110	20.0	1.10	0.60	32.0	41.153	36.460	9,252	8,197
	125	24.0	1.50	1.00	20.5	58.560	47.660	13,165	10,714
	125	24.0	1.50	1.00	22.5	76.650	60.135	17,232	13,519
75	130	25.0	1.50	1.00	23.5	76.530	61.390	17,205	13,801
	130	25.0	1.50	1.00	37.5	71.525	58.325	16,079	13,112
	130	25.0	1.50	1.00	37.5	74.900	62.490	16,838	14,048
80	125	22.0	1.10	0.60	22.0	55.360	50.013	12,445	11,243
	125	22.0	1.10	0.60	36.0	53.440	49.440	12,014	11,115
	140	26.0	2.00	1.00	24.5	89.500	73.050	20,120	16,422
	140	26.0	2.00	1.00	40.0	84.070	68.040	18,900	15,296
85	130	22.0	1.10	0.60	37.0	54.440	52.690	12,239	11,845
	130	22.0	1.10	0.60	37.0	56.240	55.330	12,643	12,439
	150	28.0	2.00	1.00	26.5	100.520	86.080	22,598	19,352
	150	28.0	2.00	1.00	42.5	94.260	80.670	21,190	18,135
90	140	24.0	1.50	1.00	24.0	67.630	62.470	15,204	14,044
	140	24.0	1.50	1.00	26.8	65.220	62.600	14,662	14,073
	140	24.0	1.50	1.00	40.0	65.290	61.755	14,678	13,883
100	180	34.0	2.10	1.10	51.0	141.100	120.960	31,721	27,193
120	180	28.0	2.00	1.00	35.0	97.460	102.120	21,910	22,957
	180	28.0	2.00	1.00	30.0	101.100	103.660	22,728	23,304
	180	28.0	2.00	1.00	50.5	96.100	101.280	21,604	22,769
130	165	11.0	1.00	0.50	41.5	13.475	19.100	3,029	4,294

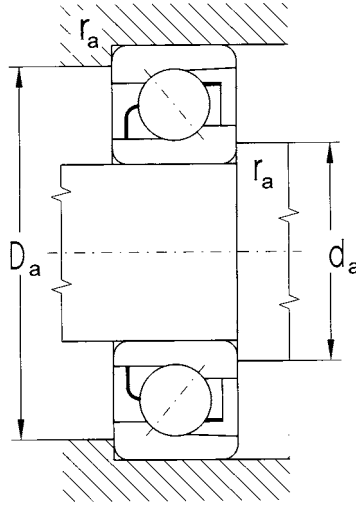

C

Limiting Speed for Lubrication with		Bearing Designation	Abutment and Fillet Dimensions				Weight
Grease	Oil		d	d _a min	D _a max	r _a max	
rpm			mm				kg
19,000	32,000	B71909CTA	45	50	63	0.6	0.1290
13,000	20,000	A7009CTA		49	70	1.0	0.2420
18,000	30,000	B7009CTA		49	70	1.0	0.2450
20,000	30,000	B7209CBTB		52	78	1.0	0.3810
12,600	19,000	B7209CATB		52	78	1.0	0.3910
5,600	6,700	B7309CATB		54	91	1.5	0.7710
9,500	11,000	B7010AATB	50	57	73	1.0	0.4310
18,000	27,000	B7210CBTB		57	83	1.0	0.4430
12,000	18,000	B7210CATB		57	83	1.0	0.4430
10,600	16,000	B7210AATB		57	83	1.0	0.4470
6,300	7,500	B7011AATB	55	62	83	1.0	0.3950
17,000	25,000	B7211CBTB		62	91	1.5	0.5670
11,000	17,000	B7211CATB		62	91	1.5	0.5820
15,000	22,000	B7212CBTB	60	67	101	1.5	0.7350
10,000	15,000	B7212CATB		67	101	1.5	0.7540
8,900	13,000	B7212AATB		67	101	1.5	0.7590
8,900	13,000	B7213CATB	65	72	111	1.5	0.9940
7,900	12,000	B7014AATB	70	75	103	1.0	0.5970
12,600	19,000	B7214CBTB		77	116	1.5	1.0400
7,900	12,000	B7214CATB		77	116	1.5	1.0700
7,500	11,000	B7215CATB	75	82	121	1.5	1.1600
6,700	10,000	B7215AATB		82	121	1.5	1.2600
6,700	10,000	B7215AAMB		82	121	1.5	1.3900
7,500	11,000	B7016CATB	80	85	118	1.0	0.8410
6,700	10,000	B7016AATB		85	118	1.0	0.8480
6,700	10,000	B7216CATB		90	130	2.0	1.4100
6,300	9,400	B7216AATB		90	130	2.0	1.4200
6,300	9,400	B7017AATA	85	90	123	1.0	0.9120
6,300	9,400	B7017AAMB		90	123	1.0	1.0600
6,300	9,400	B7217CATB		95	140	2.0	1.8000
6,000	8,900	B7217AATB		95	140	2.0	1.8200
6,300	9,400	B7018CATB	90	96	132	1.5	1.1500
4,000	4,800	B7018ATA		96	132	1.5	0.5970
4,000	4,700	B7018AATB		98	130	1.5	1.1600
5,300	7,900	B7220AATB	100	112	168	2.0	3.3200
3,000	3,600	B7024ATA	120	128	171	2.0	0.155
5,000	7,500	B7024CATB		128	171	2.0	2.1000
3,000	3,500	B7024AATB		132	168	2.0	2.0900
3,200	3,800	B70826AAMB	130	138	158	2.0	0.6350

Single Row Angular Contact Ball Bearings for Special Applications

C

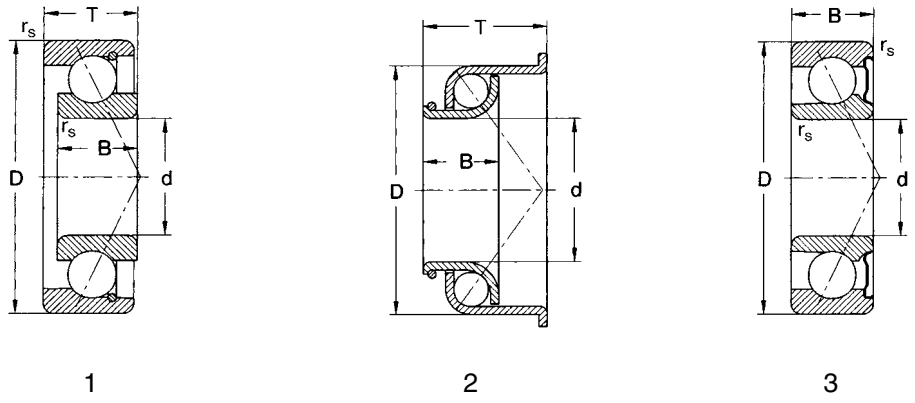

Dimension						Basic Load Rating			
d	D	B	B ₁	T	r _s min.	Dynamic C _r	Static C _{or}	Dynamic C _r	Static C _{or}
mm						kN	kN	lbs.	lbs.
12	32.00	6.5	6.0	-	0.4	8.40	3.95	1,888.395	887.995
	32.00	8.0	6.0	-	0.4	8.40	3.95	1,888.395	887.995
	32.00	9.0	-	10.0	0.6	8.80	4.70	1,978.319	1,056.602
13	30.00	7.0	-	-	0.3	4.47	0.98	1,004.896	220.313
15	35.00	8.0	-	-	0.3	5.84	1.30	1,312.884	292.252
16.155	27.60	8.0	-	-	0.3	1.88	0.36	422.641	79.807
17	35.00	7.8	-	9.0	-	8.25	5.21	1,854.674	1,171.255
18	35.00	7.8	-	9.0	0.6	8.25	5.21	1,854.674	1,171.255
22.2	36.85	11.4	-	17.9	-	5.11	6.31	1,148.774	1,418.544
	36.85	11.4	-	16.5	-	5.11	6.31	1,148.774	1,418.544
25	45.00	10.0	-	12.0	0.6	9.10	7.30	2,045.761	1,641.105
	47.00	12.0	-	-	0.6	14.20	9.25	3,192.287	2,079.483
	52.00	15.0	-	-	1.0	19.70	12.00	4,428.736	2,697.707
26.07	45.00	10.0	-	12.0	0.6	9.10	7.30	2,045.761	1,641.105

¹⁾ Bearings are intended for oscillating motion or low frequency of rotation.

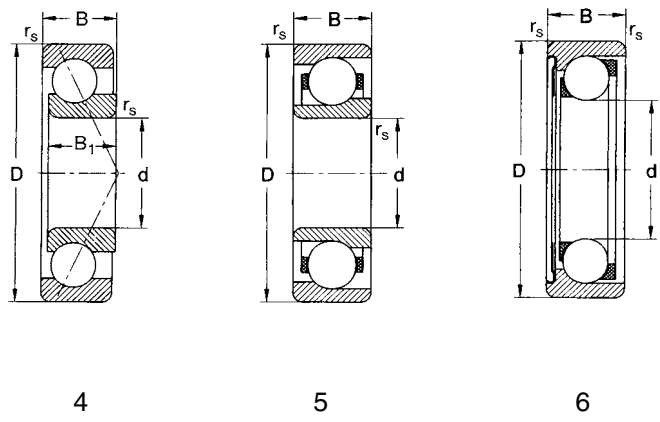

Limiting Speed for Lubrication With		Bearing Designation	Weight kg	Seals	Cage	Figure
Grease	Oil					
rpm						
1)	-	PLC 03-81	0.025	-	-	4
1)	-	PLC 03-81-1	0.027	-	-	4
1)	1)	PLC 03-73	0.035	-	-	1
24,000	28,000	PLC 02-39	0.020	-	TNG	5
21,000	25,000	PLC 03-88	0.031	-	TNG	5
16,000	-	PLC 02-32	0.0128	RS	TNGH	6
1)	1)	PLC 03-29-1	0.033	-	-	1
1)	1)	PLC 03-29-2	0.031	-	-	1
1)	-	PLC 03-19	0.036	-	-	2
1)	-	PLC 03-33	0.034	-	-	2
1)	1)	PLC 23-8-2	0.063	-	-	1
1)	-	PLC 03-217	0.080	-	-	3
1)	-	PLC 04-214	0.120	-	-	3
1)	1)	PLC 23-8-1	0.060	-	-	1

Double Row Angular Contact Ball Bearings



ZVL-ZKL double row angular contact ball bearings correspond, in principle, to two single row angular contact ball bearings in the back-to-back arrangement; however, there is a narrower profile for the same bearing size. The connecting line of the raceway-to-ball contact points intersects the bearing axis outside the bearing at a contact angle of $\alpha = 32^\circ$. These bearings are produced with a filling slot on one side to achieve maximum load ratings. If axial forces act predominately in one direction, the bearing must be mounted so that these forces do not push against its filling slot.

Cage

Double row angular contact ball bearings are produced with pressed steel cages.

Boundary Dimensions

Boundary dimensions comply with the standard ISO 15.

Tolerance

These bearings are produced within ABEC 1 or P0 tolerance class. More demanding tolerance classes may be produced upon request. The basic bearing dimensions comply with standards ISO 199 and ISO 492.

Radial/Axial Clearance

Double row angular contact bearings are commonly produced with C0 or C3 fits. Other clearance fits may be available upon request. These clearance values are listed in the chart below.

Bore Diameter		Axial Clearance of Double Row Angular Contact Ball Bearings							
d		C2		normal		C3		C4	
over	to	min	max	min	max	min	max	min	max
mm		µm							
6	10	1	11	5	21	12	28	25	45
10	18	1	12	6	23	13	31	27	47
18	24	2	14	7	25	16	34	28	48
24	30	2	15	8	27	18	37	30	50
30	40	2	16	9	29	21	40	33	54
40	50	2	19	11	33	23	44	36	58
50	65	3	22	13	36	26	48	40	63
65	80	3	24	15	40	30	54	46	71

Misalignment

Double row angular contact bearings create a very rigid arrangement and do not accept misalignment.

Radial Equivalent Dynamic Load

$$P_r = F_r + 0.73 F_a \quad \text{for } F_a / F_r \leq 0.86$$

$$P_r = 0.62 F_r + 1.17 F_a \quad \text{for } F_a / F_r > 0.86$$

Radial Equivalent Static Load

$$P_{or} = F_r + 0.63 F_a$$

Designation

Listed below are some of the common designations for double row angular contact ball bearings.

Double Row Angular Contact Ball Bearings		
Suffix	Description	Example of Designation
N	Snap ring groove in the outer ring, opposite side of filling slot	3205 N
NC	Snap ring groove in the outer ring, same side as the filling slot	3210 NC
NS	Snap ring groove in the center of the outer ring	3203 NS
P6	Higher tolerance class than normal	3210 P6
P5	Higher tolerance class than P6	3305 P5
P4	Higher tolerance class than P5	3203 P4
C2	Radial clearance less than normal	3200 C2
C3	Radial clearance greater than normal	3208 C3
C4	Radial clearance greater than C3	3313 C4

D

Double Row Angular Contact Ball Bearings

d = 10 to 75 mm

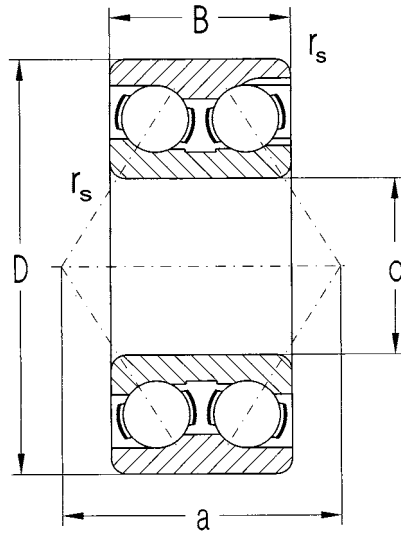

Dimension					Basic Load Rating			
d	D	B	r _s min	a	Dynamic C _r	Static C _{0r}	Dynamic C _r	Static C _{0r}
mm					kN	kN	lbs.	lbs.
10	30	14.0	0.60	20	8.41	5.84	1,891	1,313
	30	14.3	0.60	20	8.41	5.84	1,891	1,313
12	32	15.9	0.60	22	10.00	7.08	2,248	1,592
15	35	15.9	0.60	23	9.44	7.50	2,122	1,686
	42	19.0	1.00	27	15.80	11.90	3,552	2,675
17	40	17.5	0.60	27	13.10	10.60	2,945	2,383
	47	22.2	1.00	31	21.50	16.20	4,833	3,642
20	47	20.6	1.00	31	18.10	15.00	4,069	3,372
	52	22.2	1.10	34	21.50	18.50	4,833	4,159
25	52	20.6	1.00	35	19.60	18.10	4,406	4,069
	62	25.4	1.10	40	29.90	26.60	6,722	5,980
30	62	23.8	1.00	41	28.20	27.10	6,340	6,092
	72	30.2	1.10	47	39.80	36.20	8,947	8,138
35	72	27.0	1.10	47	38.30	37.60	8,610	8,453
	80	34.9	1.50	54	51.10	47.30	11,488	10,634
40	80	30.2	1.10	52	43.80	43.80	9,847	9,847
	90	36.5	1.50	58	54.00	59.60	12,140	13,399
45	85	30.2	1.10	56	47.30	51.10	10,634	11,488
	100	39.7	1.50	64	75.00	73.60	16,861	16,546
50	90	30.2	1.10	59	54.10	58.40	12,162	13,129
	110	44.4	2.00	73	90.90	96.20	20,435	21,627
55	100	33.3	1.50	64	60.70	66.80	13,646	15,017
	120	49.2	2.00	80	100.00	108.00	22,481	24,279
60	110	36.5	1.50	71	75.00	85.80	16,861	19,289
	130	54.0	2.10	86	117.00	128.00	26,303	28,776
65	120	38.1	1.50	76	82.50	94.40	18,547	21,222
	140	58.7	2.10	94	133.00	147.00	29,900	33,047
70	125	39.7	1.50	81	79.40	98.10	17,850	22,054
75	130	41.5	1.50	84	87.40	110.00	19,648	24,729

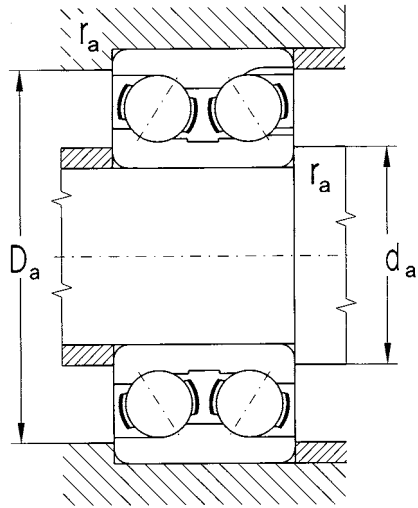

Limiting Speed for Lubrication with		Bearing Designation	Abutment and Fillet Dimensions				Weight
Grease	Oil		d	d_a min	D_a max	r_a max	
rpm			mm				kg
16,000	19,000	3200X	10	14	25	0.6	0.050
16,000	19,000	3200	10	14	25	0.6	0.050
14,000	17,000	3201	12	16	27	0.6	0.060
13,000	16,000	3202	15	19	30	0.6	0.070
10,600	12,600	3302	15	21	36	1.0	0.130
11,000	13,000	3203	17	21	35	0.6	0.100
9,400	11,000	3303	17	23	41	1.0	0.190
9,400	11,000	3204	20	25	42	1.0	0.170
8,400	10,000	3304	20	27	45	1.0	0.230
8,400	10,000	3205	25	30	46	1.0	0.190
7,100	8,400	3305	25	32	55	1.0	0.370
7,100	8,400	3206	30	35	56	1.0	0.310
6,000	7,100	3306	30	37	65	1.0	0.580
6,000	7,100	3207	35	41	65	1.0	0.480
5,300	6,300	3307	35	44	71	1.5	0.780
5,300	6,300	3208	40	46	73	1.0	0.650
4,700	5,600	3308	40	49	81	1.5	1.050
5,000	6,000	3209	45	51	78	1.0	0.700
4,200	5,000	3309	45	54	91	1.5	1.410
4,500	5,300	3210	50	56	83	1.0	0.740
3,800	4,500	3310	50	60	100	2.0	1.900
4,200	5,000	3211	55	62	91	1.5	1.050
3,300	4,000	3311	55	65	110	2.0	2.480
3,800	4,500	3212	60	67	101	1.5	1.360
3,200	3,800	3312	60	72	118	2.0	3.170
3,500	4,200	3213	65	72	111	1.5	1.760
3,000	3,500	3313	65	77	128	2.0	4.010
3,200	3,800	3214	70	77	116	1.5	1.930
3,200	3,800	3215	75	82	121	1.5	2.080

Double Row Angular Contact Ball Bearings for Special Applications

D

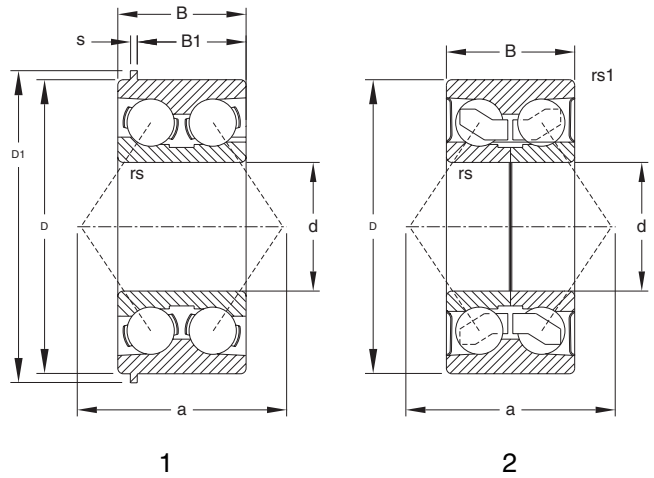

Dimension									Basic Load Rating			
d	D	B	D ₁	B ₁	s	r _s min	r _{1s} min	a	Dynamic C _r	Static C _{or}	Dynamic C _r	Static C _{or}
mm									kN	kN	lbs.	lbs.
25	65.5	25.4	74.0	16.5	4.4	1.1	-	40.0	30.4	26.6	6,834	5,980
30	60.0	37.0	-	-	-	2.5	0.5	50.5	36.9	30.4	8,295	6,834
35	68.0	37.0	-	-	-	2.5	0.3	50.5	39.8	38.3	8,947	8,610
37	72.0	37.0	-	-	-	2.5	0.5	57.0	43.8	39.8	9,847	8,947

Limiting Speed for Lubrication with		Bearing Designation	Weight	Figure
Grease	Oil			
rpm			kg	
7,100	8,400	PLC 15-2	0.466	1
7,000	-	PLC 14-25	0.455	2
6,500	-	PLC 15-12	0.534	2
5,000	-	PLC 15-22	0.550	2

Double Row Self-Aligning Ball Bearings



Double row self-aligning ball bearings are designed with two rows of balls and a spherical outer ring raceway. This design allows the inner ring to have a certain amount of misalignment with respect to the outer ring and will have no adverse effect on the bearing. These bearings are produced with cylindrical and tapered bores and are non-separable. These bearings are recommended for applications with small axial loads.

E Cage

Double row self-aligning ball bearings can be produced with several different types of cages. ZVL-ZKL produces a pressed steel, pressed brass, machined brass, and polyamide cage (TNGN) for these bearings.

Boundary Dimensions

Boundary dimensions comply with the standard ISO 15.

Tolerance

All double row self-aligning ball bearings are produced in accordance to ABEC 1 or P0 tolerance class. Standard ISO 199 and ISO 492 specify these tolerances.

Radial Clearance

All double row self-aligning ball bearings are offered in a range of radial clearances. The two normal radial clearances are C0 and C3. Other clearances may be produced upon request. All radial clearance values comply with standard ISO 5753 and are listed in the chart below.

Radial Clearance of Double Row Self-Aligning Ball Bearing																					
Bore Diameter		Cylindrical Bore Radial Clearance										Tapered Bore Radial Clearance									
d		C2		normal		C3		C4		C5		C2		normal		C3		C4		C5	
over	to	min	max	min	max	min	max	min	max	min	max	min	max	min	max	min	max	min	max	min	max
mm		µm										µm									
2.5	6	1	8	5	15	10	20	15	25	21	33	-	-	-	-	-	-	-	-	-	-
6	10	2	9	6	17	12	25	19	33	27	42	-	-	-	-	-	-	-	-	-	-
10	14	2	10	6	19	13	26	21	35	30	48	-	-	-	-	-	-	-	-	-	-
14	18	3	12	8	21	15	28	23	37	32	50	-	-	-	-	-	-	-	-	-	-
18	24	4	14	10	23	18	30	25	39	34	52	7	17	13	26	20	33	28	42	37	55
24	30	5	16	11	24	19	35	29	46	40	58	9	20	15	28	23	39	33	50	44	62
30	40	6	18	13	29	23	40	34	53	46	66	12	24	19	35	29	46	40	59	52	72
40	50	6	19	14	31	25	44	37	57	50	71	14	27	22	39	33	52	45	65	58	79
50	65	7	21	16	36	30	50	45	69	62	88	18	32	27	47	41	61	56	80	73	99
65	80	8	24	18	40	35	60	54	83	76	108	23	39	35	57	50	75	69	98	91	123
80	100	9	27	22	48	42	70	64	96	89	124	29	47	42	68	62	90	84	116	109	144
100	120	10	31	25	56	50	83	75	114	105	145	35	56	50	81	75	108	100	139	130	170
120	140	10	38	30	68	60	100	90	135	125	175	-	-	-	-	-	-	-	-	-	-
140	160	15	44	35	80	70	120	110	161	150	210	-	-	-	-	-	-	-	-	-	-

Tapered Bore

Bearings with a tapered bore have a taper of 1:12. These bearings are mounted onto shafts by use of adapter sleeves. Corresponding adapter sleeves are noted with each part number.

Misalignment

Values of permissible bearing misalignment are shown in the following table:

Bearing Type	Permissible Misalignment
d<10mm 126, 13, 23	3°
12, 22	2°30'

Radial Equivalent Dynamic Load

$$P_r = F_r + Y_1 F_a \quad \text{for } F_a / F_r \leq e \quad [\text{kN}]$$

$$P_r = 0.65 F_r + Y_2 F_a \quad \text{for } F_a / F_r > e \quad [\text{kN}]$$

Factor values e , Y_1 and Y_2 for individual bearings are shown in dimension tables.

Radial Equivalent Static Load

$$P_{or} = F_r + Y_0 F_a \quad [\text{kN}]$$

Factor values Y_0 for individual bearings are shown in dimension tables.

Designation

Listed below are some common designations for our double row self-aligning ball bearings:

Double Row Self-Aligning Ball Bearings		
Suffix	Description	Example of Designation
K	Tapered bearing bore at 1:12 ratio	1212 K
F	Machined steel cage guided on the rolling elements	1230 F
TNGN	Polyamide cage reinforced with glass fiber, guided on the rolling elements	2305 TNGN
P6	Higher tolerance class than normal	2206 P6
C2	Radial clearance less than normal	1201 C2
C3	Radial clearance greater than normal	1317 C3
C4	Radial clearance greater than C3	2322 C4

Double Row Self-Aligning Ball Bearings

d = 6 to 60 mm

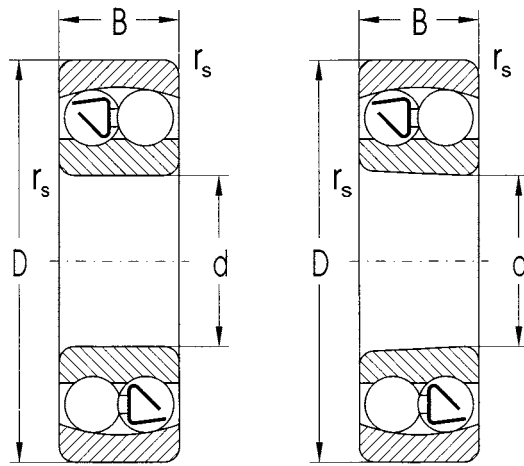

K

Dimension				Basic Load Rating				Limiting Speed for Lubrication with	
d	D	B	rs	Dynamic Cr	Static Cor	Dynamic Cr	Static Cor	Grease	Oil
mm				kN	kN	lbs.	lbs.	rpm	
6	19	6.0	0.30	1.930	0.520	434	117	27,000	32,000
10	30	14.0	0.60	5.600	1.700	1,259	382	25,000	30,000
12	32	10.0	0.60	4.300	1.460	967	328	24,000	28,000
15	35	11.0	0.60	5.700	2.000	1,281	450	21,000	25,000
	35	14.0	0.60	5.850	2.160	1,315	486	21,000	25,000
17	40	12.0	0.60	7.930	2.030	1,783	456	17,000	20,000
20	47	14.0	1.00	9.950	2.660	2,237	598	14,000	17,000
25	52	15.0	1.00	12.100	3.350	2,720	753	12,600	15,000
	52	18.0	1.00	12.400	3.480	2,788	782	12,600	15,000
	62	24.0	1.10	24.200	6.560	5,440	1,475	10,000	12,000
30	62	16.0	1.00	15.600	4.730	3,507	1,063	11,000	13,000
	62	19.0	1.00	15.300	4.550	3,440	1,023	11,000	13,000
	72	20.0	1.10	21.200	6.310	4,766	1,419	9,400	11,000
	72	27.0	1.10	31.200	8.740	7,014	1,965	8,400	10,000
35	72	17.0	1.10	15.900	5.110	3,574	1,149	9,400	11,000
	72	23.0	1.10	21.600	6.680	4,856	1,502	9,400	11,000
40	80	18.0	1.10	19.000	6.560	4,271	1,475	7,900	9,400
	90	23.0	1.50	29.600	9.810	6,654	2,205	7,100	8,400
	90	33.0	1.50	44.900	13.300	10,094	2,990	6,700	7,900
45	85	19.0	1.10	21.600	7.360	4,856	1,655	7,500	8,900
	85	23.0	1.10	23.400	8.100	5,261	1,821	7,500	8,900
	100	25.0	1.50	37.700	12.800	8,475	2,878	6,300	7,500
	100	36.0	1.50	54.000	16.500	12,140	3,709	6,000	7,100
50	90	20.0	1.10	22.900	8.100	5,148	1,821	7,100	8,400
	90	23.0	1.10	23.400	8.410	5,261	1,891	7,100	8,400
	110	27.0	2.00	43.600	14.100	9,802	3,170	5,600	6,700
55	100	21.0	1.50	26.500	10.000	5,957	2,248	6,300	7,500
	100	25.0	1.50	26.500	10.000	5,957	2,248	6,300	7,500
60	110	22.0	1.50	30.200	11.700	6,789	2,630	5,600	6,700
	110	28.0	1.50	33.800	12.600	7,599	2,833	5,600	6,700
	130	31.0	2.00	57.200	20.700	12,859	4,654	4,700	5,600

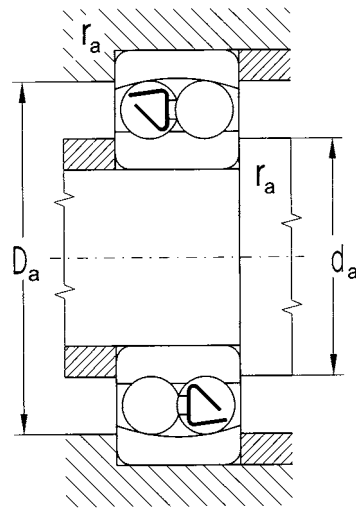

Bearing Designation		Abutment and Fillet Dimensions				Weight		Corresponding Adapter Sleeve	Factors			
with Cylindrical Bore	with Tapered Bore	d	d_a min	D_a max	r_a max		K		e	Y_1	Y_2	Y_0
		mm				kg						
126		6	8.2	17	0.3	0.0090	-	-	0.340	1.900	2.900	2.000
2200		10	14	26	0.6	0.0470	-	-	0.650	1.000	1.500	1.000
1201		12	16	18	0.6	0.0400	-	-	0.340	1.900	2.900	2.000
1202		15	19	31	0.6	0.0490	-	-	0.330	1.900	2.900	2.000
2202			19	31	0.6	0.0600	-	-	0.490	1.300	2.000	1.300
1203	1203K	17	21	36	0.6	0.0730	0.7100	H203	0.310	2.100	3.200	2.200
1204	1204K	20	25	42	1.0	0.1200	0.1180	H204	0.270	2.300	3.600	2.400
1205	1205K	25	30	47	1.0	0.1410	0.1380	H205	0.270	2.300	3.600	2.400
2205	2205K		30	47	1.0	0.1630	0.1580	H305	0.430	1.500	2.300	1.500
2305TNGN	2205KTNGN		31	55	1.0	0.3350	0.3270	H2305	0.470	1.300	2.100	1.400
1206	1206K	30	35	57	1.0	0.2200	0.2160	H206	0.250	2.600	4.000	2.700
2206	2206K		35	57	1.0	0.2600	0.2540	H306	0.400	1.600	2.500	1.700
1306	1306K		36	65	1.0	0.3870	0.3810	H306	0.260	2.500	3.800	2.600
2306	2306K		36	65	1.0	0.5000	0.4890	H2306	0.440	1.400	2.200	1.500
1207	1207K	35	42	65	1.0	0.3230	0.3170	H207	0.230	2.700	4.200	2.900
2207	2207K		42	65	1.0	0.4030	0.3960	H307	0.370	1.700	2.600	1.800
1208	1208K	40	47	73	1.0	0.4170	0.4110	H208	0.220	2.900	4.400	3.000
1308	1308K		47	81	1.5	0.7150	0.7040	H308	0.240	2.600	4.100	2.700
2308	2308K		47	81	1.5	0.9250	0.9030	H2308	0.430	1.500	2.300	1.500
1209	1209K	45	52	78	1.0	0.4650	0.4590	H209	0.210	3.000	4.600	3.100
2209	2209K		52	78	1.0	0.5450	0.5330	H309	0.310	2.100	3.200	2.200
1309	1309K		52	91	1.5	0.9570	0.9420	H309	0.250	2.500	3.900	2.700
2309	2309K		52	91	1.5	1.2300	1.2000	H2309	0.420	1.500	2.300	1.600
1210	1210K	50	57	83	1.0	0.5250	0.5150	H210	0.200	3.100	4.900	3.300
2210	2210K		57	83	1.0	0.5900	0.5770	H310	0.290	2.200	3.400	2.300
1310	1310K		60	100	2.0	1.2100	1.1900	H310	0.240	2.700	4.100	2.800
1211	1211K	55	62	91	1.5	0.7050	0.6930	H211	0.200	3.200	5.000	3.400
2211	2211K		62	91	1.5	0.8100	0.7920	H311	0.280	2.300	3.500	2.400
1212	1212K	60	67	101	1.5	0.9000	0.8850	H212	0.190	3.400	5.300	3.600
2212	2212K		67	101	1.5	1.0900	1.0700	H312	0.280	2.300	3.500	2.400
1312	1312K		72	118	2.0	1.9600	1.9300	H312	0.230	2.800	4.300	2.900

Double Row Self-Aligning Ball Bearings

d = 65 to 150 mm

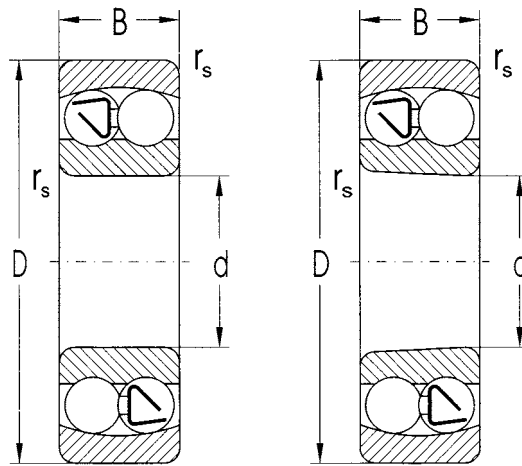

K

E

Dimension					Basic Load Rating				Limiting Speed for Lubrication with		Bearing Designation	
d	D	B	B ₁ ¹⁾	r _s	Dynamic C _r	Static C _{0r}	Dynamic C _r	Static C _{0r}	Grease	Oil	with Cylindrical Bore	with Tapered Bore
mm					kN	kN	lbs.	lbs.	rpm			
65	120	23	-	1.5	31.200	12.300	7,014	2,765	5,300	6,300	1213	1213K
	120	31	-	1.5	43.600	16.500	9,801	3,679	5,300	6,300	2213	2213K
70	125	31	-	1.5	44.200	17.100	9,936	3,844	5,000	6,000	2214	
	150	51	-	2.1	111.000	37.600	4,953	8,452	3,800	4,500	2314	
75	130	25	-	1.5	39.000	15.500	8,767	3,484	4,700	5,600	1215	1215K
	130	31	-	1.5	44.200	17.800	9,936	4,001	4,700	5,600	2215	2215K
	160	37	-	2.1	79.300	29.900	17,827	6,721	3,800	4,500	1315	1315K
	160	55	-	2.1	124.000	43.000	27,876	9,666	3,500	4,200	2315	2315K
80	140	26	-	2.0	39.700	16.800	8,924	3,776	4,500	5,300	1216	1216K
	140	33	-	2.0	48.800	20.000	10,970	4,496	4,500	5,300	2216	2216K
85	150	28	-	2.0	48.800	20.300	10,970	4,563	4,000	4,700	1217	1217K
	180	41	-	3.0	97.500	37.600	21,918	8,452	3,300	4,000	1317	1317K
	180	60	-	3.0	140.000	51.100	31,473	11,487	3,200	3,800	2317	2317K
90	160	30	-	2.0	57.200	23.300	12,859	5,238	3,800	4,500	1218	1218K
	160	40	-	2.0	70.200	28.700	15,871	6,452	3,800	4,500	2218	2218K
	190	64	-	3.0	153.000	57.300	34,395	12,881	3,000	3,500	2318	2318K
95	170	32	-	2.1	63.700	27.100	14,320	6,092	3,500	4,200	1219	1219K
	170	43	-	2.1	83.200	34.100	18,704	7,665	3,500	4,200	2219	2219K
	200	45	48	3.0	133.000	51.100	29,899	11,487	3,000	3,500	1319	1319K
	200	67	-	3.0	165.000	64.300	37,093	14,455	2,800	3,300	2319	2319K
100	180	34	-	2.1	68.900	29.300	15,489	6,586	3,300	4,000	1220	1220K
	180	46	-	2.1	97.500	40.600	21,918	9,127	3,300	4,000	2220	2220K
	215	47	52	3.0	143.000	58.400	32,147	13,128	2,800	3,300	1320	1320K
	215	73	-	3.0	190.000	77.900	42,713	17,512	2,700	3,200	2320	2320K
110	200	38	-	2.1	88.400	38.300	19,873	8,610	3,000	3,500	1222	1222K
	200	53	-	2.1	124.000	52.100	27,876	11,712	3,000	3,500	2222	2222K
	240	50	55	3.0	163.000	70.800	36,643	15,916	2,700	3,200	1322	1322K
	240	80	-	3.0	216.000	94.400	48,558	21,221	2,500	3,000	2322	2322K
120	215	42	45	2.1	119.000	52.100	26,752	11,712	2,800	3,300	1224	
130	230	46	48	3.0	126.000	59.600	28,325	13,398	2,700	3,200	1226	
140	250	50	54	3.0	159.000	72.200	35,744	16,231	2,500	3,000	1228	
150	270	54	56	3.0	171.000	85.800	38,442	19,288	2,400	2,800	1230	

¹⁾ The dimension B₁ indicates the bearing width measured over balls if they protrude from the bearing side faces

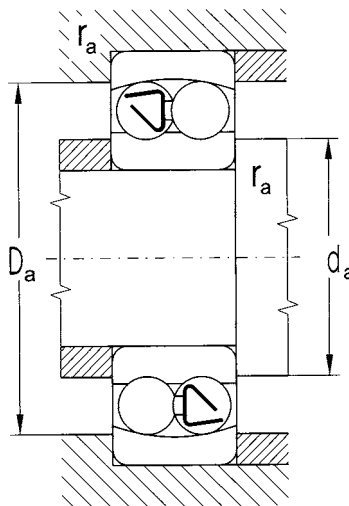

Abutment and Fillet Dimensions				Weight		Corresponding Adapter Sleeve	Factors			
d	d _a min	D _a max	r _a max		K		e	Y ₁	Y ₂	Y ₀
mm				kg						
65	72	111	1.5	1.150	1.130	H213	0.170	3.700	5.700	3.900
	72	11	1.5	1.460	1.430	H313	0.280	2.200	3.500	2.300
70	77	116	1.5	1.520	-	-	0.270	2.400	3.700	2.500
	81	138	2	3.900	-	-	0.380	1.700	2.600	1.800
75	82	121	1.5	1.360	1.340	H215	0.180	3.600	5.600	3.800
	82	121	1.5	1.620	1.580	H315	0.250	2.500	3.900	2.600
	86	148	2	3.560	3.510	H315	0.220	2.800	4.400	3.000
	86	148	2	4.720	4.610	H2315	0.380	1.700	2.600	1.700
80	90	130	2	1.670	1.640	H216	0.160	3.900	6.100	4.100
	90	130	2	2.010	1.970	H316	0.250	2.500	3.900	2.600
85	95	140	2	2.070	2.040	H217	0.170	3.700	5.700	3.900
	98	166	2.5	4.980	4.910	H317	0.220	2.900	4.500	3.000
	98	166	2.5	6.710	6.550	H2317	0.370	1.700	2.700	1.800
90	100	150	2	2.520	2.480	H218	0.170	3.800	5.800	3.900
	100	150	2	3.200	3.130	H318	0.270	2.400	3.600	2.500
	103	176	2.5	7.960	7.770	H2318	0.380	1.700	2.600	1.800
95	107	158	2	3.100	3.050	H219	0.170	3.700	5.700	3.900
	107	158	2	3.950	3.850	H319	0.270	2.400	3.600	2.500
	109	186	2.5	6.690	6.590	H319	0.230	2.800	4.300	2.900
	109	186	2.5	9.210	8.990	H2319	0.380	1.700	2.600	1.800
100	112	168	2	3.700	3.640	H220	0.170	3.600	5.600	3.800
	112	168	2	4.720	4.610	H320	0.270	2.400	3.600	2.500
	113	201	2.5	8.300	8.19	H320	0.24	2.700	4.100	2.800
	113	201	2.5	11.700	11.400	H2320	0.380	1.700	2.600	1.700
110	122	188	2	5.150	5.070	H222	0.170	3.600	5.600	3.800
	122	188	2	6.840	6.680	H322	0.280	2.300	3.500	2.400
	124	226	2.5	11.800	11.700	H322	0.220	2.800	4.400	3.000
	124	226	2.5	17.300	16.900	H2322	0.370	1.700	2.700	1.800
120	120	203	2	6.750	-	-	0.190	3.300	5.100	3.400
130	144	216	2.5	8.300	-	-	0.190	3.300	5.000	3.400
140	154	236	2.5	10.900	-	-	0.200	3.100	4.800	3.300
150	164	256	2.5	13.800	-	-	0.190	3.200	5.000	3.400

Double Row Self-Aligning Ball Bearings for Special Applications

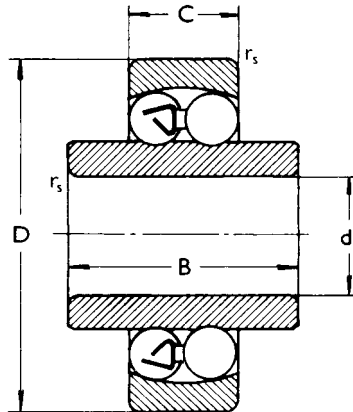

Dimension					Basic Load Rating			
d	D	B	C	r _s min	Dynamic C _r	Static C _{or}	Dynamic C _r	Static C _{or}
mm					kN	kN	lbs.	lbs.
6	19	10	6	0.3	1.930	0.482	434	108
	19	14	6	0.3	1.930	0.482	434	108
8	22	14	7	0.3	2.040	0.562	459	126
	26	18	8	0.3	2.900	0.810	652	182
10	30	20	9	0.6	4.150	1.190	933	268
12	32	24	10	0.6	4.300	1.260	967	283

Limiting Speed for Lubrication with		Bearing Designation	Axial Clearance		Weight
Grease	Oil		min	max	
rpm			μm		kg
25,000	32,000	PLC 11-2	60	160	0.012
25,000	32,000	PLC 11-3	60	160	0.013
25,000	32,000	PLC 11-4	60	160	0.020
25,000	32,000	PLC 12-2	60	160	0.028
24,000	30,000	PLC 12-3	80	180	0.046
22,000	28,000	PLC 13-3	80	180	0.058

This page left blank intentionally.

Single Row Cylindrical Roller Bearings

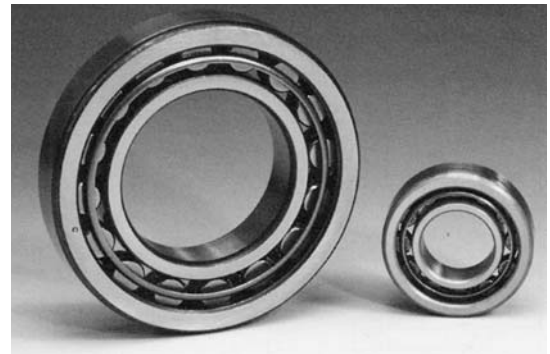

Single row cylindrical roller bearings are manufactured in several basic separable designs, with different guide flange locations to achieve a variety of capabilities. With higher basic load ratings in comparison to single row ball bearings of the same size, single row cylindrical roller bearings are especially suitable for use in applications with heavy radial loads, high speeds, and where interference fits are required on both bearing rings.

The NU design features two guided flanges on the outer ring and the N design features two guide flanges on the inner ring. Both allow mutual displacement of the inner and outer rings in either direction. The NJ design has two guide flanges on the outer ring and one on the inner, to handle axial loads in one direction. The NUP design has all of the same features as the NJ design, in addition to a loose guide flange for the inner ring, to carry axial loads in both directions. Axial guiding can also be achieved through the use of an HJ series angle ring in both directions with an NH series bearing, and in one direction with an NU series design. Bearings with the design of NFD, full complement bearings without a cage, are also available in selected sizes.

Selected sizes of ZVL-ZKL single row cylindrical roller bearings are available in the E design; additional sizes are gradually being introduced into standard production. The E designation stands for "extra capacity" and has an increased load-carrying capability.

Cage

Single row cylindrical roller bearings are produced with steel, brass (M), or polyamide (TNG) cages.

Boundary Dimensions

Boundary dimensions comply with the standard ISO 15.

Tolerance

All single row cylindrical roller bearings are produced with ABEC 1 or P0 tolerances. For applications where more precise tolerances are needed, tolerance classes ABEC 3, ABEC 5, or ABEC 7 (P6, P5, or P4) should be used. Please consult with ZVL-ZKL for availability of these bearings with these high tolerance classes. All of these tolerances comply with standard ISO 199 and ISO 492.

Radial Clearance

Single row cylindrical roller bearings are commonly produced with C0 or C3 radial clearance. Please consult ZVL-ZKL for availability of other radial clearance ranges. All radial clearance values comply with standard ISO 5753 and are listed in the chart below.

Radial Clearance of Single Row Cylindrical Roller Bearings											
Bore Diameter		Radial Clearance									
d		C2		normal		C3		C4		C5	
over	to	min	max	min	max	min	max	min	max	min	max
mm		µm									
10	24	0	25	20	45	35	60	50	75	65	90
24	30	0	25	20	45	35	60	50	75	70	95
30	40	5	30	25	50	45	70	60	85	80	105
40	50	5	35	30	60	50	80	70	100	95	125
50	65	10	40	40	70	60	90	80	110	110	140
65	80	10	45	40	75	65	100	90	125	130	165
80	100	15	50	50	85	75	110	105	140	155	190
100	120	15	55	50	90	85	125	125	165	180	220
120	140	15	60	60	105	100	145	145	190	200	245
140	160	20	70	70	120	115	165	165	215	225	275
160	180	25	75	75	125	120	170	170	220	250	300
180	200	35	90	90	145	140	195	195	250	275	330
200	225	45	105	105	165	160	220	220	280	305	365
225	250	45	110	110	175	170	235	235	300	330	395
250	280	55	125	125	195	190	260	260	330	370	440
280	315	55	130	130	205	200	275	275	350	410	485
315	355	65	145	145	225	225	305	305	385	455	535
355	400	100	190	190	280	280	370	370	460	510	600
400	450	110	210	210	310	310	410	410	510	565	665
450	500	110	220	220	330	330	440	440	550	625	735
500	560	120	240	240	360	360	480	480	600	695	815
560	630	140	260	260	380	380	500	500	620	780	900
630	710	145	285	285	425	425	565	565	705	870	1010
710	800	150	310	310	470	470	630	630	790	980	1140
800	900	180	350	350	520	520	690	690	860	1100	1270
900	1000	200	390	390	580	580	770	770	960	1220	1410
1000	1120	220	430	430	640	640	850	850	1060	1360	1570
1120	1250	230	470	470	710	710	950	950	1190	1520	1760

F

Vibration Level

All single row cylindrical roller bearings are 100% checked for noise and vibration during manufacturing. When special vibration levels are required, bearings with tolerance class P5 and special internal design changes can be produced. These bearings are noted by the designation C6.

Bearings with Angle Rings

Angle rings, type HJ10, HJ2, HJ2E, HJ3, HJ3E and HJ4, can be used with bearings NJ and NU.

Examples of bearing designation :

- NJ10 +HJ10 =NH10
- NJ2 +HJ2 =NH2
- NJ3 +HJ3 =NH3
- NJ4 +HJ4 =NH4

- NU10 +HJ10 =NUJ10
- NU2 +HJ2 =NUJ2
- NU3 +HJ3 =NUJ3
- NU4 +HJ4 =NUJ4

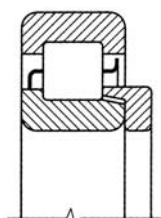

NH

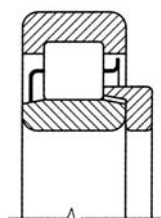

NUJ

Bearings without Inner Ring

In applications where space for bearing mounting is limited, single row cylindrical roller bearings without inner rings, designated R NU, can be used. The bearing's outer ring and rollers are mounted directly to the shaft which now becomes the inner ring and raceway.

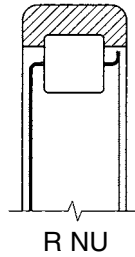

Dimension tolerances on the shaft are usually a “g6” for normal radial clearance, “f6” for a higher radial clearance, and “h5” for a smaller radial clearance. Cylindricity deviations of the shaft must not be greater than tolerances of a class IT3. Surface roughness values should be $R_a = 0.2$ and $R_a = 0.4$ for less-demanding applications.

Basic load ratings C_r and C_{or} values are still valid for R NU bearings as long as shaft surface hardness is in the range of 59 to 65 HRC. As hardness decreases, the load rating values also decrease. The following table is a multiplier that should be used when the shaft hardness values drop to those listed.

Hardness HRC	58	56	54	51	48	45	40	35	30
Factor f_h	0.9	0.8	0.7	0.6	0.5	0.4	0.3	0.25	0.2

Misalignment

The allowable misalignment for single row cylindrical roller bearings is very small. See the table below for actual values of permissible misalignment.

Bearing Type	Load	
	Small ($F_r < 0.1C_{or}$)	Large ($F_r \geq 0.1C_{or}$)
NU10, NU2, NU3, NU4	2' to 3'	5' to 7'
NU29, NU22, NU23	1' to 3'	3' to 4'
Designs NJ, NUP, N ¹⁾ of all dimension series	1' to 2'	3' to 4'

¹⁾ Smaller values of the number pair are valid for bearings of width series 2 and higher.

Radial Equivalent Dynamic Load

$$P_r = F_r$$

[kN]

Axial Dynamic Load Rating

Cylindrical roller bearings with ribs on both rings can carry a limited axial load. Because the permissible axial load depends on many factors which cannot be expressed in a simple calculation, the following relationships have been developed for a quick reference.

The axial load capabilities, in this case, are not limited by the material fatigue. The lubrication film on the contact surface between the cylindrical roller face and guiding rib determines them. The lubrication conditions and operating temperatures also contribute to this permissible load. At common working conditions when the difference of the bearing and environmental temperature does not exceed 140°F, by slight heat transfer, by viscosity relation χ 1.5, it is possible to calculate the maximum permissible axial load from this equation:

-for oil lubrication

$$F_{a \max} = \frac{0.5C_{or} \cdot 10^4}{n (d + D)} - 0.05 F_r \quad [\text{kN}]$$

-for grease lubrication

$$F_{a \max} = \frac{0.35C_{or} \cdot 10^4}{n (d + D)} - 0.03 F_r \quad [\text{kN}]$$

$F_{a \max}$	- maximum permissible axial load	[kN]
C_{or}	- radial basic static load rating	[kN]
F_r	- radial bearing load	[kN]
n	- rotational speed	[rpm]
d	- bearing bore diameter	[mm]
D	- bearing outside diameter	[mm]

Values for $F_{a \max}$ calculated according to the above-mentioned equations are valid under the assumption of continuously acting axial forces. For intermittent or impact loading, the permissible axial load can be two or three times greater in comparison with the calculated value. For a reliable bearing life, it is important that the ratio = F_a/F_r 0.4.

Radial Equivalent Static Load

$$P_{or} = F_r \quad [\text{kN}]$$

Designation

Listed below are some common designations for single row cylindrical roller bearings.

Single Row Cylindrical Roller Bearings		
Prefix	Description	Example of Designation
R	Separable bearing without the removable bearing ring	R NU219
Suffix	Description	Example of Designation
E	Internal design change for enhanced load carrying capacity	NU2215 E
N	Snap ring groove on the outer ring	NU314 N
M	Machined brass cage guided on the rolling elements	NJ312 M
MA	Machined brass cage guided on the outer ring	NU226 MA
MAS	Machined brass cage guided on the outer ring with lubrication holes	NJ2308E MAS
MB	Machined brass cage guided on the inner ring	N313 MB
TNG	Polyamide cage reinforced with glass fiber, guided on the rolling elements	NUP310E TNG
P6	Higher tolerance class than normal	N212 P6
P5	Higher tolerance class than P6	N320 P5
P4	Higher tolerance class than P5	NUP2324 P4
C1	Radial clearance less than C2	NJ204 C1
C2	Radial clearance less than normal	NU211 C2
C3	Radial clearance greater than normal	NJ313 C3
C4	Radial clearance greater than C3	NU220 C4
C5	Radial clearance greater than C4	NU234E C5
NA	Radial clearance for bearings with non-interchangeable rings	NU224 NA
S0	Heat stabilized for an operating temperature up to 302°F (150°C)	NU220 S0
S1	Heat stabilized for an operating temperature up to 392°F (200°C)	NJ318 S1
S2	Heat stabilized for an operating temperature up to 482°F (250°C)	N412 S2
S3	Heat stabilized for an operating temperature up to 572°F (300°C)	NJ2215E S3
S4	Heat stabilized for an operating temperature up to 662°F (350°C)	NUP228 S4
S5	Heat stabilized for an operating temperature up to 752°F (400°C)	NU5234M C3S5

F

Single Row Cylindrical Roller Bearings

d = 20 to 40 mm

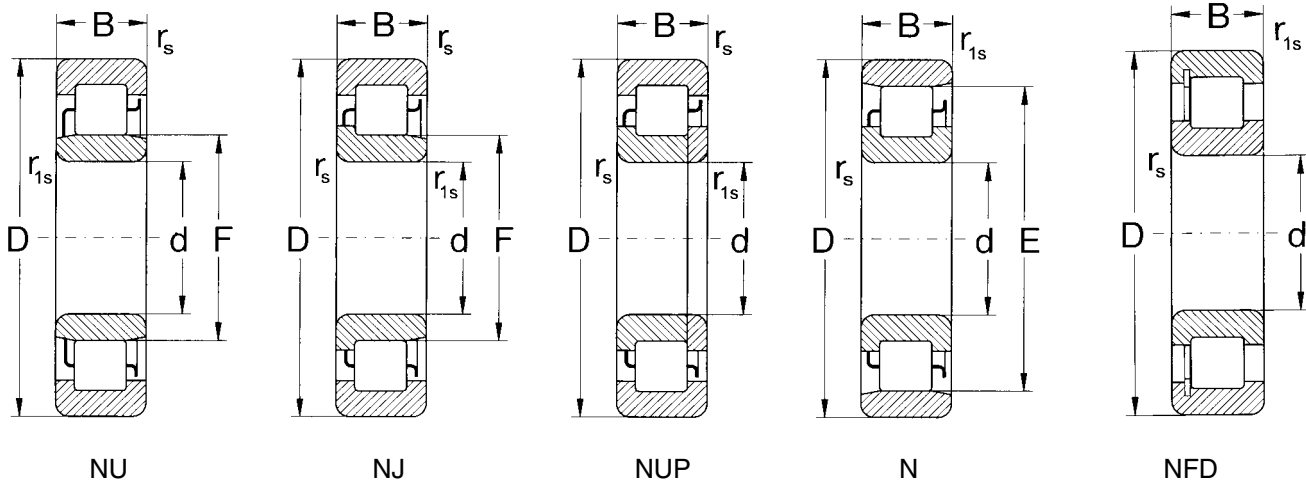

NU

NJ

NUP

N

NFD

NU + HJ = NUJ

NJ + HJ = NH

F

Dimension											Bearing Designation				Angle Ring
d	D	B	r _s min	r _{1s} min	F	E	d ₂ max	b	b ₁	s ¹⁾	NU / NUJ	NJ / NH	NUP	N / NFD	HJ
mm															
20	47	14.0	1.00	0.6	27.0	-	-	-	-	1.4	NU204ETNG	NJ204ETNG			
47	14.0	1.00	0.6	27.0	40.0	30.0	3	6.75	1.4		NU204	NJ204	NUP204	N204	HJ204
25	52	15.0	1.00	0.6	31.5	-	34.9	3	6.00	1.4	NU205	NJ205	NUP205	N205	HJ205
52	15.0	1.00	0.6	31.5	-	34.9	3	6.00	1.4		NU205E	NJ205E	NUP205E		HJ205E
52	15.0	1.00	0.6	31.5	46.5	34.9	3	6.00	1.4		NU205ETNG	NJ205ETNG	NUP205ETNG	N205ETNG	HJ205E
52	18.0	1.00	0.6	31.5	-	-	-	-	1.6		NU2205E	NJ2205E			
52	18.0	1.00	0.6	32.0	-	-	-	-	1.6		NU2205	NJ2205	NUP2205		
62	17.0	1.10	1.1	35.0	53.0	39.3	4	8.00	1.4		NU305	NJ305		N305	HJ305
62	17.0	1.10	1.1	34.0	-	38.3	4	7.00	1.4		NU305EMAS	NJ305EMAS	NUP305EMAS		HJ305E
62	17.0	1.10	1.1	34.0	54.0	38.3	4	7.00	1.4		NU305ETNG	NJ305ETNG	NUP305ETNG	N305ETNG	HJ305E
80	21.0	1.50	1.5	38.8	-	-	-	-	1.4		NU405	NJ405			
30	62	16.0	1.00	0.6	38.5	53.5	42.2	4	8.25	1.5	NU206	NJ206	NUP206	N206	HJ206
62	16.0	1.00	0.6	37.5	55.5	41.4	4	7.00	1.4		NU206ETNG	NJ206ETNG	NUP206ETNG	N206ETNG	HJ206E
62	20.0	1.00	0.6	38.5	-	-	-	-	1.6		NU2206	NJ2206	NUP2206		
72	19.0	1.10	1.1	42.0	62.0	46.6	5	9.50	1.4		NU306	NJ306	NUP306	N306	HJ306
72	19.0	1.10	1.1	40.5	-	45.1	5	8.50	1.4		NU306E	NJ306E	NUP306E		HJ306E
72	19.0	1.10	1.1	40.5	62.5	45.1	5	8.50	1.4		NU306ETNG	NJ306ETNG	NUP306ETNG	N306ETNG	HJ306E
90	23.0	1.50	1.5	45.0	-	51.4	7	11.50	1.5		NU406	NJ406	NUP406		HJ406
32	65	21.0	1.00	0.6	38.5	-	-	-	1.6		NU22/32ETNG				
35	72	17.0	1.10	0.6	43.8	61.8	48.1	4	8.00	1.5	NU207	NJ207	NUP207	N207	HJ207
72	17.0	1.10	0.6	44.0	-	48.3	4	7.00	1.4		NU207E	NJ207E	NUP207E		HJ207E
72	17.0	1.10	0.6	44.0	64.0	48.3	4	7.00	1.4		NU207ETNG	NJ207ETNG	NUP207ETNG	N207ETNG	HJ207E
72	23.0	1.10	0.6	43.8	-	-	-	-	1.6		NU2207	NJ2207	NUP2207		
72	23.0	1.10	0.6	44.0	-	-	-	-	1.6		NU2207ETNG	NJ2207ETNG	NUP2207ETNG		
80	21.0	1.50	1.1	46.2	68.2	51.2	6	11.00	1.4		NU307	NJ307	NUP307	N307	HJ307
80	21.0	1.50	1.1	46.2	-	51.2	6	9.50	1.4		NU307E	NJ307E	NUP307E		HJ307E
80	31.0	1.50	1.1	46.2	-	-	-	-	2.7		NU2307EMAS	NJ2307EMAS	NUP2307EMAS		
100	25.0	1.50	1.5	53.0	83.0	59.9	8	13.00	1.5		NU407	NJ407	NUP407	N407	HJ407
40	80	18.0	1.10	1.1	50.0	70.0	54.6	5	9.00	1.5	NU208	NJ208	NUP208	N208	HJ208
80	18.0	1.10	1.1	49.5	-	54.1	5	8.50	1.4		NU208E	NJ208E	NUP208E		HJ208E
80	23.0	1.10	1.1	49.5	-	-	-	-	1.6		NU2208E	NJ2208E			
80	23.0	1.10	1.1	50.0	-	-	-	-	1.6		NU2208	NJ2208	NUP2208		
80	23.0	1.10	-	-	71.1	-	-	-	1.0					NFD2208V	
80	30.16	1.00	1.5	49.3	-	-	-	-	3.0		NU5208M				
90	23.0	1.50	1.5	53.5	77.5	59.0	7	12.50	1.4		NU308	NJ308	NUP308	N308	HJ308
90	23.0	1.50	1.5	52.0	-	57.7	7	11.00	1.4		NU308E	NJ308E	NUP308E		HJ308E
90	23.0	1.50	1.5	52.0	80.0	57.7	7	11.00	1.4		NU308ETNG	NJ308ETNG	NUP308ETNG	N308ETNG	HJ308E
90	33.0	1.50	1.5	52.0	-	-	-	-	2.9		NU2308EMAS	NJ2308EMAS	NUP2308EMAS		
110	27.0	2.00	2.0	58.0	92.0	65.8	8	13.00	1.5		NU408	NJ408	NUP408	N408	HJ408

¹⁾ Permissible axial displacement out of central position

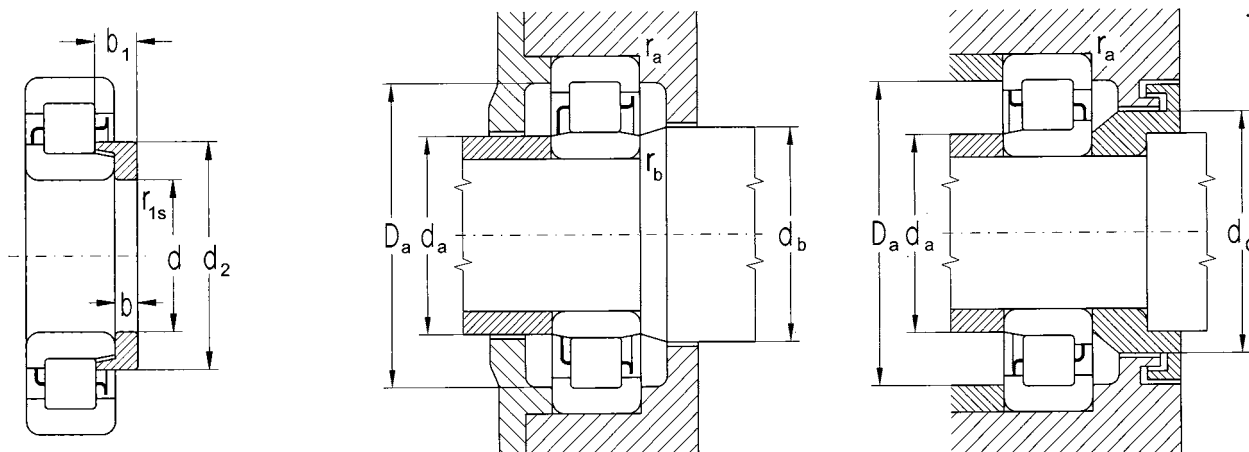

HJ

F

Basic Load Rating				Limiting Speed for Lubrication with		Abutment and Fillet Dimensions										Weight	
Dynamic C _r	Static C _{0r}	Dynamic C _r	Static C _{0r}	Grease	Oil	d	d _a min	d _a max	d _b min	d _c min	d _d max	D _a max	D _b min	r _a max	r _b max	Bearing	Angle Ring
kN	kN	lbs.	lbs.	rpm		mm										kg	
13.900	10.200	3,125	2,293	14,000	17,000	20	25	25.5	29	32	39	42	42	1.0	0.6	0.170	-
27.400	24.700	6,160	5,553	14,000	17,000	25	25	25.5	29	32	39	42	42	1.0	0.6	0.110	0.01
15.800	12.600	3,552	2,833	12,600	15,000	25	30	30.5	34	37	43	47	47	1.0	0.6	0.130	0.02
29.300	25.600	6,587	5,755	12,600	15,000	30	30	30	34	37	-	47	-	1.0	0.6	0.128	0.02
29.300	25.600	6,587	5,755	12,600	15,000	30	30	30	34	37	44	47	47	1.0	0.6	0.128	0.02
34.800	34.600	7,823	7,778	12,000	14,000	30	30	30	34	37	-	47	-	1.0	0.6	0.500	-
22.400	19.600	5,036	4,406	12,600	15,000	30	30.5	30.5	34	37	-	47	-	1.0	0.6	0.160	-
27.600	21.500	6,205	4,833	10,000	12,000	31	33	33	37	40	51	55	55	1.0	1.0	0.240	0.03
43.000	36.200	9,667	8,138	10,000	12,000	31	32	32	37	40	-	55	-	1.0	1.0	0.255	0.03
43.000	36.200	9,667	8,138	10,000	12,000	31	32	32	36	39	52	55	55	1.0	1.0	0.237	0.03
43.800	34.100	9,847	7,666	8,400	10,000	32	38	38	39	40	-	73	-	1.0	1.0	0.565	-
21.500	17.800	4,833	4,002	10,600	12,600	30	35	35	40	44	52	57	56	1.0	0.6	0.200	0.03
39.100	35.500	8,790	7,981	10,600	12,600	35	37	37	40	43	54	57	57	1.0	0.6	0.198	0.03
31.600	29.300	7,104	6,587	10,600	12,600	35	37	37	40	44	-	57	-	1.0	0.6	0.260	-
36.200	31.000	8,138	6,969	8,900	10,600	36	39	39	44	48	60	65	64	1.0	1.0	0.360	0.04
53.100	46.400	11,937	10,431	8,400	10,000	36	37.5	37.5	43	47	-	65	-	1.0	1.0	0.357	0.04
53.100	46.400	11,937	10,431	8,400	10,000	36	37.5	37.5	43	47	60	65	64	1.0	1.0	0.357	0.04
59.600	48.200	13,399	10,836	7,100	8,400	39	41	41	47	53	-	80	-	1.5	1.5	0.750	0.08
51.100	50.100	11,488	11,263	10,000	12,000	32	35	35	39	43	-	60	-	1.0	1.0	0.309	-
31.600	27.100	7,104	6,092	9,400	11,000	35	42	42	46	50	60	65	64	1.0	0.6	0.292	0.04
51.100	48.200	11,488	10,836	8,900	10,600	42	42	42	46	50	-	65	-	1.0	0.6	0.292	0.04
51.100	48.200	11,488	10,836	8,900	10,600	42	42	42	46	50	62	65	65	1.0	0.6	0.292	0.04
48.200	47.300	10,836	10,634	9,400	11,000	42	42	42	46	50	-	65	-	1.0	0.6	0.400	-
64.300	64.300	14,455	14,455	8,900	10,600	42	42	42	46	50	-	65	-	1.0	0.6	0.385	-
43.000	36.200	9,667	8,138	7,900	9,400	42	44	44	48	53	66	71	71	1.5	1.0	0.480	0.06
66.800	61.900	15,017	13,916	7,500	8,900	42	44	44	48	53	-	71	-	1.5	1.0	0.466	0.06
92.600	92.600	20,817	20,817	7,100	8,400	42	44	44	48	53	-	71	-	1.5	1.0	0.751	-
75.000	64.300	16,861	14,455	6,300	7,500	49	52	52	55	62	81	90	86	1.5	1.5	1.000	0.13
42.200	37.600	9,487	8,453	7,900	9,400	40	47	47	52	56	68	73	72	1.0	1.0	0.370	0.05
54.100	50.100	12,162	11,263	7,900	9,400	47	47	47	51	56	-	73	-	1.0	1.0	0.380	0.05
71.000	75.000	15,962	16,861	7,500	8,900	47	48	48	52	56	-	73	-	1.0	1.0	0.520	-
57.300	56.200	12,882	12,634	7,900	9,400	47	48	48	52	56	-	73	-	1.0	1.0	0.490	-
81.000	90.000	18,210	20,233	2,200	4,100	47	48	48	52	56	-	73	-	1.0	1.0	0.560	-
57.000	98.100	12,814	22,054	7,500	8,900	48	-	-	51.5	-	-	72	-	1.5	1.5	0.738	-
55.200	48.200	12,410	10,836	7,100	8,400	47	51	51	55	61	75	81	81	1.5	1.5	0.660	0.09
84.100	77.900	18,907	17,513	6,700	7,900	47	50	50	54	60	-	81	-	1.5	1.5	0.670	0.08
84.100	77.900	18,907	17,513	6,700	7,900	47	50	50	54	60	77	81	81	1.5	1.5	0.829	0.08
119.000	123.000	26,752	27,652	6,300	7,500	47	50	50	54	60	-	81	-	1.5	1.5	1.000	-
92.600	79.400	20,817	17,850	5,600	6,700	50	55	55	60	68	90	97	95	2.0	2.0	1.300	0.14

Single Row Cylindrical Roller Bearings

d = 45 to 60 mm

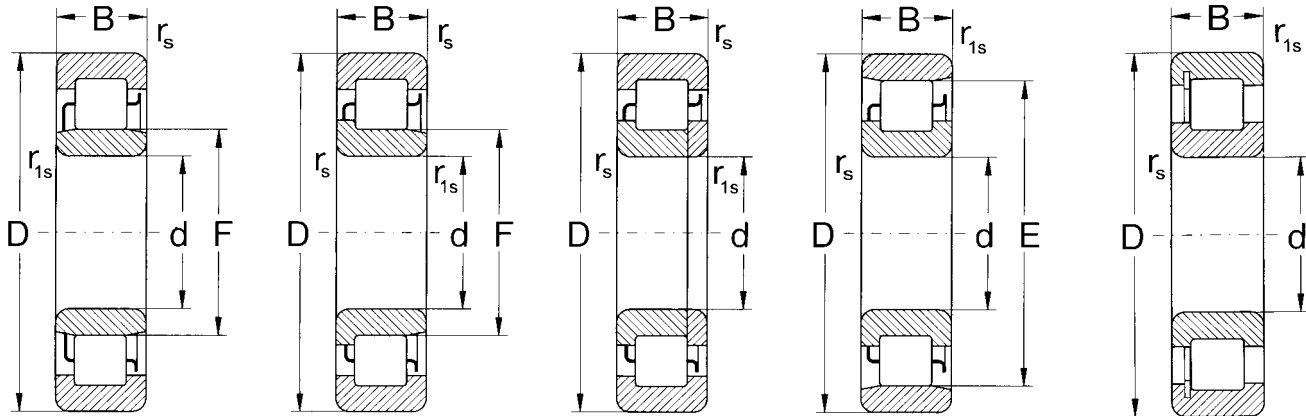

NU

NJ

NUP

N

NFD

NU + HJ = NUJ

NJ + HJ = NH

F

Dimension											Bearing Designation				Angle Ring
d	D	B	r _s min	r _{1s} min	F	E	d ₂ max	b	b ₁	s ¹⁾	NU / NUJ	NJ / NH	NUP	N / NFD	HJ
mm															
45	85	19.00	1.1	1.1	55.00	75.0	59.6	5	9.50	1.5	NU209	NJ209	NUP209	N209	HJ209
	85	19.00	1.1	1.1	54.50	-	59.1	5	8.50	1.4	NU209E	NJ209E	NUP209E	-	HJ209E
	85	19.00	1.1	1.1	54.50	76.5	59.1	5	8.50	1.4	NU209ETNG	NJ209ETNG	NUP209ETNG	N209ETNG	HJ209E
	85	23.00	1.1	1.1	54.50	-	-	-	-	1.6	NU2209E	NJ2209E	NUP2209E	-	-
	85	23.00	1.1	1.1	54.50	-	-	-	-	1.6	NU2209ETNG	NJ2209ETNG	NUP2209ETNG	-	-
	85	30.16	1.0	1.5	55.52	-	-	-	-	4.0	NU5209M	-	-	-	-
	100	25.00	1.5	1.5	58.50	86.5	65.0	7	12.50	1.4	NU309	NJ309	NUP309	N309	HJ309
	100	25.00	1.5	1.5	58.50	-	64.6	7	11.50	1.4	NU309E	NJ309E	NUP309E	-	HJ309E
	100	36.00	1.5	1.5	58.50	-	-	-	-	2.9	NU2309E	NJ2309E	NUP2309E	-	-
	120	29.00	2.0	2.0	64.50	100.5	72.8	8	13.50	1.5	NU409	NJ409	NUP409	N409	HJ409
50	90	20.00	1.1	1.1	60.40	80.4	65.0	5	10.00	1.6	NU210	NJ210	NUP210	N210	HJ210
	90	20.00	1.1	1.1	59.50	-	64.6	5	9.00	1.6	NU210E	NJ210E	NUP210E	-	HJ210E
	90	20.00	1.1	1.1	59.50	81.5	-	-	-	1.6	NU210ETNG	NJ210ETNG	-	-	-
	90	23.00	1.1	1.1	60.40	-	-	-	-	1.6	NU2210	NJ2210	NUP2210	-	-
	90	23.00	1.1	1.1	59.50	-	-	-	-	1.6	NU2210E	NJ2210E	NUP2210E	-	-
	90	30.16	1.0	1.5	60.46	-	-	-	-	4.5	NU5210M	-	-	-	-
	110	27.00	2.0	2.0	65.00	95.0	71.9	8	14.00	1.5	NU310	NJ310	NUP310	N310	HJ310
	110	27.00	2.0	2.0	65.00	97.0	71.4	8	13.00	1.5	NU310ETNG	NJ310ETNG	NUP310ETNG	N310ETNG	HJ310E
	110	40.00	2.0	2.0	65.00	-	-	-	-	3.0	NU2310	NJ2310	NUP2310	-	-
	110	40.00	2.0	2.0	65.00	-	-	-	-	3.0	NU2310EMAS	NJ2310EMAS	NUP2310EMAS	-	-
	130	31.00	2.1	2.1	70.80	110.8	80.0	9	14.50	2.0	NU410	NJ410	NUP410	N410	HJ410
55	100	21.00	1.5	1.1	66.50	88.5	71.5	6	11.00	1.6	NU211	NJ211	NUP211	N211	HJ211
	100	21.00	1.5	1.1	66.00	-	71.0	6	9.50	1.6	NU211E	NJ211E	NUP211E	-	HJ211E
	100	25.00	1.5	1.5	66.00	-	-	-	-	1.6	NU2211E	NJ2211E	-	-	-
	100	25.00	1.5	1.1	66.50	-	-	-	-	1.6	NU2211	NJ2211	NUP2211	-	-
	100	33.34	1.5	2.1	66.90	-	-	-	-	4.5	NU5211M	-	-	-	-
	120	29.00	2.0	2.0	70.50	104.5	78.4	9	15.00	1.5	NU311	NJ311	NUP311	N311	HJ311
	120	29.00	2.0	2.0	70.50	-	77.7	9	14.00	1.5	NU311E	NJ311E	NUP311E	-	HJ311E
	120	29.00	2	2	70.50	106.5	-	-	-	1.5	NU311ETNG	NJ311ETNG	-	-	-
	140	33.00	2.1	2.1	77.20	117.2	86.4	10	16.60	3.0	NU411	NJ411	NUP411	N411	HJ411
60	110	22.00	1.5	1.5	73.50	97.5	79.0	6	11.00	1.6	NU212	NJ212	NUP212	N212	HJ212
	110	22.00	1.5	1.5	72.00	-	-	-	-	1.6	-	NJ212ETNG	NUP212ETNG	-	-
	110	22.00	1.5	1.5	72.00	-	-	-	-	1.6	NU212EM	NJ212EM	-	-	-
	110	28.00	1.5	1.5	72.00	-	-	-	-	1.6	-	NJ2212ETNG	NUP2212ETNG	-	-
	110	28.00	1.5	1.5	73.50	-	-	-	-	1.6	NU2212	NJ2212	NUP2212	-	-
	110	36.50	1.5	2.0	72.38	-	-	-	-	4.5	NU5212M	-	-	-	-
	130	31.00	2.1	2.1	77.00	113.0	85.3	9	15.50	1.5	NU312	NJ312	NUP312	N312	HJ312
	130	46.00	2.1	2.1	77.00	-	-	-	-	4.5	NU2312	NJ2312	NUP2312	-	-
	150	35.00	2.1	2.1	83.00	127.0	93.1	10	16.50	2.0	NU412	NJ412	NUP412	N412	HJ412

¹⁾ Permissible axial displacement out of central position

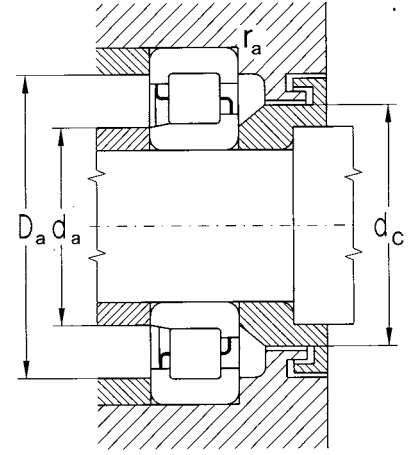
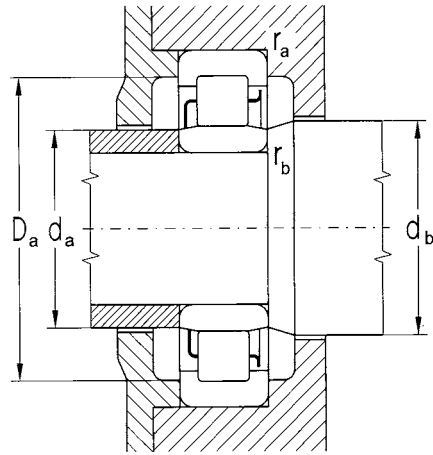
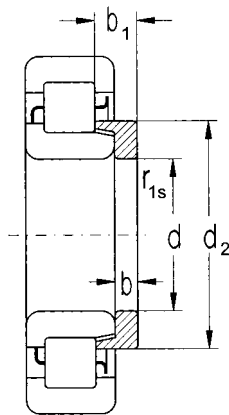

HJ

F

Basic Load Rating				Limiting Speed for Lubrication with		Abutment and Fillet Dimensions										Weight	
Dynamic C_r	Static C_{or}	Dynamic C_r	Static C_{or}	Grease	Oil	d	d_a min	d_a max	d_b min	d_c min	d_d max	D_a max	D_b min	r_a max	r_b max	Bearing	Angle Ring
kN	kN	lbs.	lbs.	rpm		mm										kg	
43.800	41.100	9,847	9,240	7,500	8,900	45	52	53	57	61	74	78	78	1.0	1.0	0.430	0.05
61.900	60.700	13,916	13,646	7,500	8,900	52	53	57	61	-	78	-	78	1.0	1.0	0.450	0.05
61.900	60.700	13,916	13,646	7,500	8,900	52	53	57	61	74	78	78	1.0	1.0	0.425	0.05	
76.400	79.400	17,175	17,850	7,100	8,400	52	53	57	61	-	78	-	78	1.0	1.0	0.550	-
76.400	79.400	17,175	17,850	7,100	8,400	53	53	57	61	-	76	-	76	1.5	1.0	0.520	-
89.100	117.700	20,031	26,460	6,700	7,900	53	-	57	-	-	76	-	76	1.5	1.0	0.797	-
70.800	61.900	15,917	13,916	6,300	7,500	52	56	60	66	84	91	90	1.5	1.5	0.870	0.10	
102.000	98.000	22,931	22,031	6,000	7,100	52	56	60	66	-	91	-	91	1.5	1.5	0.890	0.10
139.000	147.000	31,249	33,047	5,600	6,700	52	56	60	66	-	91	-	91	1.5	1.5	1.360	-
104.000	90.900	23,380	20,435	5,300	6,300	55	62.7	66	75	99	107	103	2.0	2.0	1.650	0.18	
46.400	44.700	10,431	10,049	7,100	8,400	57	58	62	67	78	83	83	1.0	1.0	0.480	0.06	
64.300	65.600	14,455	14,748	6,700	7,900	50	57	57	61	66	-	83	-	1.0	1.0	0.490	0.06
66.200	72.200	14,882	16,231	7,100	8,400	57	57	61	66	-	83	-	83	1.0	1.0	0.580	-
63.100	66.800	14,186	15,017	7,100	8,400	57	58	62	66	-	83	-	83	1.0	1.0	0.580	-
84.100	90.900	18,907	20,435	6,700	7,900	57	57	61	66	-	83	-	83	1.0	1.0	0.590	-
92.600	128.000	20,817	28,776	6,300	7,500	58	-	62	-	-	81	-	81	1.5	1.0	0.877	-
87.400	79.400	19,648	17,850	5,600	6,700	60	63	67	74	93	100	99	2.0	2.0	1.150	0.15	
117.000	114.000	26,303	25,628	5,300	6,300	60	63	67	74	95	100	100	2.0	2.0	1.130	0.14	
123.000	126.000	27,652	28,326	5,600	6,700	60	63	67	74	-	100	-	100	2.0	2.0	0.170	-
168.000	178.000	37,768	40,016	5,000	6,000	60	63	67	74	-	100	-	100	2.0	2.0	1.830	-
139.000	114.000	31,249	25,628	4,700	5,600	63	68	73	82	109	116	114	2.0	2.0	2.000	0.23	
56.200	56.200	12,634	12,634	6,300	7,500	55	62	65	68	73	86	91	91	1.5	1.0	0.640	0.08
85.800	90.900	19,289	20,435	6,300	7,500	62	64.5	68	73	-	91	-	91	1.5	1.0	0.660	0.08
98.000	116.000	22,031	26,078	5,600	6,700	62	65	68	73	-	91	-	91	1.5	1.0	0.810	-
76.400	82.500	17,175	18,547	6,300	7,500	62	65	68	73	-	91	-	91	1.5	1.0	0.780	-
119.000	171.000	26,752	38,443	5,600	6,700	64	-	69	-	-	90	-	90	2.0	1.5	1.200	-
108.000	100.000	24,279	22,481	5,300	6,300	65	67	72	80	102	110	108	2.0	2.0	1.450	0.19	
136.000	128.000	30,574	28,776	4,700	5,600	65	67	72	80	-	110	-	110	2.0	2.0	1.380	0.18
137.000	142.000	30,799	31,923	4,700	5,600	65	67	72	80	-	110	-	110	2.0	2.0	1.900	-
139.000	128.000	31,249	28,776	4,500	5,300	68	71	79	88	115	126	120	2.0	2.0	2.500	0.30	
66.800	68.100	15,017	15,310	5,600	6,700	60	67	71	75	80	95	101	101	1.5	1.5	0.820	0.11
98.000	108.000	22,031	24,279	5,600	6,700	67	71	75	80	95	101	101	101	1.5	1.5	0.880	-
104.000	108.000	23,380	24,279	5,600	6,700	67	71	75	80	95	101	101	101	1.5	1.5	0.950	-
133.000	161.000	29,900	36,194	5,300	6,300	69	69.5	74	79	-	101	-	101	1.5	1.5	1.170	-
98.100	112.000	22,054	25,179	5,600	6,700	69	69.5	74	79	-	101	-	101	1.5	1.5	1.050	-
150.000	211.000	33,722	47,435	5,300	6,300	69	-	74	-	-	99	-	99	2.0	1.5	1.590	-
121.000	114.000	27,202	25,628	4,700	5,600	72	75	79	87	110	118	117	2.0	2.0	1.850	0.22	
168.000	174.000	37,768	39,117	4,700	5,600	72	75	79	87	-	118	-	118	2.0	2.0	2.700	-
168.000	158.000	37,768	35,520	4,200	5,000	73	77	85	95	124	136	130	2.0	2.0	3.000	0.34	

Single Row Cylindrical Roller Bearings

d = 65 to 80 mm

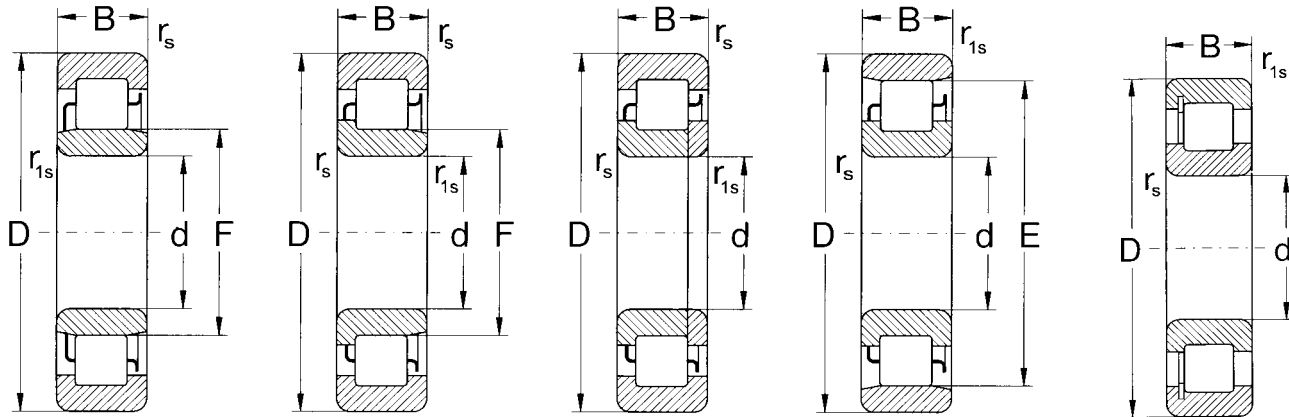

NU

NJ

NUP

N

NFD

NU + HJ = NUJ

NJ + HJ = NH

F

Dimension											Bearing Designation				Angle Ring
d	D	B	r _s min	r _{1s} min	F	E	d ₂ max	b	b _t	s ¹⁾	NU / NUJ	NJ / NH	NUP	N / NFD	HJ
mm															
65	120	23.00	1.5	1.5	79.600	105.6	85.6	6	11.00	1.6	NU213	NJ213	NUP213	N213	HJ213
120	23.00	1.5	1.5	78.500	-	-	-	-	-	1.6	NU213E	NJ213E	-	-	-
120	31.00	1.5	1.5	79.600	-	-	-	-	-	1.6	NU2213	NJ2213	NUP2213	-	-
120	31.00	1.5	1.5	79.600	-	-	-	-	-	1.6	NU2213E	NJ2213E	-	-	-
120	38.10	1.7	1.7	80.420	-	-	-	-	-	4.5	NU5213M	-	-	-	-
140	33.00	2.1	2.1	83.500	121.5	92.2	10	17.00	1.5	NU313	NJ313	NUP313	N313	HJ313	
140	33.00	2.1	2.1	82.500	-	90.7	10	15.50	1.5	NU313E	NJ313E	NUP313E	-	HJ313E	
140	33.00	2.1	2.1	82.500	124.5	-	-	-	-	1.5	NU313EM	NJ313EM	-	N313EM	-
140	48.00	2.1	2.1	83.500	-	-	-	-	-	4.5	NU2313	NJ2313	NUP2313	-	-
140	48.00	2.1	2.1	82.500	-	-	-	-	-	4.5	NU2313E	NJ2313E	-	-	-
160	37.00	2.1	2.1	89.300	-	99.9	11	18.00	2.0	NU413MAS	NJ413MAS	NUP413MAS	-	HJ413	
70	125	24.00	1.5	1.5	84.500	110.5	90.5	7	12.50	1.6	NU214	NJ214	NUP214	N214	HJ214
125	31.00	1.5	1.5	84.500	-	-	-	-	-	1.6	NU2214	NJ2214	NUP2214	-	-
125	31.00	1.5	1.5	83.500	113.5	-	-	-	-	1.6	NU2214ETNG	NJ2214ETNG	-	-	-
125	39.69	1.5	2.2	84.840	-	-	-	-	-	4.5	NU5214M	-	-	-	-
150	35.00	2.1	2.1	90.000	130.0	99.2	10	17.50	1.5	NU314	NJ314	NUP314	N314	HJ314	
150	51.00	2.1	2.1	90.000	-	-	-	-	-	4.1	NU2314	NJ2314	NUP2314	-	-
150	51.00	2.1	2.1	89.000	-	-	-	-	-	4.1	NU2314EMAS	NJ2314EMAS	NUP2314EMAS	-	-
180	42.00	3.0	3.0	100.000	152.0	112.0	12	20.00	2.0	NU414	NJ414	NUP414	N414	HJ414	
75	130	25.00	1.5	1.5	88.500	116.5	94.9	7	12.50	1.6	NU215	NJ215	NUP215	N215	HJ215
130	25.00	1.5	1.5	88.500	-	94.6	7	11.00	1.6	NU215E	NJ215E	NUP215E	-	HJ215E	
130	25.00	1.5	1.5	88.500	-	-	-	-	-	1.6	NU215ETNG	NJ215ETNG	-	-	-
130	31.00	1.5	1.5	88.500	-	-	-	-	-	2.1	NU2215E	NJ2215E	NUP2215	-	-
130	31.00	1.5	1.5	88.500	118.5	-	-	-	-	2.1	NU2215ETNG	NJ2215ETNG	-	-	-
130	41.28	1.5	1.5	89.014	-	-	-	-	-	4.5	NU5215M	-	-	-	-
160	37.00	2.1	2.1	95.500	139.5	105.6	11	18.50	1.5	NU315	NJ315	NUP315	N315	HJ315	
160	37.00	2.1	2.1	95.000	143.0	-	-	-	-	1.5	NU315ETNG	NJ315ETNG	-	-	-
160	37.00	2.1	2.1	95.000	143.0	-	-	-	-	1.5	NU315EM	NJ315EM	-	N315EM	-
160	37.00	2.1	2.1	95.000	-	-	-	-	-	1.5	NU315EMA	NJ315EMA	-	-	-
160	55.00	2.1	2.1	95.500	-	-	-	-	-	4.5	NU2315	NJ2315	NUP2315	-	-
190	45.00	3.0	2.0	104.500	160.5	117.0	13	21.50	2.0	NU415	NJ415	NUP415	N415	HJ415	
80	125	22.00	1.1	1.0	91.500	-	-	-	-	1.2	NU1016M	-	-	-	-
140	26.00	2.0	2.0	95.300	125.3	102.2	8	13.50	2.0	NU216	NJ216	NUP216	N216	HJ216	
140	26.00	2.0	2.0	95.300	-	-	-	-	-	1.7	NU216E	NJ216E	-	-	-
140	26.00	2.0	2.0	95.300	127.3	-	-	-	-	1.7	-	-	-	N216EM	-
140	33.00	2.0	2.0	95.300	-	-	-	-	-	2.5	NU2216	NJ2216	NUP2216	-	-
140	33.00	2.0	2.0	95.300	-	-	-	-	-	2.5	NU2216E	NJ2216E	NUP2216E	-	-
140	44.45	2.1	2.1	95.280	-	-	-	-	-	5.0	NU5216M	-	-	-	-
170	39.00	2.1	2.1	103.000	147.0	113.1	11	19.50	1.5	NU316	NJ316	NUP316	N316	HJ316	
170	39.00	2.1	2.1	101.000	-	-	-	-	-	0.6	NU316E	NJ316E	-	-	-
170	39.00	2.1	2.1	101.000	151.0	-	-	-	-	0.6	NU316EM	NJ316EM	-	N316EM	-
170	39.00	2.1	2.1	101.000	-	-	-	-	-	0.6	NU316EMA	NJ316EMA	-	-	-
170	58.00	2.1	2.1	103.000	-	-	-	-	-	4.5	NU2316	NJ2316	-	-	-
170	58.00	2.1	2.1	103.000	-	-	-	-	-	4.5	NU2316M	NJ2316M	-	-	-
200	48.00	3.0	3.0	110.000	170.0	123.8	13	22.00	2.0	NU416M	NJ416M	NUP416M	N416M	HJ416	

¹⁾ Permissible axial displacement out of central position

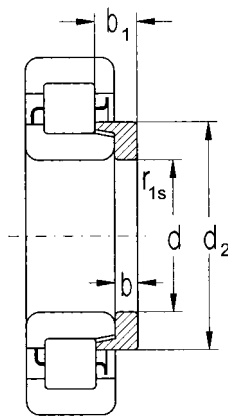

HJ

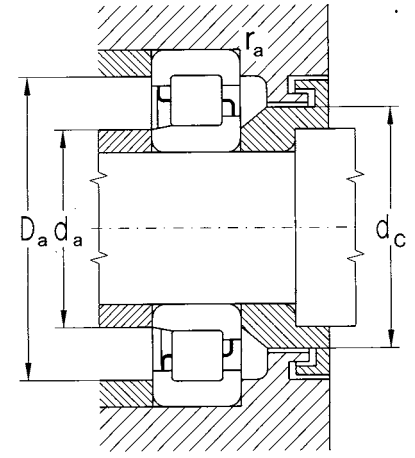
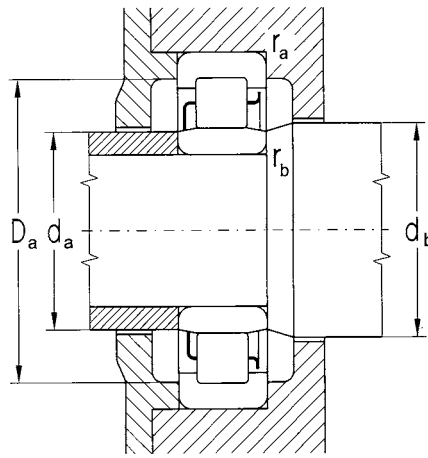

F

Basic Load Rating				Limiting Speed for Lubrication with		Abutment and Fillet Dimensions										Weight	
Dynamic C _r	Static C _{0r}	Dynamic C _r	Static C _{0r}	Grease	Oil	d	d _a min	d _a max	d _b min	d _c min	d _d max	D _a max	D _b min	r _a max	r _b max	Bearing	Angle Ring
kN	kN	lbs.	lbs.	rpm		mm										kg	
79.4	82.5	17,850	18,547	5,300	6,300	65	72	77	81	87	103	111	110	1.5	1.5	1.05	0.13
113.0	127.0	25,404	28,551	5,000	6,000	72	76	80	86	106	111	111	1.5	1.5	1.10	-	
117.0	136.0	26,303	30,574	5,300	6,300	72	77	81	87	-	111	-	1.5	1.5	1.45	-	
149.0	180.0	33,497	40,466	4,700	5,600	72	76	80	86	-	111	-	1.5	1.5	1.50	-	
139.0	196.0	31,249	44,063	4,700	5,600	77	-	83	-	-	108	-	1.5	1.5	1.88	-	
131.0	128.0	29,450	28,776	4,500	5,300	76	78	85	94	119	128	126	2.0	2.0	2.25	0.29	
181.0	178.0	40,691	40,016	4,200	5,000	76	77	84	93	-	128	-	2.0	2.0	2.35	0.27	
180.0	191.0	40,466	42,939	4,000	4,700	76	77	84	93	122	128	128	2.0	2.0	2.66	-	
192.0	203.0	43,164	45,636	4,500	5,300	76	78	85	94	-	128	-	2.0	2.0	3.25	-	
247.0	287.0	55,528	64,520	4,000	4,700	76	77	84	93	-	128	-	2.0	2.0	3.46	-	
181.0	174.0	40,691	39,117	3,800	4,500	78	83	91	101	-	146	-	2.0	2.0	3.60	0.43	
79.4	82.5	17,850	18,547	5,600	6,700	70	77	82	86	92	108	116	115	1.5	1.5	1.15	0.16
117.0	139.0	26,303	31,249	5,000	6,000	77	82	86	92	-	116	-	1.5	1.5	1.50	-	
162.0	205.0	36,419	46,086	4,500	5,300	77	82	86	92	-	116	-	1.5	1.5	1.53	-	
178.0	261.0	40,016	58,675	4,700	5,600	81.5	-	87	-	-	112	-	2.0	1.5	2.22	-	
147.0	144.0	33,047	32,373	4,200	5,000	81	85	92	101	127	138	135	2.0	2.0	2.75	0.34	
215.0	233.0	48,334	52,381	4,200	5,000	81	85	92	101	-	138	-	2.0	2.0	5.25	-	
282.0	310.0	63,396	69,691	3,800	4,500	81	84	91	100	-	138	-	2.0	2.0	4.21	-	
224.0	215.0	50,357	48,334	3,300	4,000	85	93	102	114	149	164	156	2.5	2.5	5.25	0.61	
96.2	96.2	21,627	21,627	4,700	5,600	75	82	85	90	96	114	121	120	1.5	1.5	1.25	0.17
131.0	147.0	29,450	33,047	4,500	5,300	82	85	90	96	-	121	-	1.5	1.5	1.30	0.16	
135.0	165.0	30,349	37,094	4,500	5,300	82	85	90	96	-	121	-	1.5	1.5	1.25	-	
162.0	196.0	36,419	44,063	4,500	5,300	82	85	90	96	-	121	-	1.5	1.5	1.65	-	
168.0	218.0	37,768	49,009	4,500	5,300	82	85	90	96	-	121	-	1.5	1.5	1.62	-	
196.0	299.0	44,063	67,218	4,500	5,300	85.5	-	91	-	-	117	-	2.0	1.5	2.41	-	
178.0	178.0	40,016	40,016	3,800	4,500	86	93	97	107	137	148	145	2.0	2.0	3.25	0.40	
254.0	283.0	57,102	63,621	3,500	4,200	86	93	97	107	137	148	145	2.0	2.0	4.20	-	
240.0	263.0	53,954	59,125	3,500	4,200	86	93	97	107	137	148	145	2.0	2.0	3.80	-	
240.0	263.0	53,954	59,125	3,500	4,200	86	93	97	107	137	148	145	2.0	2.0	3.80	-	
266.0	287.0	59,799	64,520	3,800	4,500	86	93	97	107	-	148	-	2.0	2.0	4.85	-	
261.0	251.0	58,675	56,427	3,200	3,800	90	98	107	119	158	174	164	2.5	2.5	6.25	0.80	
66.8	76.4	15,017	17,175	5,000	6,000	80	85	90	94	-	118	-	1.0	1.0	0.99	-	
106.0	114.0	23,830	25,628	4,500	5,300	90	92	97	104	125	130	130	2.0	2.0	1.50	0.21	
139.0	167.0	31,248	37,543	4,200	5,000	90	92	97	104	125	130	130	2.0	2.0	1.64	-	
139.0	167.0	31,248	37,543	4,200	5,000	90	92	97	104	125	130	130	2.0	2.0	1.81	-	
147.0	178.0	33,047	40,016	4,500	5,300	90	92	97	104	-	130	-	2.0	2.0	1.95	-	
196.0	246.0	44,063	55,303	4,200	5,000	90	92	97	104	-	130	-	2.0	2.0	2.05	-	
185.0	282.0	41,590	63,396	4,200	5,000	91.5	-	98	-	-	126	-	2.0	2.0	2.91	-	
192.0	192.0	43,163	43,163	3,500	4,200	99	97	105	116	144	158	153	2.0	2.0	3.90	0.49	
251.0	275.0	56,427	61,822	3,300	4,000	99	97	105	116	144	158	153	2.0	2.0	4.10	-	
251.0	275.0	56,427	61,822	3,300	4,000	99	97	105	116	144	158	153	2.0	2.0	4.58	-	
251.0	275.0	56,427	61,822	3,300	4,000	99	97	105	116	144	158	153	2.0	2.0	4.58	-	
274.0	331.0	61,598	74,412	3,500	4,200	91	99	105	116	-	158	-	2.0	2.0	6.04	-	
274.0	331.0	61,598	74,412	3,500	4,200	91	99	105	116	-	158	-	2.0	2.0	6.50	-	
299.0	293.0	67,218	65,869	3,000	3,500	95	105	112	125	167	184	174	2.5	2.5	7.30	0.80	

Single Row Cylindrical Roller Bearings

d = 85 to 105 mm

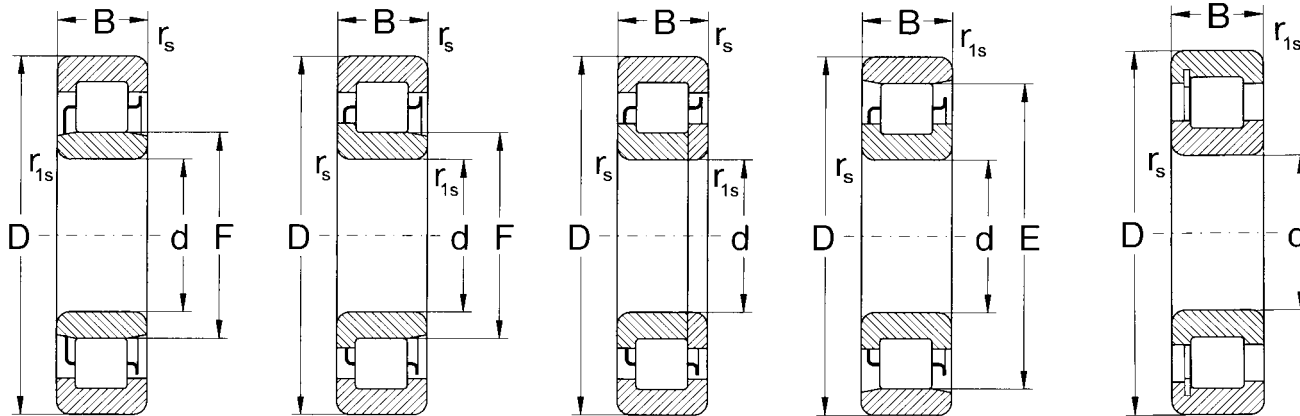

NU

NJ

NUP

N

NFD

NU + HJ = NUJ

NJ + HJ = NH

Dimension											Bearing Designation				Angle Ring
d	D	B	r _s min	r _{1s} min	F	E	d ₂ max	b	b ₁	s ¹⁾	NU / NUJ	NJ / NH	NUP	N / NFD	HJ
mm															
85	130	22.0	1.1	1.1	96.500	-	-	-	-	2.0	NU1017M				
	150	28.0	2.0	2.0	101.800	133.8	109.2	8	14.00	2.0	NU217	NJ217	NUP217	N217	HJ217
	150	28.0	2.0	2.0	-	-	-	-	-	2.0			NUP217ETNG		
	150	36.0	2.0	2.0	100.500	-	-	-	-	2.0	NU2217E	NJ2217E	NUP2217E		
	150	49.21	2.1	2.1	102.000	-	-	-	-	5.5	NU5217M				
	180	41.0	3.0	3.0	108.000	156.0	119.0	12	20.50	2.0	NJ317	NJ317	NUP317	N317	HJ317
	180	41.0	3.0	3.0	108.000	160.0	-	-	-	2.0	NU317EM	NJ317EM		N317EM	
	180	41.0	3.0	3.0	108.000	-	-	-	-	2.0	NU317EMA	NJ317EMA			
	180	41.0	3.0	3.0	108.000	-	-	-	-	2.0	NU317E	NJ317E			
	210	52.0	4.0	4.0	113.000	-	127.7	14	24.00	2.5	NU417M	NJ417M	NUP417M		HJ417
90	160	30.0	2.0	2.0	107.000	143.0	115.3	9	15.00	2.0	NU218	NJ218	NUP218	N218	HJ218
	160	30.0	2.0	2.0	107.000	-	-	-	-	2.0	NU218E	NJ218E			
	160	40.0	2.1	2.1	107.000	-	-	-	-	2.5	NU2218				
	160	52.4	2.1	3.0	107.218	-	-	-	-	6.0	NU5218M				
	190	43.0	3.0	3.0	115.000	165.0	126.5	12	21.00	2.0	NU318	NJ318	NUP318	N318	HJ318
	190	43.0	3.0	3.0	113.500	-	124.2	12	18.50	2.0	NU318E	NJ318E	NUP318E		HJ318E
	190	64.0	3.0	3.0	113.500	-	-	-	-	3.8	NU2318EMAS	NJ2318EMAS	NUP2318EMAS		
	225	54.0	4.0	4.0	123.500	-	139.1	14	24.00	2.5	NU418M	NJ418M	NUP418M		HJ418
	225	54.0	4.0	4.0	123.500	-	139.1	14	24.00	2.5	NU418MAS	NJ418MAS	NUP418MAS		HJ418
95	170	32.0	2.1	2.1	113.500	151.5	122.2	9	15.50	2.0	NU219	NJ219	NUP219	N219	HJ219
	170	32.0	2.1	2.1	112.500	-	-	-	-	2.0	NU219E	NJ219E			
	170	43.0	2.1	2.1	113.500	-	-	-	-	3.0	NU2219	NJ2219	NUP2219		
	170	43.0	2.1	2.1	112.500	-	-	-	-	3.0	NU2219E	NJ2219E			
	170	55.56	2.5	3.0	113.520	-	-	-	-	6.0	NU5219M				
	200	45.0	3.0	3.0	121.500	173.5	-	-	-	2.0	NU319	NJ319	NUP319	N319	
	200	45.0	3.0	3.0	121.500	-	-	-	-	1.9	NU319EM	NJ319EM	NUP319EM		
	200	45.0	3.0	3.0	121.500	-	-	-	-	1.9	NU319E	NJ319E			
	240	55.0	4.0	4.0	133.500	-	-	-	-	2.5	NU419M	NJ419M	NUP419M		
100	180	34.0	2.1	2.1	120.000	160.0	129.2	10	17.00	2.0	NU220	NJ220	NUP220	N220	HJ220
	180	46.0	2.1	2.1	120.000	-	-	-	-	3.0	NU2220	NJ2220	NUP2220		
	180	60.32	2.1	2.1	121.005	-	-	-	-	7.0	NU5220M				
	215	47.0	3.0	3.0	129.500	185.5	142.4	13	22.50	2.0	NU320	NJ320	NUP320	N320	HJ320
	215	73.0	3.0	3.0	127.500	-	-	-	-	4.9	NU2320EMAS	NJ2320EMAS	NUP2320EMAS		
	250	58.0	4.0	4.0	139.000	-	155.9	16	27.00	2.5	NU420M	NJ420M	NUP420M		HJ420
105	190	36.0	2.1	2.1	126.800	168.8	136.5	10	17.50	2.0	NU221	NJ221	NUP221	N221	HJ221
	190	36.0	2.1	2.1	126.000	174.0	-	-	-	2.0	NU221ETNG	NJ221ETNG			
	190	65.1	2.1	2.1	126.520	-	-	-	-	7.0	NU5221M				
	225	49.0	3.0	3.0	135.000	195.0	148.8	13	22.50	4.5	NU321	NJ321	NUP321	N321	HJ321
	260	60.0	4.0	4.0	144.500	-	162.0	16	27.00	2.5	NU421M	NJ421M	NUP421M		HJ421

¹⁾ Permissible axial displacement out of central position

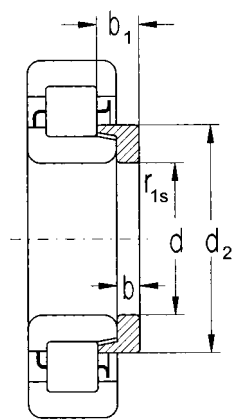

HJ

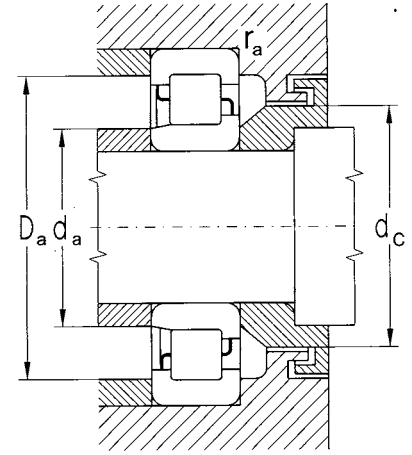
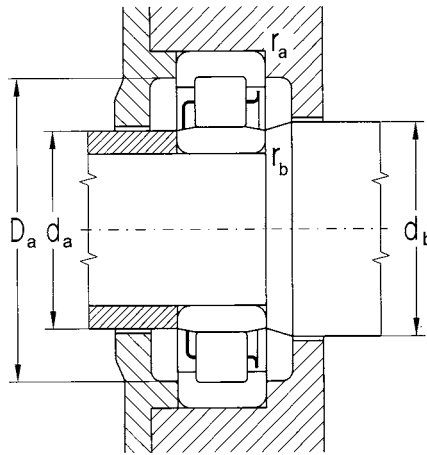

F

Basic Load Rating				Limiting Speed for Lubrication with		Abutment and Fillet Dimensions										Weight	
Dynamic C_r	Static C_{rr}	Dynamic C_r	Static C_{rr}	Grease	Oil	d	d_a min	d_a max	d_b min	d_c min	d_j max	D_a max	D_b min	r_a max	r_b max	Bearing	Angle Ring
kN	kN	lbs.	lbs.	rpm		mm										kg	
71	89	15,962	20,008	4,700	5,600	85	90	95	99	-	-	123	-	1.0	1.0	1.05	-
121	131	27,202	29,450	4,200	5,000	95	95	99	104	111	131	140	138	2.0	2.0	1.90	0.25
171	205	38,442	46,086	4,000	4,700	95	99	104	111	131	140	138	2.0	2.0	2.14	-	
220	261	49,458	58,675	3,800	4,500	95	98	103	110	-	140	-	2.0	2.0	2.52	-	
211	316	47,435	71,040	3,800	4,500	98	-	105	-	-	135	-	2.0	2.0	3.69	-	
215	215	48,334	48,334	3,300	4,000	98	103	110	121	174	166	162	2.5	2.5	4.50	0.57	
285	322	64,071	72,389	3,200	3,800	98	103	110	121	174	166	162	2.5	2.5	5.35	-	
285	322	64,071	72,389	3,200	3,800	98	103	110	121	174	166	162	2.5	2.5	5.35	-	
286	322	64,296	72,389	3,200	3,800	98	103	110	121	178	166	166	2.5	2.5	4.87	-	
362	362	81,381	81,381	3,000	3,500	105	108	115	129	-	190	-	3.0	3.0	8.70	0.89	
147	158	33,047	35,520	4,000	4,700	90	100	105	109	117	140	150	147	2.0	2.0	2.30	0.31
182	217	40,915	48,784	3,800	4,500	100	100	105	109	117	142	150	149	2.0	2.0	2.48	-
204	260	45,861	58,450	3,500	4,200	100	100	105	109	117	-	150	-	2.0	2.0	3.30	-
237	355	53,280	79,808	3,500	4,200	103	-	110	-	-	144	-	2.5	2.0	4.48	-	
233	242	52,381	54,404	3,200	3,800	103	111	117	128	162	176	172	2.5	2.5	5.40	0.65	
316	329	71,040	73,962	3,000	3,500	103	110	116	127	-	176	-	2.5	2.5	5.50	0.60	
430	526	100,490	114,878	2,800	3,300	103	111	117	128	-	176	-	2.5	2.5	8.20	-	
391	406	87,901	91,273	2,700	3,200	110	117	125	140	-	205	-	3.0	3.0	11.70	1.05	
391	406	87,901	91,273	2,700	3,200	110	117	125	140	-	205	-	3.0	3.0	11.70	1.05	
162	181	36,419	40,691	3,800	4,500	95	107	111	116	124	149	158	155	2.0	2.0	2.80	0.35
220	264	49,458	59,350	3,500	4,200	107	107	110	115	123	152	158	158	2.0	2.0	3.01	-
233	282	52,381	63,396	3,800	4,500	107	111	116	124	-	158	-	2.0	2.0	3.85	-	
286	370	64,295	83,179	3,300	4,000	107	111	116	124	-	158	-	2.0	2.0	4.05	-	
335	511	75,311	114,878	3,300	4,000	110	-	117	-	-	153	-	2.5	2.0	5.65	-	
256	266	57,511	59,799	3,200	3,800	109	119	124	135	170	186	178	2.5	2.5	6.20	-	
329	362	73,962	81,381	2,800	3,300	109	119	124	135	-	186	-	2.5	2.5	6.50	-	
329	378	73,962	84,978	2,800	3,300	109	119	124	135	-	186	-	2.5	2.5	6.52	-	
430	447	96,668	100,490	2,500	3,000	115	125	136	151	-	220	-	3.0	3.0	13.50	-	
178	203	40,016	45,636	3,500	4,200	100	112	117	122	131	157	168	165	2.0	2.0	3.40	0.45
261	322	58,675	72,389	3,500	4,200	112	117	122	131	-	168	-	2.0	2.0	4.65	-	
304	473	68,342	106,335	3,200	3,800	116.5	-	124	-	-	162	-	2.0	2.0	6.49	-	
299	310	67,218	69,691	2,800	3,300	113	125	132	145	182	201	190	2.0	2.0	7.70	0.91	
596	694	133,987	156,018	2,500	3,000	113	123	130	144	-	201	-	2.5	2.5	12.50	-	
473	501	106,335	112,630	2,400	2,800	120	130	141	158	-	230	-	3.0	3.0	14.00	1.55	
200	224	44,962	50,357	3,300	4,000	105	117	122	129	138	166	178	175	2.0	2.0	4.00	0.51
286	351	64,296	78,908	3,100	3,800	117	122	129	138	166	178	175	2.0	2.0	4.17	-	
362	573	81,381	128,816	3,000	3,500	121.5	-	130	-	-	171	-	2.0	2.0	7.94	-	
341	362	76,660	81,381	2,700	3,200	119	132	137	150	192	211	199	2.5	2.5	8.75	1.00	
531	562	119,374	126,343	2,200	2,700	125	135	147	164	-	240	-	3.0	3.0	19.00	1.65	

Single Row Cylindrical Roller Bearings

d = 110 to 150 mm

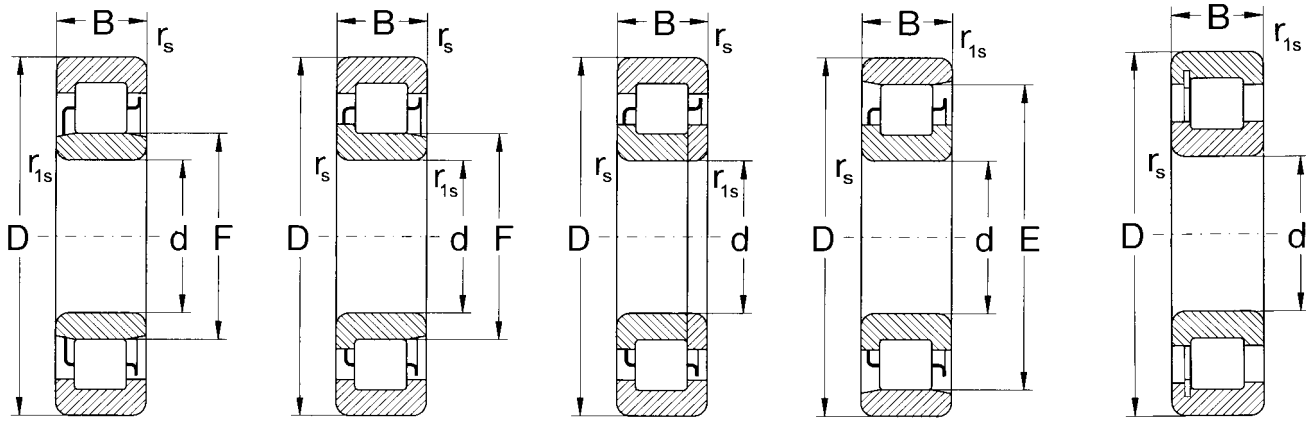

NU

NJ

NUP

N

NFD

NU + HJ = NUJ

NJ + HJ = NH

Dimension											Bearing Designation				Angle Ring
d	D	B	r _s min	r _{1s} min	F	E	d ₂ max	b	b ₁	s ¹⁾	NU / NUJ	NJ / NH	NUP	N / NFD	HJ
mm															
110	200	38.0	2.1	2.1	132.500	178.5	143.1	11	18.50	2.5	NU222	NJ222	NUP222	N222	HJ222
	200	53.0	2.1	2.1	132.500	-	-	-	-	5.0	NU2222	NJ2222	NUP2222		
	200	69.85	2.1	4.0	132.951	-	-	-	-	7.0	NU5222M				
	240	50.0	3.0	3.0	143.000	207.0	157.5	14	23.00	2.7	NU322	NJ322	NUP322	N322	HJ322
	240	50.0	3.0	3.0	143.000	-	-	-	-	2.9	NU322EM	NJ322EM	NUP322EM		
	280	65.0	4.0	4.0	155.000	-	173.4	17	29.50	2.7	NU422M	NJ422M	NUP422		HJ422
120	180	28.0	2.0	1.1	135.000	-	-	-	-	2.0	NU1024M				
	215	40.0	2.1	2.1	143.500	191.5	154.5	11	19.00	2.5	NU224	NJ224	NUP224	N224	HJ224
	215	58.0	2.1	2.1	143.500	-	-	-	-	5.4	NU2224	NJ2224	NUP2224		
	215	76.2	2.1	2.1	145.140	-	-	-	-	7.0	NU5224M				
	260	55.0	3.0	3.0	154.000	-	170.5	14	23.50	2.7	NU324	NJ324	NUP324		HJ324
	260	86.0	3.0	3.0	154.000	-	-	-	-	6.4	NU2324EMAS	NJ2324EMAS	NUP2324EMAS		
	310	72.0	5.0	6.0	170.000	-	188.0	17	30.50	2.7	NU424	NJ424M	NUP424M		HJ424
130	200	33.0	2.0	1.1	148.000	-	-	-	-	2.0	NU1026M				
	230	40.0	3.0	3.0	156.000	204.0	167.0	11	19.00	2.5	NU226	NJ226	NUP226	N226	HJ226
	230	79.38	4.0	4.0	155.000	-	-	-	-	8.0	NU5226M				
	280	58.0	4.0	4.0	167.000	-	182.3	14	23.00	2.9	NU326EM	NJ326EM	NUP326EM		HJ326E
	280	58.0	4.0	4.0	167.000	-	182.3	14	23.00	2.9	NU326EM	NJ326EM	NUP326EM		HJ326E
140	250	42.0	3.0	3.0	169.000	221.0	181.0	11	19.00	2.5	NU228	NJ228	NUP228	N228	HJ228
	250	82.55	4.0	4.0	168.460	-	-	-	-	10.0	NU5228M				
	300	62.0	4.0	4.0	180.000	-	198.4	15	26.00	2.7	NU328M	NJ328M	NUP328M		HJ328
	300	62.0	4.0	4.0	180.000	-	-	-	-	9.2	NU2328M	NJ2328M	NUP2328M		
150	225	35.0	2.1	1.5	169.500	-	-	-	-	2.0	NU1030M				
	270	45.0	3.0	3.0	182.000	-	194.7	12	20.50	2.4	NU230	NJ230	NUP230		HJ230
	270	45.0	3.0	3.0	182.000	-	193.7	12	19.50	2.4	NU230EM	NJ230EM	NUP230EM		HJ230E
	270	88.9	2.3	2.3	181.544	-	-	-	-	10.0	NU5230M				
	320	65.0	4.0	4.0	193.000	-	212.3	15	26.50	2.7	NU330M	NJ330M	NUP330M		HJ330

¹⁾ Permissible axial displacement out of central position

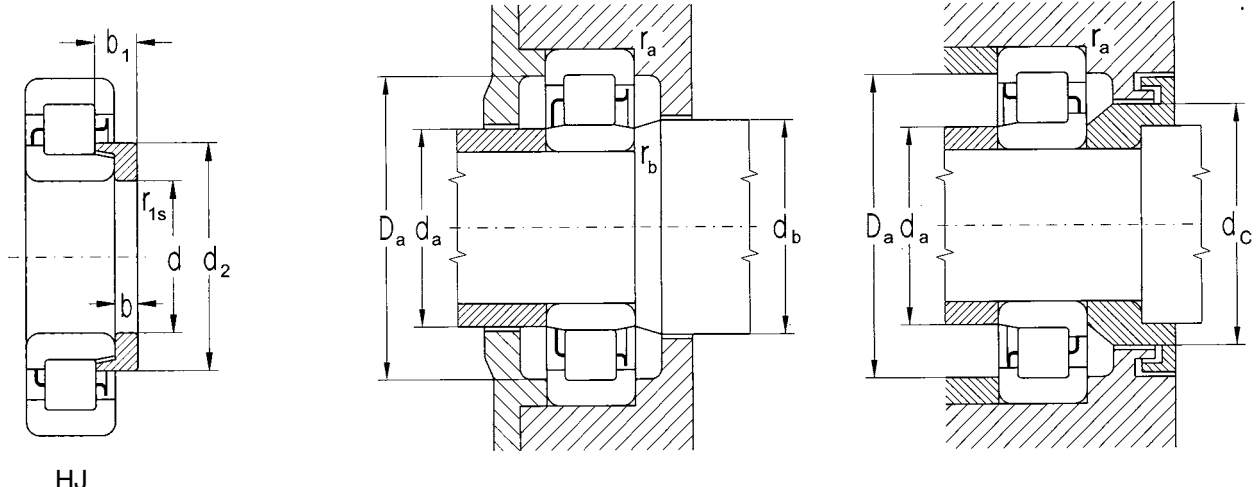

HJ

F

Basic Load Rating				Limiting Speed for Lubrication with		Abutment and Fillet Dimensions										Weight	
Dynamic C_r	Static C_{or}	Dynamic C_r	Static C_{or}	Grease	Oil	d	d_a	d_b	d_b	d_c	d_d	D_a	D_b	r_a	r_b	Bearing	Angle Ring
kN	kN	lbs.	lbs.	rpm		mm										kg	
237	271	53,280	60,924	3,200	3,800	110	122	125	135	145	175	188	182	2.0	2.0	4.65	0.62
341	422	76,660	94,870	3,200	3,800	122	125	135	145	-	188	-	2.0	2.0	6.95	-	
464	736	104,312	165,460	3,000	3,500	128	-	137	-	-	180	-	3.0	2.0	10.00	-	
391	414	87,901	93,071	2,500	3,000	124	135	145	160	204	226	211	2.5	2.5	10.50	1.17	
447	492	100,490	110,607	2,400	2,800	124	135	145	160	-	226	-	2.5	2.5	11.00	-	
584	631	131,289	141,855	2,100	2,500	130	140	157	175	-	260	-	3.0	3.0	20.00	2.16	
131	168	29,450	37,768	3,300	4,000	120	128	131	138	-	171	-	2.0	1.0	2.45	-	
261	299	58,675	67,218	3,000	3,500	132	138	146	157	188	203	196	2.0	2.0	5.65	0.72	
369	473	82,955	106,335	3,000	3,500	132	138	146	157	-	203	-	2.0	2.0	8.55	-	
482	794	108,358	178,499	2,700	3,200	140	-	149	-	-	194	-	2.0	2.0	11.80	-	
447	473	100,490	106,335	2,400	2,800	134	145	156	172	-	246	-	2.5	2.5	13.00	1.40	
810	981	182,096	220,539	2,100	2,500	134	145	156	172	-	246	-	2.5	2.5	24.50	-	
736	810	165,460	182,096	1,900	2,200	144	155	172	192	-	286	-	4.0	4.0	28.00	2.60	
162	203	36,419	45,636	3,200	3,800	130	138	143	151	-	191	-	2.0	1.0	3.75	-	
271	322	60,924	72,389	2,700	3,200	144	150	158	169	201	216	208	2.5	2.5	6.50	0.84	
511	841	114,878	189,065	2,500	3,000	149	-	159	-	-	207	-	3.0	2.0	13.80	-	
619	694	139,157	156,018	2,000	2,400	148	155	169	186	-	262	-	3.0	3.0	17.00	1.65	
310	369	69,691	82,955	2,500	3,000	140	154	160	171	182	218	236	2.5	2.5	8.25	1.00	
596	981	133,987	220,539	2,200	2,700	162	-	173	-	-	225	-	3.0	3.0	17.10	-	
619	708	139,157	159,165	2,000	2,400	158	166	182	198	-	282	-	3.0	3.0	20.00	2.05	
909	1,229	204,352	276,291	2,000	2,400	158	166	182	198	-	282	-	3.0	3.0	36.70	-	
192	251	43,164	56,427	2,700	3,200	150	159	165	173	-	213	-	2.0	1.5	4.85	-	
369	455	82,955	102,289	2,200	2,700	164	170	184	196	-	256	-	2.5	2.5	10.50	1.35	
447	552	100,490	124,095	2,200	2,700	164	170	184	196	-	256	-	2.5	2.5	11.00	1.30	
736	1,260	165,460	283,261	2,000	2,400	174	-	187	-	-	243	-	5.0	2.0	22.90	-	
681	779	153,096	175,127	1,900	2,200	168	185	195	213	-	302	-	3.0	3.0	27.00	2.37	

Single Row Cylindrical Roller Bearings

d = 160 to 1180 mm

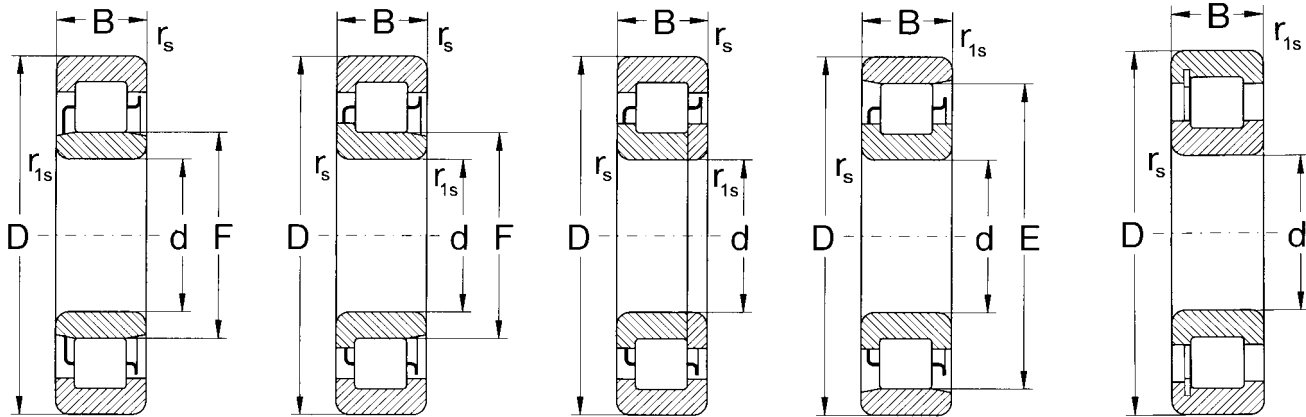

NU

NJ

NUP

N

NFD

NU + HJ = NUJ

NJ + HJ = NH

F

Dimension										Bearing Designation				Angle Ring
d	D	B	r _s min	r _{1s} min	F	d ₂ max	b	b ₁	s ¹⁾	NU / NUJ	NJ / NH	NUP	N / NFD	HJ
mm														
160	290	48.0	3.00	3.0	195.000	207.4	12	20.00	2.5	NU232EM	NJ232EM	NUP232EM		HJ232E
	290	98.42	2.50	6.3	193.634	-	-	-	10.0	NU5232M				
170	260	42.0	2.10	2.1	193.000	-	-	-	3.0	NU1034M				
	310	52.0	4.00	4.0	207.000	228.8	12	20.00	2.9	NU234EM	NJ234EM	NUP234EM		HJ234E
	310	104.77	3.20	6.3	205.483	-	-	-	10.0	NU5234M				
180	280	46.0	2.10	2.1	205.000	-	-	-	3.6	NU1036M				
	320	52.0	4.00	4.0	217.000	230.8	12	20.00	2.9	NU236EM	NJ236EM	NUP236EM		HJ236E
	320	86.0	4.00	4.0	218.000	230.5	12	29.00	6.9	NU2236M	NJ2236M	NUP2236M		HJ2236
200	310	51.0	2.10	2.1	229.000	-	-	-	4.2	NU1040M	NJ1040M			
	360	58.0	4.00	4.0	243.000	258.2	14	23.00	2.9	NU240EM	NJ240EM	NUP240EM		HJ240E
220	340	56.0	3.00	3.0	250.000	-	-	-	4.1	NU1044				
240	360	56.0	3.00	3.0	270.000	-	-	-	4.1	NU1048	NJ248			
	440	72.0	5.00	5.0	295.000	-	-	-	4.0	NU248	NJ248			
	440	72.0	5.00	5.0	295.000	315.0	16	25.90	4.0	NUJ248	NH248			HJ248
260	400	65.0	4.00	4.0	296.000	-	-	-	2.0	NU1052		NUP1052		
	480	130.0	5.00	5.0	320.000	-	-	-	4.3	NU2252				
280	420	65.0	4.00	4.0	316.000	-	-	-	5.0	NU1056				
300	460	74.0	5.00	5.0	340.000	-	-	-	4.5	NU1060	NJ1060			
	460	74.0	5.00	5.0	340.000	357.6	19	36.00	4.5	NUJ1060	NH1060			HJ1060
320	480	74.0	4.00	4.0	360.000	-	-	-	5.0	NU1064				
360	540	82.0	6.00	6.0	480.000	-	-	-	5.0	NU1072				
	540	82.0	6.00	6.0	480.000	423.0	21	39.50	5.0		NH1072			HJ1072
380	560	82.0	5.00	5.0	425.000	-	-	-	6.0	NU1076				
400	600	90.0	5.00	5.0	450.000	470.0	19.6	42.60	5.0	NU1080	NJ1080			HJ1080
	600	90.0	5.00	5.0	450.000	470.0	19.6	42.60	5.0	NU1080K				
	600	90.0	5.00	5.0	450.000	470.0	19.6	42.60	5.0	NUJ1080				
	600	148.0	5.00	5.0	450.000	-	-	-	5.0	NU3080				
	720	185.0	6.00	6.0	480.000	-	-	-	16.0	NU2280				
600	800	118.0	5.00	5.0	650.000	-	-	-	12.0	NU29/600		NUP29/600		
850	1120	155.0	8.00	8.0	925.000	-	-	-	15.0	NU29/850		NUP29/850		
900	1180	165.0	8.00	8.0	982.000	-	-	-	17.0	NU29/900		NUP29/900		
950	1250	175.0	10.00	10.0	1032.000	-	-	-	17.0	NU29/950		NUP29/950		
1000	1320	185.0	10.00	10.0	1090.000	-	-	-	17.0	NU29/1000		NUP29/1000		
1060	1400	195.0	10.00	10.0	1155.000	-	-	-	20.0	NU29/1060		NUP29/1060		
1180	1540	206.0	10.00	10.0	1280.000	-	-	-	21.0	NU29/1180		NUP29/1180		

¹⁾ Permissible axial displacement out of central position

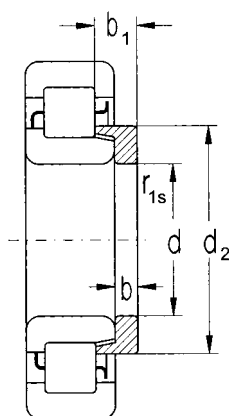

HJ

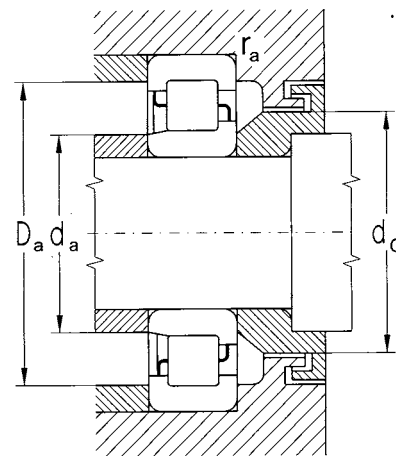
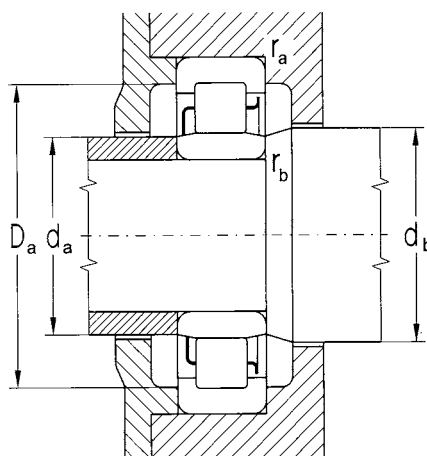

F

Basic Load Rating				Limiting Speed for Lubrication with		Abutment and Fillet Dimensions								Weight	
Dynamic C_r kN	Static C_{or} kN	Dynamic C_r lbs.	Static C_{or} lbs.	Grease	Oil	d	d_a min	d_a max	d_b min	d_c min	D_a max	r_a max	r_b max	Bearing	Angle Ring
				rpm		mm								kg	
511	631	114,878	141,855	2,000	2,400	160	174	180	197	210	276	2.5	2.5	14.7	1.50
764	1,310	171,755	294,501	1,900	2,200		186	-	199	-	261	5.0	2.0	28.9	-
276	376	62,048	84,529	2,200	2,700	170	179	190	197	-	248	2.0	2.0	7.9	-
607	750	136,460	168,608	1,900	2,200		188	195	211	223	293	3.0	3.0	16.6	1.70
891	1,470	200,306	330,471	1,800	2,100		197	-	211	-	279	5.0	3.0	35.5	-
329	447	73,962	100,490	2,100	2,500	180	189	196	209	-	268	2.0	2.0	10.5	-
631	794	141,855	178,499	1,800	2,100		198	207	220	233	302	3.0	3.0	19.5	1.80
736	1,060	165,460	238,299	1,800	2,100		198	208	221	233	302	3.0	3.0	31.2	1.90
383	531	86,102	119,374	1,900	2,200	200	212	220	233	-	298	2.0	2.0	14.0	-
779	1,000	175,127	224,810	1,500	1,800		218	227	246	261	342	3.0	3.0	28.4	2.70
501	694	112,629	156,017	1,700	200	220	234	240	254		326	2.5	2.5	18.5	-
531	764	212,221	287,757	1,600	1,900	240	254	260	275		346	2.5	2.5	20.0	-
944	1,280	212,221	287,757	1,300	1,600		258	293	298	316	422	3.0	3.0	50.5	-
944	1,280	212,221	287,757	1,300	1,600		258	293	298	316	422	3.0	3.0	50.5	4.68
643	962	144,553	216,267	1,400	1,700	260	278	280	300	-	382	3.0	3.0	29.0	-
1,760	2,900	395,664	651,946	1,100	1,400		280	309	324		460	4.0	4.0	90.0	-
681	1,020	153,096	229,306	1,300	1,600	280	296	311	320	-	404	3.0	3.0	32.5	-
891	1,310	200,306	294,501	1,200	1,400	300	318	325	344	360	442	3.0	3.0	43.6	-
891	1,310	200,306	294,501	1,200	1,400		318	325	344	360	442	3.0	3.0	43.6	5.63
909	1,390	204,351	312,484	1,100	1,300	320	336	355	364		464	3.0	3.0	48.5	-
1,076	1,753	241,894	394,090	950	1,100	360	382	390	410		518	4.0	4.0	67.5	-
1,076	1,753	241,894	394,090	950	1,100		382	390	410	427	518	4.0	4.0	67.5	10.00
1,166	1,082	262,127	243,243	850	1,000	380	400	420	430		540	4.0	4.0	71.0	-
1,470	2,330	330,471	523,807	840	1,000	400	422	435	455	-	578	4.0	4.0	89.0	10.50
1,470	2,330	330,471	523,807	840	1,000		422	435	455	-	578	4.0	4.0	89.0	-
1,470	2,330	330,471	523,807	840	1,000		422	435	455	-	578	4.0	4.0	89.0	-
2,255	4,900	506,944	1,101,564	760	910		422	435	456		578	4.0	4.0	150.5	-
3,410	5,960	766,602	1,339,868	710	840		426	460	485	-	694	5.0	5.0	350.0	-
2,230	4,853	501,324	1,090,998	500	700	600	614	644	654	675	750	4.0	4.0	173.0	-
3,760	8,740	845,286	1,964,839	380	450	850	878	920	930	952	1092	5.0	5.0	430.0	-
4,220	9,810	948,698	2,205,386	300	400	900	928	977	987	1011	1152	5.0	5.0	500.0	-
4,577	11,452	1,028,955	2,574,524	300	370	950	978	1027	1041	1066	1220	5.0	5.0	597.0	-
4,920	1,600	1,106,065	2,607,796	300	350	1000	1036	1085	1095	1122	1284	6.0	6.0	720.0	-
5,410	12,800	1,216,222	2,877,568	280	330	1060	1096	1150	1160	1189	1364	6.0	6.0	850.0	-
6,310	15,300	1,418,551	3,439,593	250	300	1180	1216	1275	1285	1316	1504	6.0	6.0	1,050.0	-

Single Row Cylindrical Roller Bearings for Special Applications

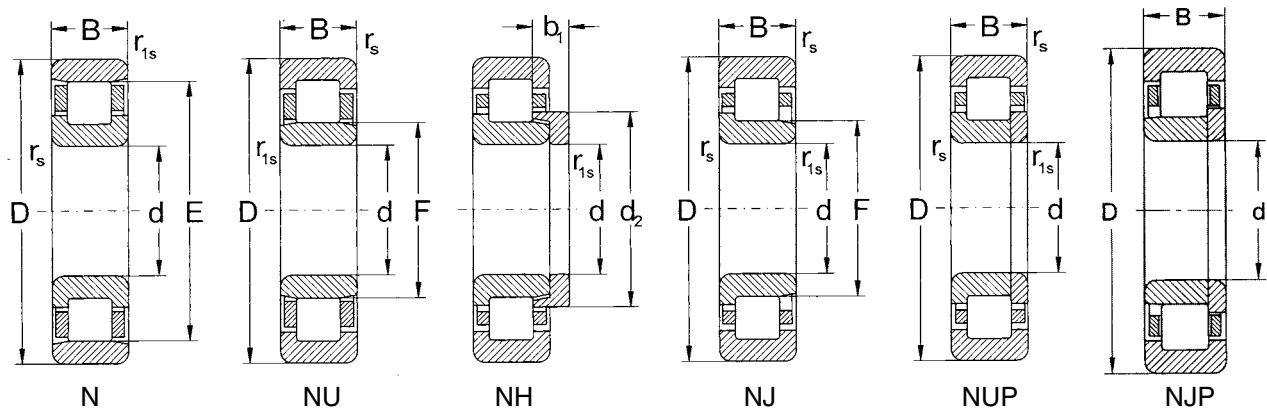

F

Dimension					Bearing Designation					
d	D	B	B ₁	b ₁	N / NJP	NUP	NU	NJ	NH	NUB
mm										
90	190	43	-	12.0	N318M	NUP318	NU318M	NJ318M	NH318M	
95	240	55	-	-		NUP419M	NU419M	NJ419M		
100	215	47	-	13.0					NH320W23B ²	
105	260	60	-	16.0		NUP421M	NU421M	NJ421M	NH421M	
110	240	50	-	-	N322M	NUP322M	NU322M	NJ322MA		
	240	50	80	-			NU322EM	NJ322EMA		NUB322EM
	280	65	-	-			NU422	NJ422M		
120	260	55	-	14.0			NU324M	NJ324M	NH324M	
	310	72	-	17.0		NUP424M	NU424M	NJ424M	NH424M	
130	280	58	-	14.0		NUP326EM	NU326EM/W23B ²	NJ326EM	NH326EM	
140	250	42	-	-	NJP228EMA					
	300	102	-	-			NU2328EM	NJ2328EM		
150	270	45	73	-	NJP230EMA	NUP230EM	NU230EM	NJ230EM		NUB230EM
	320	65	-	26.5		NUP330M	NU330M/W23B ²	NJ330M		
160	290	48	-	-		NUP232EM	NU232EM	NJ232EM		
170	310	52	-	-			NU234EM	NJ234EM		
	260	42	-	-			NU1034M		NH236EM	
180	320	52	-	20.0			NU236EM	NJ236EM		
	280	46	-	-			NU1036M			
190	290	46	-	-	NJP1038EMA					
198	310	51	66	-					PLC411-19 ¹⁾	
200	310	51	66	-			NU1040M	NJ1040M	NUB1040M	
	360	58	-	14.0				NH240EM		

¹⁾ Figure NUB

²⁾ W23B represents special conditions for use on traction motors

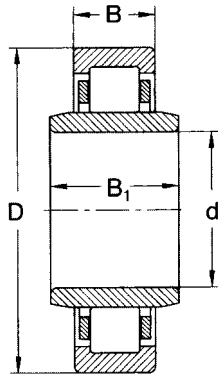

NUB

F

Basic Load Rating				Limiting Speed for Lubrication with		Weight	
Dynamic C _r kN	Static C _{0r} kN	Dynamic C _r lbs.	Static C _{0r} lbs.	Grease	Oil	Bearing	Angle Ring
				rpm		kg	
233	258	52,380	58,001	3,200	3,800	5.4	0.65
415	465	93,296	104,536	2,500	3,000	13.5	-
309	354	69,466	79,582	2,800	3,300	9.7	0.93
515	585	115,777	131,513	2,200	2,700	19.0	1.65
379	433	85,203	97,342	2,500	3,000	10.5	-
439	507	98,691	113,978	2,400	2,800	11.0	-
569	654	127,916	147,025	2,100	2,500	20.0	-
465	534	104,536	120,048	2,400	2,800	13.0	1.40
714	834	160,514	187,491	1,900	2,200	28.0	2.60
603	715	135,560	160,738	2,000	2,400	170.0	1.65
385	502	86,551	112,854	2,500	3,000	9.7	-
1018	1384	228,856	311,136	1,900	2,200	37.5	-
440	581	98,916	130,614	2,200	2,700	11.0	-
663	807	149,048	181,421	1,900	2,200	27.0	2.37
498	666	111,955	149,723	2,000	2,400	14.7	-
589	777	132,412	174,677	1,900	2,200	18.6	-
276	399	62,047	89,699	2,200	2,700	7.9	-
611	826	137,358	185,692	2,100	2,500	31.2	1.80
334	474	75,086	106,559	2,100	2,500	10.5	-
411	612	92,396	137,583	1,900	2,200	12.1	-
335	290	75,311	65,195	1,900	2,200	15.3	-
383	567	86,102	127,467	1,900	2,200	14.0	-
749	1,033	168,382	232,228	1,500	1,800	28.4	2.70

Single Row Cylindrical Roller Bearings for Special Applications

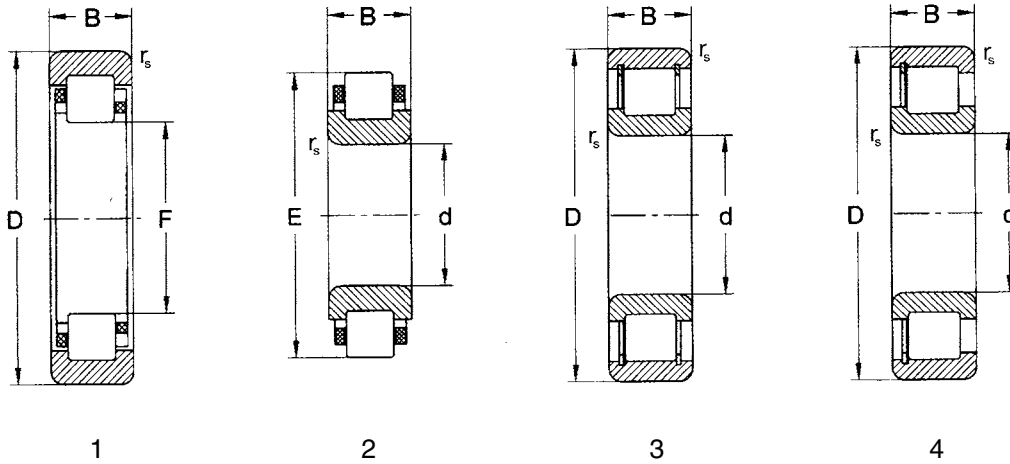

F

Dimension				Bearing Designation	Basic Load Rating			
d (F)	D(E)	B	r _s		Dynamic C _r	Static C _{0r}	Dynamic C _r	Static C _{0r}
mm					kN	kN	lbs.	lbs.
25	46.97	17	1.1	PLC 43-34/1	38.90	34.90	8,745	7,846
27.5	52	20	1.1	PLC 44-17	38.30	35.50	8,610	7,981
30	60	26	1.0	PLC 44-6	79.40	82.50	17,850	18,547
	80	21	1.1	PLC 45-201	71.30	79.40	16,029	17,850
32	65	21	1.0	NU22/32ENTNG	51.10	50.10	11,488	11,263
35	60	26	1.1	PLC 44-18	79.40	82.50	17,850	18,547
	80.03	21	1.1	PLC 45-17-1	76.40	77.90	17,175	17,513
40	60	24.75	-	PLC 44-20	79.40	82.50	17,850	18,547
	65	21	1.0	PLC 44-13	47.30	51.10	10,633	11,488
	65	21	1.0	PLC 44-13-1	49.20	54.10	11,061	12,162
	70.1	26	1.3	PLC 45-200	56.80	94.00	12,769	21,132
	90.03	23	2.0	PLC 46-20	87.44	96.20	19,657	21,627
49.93	80	15	0.6	PLC 45-202	41.80	51.20	9,397	11,510
50	72.1	31	-	PLC 55-200-1	116.00	184.00	26,078	41,365

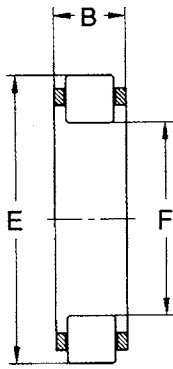

5

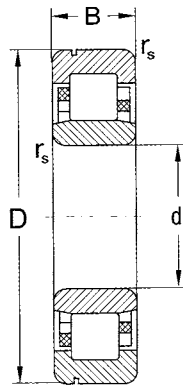

6

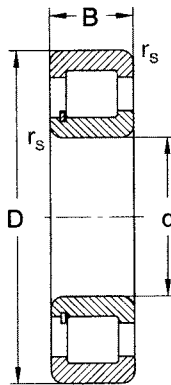

7

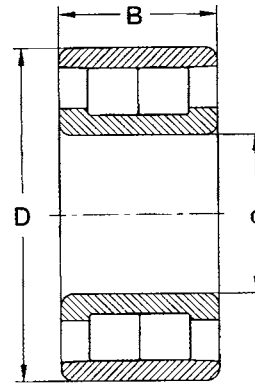

8

F

Limiting Speed for Lubrication with		Weight	Cage	Figure
Grease	Oil			
rpm		kg		
7,500	15,000	0.110	TNG	1
12,000	14,000	0.109	TNG	1
8,900	10,600	0.330	M	2
2,100	3,400	0.609	-	3
10,000	12,000	0.309	TNG	6
8,900	10,600	0.290	M	2
2,400	3,400	0.480	-	4
8,900	10,600	0.200	M	5
7,500	8,900	0.262	M	2
-	10,000	0.212	TNG	2
2,000	3,200	0.520	-	7
1,900	3,000	0.680	-	4
2,300	4,100	0.315	-	3
1,800	2,700	0.380	-	8

Single Row Cylindrical Roller Bearings for Special Applications

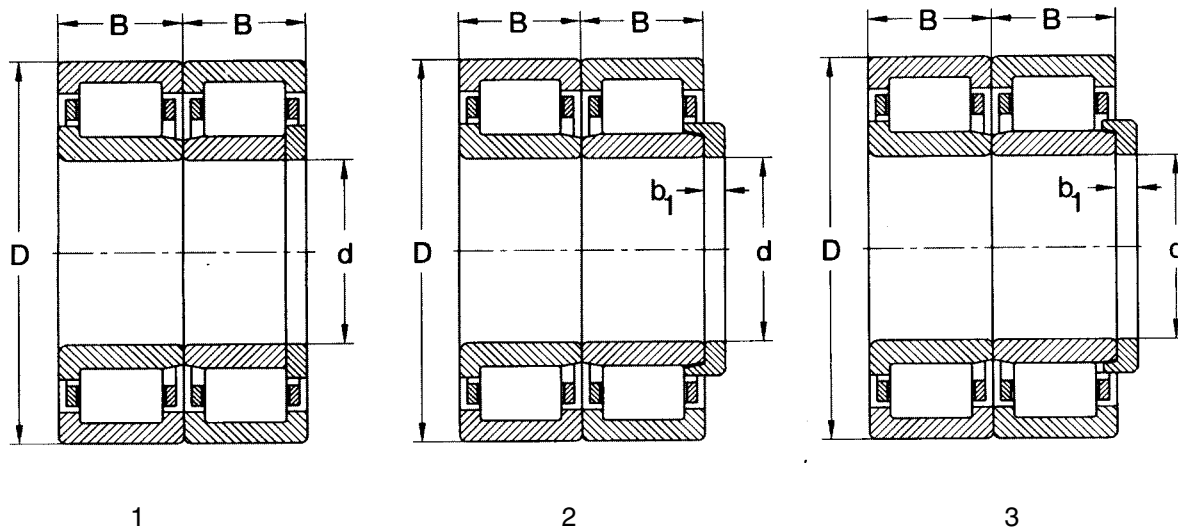

F

Dimension				Bearing Designation	
d	D	B	b ₁		
mm					
100	180	60.3	-	PLC 49-200-2	PLC 49-201-2 ¹⁾
110	215	73	-	PLC 410-207	PLC 410-208 ¹⁾
118	240	80	-	PLC 410-23	PLC 410-24
120	240	80	-	PLC 410-13	PLC 410-14 ¹⁾
	240	80	-	PLC 410-13-1	PLC 410-14-1 ¹⁾
	240	80	-	PLC 410-13-2	PLC 410-14-2 ¹⁾
130	240	80	-	PLC 410-15	PLC 410-16 ¹⁾
	240	80	-	PLC 410-33-1	PLC 410-34-1 ¹⁾
	240	80	-	PLC 410-33-2	PLC 410-34-2 ¹⁾
	250	80	-	PLC 410-17	PLC 410-18
159	300	84	15	PLC 411-20	PLC 411-21
160	300	84	15	PLC 411-10	PLC 411-12
180	320	86	12	NJ2236M C4A450-900	NUC2236M C4 + HJ2236X16.33
	320	86	15	NJ2236XM C4	NUC2236M C4 + PLC810-1
	320	86	15	NJ2236XMAS C4	NUC2236MAS C4 + PLC810-1
	320	86	17	NJ2236XM C4	NUC2236M C4 + angle ring NUP2236

¹⁾ Bearings correspond to International Railway Standards UIC 510 - 1 and KN 024617.

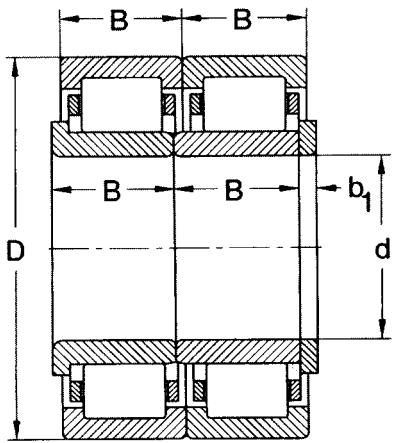

4

F

Basic Load Rating				Maximum Speed of Rail Vehicle	Weight Per Pair	Cage	Figure
Dynamic C_r	Static C_{or}	Dynamic C_r	Static C_{or}				
kN	kN	lbs.	lbs.	rpm	kg		
333	444	74,861	99,815	160	12.0	TNG	1
494	668	111,056	150,172	160	24.9	M	1
553	742	124,319	166,808	160	34.2	M	1
553	742	124,319	166,808	160	33.7	M	1
553	742	124,319	166,808	160	31.7	M	1
553	742	124,319	166,808	160	30.1	TNG	1
516	752	116,001	169,056	160	32.7	M	1
539	775	121,172	174,227	160	32.7	M	1
539	775	121,172	174,227	160	30.2	TNG	1
580	800	130,389	179,847	160	36.6	M	1
869	1,214	195,359	272,918	160	58.2	M	2
869	1,214	195,359	272,918	160	57.5	M	2
713	1,082	160,289	243,243	160	64.4	M	3
713	1,082	160,289	243,243	160	64.5	M	3
713	1,082	160,289	243,243	160	64.5	MAS	3
713	1,082	160,289	243,243	160	64.6	M	4

Single Row Cylindrical Roller Bearings - Type VL

d = 7.8 to 25 mm

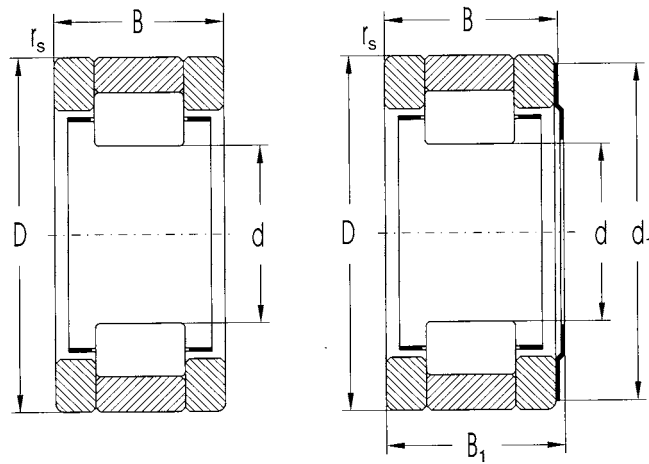

F

Dimension						Basic Load Rating			
d	d ₁	D	B	B ₁	r _s min	Dynamic C _r	Static C _{or}	Dynamic C _r	Static C _{or}
mm						kN	kN	lbs.	lbs.
7.8	-	18	9	-	0.4	4.22	2.82	949	634
8.11	-	18	9	-	0.4	4.30	2.87	967	645
8.8	-	20	10	-	0.4	5.01	3.55	1,126	798
10	-	22	12	-	0.6	6.81	4.55	1,531	1,023
	-	22	12	-	0.6	7.50	5.21	1,686	1,171
	21.7	22	10.2	11.4	0.6	7.50	5.21	1,686	1,171
12	-	26	14	-	0.6	11.00	7.79	2,473	1,751
	-	26	14	-	0.6	12.10	8.91	2,720	2,003
14	-	30	14	-	0.6	12.30	8.74	2,765	1,965
	-	30	14	-	0.6	13.60	10.00	3,057	2,248
16	-	35	17	-	0.6	16.50	12.30	3,709	2,765
18	-	36	17	-	0.6	17.10	14.40	3,844	3,237
20	-	40	19	-	0.6	20.30	17.40	4,564	3,912
25	-	48	19	-	0.6	24.60	22.80	5,530	5,126

Limiting Speed for Lubrication with		Bearing Designation	Weight	Cage	Dimension Deviation					
Grease	Oil				Δd_{mp}		ΔD_{mp}		ΔB_2	
rpm					max	min	max	min	max	min
				μm						
34,000	39,000	VL 7.8	0.010	TNG	+28	+16	+10	0	+70	-30
34,000	39,000	VL 8.1	0.010	TNG	+10	0	+8	0	+70	-30
32,000	37,000	VL 8.8	0.011	TNG	+33	+23	+7	0	+70	-30
21,000	25,000	VL 10	0.021	M	+42	+25	+10	0	+70	-30
30,000	35,000	VL 10E	0.020	TNG	+42	+25	+10	0	+70	-30
30,000	35,000	VL 10ZETNG	0.021	TNG	+28	+20	+10	0	+70	-30
18,000	21,000	VL 12	0.032	M	+42	+25	+10	0	+70	-30
25,000	30,000	VL 12E	0.031	TNG	+42	+25	+10	0	+70	-30
15,000	18,000	VL 14	0.014	M	+42	+25	+10	0	+70	-30
22,000	27,000	VL 14E	0.042	TNG	+42	+25	+10	0	+70	-30
13,000	16,000	VL 16	0.073	M	+42	+25	+10	0	+70	-30
12,600	15,000	VL 18	0.076	M	+42	+25	+10	0	+70	-30
12,000	14,000	VL 20	0.107	M	+42	+25	+10	0	+70	-30
9,400	11,000	VL 25	0.155	M	+42	+25	+10	0	+70	-30

Double Row Cylindrical Roller Bearings

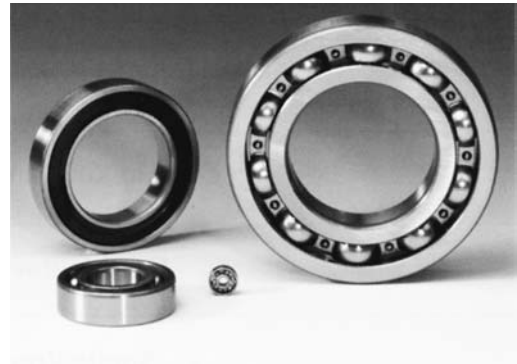

Double row cylindrical roller bearings, NN design, have two rows of cylindrical rollers guided by three ribs on the inner ring. The outer ring has no guide ribs, making the outer ring separable. This is why these bearings cannot carry axial loads. Double row cylindrical roller bearings, type NN30K, are commonly produced with a tapered bore (1:12 taper). These bearings are also available with cylindrical bores upon request.

Double row cylindrical roller bearings, NNU49, have three guiding ribs on the outer ring and a smooth inner ring. This design allows the inner ring to be separable. These bearings are only designed to carry radial loads; axial loads should not be applied.

G

Double row cylindrical roller bearings are significant for their great rigidity and are predominately used in the spindles of machine tools and similar equipment.

Lubrication Groove and Holes on Outer Ring

All sizes of double row cylindrical roller bearings with tapered bore can be delivered with groove and lubrication holes on the outer ring (W33). This design allows the introduction of the lubricant directly into the bearing between two cylindrical roller rows. This produces a better lubrication system for the bearing and a higher operating reliability can be achieved.

Cage

Double row cylindrical roller bearings are produced with a machined brass (M) cage; other cage types may be available upon request.

Boundary Dimensions

Boundary dimensions comply with the standard ISO 15.

Tolerance

Double row cylindrical roller bearings with tapered bores are produced only in higher tolerance classes P5 and P4. Bearings NNU49 and NN39 are produced in normal tolerance class ABEC 1 or P0.

Radial Clearance

Double row cylindrical roller bearings with a tapered bore are produced with reduced radial clearance and with non-interchangeable rings (C1NA and C2NA). Symbols C1NA and C2NA are connected with tolerance class symbols P5 and P4; e.g., P5 + C1NA is designated P51NA. The NNU49 bearings are produced with normal radial clearance (C0). These bearings may be available with a larger radial clearance upon request. Bearings with a radial clearance greater than C3 should be discussed with the supplier. Listed in the chart below are values for radial clearance.

Radial Clearance of Double Row Cylindrical Roller Bearings with Tapered Bore with Non-Interchangeable Rings Determined for Machine Tool Spindles					
Bore Diameter		Radial Clearance			
d		C1NA		C2NA	
over	to	min	max	min	max
mm		µm			
24	30	15	25	25	35
30	40	15	25	25	40
40	50	17	30	30	45
50	65	20	35	35	50
65	80	25	40	40	60
80	100	35	55	45	70
100	120	40	60	50	80
120	140	45	70	60	90
140	160	50	75	65	100
160	180	55	85	75	110
180	200	60	90	80	120
200	225	60	95	90	135
225	250	65	100	100	150
250	280	75	110	110	165
280	315	80	120	120	180
315	355	90	135	135	200
355	400	100	150	150	225
400	450	110	170	170	255

G

Misalignment

Double row cylindrical roller bearings will take little to no misalignment.

Radial Equivalent Dynamic Load

$$P_r = F_r \quad [\text{kN}]$$

Radial Equivalent Static Load

$$P_{or} = F_r \quad [\text{kN}]$$

Designation

Listed below are some common designations for our double row cylindrical roller bearings.

Double Row Cylindrical Roller Bearings		
Suffix	Description	Example of Designation
K	Tapered bearing bore at a 1:12 ratio	NN3009 K
W33	Lubrication groove and holes in the outer ring	NN3040K W33
M	Machined brass cage guided on the rolling elements	NN3068K MC3
MB	Machined brass cage guided on the inner ring	NN3944K MB
P6	Higher tolerance class than normal	NNU49/630K P6
P5	Higher tolerance class than P6	NN3040K P5
P4	Higher tolerance class than P5	NN3026K P4
C1	Radial clearance less than C2	NN3012K C1
C2	Radial clearance less than normal	NN3020K C2
C3	Radial clearance greater than normal	NN3068KM C3
C4	Radial clearance greater than C3	NN3072K C4
C5	Radial clearance greater than C4	NN3056K C5

Double Row Cylindrical Roller Bearings

d = 200 to 630 mm

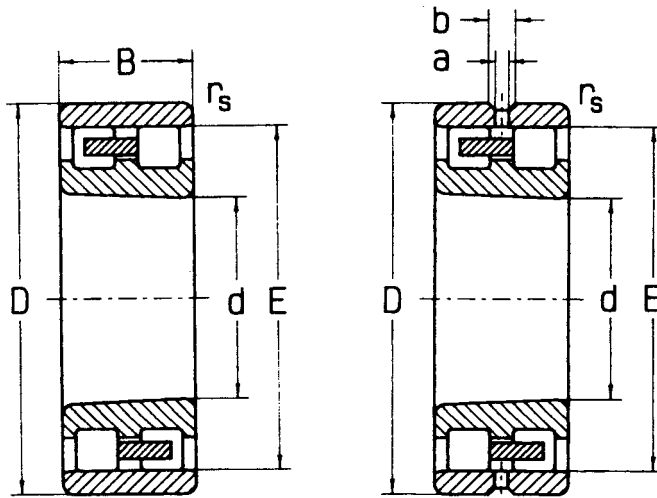

W33

G

Dimension							Basic Load Rating			
d	D	B	r _s min	E	F	s ¹⁾	Dynamic C _r	Static C _{0r}	Dynamic C _r	Static C _{0r}
mm							kN	kN	lbs.	lbs.
200	310	200	2.1	-	229	4.0	1,723	3,953	387,346	888,670
220	300	60	3.5	278	-	2.0	299	668	404,658	494,582
240	320	60	3.5	298	-	2.0	316	750	359,696	449,620
280	420	106	5.0	384	-	6.0	1,100	2,000	292,253	359,696
320	480	121	5.0	438	-	8.0	1,360	2,510	269,772	314,734
340	520	133	6.0	473	-	9.0	1,680	3,100	247,291	292,253
360	540	134	6.0	493	-	9.0	1,740	3,350	224,810	269,772
440	650	157	8.0	596	-	13.0	2,460	4,920	168,608	200,081
630	850	218	8.0	-	704	5.0	3,910	10,200	105,661	155,119
	920	515	10.0	-	719	17.0	8,775	26,880	1,972,698	6,042,864
	920	515	10.0	-	719	17.0	11,725	39,320	2,635,885	8,839,488

¹⁾ Permissible axial displacement

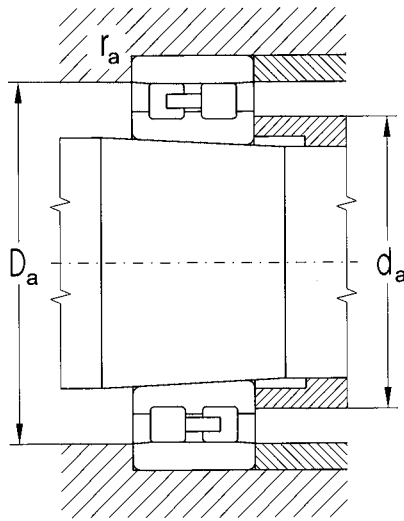

G

Limiting Speed for Lubrication with		Bearing Designation		Abutment and Fillet Dimensions					Weight	
Grease	Oil	with Cylindrical Bore	with Tapered Bore	d	d _a min	D _a min	D _a max	r _a max		K
rpm				mm					kg	
1,700	2,200	NNU6040		200	220	270	290	2	60.0	-
1,800	2,200	NN3944		220	238	280	285	3	12.0	-
1,600	2,000	NN3948		240	258	300	305	3	13.0	-
1,300	1,600	NN3056K		280	298	388	402	3	-	49.6
1,200	1,400	NN3064K		320	338	442	462	3	-	74.2
1,100	1,300	NN3068K		340	362	477	498	4	-	99.0
1,000	1,200	NN3072K		360	382	497	518	4	-	105.0
750	890	NN3088K		440	468	602	622	5	-	169.4
470	600	NNU49/630		630	670	775	810	6	363.0	-
430	500	NNU60/630		-	670	775	810	6	1,235.0	-
110	210	NNU60/630V		-	670	775	810	6	1,280.0	-

Double Row Cylindrical Roller Bearings for Special Applications

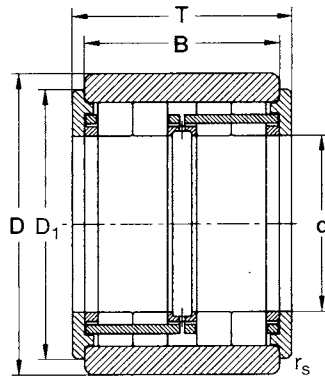

G

Dimension						Bearing Designation	Basic Load Rating				Limiting Speed for Oil rpm	Weight kg	Cage
d	D	B	T	r_s min.	D_1		Dynamic C_r	Static C_{or}	Dynamic C_r	Static C_{or}			
mm							kN	kN	lbs.	lbs.			
65	120	88	78	2	104	PLC 56-2	208	216	46,760	48,559	7,100	4.9	M

This page left blank intentionally.

Double Row Spherical Roller Bearings



ZVL-ZKL double row spherical roller bearings have two rows of barrel-shaped rollers with a common spherical raceway in the outer ring. By virtue of their design, spherical roller bearings are self-aligning. Under load, the rollers rest against the face of an integral center guide flange on the bearing inner ring.

These bearings are most suitable for applications where some misalignment is unavoidable. Double row spherical roller bearings can carry heavy radial and combined axial loads in both directions simultaneously. They are available with either cylindrical or tapered bores to suit your application requirements.

Selected sizes of ZVL-ZKL double row spherical roller bearings are available in the "C" or "E" design; additional sizes are gradually being introduced into standard production. This design change eliminates the guide flanges on the bearing inner ring and uses longer rollers. This change increases the basic load-carrying capacity of the bearing. The pictures below show our internal designs for double row spherical roller bearings with regard to its design or cage selection.

H

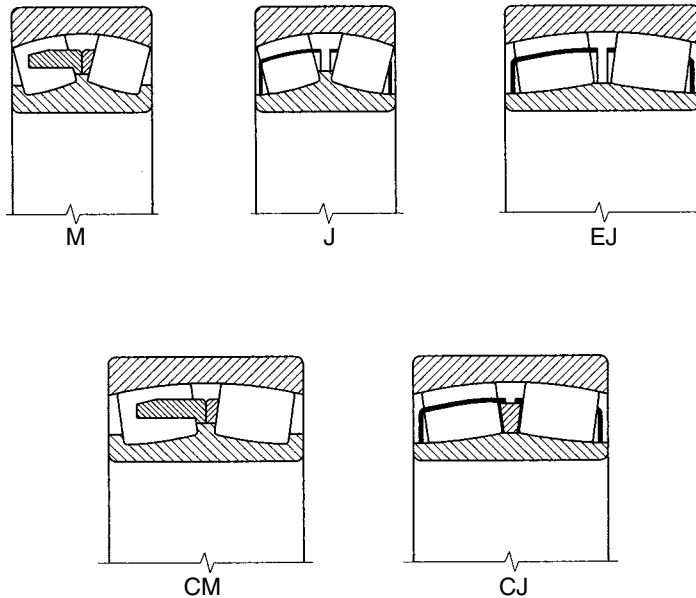

Heat Treatment

Double row spherical roller bearings are heat treated which allows their maximum operating temperature to be 356 °F.

Lubrication Groove and Holes

All double row spherical roller bearings are produced with a lubrication groove and holes, designation W33.

Cage

Double row spherical roller bearings are produced with either a pressed steel (J) or machined brass (M) cage. In the dimension tables each part number is shown with either a “J” or “M”, designating its cage design.

Boundary Dimensions

All boundary dimensions comply with standard ISO 15.

Tolerance

All double row spherical roller bearings are produced within ABEC 1 or P0 tolerance class. Standard ISO 199 and ISO 492 specify these tolerances. Bearings that require a higher tolerance class may be produced upon request.

Radial Clearance

Double row spherical roller bearings are produced with a radial clearance of C0 or C3 as normal production. Other radial clearances may be produced upon request. All radial clearance values comply with standard ISO 5753 and are listed in the charts below.

Radial Clearance of Double Row Spherical Roller Bearings											
Bore Diameter		Cylindrical Bore Radial Clearance									
d		C2		normal		C3		C4		C5	
over	to	min	max	min	max	min	max	min	max	min	max
mm		µm									
30	40	15	30	30	45	45	60	60	80	80	100
40	50	20	35	35	55	55	75	75	100	100	125
50	65	20	40	40	65	65	90	90	120	120	150
65	80	30	50	50	80	80	110	110	145	145	180
80	100	35	60	60	100	100	135	135	180	180	225
100	120	40	75	75	120	120	160	160	210	210	260
120	140	50	95	95	145	145	190	190	240	240	300
140	160	60	110	110	170	170	220	220	280	280	350
160	180	65	120	120	180	180	240	240	310	310	390
180	200	70	130	130	200	200	260	260	340	340	430
200	225	80	140	140	220	220	290	290	380	380	470
225	250	90	150	150	240	240	320	320	420	420	520
250	280	100	170	170	260	260	350	350	460	460	570
280	315	110	190	190	280	280	370	370	500	500	630
315	355	120	200	200	310	310	410	410	550	550	690
355	400	130	220	220	340	340	450	450	600	600	760
400	450	140	240	240	370	370	500	500	660	660	820
450	500	140	260	260	410	410	550	550	720	720	900
500	560	150	280	280	440	440	600	600	780	780	1000
560	630	170	310	310	480	480	650	650	850	850	1100
630	710	190	350	350	530	530	700	700	920	920	1190
710	800	210	390	390	580	580	770	770	1010	1010	1300
800	900	230	430	430	650	650	860	860	1120	1120	1440

H

Radial Clearance of Double Row Spherical Roller Bearings											
Bore Diameter		Tapered Bore Radial Clearance									
d		C2		normal		C3		C4		C5	
over	to	min	max	min	max	min	max	min	max	min	max
mm		µm									
30	40	25	35	35	50	50	65	65	85	85	105
40	50	30	45	45	60	60	80	80	100	100	130
50	65	40	55	55	75	75	95	95	120	120	160
65	80	50	70	70	95	95	120	120	150	150	200
80	100	55	80	80	110	110	140	140	180	180	230
100	120	65	100	100	135	135	170	170	220	220	280
120	140	80	120	120	160	160	200	200	260	260	330
140	160	90	130	130	180	180	230	230	300	300	380
160	180	100	140	140	200	200	260	260	340	340	430
180	200	110	160	160	220	220	290	290	370	370	470
200	225	120	180	180	250	250	320	320	410	410	520
225	250	140	200	200	270	270	350	350	450	450	570
250	280	150	220	220	300	300	390	390	490	490	620
280	315	170	240	240	330	330	430	430	540	540	680
315	355	190	270	270	360	360	470	470	590	590	740
355	400	210	300	300	400	400	520	520	650	650	820
400	450	230	330	330	440	440	570	570	720	720	910
450	500	260	370	370	490	490	630	630	790	790	1000
500	560	290	410	410	540	540	680	680	870	870	1100
560	630	320	460	460	600	600	760	760	980	980	1230
630	710	350	510	510	670	670	850	850	1090	1090	1360
710	800	390	570	570	750	750	950	950	1220	1220	1500
800	900	440	640	640	840	840	1070	1070	1370	1370	1690

Tapered Bore

Bearings with a tapered bore have a taper of 1:12. Bearings in the 240 design have a taper of 1:30, designation K30. Bearings with a tapered bore are mounted onto shafts by use of adapter sleeves, or sometimes mounted directly to a tapered shaft. Corresponding adapter sleeves are noted with each part number.

Misalignment

These bearings are designed to take a considerable amount of misalignment. Listed in the table below are the approximate permissible misalignment values.

Bearing Type	Permissible Misalignment
239, 230, 231, 222	1°30'
223	2°
232	2°30'

Radial Equivalent Dynamic Load

$$P_r = F_r + Y_1 F_a \quad \text{for } F_a / F_r \leq e \quad [\text{kN}]$$

$$P_r = 0.67 F_r + Y_2 F_a \quad \text{for } F_a / F_r > e \quad [\text{kN}]$$

Factor values e , Y_1 , and Y_2 for individual bearings are indicated in dimension tables.

Radial Equivalent Static Load

$$P_{or} = F_r + Y_0 F_a \quad [\text{kN}]$$

Factor values Y_0 for individual bearings are indicated in the dimensional tables.

Designation

Listed below are some common designations for double row spherical roller bearings.

Double Row Spherical Roller Bearings		
Suffix	Description	Example of Designation
K	Tapered bearing bore at a 1:12 ratio	22214 KJ
K30	Tapered bearing bore at a 1:30 ratio	24056 K30M
W33	Lubrication groove and holes in the outer ring	22223 W33M
J	Pressed steel cage guided on the rolling elements	22310 J
M	Machined brass cage guided on the rolling elements	23156 M
C2	Radial clearance less than normal	23032M C2
C3	Radial clearance greater than normal	22222J C3
C4	Radial clearance greater than C3	23164 C4
C5	Radial clearance greater than C4	22334M C5
S0	Heat stabilized for an operating temperature up to 302°F (150°C)	22320M C3S0
S1	Heat stabilized for an operating temperature up to 392°F (200°C)	23048M C4S1
S2	Heat stabilized for an operating temperature up to 482°F (250°C)	22219J S2
S3	Heat stabilized for an operating temperature up to 572°F (300°C)	23224KM C3S3
S4	Heat stabilized for an operating temperature up to 662°F (350°C)	23032M C2S4
S5	Heat stabilized for an operating temperature up to 752°F (400°C)	23226M S5

Double Row Spherical Roller Bearings

d = 25 to 95 mm

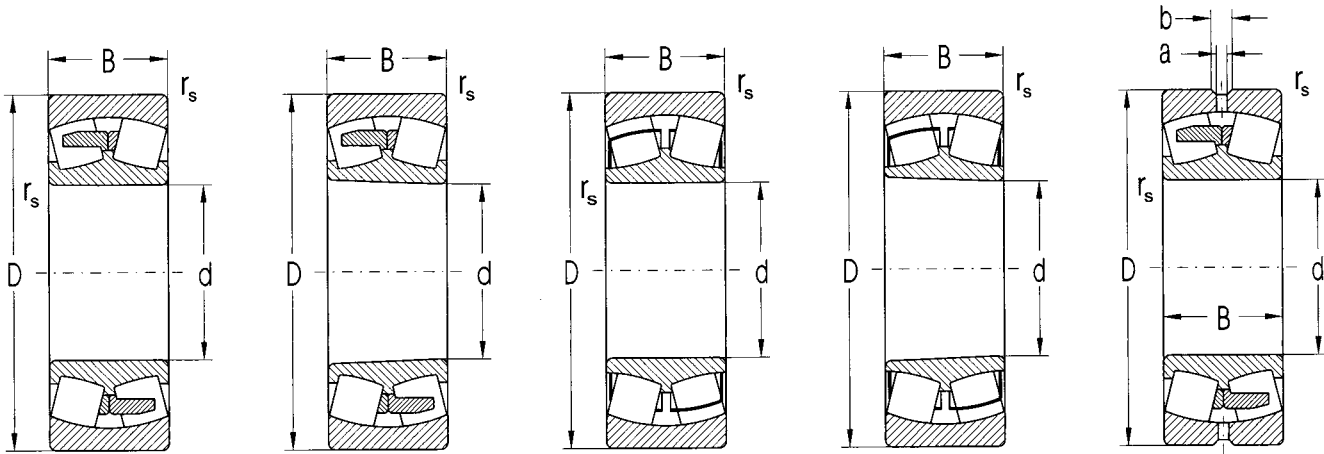

M

KM

J

KJ

W33

Dimension						Basic Load Rating				Limiting Speed for Lubrication with		Bearing Designation	
d	D	B	rs min	a	b	Dynamic Cr	Static Cor	Dynamic Cr	Static Cor	Grease	Oil	with Cylindrical Bore	with Tapered Bore
mm						kN	kN	lbs.	lbs.	rpm			
25	52	18	1.0	3.0	2.6	44	43	9,892	9,667	8,900	11,000	22205EJ	22205EKJ
30	62	20	1.0	3.0	3.3	58	61	13,039	13,713	7,500	9,500	22206EJ	22206EKJ
35	72	23	1.1	3.0	3.3	78	88	17,535	19,783	6,300	8,000	22207EJ	22207EKJ
40	80	23	1.1	3.0	3.8	90	100	20,233	22,481	6,000	7,500	22208EJ	22208EKJ
	90	33	1.5	3.0	5.5	100	108	22,481	24,279	4,000	4,700	22308J	22308KJ
45	85	23	1.1	3.0	3.9	94	108	21,132	24,279	5,300	6,700	22209EJ	22209EKJ
	100	36	1.5	3.0	5.5	116	132	26,078	29,675	3,800	4,500	22309J	22309KJ
50	90	23	1.1	3.0	3.9	101	118	22,706	26,527	5,000	6,300	22210EJ	22210EKJ
	110	40	2.0	3.0	5.5	156	180	35,070	40,466	3,300	4,000	22310J	22310KJ
55	100	25	1.5	3.0	4.4	120	142	26,977	31,923	4,500	5,600	22211EJ	22211EKJ
	120	43	2.0	3.0	5.5	173	200	38,892	44,962	2,800	3,300	22311J	22311 KJ
60	110	28	1.5	3.0	5.5	140	174	31,473	39,117	4,000	5,000	22212EJ	
	130	46	2.1	3.0	5.5	232	263	52,156	59,125	2,800	3,600	22312J	22312KJ
	130	46	2.1	3.0	5.5	226	254	50,807	57,101	2,800	3,600	22312M	22312KM
65	120	31	1.5	3.0	5.5	177	216	39,791	48,559	2,600	3,400	22213EJ	
	140	48	2.1	3.0	5.5	230	268	51,706	60,249	2,700	3,200	22313J	22313KJ
	140	48	2.1	3.0	5.5	240	279	53,954	62,722	2,600	3,400	22313M	22313KM
	140	48	2.1	3.0	5.5	304	351	68,342	78,908	2,600	3,400	22313EJ	22313EKJ
70	125	31	1.5	3.0	5.5	189	239	42,489	53,729	3,600	4,500	22214EW33J	22214EKW33J
	125	31	1.5	3.0	5.5	146	182	32,822	40,915	3,600	4,500	22214J	22214KJ
	150	51	2.1	3.0	5.5	316	370	71,040	83,179	2,400	3,000	22314J	22314KJ
	150	51	2.1	3.0	5.5	309	360	69,466	80,931	2,400	3,000	22314M	22314KM
75	130	31	1.5	3.0	5.5	196	255	44,063	57,326	3,400	4,300	22215EW33J	22215EKW33J
	130	31	1.5	3.0	5.5	151	194	33,946	43,613	3,400	4,300	22215J	22215KJ
	130	31	1.5	3.0	5.5	196	255	44,063	57,326	3,400	4,300	22215EJ	22215EKJ
	160	55	2.1	4.5	8.3	325	401	73,063	90,148	2,200	3,000	22315J	22315KJ
	160	55	2.1	4.5	8.3	318	390	71,489	87,675	2,200	3,000	22315M	22315KM
80	140	33	2.0	3.0	5.5	224	295	50,357	66,319	3,200	4,000	22216EJ	22216EKJ
	140	33	2.0	3.0	5.5	224	295	50,357	66,319	3,200	4,000	22216EW33J	22216EKW33J
	140	33	2.0	3.0	5.5	180	228	40,466	51,256	3,200	4,000	22216J	22216KJ
	140	33	2.0	3.0	5.5	171	226	38,442	50,807	3,200	4,000	22216M	22216KM
	170	58	2.1	4.5	8.3	380	458	85,427	102,962	2,000	2,800	22316J	22316KJ
	170	58	2.1	4.5	8.3	373	447	83,854	100,490	2,000	2,800	22316M	22316KM
85	150	36	2.0	3.0	5.5	260	337	58,450	75,761	3,000	3,800	22217EJ	22217EKJ
	150	36	2.0	3.0	5.5	260	337	58,450	75,761	3,000	3,800	22217EW33J	22217EKW33J
	150	36	2.0	3.0	5.5	208	258	46,760	58,001	3,000	3,800	22217J	22217KJ
	150	36	2.0	3.0	5.5	192	247	43,163	55,528	3,000	3,800	22217M	22217KM
	180	60	3.0	4.5	8.3	403	489	90,598	109,932	1,900	2,600	22317J	22317KJ
	180	60	3.0	4.5	8.3	399	481	89,699	108,133	1,900	2,600	22317M	22317KM
90	160	40	2.0	4.5	8.3	308	406	69,241	91,272	2,600	3,400	22218EW33J	22218EKW33J
	160	40	2.0	4.5	8.3	230	300	51,706	67,443	2,600	3,400	22218M	22218KM
	160	40	2.0	4.5	8.3	240	302	53,954	67,892	2,600	3,400	22218J	22218KJ
	160	40	2.0	4.5	8.3	308	406	69,241	91,272	2,600	3,400	22218EM	22218EKM
	160	52.4	2.0	3.0	5.5	326	452	73,288	101,614	1,900	2,600	23218M	23218KM
	190	64	3.0	4.5	8.3	465	566	104,536	127,242	1,800	2,400	22318J	22318KJ
	190	64	3.0	4.5	8.3	461	559	103,637	125,668	1,800	2,400	22318M	22318KM
95	170	43	2.1	4.5	8.3	346	464	77,784	104,311	2,400	3,200	22219EW33J	22219EKW33J
	170	43	2.1	4.5	8.3	276	353	62,047	79,358	2,400	3,200	22219J	22219KJ
	170	43	2.1	4.5	8.3	278	361	62,497	81,156	2,400	3,200	22219M	22219KM
	200	67	3.0	4.5	8.3	502	611	112,854	137,358	1,800	2,400	22319M	22319KM

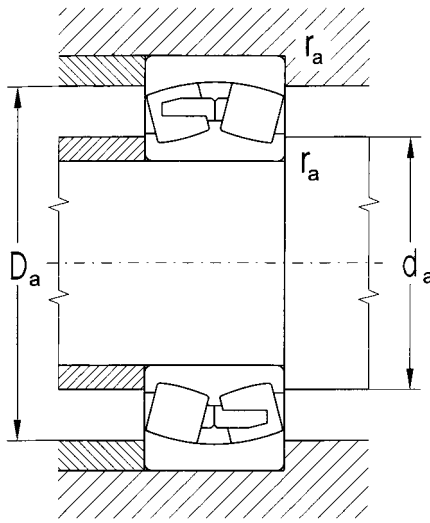

Abutment and Fillet Dimensions				Weight		Corresp. Adapter Sleeve	Corresp. Withdrawal Sleeve	Corresp. Nut	Factors			
d	d_a min	D_a max	r_a max		K				e	Y_1	Y_2	Y_0
mm				kg								
25	30	47	1.0	0.16	0.16	H305	-	KM5	0.34	2.00	3.00	2.00
30	35	57	1.0	0.25	0.25	H306	-	KM6	0.31	2.10	3.20	2.10
35	42	65	1.0	0.42	0.42	H307	-	KM7	0.31	2.20	3.30	2.10
40	47	73	1.0	0.49	0.48	H308	AH308	KM9	0.27	2.50	3.70	2.40
	47	81	1.5	1.03	0.98	H2308	AH2308	KM9	0.42	1.60	2.40	1.60
45	52	78	1.0	0.54	0.53	H309	AH309	KM10	0.26	2.60	3.90	2.60
	52	91	1.5	1.40	1.37	H2309	AH2309	KM10	0.42	1.60	2.40	1.60
50	57	83	1.2	0.57	0.56	H310	AH310X	KM11	0.24	2.80	4.20	2.80
	60	100	2.0	1.90	1.86	H2310	AH2310X	KM11	0.42	1.60	2.40	1.60
55	62	91	1.5	0.78	0.76	H311	AH311X	KM12	0.23	2.90	4.40	2.90
	65	110	2.0	2.40	2.35	H2311	AH2311X	KM12	0.42	1.60	2.40	1.60
60	67	101	1.5	1.07		H312	AH312X	KM13	0.24	2.80	4.20	2.80
	72	118	2.0	2.80	2.70	H2312	AH2312X	KM13	0.41	1.60	2.35	1.55
	72	118	2.0	3.00	2.90	H2312	AH2312X	KM13	0.41	1.63	2.35	1.55
65	72	111	1.5	1.44		H313	AH313	KM15	0.24	2.90	4.20	2.80
	76	128	2.0	3.31	3.23	H2313	AH2313	KM15	0.38	1.80	2.54	1.67
	76	128	2.0	3.60	3.50	H2313	AH2313	KM15	0.38	1.80	2.54	1.67
	76	128	2.0	3.50	3.40	H2313	AH2313	KM15	0.38	1.80	2.54	1.67
70	77	116	1.5	1.61	1.57	H314	AH314	KM16	0.23	2.93	4.23	2.79
	77	116	1.5	1.60	1.50	H314	AH314	KM16	0.24	2.80	4.20	2.80
	81	138	2.0	4.20	4.10	H2314	AH2314X	KM16	0.37	1.80	2.60	1.72
	81	138	2.0	4.30	4.20	H2314	AH2314X	KM16	0.37	1.80	2.60	1.72
75	82	121	1.5	1.70	1.66	H315	AH315	KM17	0.22	3.11	4.49	2.97
	82	121	1.5	1.70	1.66	H315	AH315	KM17	0.23	3.00	4.40	2.90
	82	121	1.5	1.70	1.66	H315	AH315	KM17	0.22	3.11	4.49	2.97
	86	148	2.0	5.50	5.40	H2315	AH2315X	KM17	0.38	1.761	2.60	1.67
	86	148	2.0	5.40	5.20	H2315	AH2315X	KM17	0.38	1.761	2.60	1.67
80	90	130	2.0	2.10	2.00	H316	AH316	KM18	0.21	3.20	4.62	3.05
	90	130	2.0	2.10	2.00	H316	AH316	KM18	0.21	3.20	4.62	3.05
	90	130	2.0	2.10	2.00	H316	AH316	KM18	0.24	2.835	4.00	2.70
	90	130	2.0	2.20	2.10	H316	AH316	KM18	0.26	2.60	3.80	2.50
	91	158	2.0	6.40	6.20	H2316	AH2316X	KM18	0.37	1.84	2.766	1.755
	91	158	2.0	6.30	6.20	H2316	AH2316X	KM18	0.37	1.84	2.766	1.755
85	95	140	2.0	2.66	2.61	H317	AH317X	KM19	0.22	3.04	4.39	2.90
	95	140	2.0	2.66	2.61	H317	AH317X	KM19	0.22	3.04	4.39	2.90
	95	140	2.0	2.60	2.50	H317	AH317X	KM19	0.24	2.80	4.00	2.65
	95	140	2.0	2.80	2.70	H317	AH317X	KM19	0.26	2.60	3.70	2.50
	98	166	2.5	7.10	7.00	H2317	AH2317X	KM19	0.37	1.90	2.70	1.80
	98	166	2.5	7.40	7.20	H2317	AH2317X	KM19	0.37	1.90	2.70	1.80
90	100	150	2.0	3.40	3.29	H318	AH318X	KM20	0.23	2.93	4.24	2.80
	100	150	2.0	3.60	3.40	H318	AH318X	KM 20	0.26	2.60	3.70	2.50
	100	150	2.0	3.30	3.20	H318	AH318X	KM20	0.26	2.60	3.80	2.50
	100	150	2.0	3.40	3.29	H318	AH318X	KM20	0.23	2.93	4.24	2.80
	100	150	2.0	4.70	4.57	H2318	AH3218X	KM20	0.33	2.00	3.00	2.00
	103	176	2.5	8.50	8.40	H2318	AH2318X	KM20	0.37	1.80	2.60	1.70
	103	176	2.5	8.80	8.60	H2318	AH2318X	KM20	0.37	1.80	2.60	1.70
95	107	158	2.0	4.17	4.08	H319	AH319X	KM21	0.23	2.91	4.20	2.77
	107	158	2.0	4.01	4.00	H319	AH319X	KM21	0.26	2.60	3.70	2.50
	107	158	2.0	4.40	4.30	H319	AH319X	KM21	0.27	2.50	3.60	2.40
	109	186	2.5	10.30	10.10	H2319	AH2319X	KM21	0.37	1.80	2.70	1.80

H

Double Row Spherical Roller Bearings

d = 100 to 150 mm

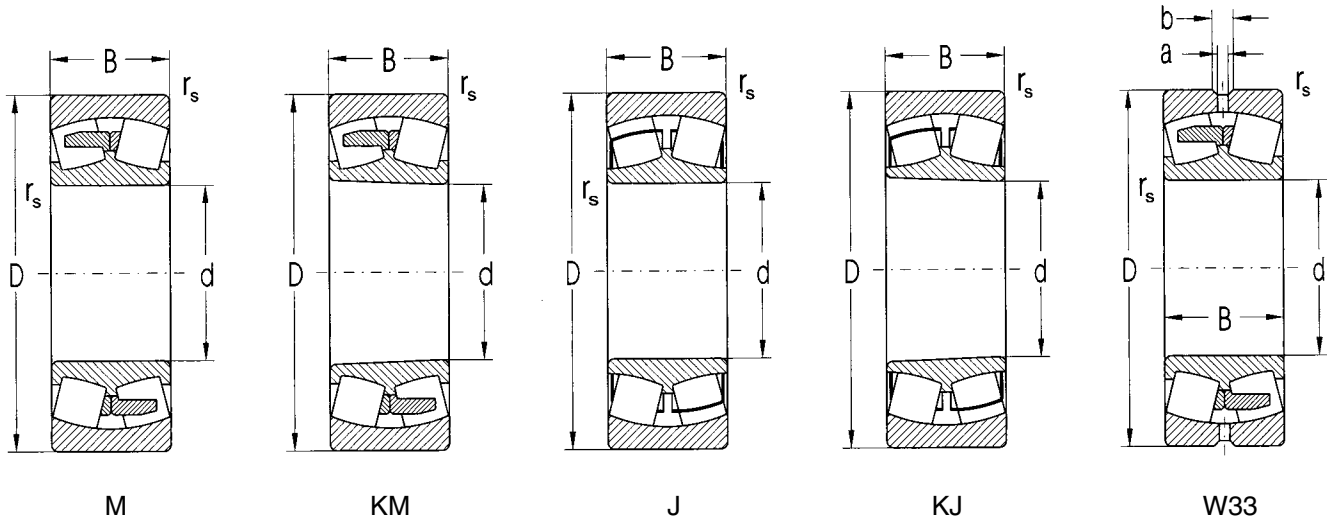

H

Dimension					Basic Load Rating				Limiting Speed for Lubrication with		Bearing Designation		
d	D	B	r _s min	a	b	Dynamic C _r	Static C _{0r}	Dynamic C _r	Static C _{0r}	Grease	Oil	with Cylindrical Bore	with Tapered Bore
mm					kN	kN	lbs.	lbs.	rpm				
100	150	37	2.0	4.5	8.3	190	294	42,714	66,094	2,400	3,200	23020M	
	180	46	2.1	4.5	8.3	306	397	68,792	89,249	2,200	3,000	22220J	22220KJ
	180	46	2.1	4.5	8.3	368	490	82,730	110,156	2,200	2,800	22220CJ	22220CKJ
	180	46	2.1	4.5	8.3	379	510	85,203	114,653	2,200	3,000	22220EW33J	22220EKW33J
	180	46	2.1	4.5	8.3	311	409	69,916	91,947	2,200	3,000	22220M	22220KM
	180	60.3	2.1	4.5	8.3	417	580	93,745	130,389	1,700	2,200	23220M	23220KM
110	170	45	2.0	4.5	8.3	267	407	60,024	91,497	2,200	3,000	23022M	23022KM
	180	56	2.0	4.5	8.3	393	609	88,350	136,909	1,900	2,600	23122CJ	23122CKJ
	180	56	2.0	4.5	8.3	379	590	85,203	132,637	1,900	2,600	23122M	23122KM
	200	53	2.1	4.5	8.3	488	653	109,707	146,800	2,000	2,800	22222EW33J	22222EKW33J
	200	53	2.1	4.5	8.3	399	531	89,699	119,374	2,000	2,800	22222J	22222KJ
	200	53	2.1	4.5	8.3	389	514	87,451	115,552	2,000	2,800	22222M	22222KM
120	200	70	2.1	4.5	8.3	530	757	119,149	170,180	1,600	2,000	23222M	23222KM
	240	80	3.0	6.0	11.1	691	846	155,343	190,188	1,500	1,900	22322M	22322KM
	180	46	2.0	3.0	5.5	322	542	72,388	121,846	2,000	2,800	23024J	23024KJ
	180	46	2.0	3.0	5.5	308	512	69,241	115,102	2,000	2,800	23024M	23024KM
	200	62	2.0	4.5	8.3	454	695	102,063	156,242	1,800	2,400	23124M	23124KM
	215	58	2.1	6.0	11.1	553	775	124,319	174,227	1,900	2,600	22224EW33J	22224EKW33J
130	215	58	2.1	6.0	11.1	468	630	105,211	141,630	1,900	2,600	22224J	22224KJ
	215	58	2.1	6.0	11.1	461	618	103,637	138,932	1,900	2,600	22224M	22224KM
	215	76	2.1	6.0	11.1	594	858	133,537	192,886	1,500	1,900	23224M	23224KM
	260	86	3.0	6.0	11.1	808	1,003	181,646	225,483	1,400	1,700	22324J	22324KJ
	260	86	3.0	6.0	11.1	812	1,009	182,545	226,832	1,400	1,800	22324M	22324KM
	140	200	52	2.0	3.0	5.5	365	575	82,055	129,265	1,900	2,600	23026J
200		52	2.0	3.0	5.5	393	633	88,350	142,304	1,900	2,600	23026M	23026KM
210		64	2.0	4.5	8.3	499	804	112,180	180,746	1,700	2,200	23126M	23126KM
230		64	3.0	6.0	11.1	641	948	144,103	213,119	1,800	2,400	22226EW33J	22226EKW33J
230		64	3.0	6.0	11.1	548	768	123,195	172,653	1,800	2,400	22226M	22226KM
230		80	3.0	6.0	11.1	666	1,004	149,723	225,708	1,300	1,700	23226M	23226KM
150	280	93	4.0	7.5	13.9	928	1,164	208,623	261,678	1,300	1,700	22326M	22326KM
	210	53	2.0	4.5	8.3	406	690	91,272	155,118	1,800	2,400	23028M	23028KM
	225	68	2.1	6.0	11.1	567	921	127,467	207,049	1,600	2,000	23128M	23128KM
	250	68	3.0	6.0	11.1	747	1,078	167,932	242,344	1,700	2,200	22228EW33J	22228EKW33J
	250	68	3.0	6.0	11.1	636	876	142,978	196,933	1,700	2,200	22228M	22228KM
	250	88	3.0	7.5	13.9	790	1,169	177,599	262,802	1,200	1,600	23228M	23228KM
150	250	88	3.0	7.5	13.9	852	1,215	191,537	273,143	1,200	1,600	23228CM	23228CKM
	300	102	4.0	9.0	16.7	1,032	1,332	232,003	299,446	1,100	1,500	22328M	22328KM
	225	56	2.1	4.5	8.3	442	748	99,366	168,157	1,700	2,200	23030M	23030KM
	250	80	2.1	4.5	8.3	738	1,180	165,909	265,275	1,400	1,800	23130M	23130KM
	270	73	3.0	7.5	13.9	863	1,260	194,010	283,259	1,600	2,000	22230EW33J	22230EKW33J
	270	73	3.0	7.5	13.9	703	982	158,041	220,762	1,600	2,000	22230M	22230KM
150	270	96	3.0	7.5	13.9	901	1,353	202,553	304,167	1,100	1,500	23230M	23230KM
	270	96	3.0	7.5	13.9	915	1,460	205,700	328,221	1,100	1,500	23230CM	23230CKM
	320	108	4.0	9.0	16.7	1,143	1,548	256,957	348,004	1,000	1,400	22330M	22330KM
	320	108	4.0	9.0	16.7	1,187	1,611	266,848	362,167	1,000	1,400	22330CM	22330CKM

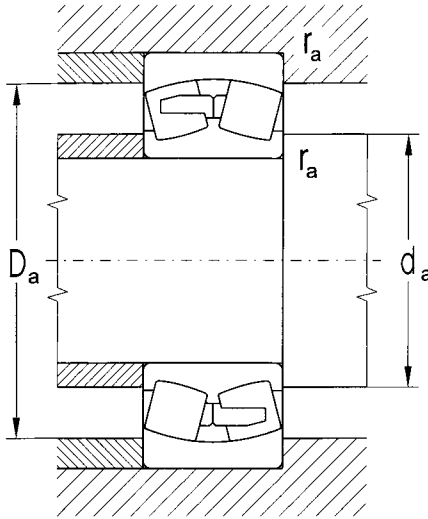

Abutment and Fillet Dimensions				Weight		Corresp. Adapter Sleeve	Corresp. Withdrawal Sleeve	Corresp. Nut	Factors			
d	d_a min	D_a max	r_a max		K				e	γ_1	γ_2	γ_0
mm				kg								
100	115	135	2.0	2.60	-	-	-	-	0.24	2.80	4.00	2.60
	112	168	2.0	5.00	4.90	H320	AH320X	KM22	0.27	2.60	3.70	2.40
	112	168	2.0	5.00	5.10	H320	AH320X	KM22	0.24	2.80	4.20	2.80
	112	168	2.0	5.01	4.90	H320	AH320X	KM22	0.24	2.87	4.14	2.73
	112	168	2.0	5.30	5.20	H320	AH320X	KM22	0.27	2.50	3.50	2.30
	112	168	2.0	6.90	6.70	H2320	AH3220X	KM22	0.35	1.90	2.90	1.90
	113	201	2.5	13.00	12.70	H2320	AH2320X	KM22	0.37	1.80	2.60	1.70
110	125	152	2.0	3.75	3.70	H322	AH3022X	KM22	0.26	2.60	3.70	2.50
	120	170	2.0	6.00	5.32	H3122	AH3122X	KM24	0.31	2.20	3.20	2.10
	120	170	2.0	6.00	5.80	H3122	AH3122X	KM24	0.31	2.20	3.10	2.00
	122	188	2.0	7.09	6.94	H322	AH3122X	KM24	0.25	2.74	3.96	2.61
	122	188	2.0	7.20	7.00	H322	AH3122X	KM24	0.28	2.40	3.50	2.30
	122	188	2.0	7.50	7.40	H322	AH3122X	KM24	0.28	2.40	3.50	2.30
	122	188	2.0	9.90	9.62	H2322	AH3222X	KM25	0.36	1.90	2.70	1.80
	124	226	2.5	18.20	17.90	H2322	AH2322X	KM25	0.37	1.80	2.60	1.70
120	128	171	2.0	3.90	3.80	H3024	AH3024X	KM26	0.25	2.70	3.90	2.60
	128	171	2.0	4.30	4.20	H3024	AH3024X	KM26	0.25	2.70	3.90	2.60
	130	190	2.0	8.20	8.00	H3124	AH3124X	KM26	0.32	2.10	3.10	2.00
	132	203	2.0	8.96	8.76	H3124	AH3124X	KM26	0.25	2.69	3.88	2.56
	132	203	2.0	8.90	8.70	H3124	AH3124X	KM26	0.29	2.40	3.40	2.30
	132	203	2.0	9.40	9.20	H3124	AH3124X	KM26	0.29	2.40	3.50	2.30
	132	203	2.0	12.30	11.90	H2324	AH3224X	KM27	0.36	1.90	2.70	1.80
	134	246	2.5	21.90	21.40	H2324	AH2324X	KM27	0.36	1.90	2.80	1.70
	134	246	2.5	22.10	21.60	H2324	AH2324X	KM27	0.36	1.90	2.70	1.70
	130	138	191	2.0	5.74	5.56	H3026	AH3026X	KM28	0.26	2.60	3.80
138		191	2.0	6.30	6.12	H3026	AH3026X	KM28	0.25	2.60	3.80	2.50
140		200	2.0	9.10	8.82	H3126	AH3126X	KM28	0.30	2.20	3.10	2.10
144		216	2.5	11.20	11.00	H3126	AH3126X	KM28	0.26	2.62	3.78	2.50
144		216	2.5	11.80	11.70	H3126	AH3126X	KM28	0.29	2.30	3.30	2.20
144		216	2.5	15.00	14.40	H2326	AH3226X	KM29	0.36	1.90	2.70	1.70
148		262	3.0	28.60	28.00	H2326	AH3226X	KM29	0.37	1.80	2.70	1.80
140	148	200	2.0	6.87	6.66	H3028	AH3028X	KM30	0.25	2.70	3.90	2.60
	152	213	2.0	10.80	10.50	H3128	AH3128X	KM30	0.30	2.20	3.20	2.10
	154	236	2.5	14.10	13.80	H3128	AH3128X	KM30	0.25	2.67	3.85	2.54
	154	236	2.5	15.00	14.60	H3128	AH3128X	KM30	0.29	2.40	3.50	2.30
	154	236	2.5	19.20	18.60	H2328	AH3228X	KM31	0.36	1.90	2.70	1.80
	154	236	2.5	18.60	18.00	H2328	AH3228X	KM31	0.33	2.00	3.00	2.00
	158	282	3.0	35.60	34.80	H2328	AH3228X	KM31	0.38	1.80	2.50	1.70
	150	159	213	2.0	8.25	8.01	H3030	AH3030X	KM32	0.25	2.70	4.00
162		238	2.0	16.60	16.10	H3130	AH3130X	KM33	0.32	2.10	3.10	2.00
164		256	2.5	17.90	17.50	H3130	AH3130X	KM33	0.25	2.68	3.87	2.55
164		256	2.5	18.60	18.20	H3130	AH3130X	KM33	0.29	2.30	3.40	2.20
164		256	2.5	24.60	23.90	H2330	AH3230X	KM33	0.37	1.80	2.70	1.80
164		256	2.5	23.90	23.20	H2330	AH3230X	KM33	0.35	1.90	2.90	1.80
168		302	3.0	42.50	42.70	H2330	AH2330X	KM33	0.38	1.80	2.60	1.70
168		302	3.0	41.70	40.80	H2330	AH2330X	KM33	0.37	1.80	2.70	1.80

Double Row Spherical Roller Bearings

d = 160 to 200 mm

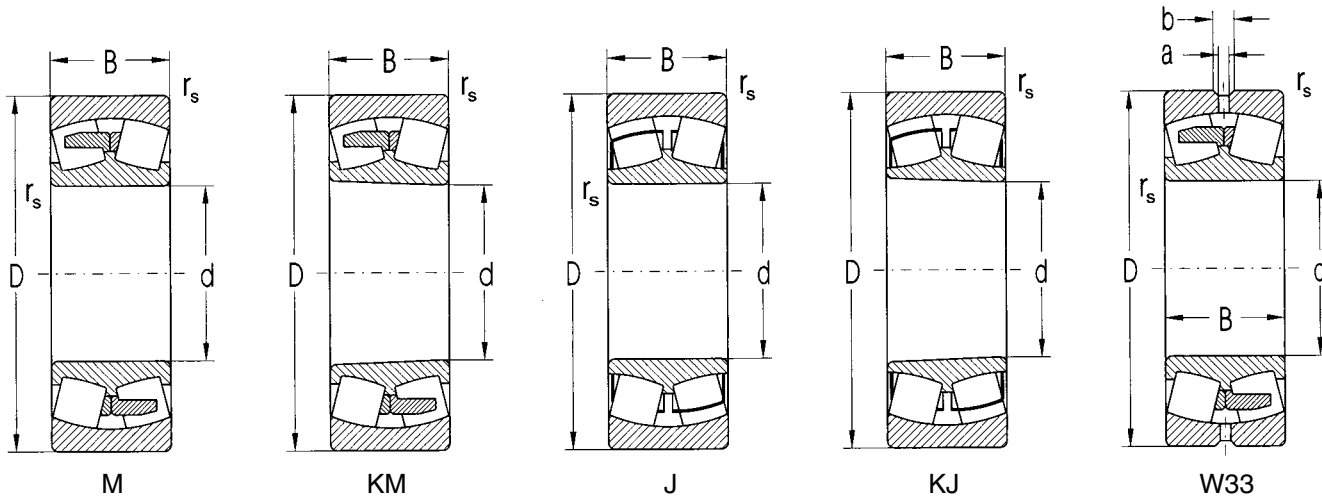

H

Dimension						Basic Load Rating				Limiting Speed for Lubrication with		Bearing Designation	
d	D	B	r _s min	a	b	Dynamic C _r	Static C _{0r}	Dynamic C _r	Static C _{0r}	Grease	Oil	with Cylindrical Bore	with Tapered Bore
mm						kN	kN	lbs.	lbs.	rpm			
160	240	60	2.1	4.5	8.3	521	903	117,125	203,002	1,700	2,200	23032M	23032KM
	270	86	2.1	6.0	11.1	817	1,307	183,669	293,825	1,300	1,700	23132M	23132KM
	290	80	3.0	7.5	13.9	978	1,442	219,863	324,174	1,500	1,900	22232EW33J	22232EKW33J
	290	80	3.0	7.5	13.9	839	1,185	188,615	266,399	1,500	1,900	22232M	22232KM
	290	104	3.0	7.5	13.9	1,134	1,830	254,933	411,400	1,000	1,400	23232CM	23232CKM
	290	104	3.0	7.5	13.9	1,100	1,169	247,290	262,802	1,000	1,300	23232M	23232KM
	340	114	4.0	9.0	16.7	1,292	1,762	290,453	396,113	960	1,300	22332M	22332KM
170	260	67	2.1	6.0	11.1	647	1,110	145,451	249,538	1,600	2,000	23034M	23034KM
	260	90	2.1	4.5	8.3	840	1,580	188,840	355,198	1,100	1,400	24034CM	24034CK30M
	280	88	2.1	6.0	11.1	858	1,420	192,886	319,229	1,200	1,600	23134M	23134KM
	310	86	4.0	7.5	13.9	944	1,352	212,220	303,942	1,300	1,700	22234M	22234KM
	310	110	4.0	7.5	13.9	1,230	1,900	276,515	427,137	940	1,200	23234M	23234KM
	310	110	4.0	7.5	13.9	1,264	1,936	284,159	435,230	950	1,300	23234CM	23234CKM
	360	120	4.0	9.0	16.7	1,450	2,053	325,973	461,533	950	1,300	22334M	22334KM
180	280	74	2.1	6.0	11.1	754	1,291	169,506	290,228	1,400	1,800	23036M	23036KM
	280	100	2.1	4.5	8.3	1,020	1,960	229,305	440,626	1,150	1,500	24036CM	24036CK30M
	300	96	3.0	6.0	11.1	996	1,620	223,910	364,190	1,000	1,500	23136M	23136KM
	300	118	4.0	6.0	11.1	1,250	2,400	281,011	539,541	700	800	24136CJ	24136CKJ
	320	86	4.0	9.0	16.7	966	1,427	217,165	320,802	1,000	1,300	22236M	22236KM
	320	112	4.0	7.5	13.9	1,346	2,173	302,593	488,510	900	1,200	23236M	23236KM
	320	112	4.0	7.5	13.9	1,360	2,110	305,740	474,347	890	1,100	23236CM	23236CKM
	380	126	4.0	12.0	22.3	1,583	2,200	355,873	494,580	900	1,200	22336M	22336KM
190	290	75	2.1	6.0	11.1	788	1,376	177,149	309,337	1,300	1,700	23038M	23038KM
	290	100	2.1	4.5	8.3	1,070	2,060	240,546	463,106	1,100	1,400	24038CM	24038CK30M
	320	104	3.0	7.5	13.9	1,170	1,930	263,026	433,881	1,000	1,400	23138M	23138KM
	340	92	4.0	9.0	16.7	1,067	1,601	239,871	359,919	1,200	1,600	22238M	22238KM
	340	120	4.0	9.0	16.7	1,460	2,360	328,221	530,549	840	1,000	23238M	23238KM
	340	120	4.0	9.0	16.7	1,547	2,510	347,779	564,270	850	1,100	23238CM	23238CKM
	400	132	5.0	12.0	22.3	1,750	2,545	393,416	572,139	840	1,000	22338M	22338KM
	400	132	5.0	12.0	22.3	1,834	2,667	412,300	599,565	850	1,100	22338CM	22338CKM
200	310	82	2.1	6.0	11.1	903	1,596	203,002	358,795	1,200	1,600	23040CM	23040CKM
	310	109	2.1	6.0	11.1	1,205	2,150	270,895	483,339	1,050	1,300	24040CM	24040CK30M
	340	112	3.0	9.0	16.7	1,284	2,105	288,655	473,223	950	1,300	23140M	23140KM
	360	98	4.0	9.0	16.7	1,192	1,810	267,972	406,904	1,100	1,500	22240M	22240KM
	360	128	4.0	9.0	16.7	1,620	2,560	364,190	575,511	790	940	23240M	23240KM
	360	128	4.0	9.0	16.7	1,693	2,858	380,602	642,504	850	1,100	23240CM	23240CKM
	420	138	5.0	12.0	22.3	1,878	2,750	422,191	618,225	850	1,100	22340M	22340KM

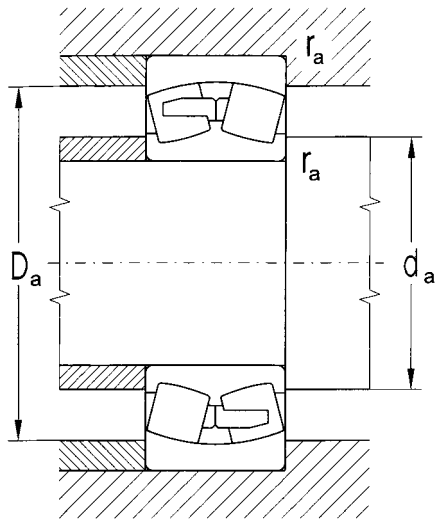

Abutment and Fillet Dimensions				Weight		Corresp. Adapter Sleeve	Corresp. Withdrawal Sleeve	Corresp. Nut	Factors			
d	d _a min	D _a max	r _a max		K				e	Y ₁	Y ₂	Y ₀
mm				kg								
160	169	228	2.0	10.3	10.0	H3032	AH3032	KM34	0.24	2.80	4.10	2.70
	172	258	2.0	21.3	20.7	H3132	AH3132	KM36	0.32	2.10	3.10	2.00
	174	276	2.5	22.7	22.2	H3132	AH3132	KM36	0.26	2.62	3.78	2.50
	174	276	2.5	24.4	23.9	H3132	AH3132	KM36	0.30	2.30	3.30	2.20
	174	276	2.5	31.0	30.1	H2332	AH3232	KM36	0.36	1.90	2.80	1.80
	174	276	2.5	31.0	30.1	H2332	AH3232	KM36	0.36	1.90	2.80	1.80
	178	322	3.0	51.9	50.8	H2332	AH2332	KM36	0.38	1.80	2.60	1.70
170	179	248	2.0	13.8	13.4	H3034	AH3034	KM 36	0.25	2.70	3.80	2.60
	182	248	2.0	17.5	17.0	H24034	AH 24034	KM36	0.32	2.10	3.10	2.10
	182	268	2.0	22.8	22.2	H3134	AH3134	KM38	0.32	2.10	3.10	2.10
	188	293	3.0	30.0	29.4	H3134	AH3134	KM38	0.30	2.30	3.20	2.16
	188	292	3.0	37.7	36.7	H2334	AH3234	KM 38	0.34	2.00	3.00	2.00
	188	293	3.0	37.7	36.4	H2334	AH3234	KM38	0.37	1.90	2.80	1.80
	188	342	3.0	59.2	58.2	H2334	AH 2334	KM38	0.37	1.80	2.60	1.70
180	189	268	2.0	17.6	17.1	H3036	AH3036	KM38	0.26	2.60	3.70	2.50
	192	268	2.0	23.0	22.0	-	AH24036	KM38	0.34	2.00	2.90	1.90
	194	286	2.5	28.9	28.0	H3136	AH3136	KM40	0.32	2.10	2.90	2.00
	194	286	2.5	27.7	26.6	H3136	AH3136	KM40	0.37	1.80	2.70	1.80
	198	302	3.0	31.5	30.8	H3136	AH2236	KM40	0.29	2.40	3.50	2.30
	198	302	3.0	39.8	38.6	H2336	AH3236	KM40	0.31	2.20	3.20	2.10
	198	302	3.0	39.8	38.6	H2336	AH3236	KM40	0.36	1.90	2.80	1.90
	198	362	3.0	73.2	71.7	H2336	AH2336	KM40	0.37	1.80	2.60	1.70
190	202	278	2.0	18.8	18.3	H3038	AH3038	HML41T	0.25	2.70	3.80	2.50
	202	278	2.0	24.0	22.0	-	AH24038	KM40	0.32	2.10	3.10	2.10
	204	306	2.5	36.1	35.0	H3138	AH3138	HM42T	0.33	2.10	3.00	2.00
	208	322	3.0	38.4	37.7	H3138	AH2238	HM42T	0.29	2.30	3.30	2.20
	208	322	4.0	48.5	47.1	H2338	AH3238	HM42T	0.32	2.10	3.20	2.10
	208	322	3.0	47.7	47.1	H2338	AH3238	HM42T	0.36	1.90	2.80	1.80
	212	378	4.0	84.1	80.5	H2338	AH2338	HM42T	0.31	2.20	3.20	2.10
	212	378	4.0	84.1	82.9	H2338	AH2338	HM42T	0.36	1.90	2.80	1.90
200	212	298	2.0	23.8	23.40	H3040	AH3040	HML43T	0.25	2.70	4.00	2.70
	212	298	2.0	30.5	29.0	-	AH24040	HM42T	0.34	2.00	3.00	2.00
	214	326	2.5	44.0	42.7	H3140	AH3140	HM44T	0.33	2.00	3.00	2.00
	218	342	3.0	46.0	45.1	H3140	AH2240	HM44T	0.29	2.30	3.30	2.20
	218	342	3.0	58.4	56.7	H2340	AH3240	HM44T	0.32	2.10	3.20	2.10
	218	342	3.0	58.6	56.7	H2340	AH3240	HM44T	0.36	1.90	2.80	1.90
	218	342	3.0	58.6	56.7	H2340	AH3240	HM44T	0.36	1.90	2.80	1.90
	222	398	4.0	99.0	97.0	H2340	AH2340	HM44T	0.36	1.90	2.70	1.80

Double Row Spherical Roller Bearings

d = 220 to 340 mm

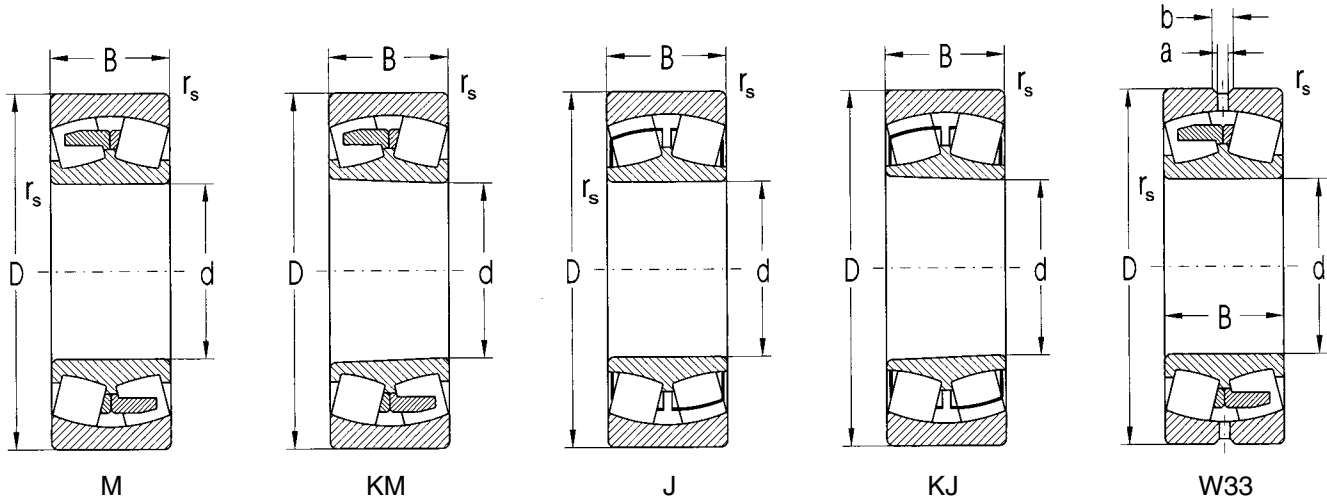

M

KM

J

KJ

W33

Dimension						Basic Load Rating				Limiting Speed for Lubrication with		Bearing Designation	
d	D	B	r _s min	a	b	Dynamic C _r	Static C _{0r}	Dynamic C _r	Static C _{0r}	Grease	Oil	with Cylindrical Bore	with Tapered Bore
mm						kN	kN	lbs.	lbs.	rpm			
220	340	90	3.0	7.5	13.9	1,032	1,895	232,003	426,013	1,100	1,500	23044CM	23044CKM
	340	90	3.0	7.5	13.9	1,095	1,950	246,166	438,377	790	940	23044M	23044KM
	340	118	3.0	6.0	11.4	1,340	2,420	301,244	544,038	900	1,200	24044CM	24044CK30M
	370	120	4.0	9.0	16.7	1,531	2,586	344,182	581,356	900	1,200	23144M	23144KM
	400	108	4.0	9.0	16.7	1,402	2,120	315,182	476,595	950	1,300	22244M	22244KM
	400	144	4.0	9.0	16.7	2,020	3,260	454,114	732,877	710	840	23244M	23244KM
	400	144	4.0	9.0	16.7	2,163	3,548	486,262	797,622	750	950	23244CM	23244CKM
460	145	5.0	12.0	22.3	2,176	3,250	489,184	730,629	750	950	22344M	22344KM	
240	360	92	3.0	7.5	13.9	1,073	1,991	241,220	447,595	1,000	1,400	23048CM	23048CKM
	360	92	3.0	7.5	13.9	1,175	2,190	264,151	492,332	750	890	23048M	23048KM
	360	118	3.0	6.0	11.1	1,500	2,990	337,213	672,179	800	1,000	24048CM	24048CK30M
	400	128	4.0	9.0	16.7	1,729	2,957	388,695	664,760	850	1,100	23148M	23148KM
	440	120	4.0	12.0	22.3	1,713	2,659	385,098	597,767	900	1,200	22248M	22248KM
	440	160	4.0	12.0	22.3	2,379	3,868	534,820	869,561	670	850	23248M	23248KM
	440	160	4.0	12.0	22.3	2,530	4,300	568,767	966,678	670	850	23248CM	23248CKM
500	155	5.0	12.0	22.3	2,511	3,830	564,495	861,018	670	850	22348M	22348KM	
260	400	104	4.0	9.0	16.7	1,392	2,500	312,934	562,022	900	1,200	23052CM	23052CKM
	400	104	4.0	9.0	16.7	1,425	2,590	320,353	582,255	670	790	23052M	23052KM
	400	140	4.0	6.0	11.1	1,915	3,730	430,509	838,537	700	900	24052CM	24052CK30M
	440	144	4.0	9.0	16.7	2,095	3,630	470,975	816,056	630	750	23152M	23152KM
	440	144	4.0	9.0	16.7	2,196	3,817	493,680	858,096	800	1,000	23152CM	23152CKM
	480	130	5.0	12.0	22.3	1,996	3,141	448,719	706,125	850	1,100	22252M	22252KM
	480	174	5.0	12.0	22.3	2,797	4,614	628,791	1,037,268	630	800	23252M	23252CKM
540	165	6.0	12.0	22.3	2,790	4,289	627,217	964,206	630	800	22352M	22352KM	
280	380	75	2.1	6.0	11.1	840	1,900	188,840	427,137	670	790	23956M	23956KM
	420	106	4.0	9.0	16.7	1,485	2,803	333,841	630,139	850	1,100	23056M	23056KM
	420	140	4.0	6.0	11.1	2,080	3,650	467,603	820,553	700	900	24056CM	24056CK30M
	460	146	5.0	9.0	16.7	2,237	4,035	502,898	907,104	750	950	23156M	23156KM
	500	130	5.0	12.0	22.3	2,066	3,315	464,455	745,242	800	1,000	22256M	22256KM
	500	176	5.0	12.0	22.3	2,915	4,958	655,318	1,114,603	600	750	23256M	23256KM
	580	175	6.0	12.0	22.3	3,138	4,886	705,450	1,098,416	560	670	22356M	22356KM
580	175	6.0	12.0	22.3	3,429	5,182	770,870	1,164,960	600	750	22356CM	22356CKM	
300	460	118	4.0	9.0	16.7	1,827	3,340	410,726	750,862	800	1,000	23060M	23060KM
	500	160	5.0	12.0	22.3	2,632	4,645	591,697	1,044,238	670	850	23160M	23160KM
	540	140	5.0	12.0	22.3	2,412	3,933	542,239	884,174	750	950	22260M	22260KM
	540	192	5.0	12.0	22.3	3,416	5,712	767,947	1,284,109	530	670	23260M	23260KM
320	480	121	4.0	9.0	16.7	1,935	3,621	435,005	814,033	800	1,000	23064M	23064KM
	540	176	5.0	12.0	22.3	3,101	5,571	697,133	1,252,411	630	800	23164M	23164KM
	580	150	5.0	12.0	22.3	2,718	4,467	611,031	1,004,222	670	850	22264M	22264KM
	580	208	5.0	12.0	22.3	3,956	6,694	889,344	1,504,871	500	630	23264M	23264KM
340	520	133	5.0	12.0	22.3	2,321	4,330	521,782	973,423	700	900	23068M	23068KM
	520	180	5.0	9.0	16.7	3,055	6,135	686,791	1,379,203	560	700	24068CM	24068CK30M
	580	190	5.0	12.0	22.3	3,507	6,229	788,405	1,400,335	600	750	23168M	23168KM
	620	224	6.0	12.0	22.3	4,526	7,768	1,017,485	1,746,316	430	530	23268M	23268KM

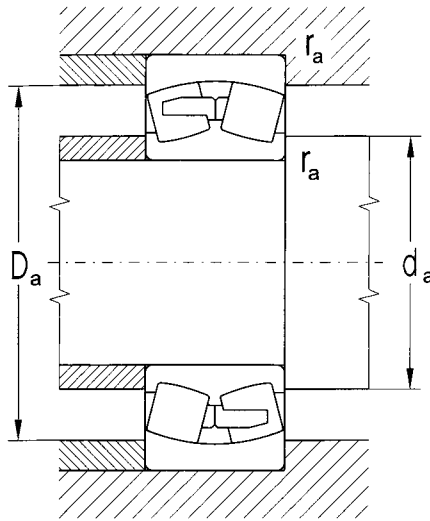

H

Abutment and Fillet Dimensions				Weight		Corresp. Adapter Sleeve	Corresp. Withdrawal Sleeve	Corresp. Nut	Factors			
d	d _a min	D _a max	r _a max		K				e	Y ₁	Y ₂	Y ₀
mm				kg								
220	234	326	2.5	26.60	25.70	H3044	AH3044	HML47T	0.26	2.6	3.9	2.50
	234	326	2.5	31.50	31.10	H3044	AH3044	HML47T	0.26	2.6	3.8	2.50
	234	326	2.5	39.00	38.10	-	AH24044	HM46T	0.33	2.1	3.1	2.00
	238	352	3.0	56.80	55.20	H3144	AH3144	HM48T	0.33	2.0	3.0	2.00
	238	382	3.0	63.00	61.00	H3144	AH2244	HM48T	0.29	2.4	3.4	2.20
	238	382	3.0	82.00	79.60	H2344	AH2344	HM48T	0.37	1.8	2.6	1.70
	238	382	3.0	83.00	79.00	H2344	AH2344	HM48T	0.37	1.9	2.6	1.70
	242	438	4.0	125.00	122.00	H2344	AH2344	HM48T	0.35	1.9	2.8	1.80
240	254	346	2.5	28.90	27.80	H3048	AH3048	HML52T	0.25	2.8	4.2	2.80
	254	346	2.5	35.50	35.40	H3048	AH3048	HML52T	0.25	2.7	4.1	2.60
	254	346	2.5	42.50	41.00	-	AH24048	HM50T	0.33	2.1	3.1	2.00
	258	382	3.0	68.70	66.70	H3148	AH3148	HM52T	0.32	2.1	3.0	1.90
	258	422	3.0	85.00	83.20	H3148	AH2248	HM52T	0.29	2.3	3.4	2.30
	258	422	3.0	113.00	110.00	H2348	AH2348	HM52T	0.38	1.8	2.5	1.70
	258	422	3.0	111.50	108.00	H2348	AH2348	HM52T	0.34	2.0	2.9	1.80
	262	478	4.0	159.00	156.00	H2348	AH2348	HM52T	0.34	1.9	2.8	1.80
260	278	382	3.0	37.50	36.10	H3052	AH3052	HML56T	0.25	2.7	4.0	2.70
	278	382	3.0	50.70	49.20	H3052	AH3052	HML56T	0.25	2.5	3.9	2.60
	278	382	3.0	64.50	63.00	-	AH24052	HM54T	0.35	1.9	2.9	1.90
	278	422	3.0	93.60	90.80	H3152	AH3152	HM58T	0.33	2.0	2.9	1.90
	278	422	3.0	90.50	87.80	H3152	AH3152	HM58T	0.33	2.0	3.1	2.00
	282	458	4.0	111.00	109.00	H3152	AH2252	HM58T	0.29	2.3	3.3	2.20
	282	458	4.0	147.00	142.00	H2352	AH2352	HM58T	0.38	1.8	2.6	1.70
	288	512	5.0	196.00	192.00	H2352	AH2352	HM58T	0.34	2.0	2.9	1.90
280	292	368	2.0	26.40	-	-	-	-	0.18	3.8	5.7	3.70
	298	402	3.0	54.50	52.90	H3056	AH3056	HML60T	0.25	2.7	3.9	2.60
	298	402	3.0	68.50	67.50	-	AH24056	HM58T	0.33	2.0	3.0	2.00
	302	438	4.0	102.80	99.00	H3156	AH3156	HM62T	0.32	2.1	3.0	2.00
	302	478	4.0	119.00	116.00	H3156	AH2256	HM62T	0.28	2.4	3.5	2.30
	302	478	4.0	157.00	152.00	H2356	AH2356	HM62T	0.36	1.9	2.6	1.80
	308	522	5.0	239.00	235.00	H2356	AH2356	HM62T	0.33	2.0	2.9	1.90
	308	522	5.0	227.00	223.00	H2356	AH2356	HM62T	0.31	2.0	3.2	2.10
300	318	442	3.0	75.80	73.60	H3060	AH3060	HML64T	0.25	2.7	3.8	2.50
	322	478	4.0	133.60	129.50	H3160	AH3160	HM66T	0.32	2.1	3.1	2.00
	322	518	4.0	150.00	147.00	H3160	AH2260	HM66T	0.27	2.5	3.6	2.40
	322	518	4.0	200.00	195.00	H3260	AH3260	HM66T	0.37	1.8	2.7	1.80
320	338	462	3.0	81.20	78.80	H3064	AH3064	HML69T	0.25	2.7	4.0	2.60
	342	518	4.0	175.30	170.10	H3164	AH3164	HM70T	0.33	2.0	3.0	1.90
	342	558	4.0	187.00	181.00	H3164	AH2264	HM70T	0.27	2.5	3.6	2.30
	342	558	4.0	253.00	246.00	H3264	AH3264	HM70T	0.37	1.8	2.6	1.70
340	362	498	4.0	108.00	105.00	H3068	AH3068	HML73T	0.25	2.7	3.9	2.55
	362	498	4.0	140.00	138.00	H24068	AH24068	HM3072	0.33	2.0	3.0	2.00
	362	558	4.0	208.60	202.20	H3168	AH3168	HM74T	0.33	2.0	3.0	1.90
	368	592	5.0	313.00	304.00	H3268	AH3268	HM74T	0.37	1.8	2.6	1.70

Double Row Spherical Roller Bearings

d = 360 to 850 mm

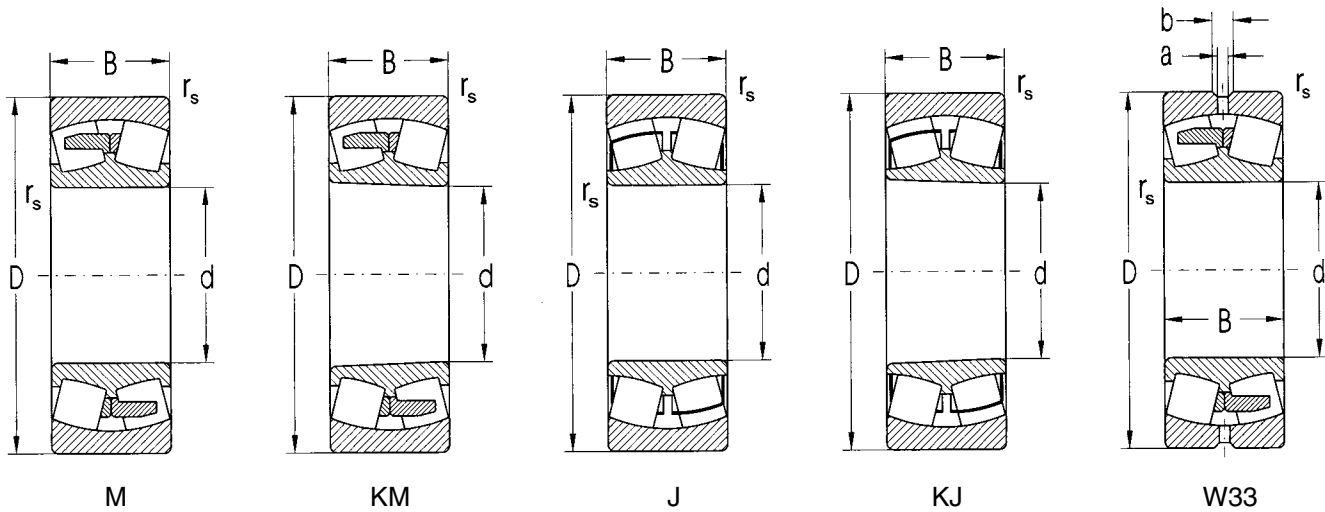

H

Dimension						Basic Load Rating				Limiting Speed for Lubrication with		Bearing Designation	
d	D	B	r _s min	a	b	Dynamic C _r	Static C _{0r}	Dynamic C _r	Static C _{0r}	Grease	Oil	with Cylindrical Bore	with Tapered Bore
mm						kN	kN	lbs.	lbs.	rpm			
360	540	134	5.0	12.0	22.3	2,411	4,577	542,014	1,028,951	670	850	23072M	23072KM
	600	192	5.0	12.0	22.3	3,681	6,683	827,522	1,502,398	560	700	23172M	23172KM
380	560	135	5.0	12.0	22.3	2,463	4,828	553,704	1,085,378	630	800	23076M	23076KM
	620	194	5.0	12.0	22.3	3,783	7,088	850,452	1,593,446	400	500	23176M	23176KM
	680	240	6.0	12.0	22.3	5,275	9,172	1,185,867	2,061,948	380	480	23276M	23276KM
400	600	148	5.0	12.0	22.3	2,926	5,648	657,791	1,269,721	600	750	23080M	23080KM
	600	200	5.0	12.0	22.3	3,735	7,790	839,661	1,751,262	450	560	24080CM	
	650	200	6.0	12.0	22.3	4,096	7,710	920,817	1,733,277	380	480	23180M	23180KM
	720	256	6.0	12.0	22.3	5,882	10,295	1,322,326	2,314,408	340	430	23280M	23280KM
420	620	150	5.0	12.0	22.3	3,008	6,002	676,225	1,349,303	450	560	23084M	23084KM
	700	224	6.0	12.0	22.3	5,019	9,591	1,128,316	2,156,143	360	450	23184CM	23184CKM
	760	272	6.0	12.0	22.3	6,520	11,175	1,465,754	2,512,240	320	400	23284CM	23284CKM
	700	224	6.0	12.0	22.3	6,400	11,300	1,438,777	2,540,341	350	420	23184M	23184KM
440	650	157	6.0	12.0	22.3	3,276	6,579	736,474	1,479,018	430	530	23088M	23088KM
	720	226	6.0	12.0	22.3	4,597	9,434	1,033,447	2,120,848	340	430	23188M	23188KM
	790	280	7.5	12.0	22.3	6,923	12,269	1,556,352	2,758,181	320	400	23288M	23288KM
460	680	163	6.0	12.0	22.3	3,556	7,184	799,421	1,615,027	400	500	23092M	23092KM
	760	240	7.5	12.0	22.3	5,806	11,164	1,305,241	2,509,767	320	400	23192M	23192KM
480	650	128	5.0	12.0	22.3	2,900	6,430	651,946	1,445,522	500	630	23996CCM	
	790	248	7.5	12.0	22.3	6,154	12,007	1,383,474	2,699,281	300	380	23196M	23196KM
	500	128	5.0	12.0	22.3	2,930	6,680	658,690	1,501,724	470	600	239/500CCM	
500	720	167	6.0	12.0	22.3	3,826	7,970	860,119	1,791,727	380	480	230/500M	230/500KM
	830	264	7.5	12.0	22.3	6,803	13,039	1,529,375	2,931,284	280	360	231/500M	231/500KM
	530	185	6.0	12.0	22.3	4,466	9,314	1,003,997	2,093,870	340	430	230/530M	230/530KM
560	820	195	6.0	12.0	22.3	5,111	10,769	1,148,999	2,420,968	300	400	230/560M	230/560KM
600	870	200	6.0	12.0	22.3	5,556	11,631	1,249,038	2,614,753	300	380	230/600CM	230/600CKM
630	920	212	7.5	12.0	22.3	6,328	13,510	1,422,591	3,037,169	260	340	230/630M	230/630KM
800	1050	258	7.5	12.0	22.3	8,630	19,680	1,940,101	4,424,240	180	260	230/800M	230/800KM
850	1200	272	7.5	12.0	22.3	9,629	22,137	2,164,685	4,976,596	160	230	230/850M	230/850KM

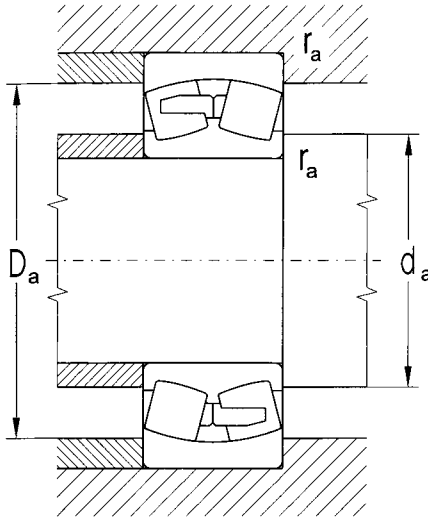

Abutment and Fillet Dimensions				Weight		Corresp. Adapter Sleeve	Corresp. Withdrawal Sleeve	Corresp. Nut	Factors			
d	d_a min	D_a max	r_a max		K				e	Y_1	Y_2	Y_0
mm				kg								
360	382	518	4.0	114.0	111.0	H3072	AH3072	HML77T	0.24	2.8	4.0	2.70
	382	578	4.0	231.6	223.8	H3172	AH3172	HM80T	0.32	2.0	3.0	2.00
380	402	538	4.0	120.0	116.5	H3076	AH3076	HML82T	0.24	2.9	4.2	2.70
	402	598	2.0	244.4	236.5	H3176	AH3176	HM84T	0.31	2.1	3.1	2.10
400	471	581	5.0	394.0	382.0	H3276	AH3276	HM84T	0.37	1.8	2.7	1.80
	422	578	5.0	156.0	152.0	H3080	AH3080	HML86T	0.24	2.8	4.0	2.70
420	422	578	5.0	205.0	-	-	-	-	0.30	2.3	3.4	2.20
	428	622	5.0	273.0	265.0	H3180	AH3180	HM88T	0.31	2.2	3.1	2.10
440	428	692	5.0	476.0	463.0	H3280	AH3280	HM88T	0.37	1.8	2.7	1.75
	442	598	4.0	164.0	159.0	H3084	AH3084	HML90T	0.24	2.9	4.3	2.80
440	448	672	5.0	362.5	348.0	H3184	AH3184	HM92T	0.32	2.1	3.2	2.00
	525	649	5.0	535.0	520.0	H3284	AH3284	HM92T	0.36	1.7	2.7	1.80
440	448	672	5.0	361.0	350.0	H3184	AH3184	HM92T	0.32	2.1	3.0	2.00
	468	622	5.0	188.0	182.0	H3088	AH3088X	HML94T	0.24	2.9	4.1	2.70
460	468	692	5.0	390.2	378.7	H3188	AH3188X	HM96T	0.31	2.1	3.1	2.00
	476	754	6.0	613.0	595.0	H3288	AH3288X	HM96T	0.37	1.8	2.7	1.80
460	488	652	5.0	213.7	207.3	H3092	AH3092X	HML98T	0.23	2.9	4.2	2.80
	496	724	6.0	456.0	441.0	H3192	AH3192X	HM102T	0.32	2.1	3.0	2.00
480	502	628	4.0	130.0	-	-	-	-	0.17	3.9	5.8	3.80
	516	754	6.0	485.0	469.0	H3196	AH3196X	HM106	0.31	2.2	3.1	2.10
500	522	648	4.0	133.0	-	-	-	-	0.17	4.0	3.9	3.90
	528	692	5.0	236.0	228.0	H30/500	AH30/500X	HML108T	0.23	3.0	4.3	2.90
530	536	794	6.0	570.0	550.0	H31/500	AH31/500X	HL110T	0.32	2.1	3.0	2.00
	558	752	5.0	322.9	313.5	H30/530	AH30/530	HML112T	0.23	3.0	4.2	2.80
560	588	792	5.0	356.7	346.0	H30/560	AH30/560	HML118T	0.23	3.0	4.2	2.80
600	633	838	5.0	405.0	400.0	H30/600	AH30/600	HML126T	0.22	2.9	4.2	2.80
630	666	884	6.0	485.0	470.0	H30/630	AH30/630	HM30/630	0.22	3.0	4.5	2.90
800	836	1114	6.0	939.0	911.0	H30/800	AH30/800	HM30/800	0.22	3.1	4.5	3.00
850	886	1184	6.0	1110.0	1080.0	H30/850	AH30/850	HML180T	0.22	3.1	4.5	3.00

Double Row Spherical Roller Bearings for Special Applications

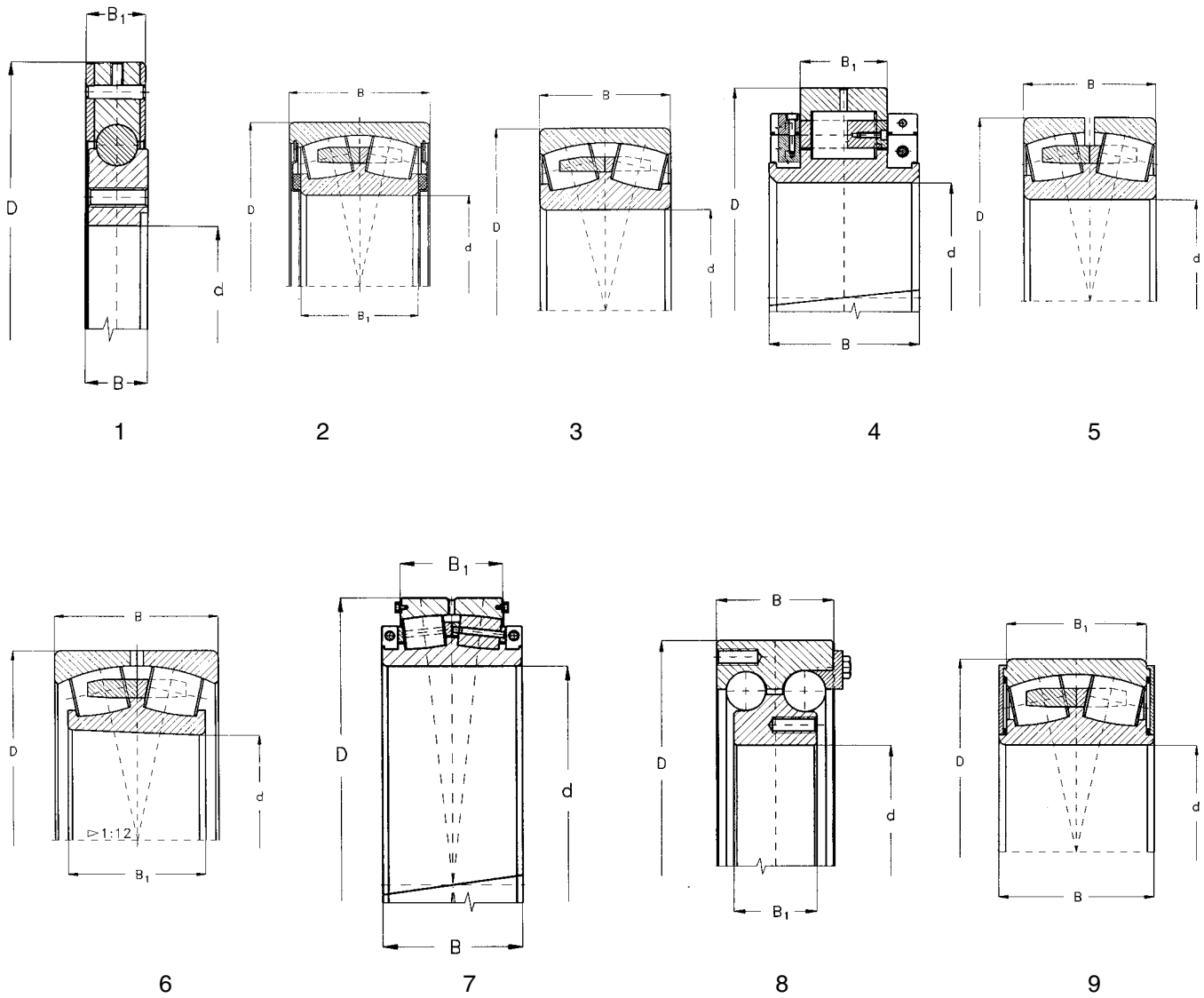

H

Designation	Dimension				Basic Load Rating				Weight	Coefficients				Figure
	d	D	B	B ₁	Dynamic C _r	Static C _{0r}	Dynamic C _r	Static C _{0r}		e	Y ₁	Y ₂	Y ₀	
	mm				kN	kN	lbs.	lbs.						
KL 761	559.0	761.00	38.2	-	232	425	52,156	95,544	51.30	-	-	-	-	1
PLC 58-2	65.0	158.80	70.0	48.0	212	250	47,659	56,202	7.36	0.38	1.8	2.6	1.7	2
PLC 59-7	130.0	220.00	73.0	-	570	1,080	128,141	242,794	12.20	0.32	2.1	3.1	2.1	3
PLC 412-7	240.0	440.07	156.0	90.5	1,248	1,920	280,562	431,633	92.00	-	-	-	-	4
PLC 510-9	130.0	225.00	80.0	-	570	1,080	128,141	242,794	12.20	0.32	2.1	3.1	2.1	5
PLC 512-5	440.0	720.00	270.0	226.0	4,300	9,000	966,678	2,023,280	389.00	0.26	2.6	3.8	2.5	6
PLC 512-28	950.0	1250.00	300.0	220.0	6,400	20,000	1,438,777	4,496,179	987.00	0.16	4.2	6.2	4.0	7
WSL 4084L	860.5	1014.80	85.0	60.0	600	3,450	134,885	775,591	118.00	-	-	-	-	8
WSL 4134L	90.0	220.00	118.0	93.0	785	950	176,475	213,568	23.00	-	-	-	-	9

Spherical Roller Bearings for Shaker Screens and Other Vibratory Equipment

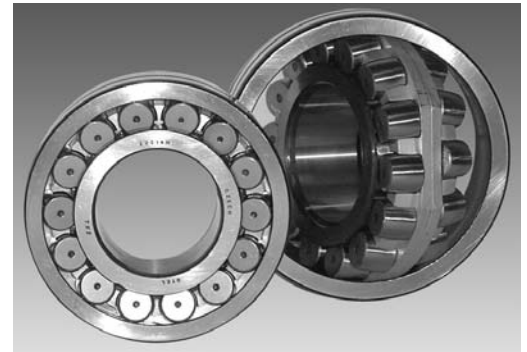

The following bearings are designed for shaker screens or other vibratory equipment applications. The bearings have special design features that allow them to withstand rough operating conditions. They are used in vibratory machines, shaker screens and grates, vibratory belts, reversing appliances, traction machines, and many other applications.

These bearings are produced with a radial clearance range of C4. A higher radial clearance allows the bearings to run cooler. Larger sizes have asymmetrical rollers, which allow for larger contact angles, minimum roller skewing and a true rolling motion. The smaller sizes are produced with symmetrical rollers, which allow for an extra load capacity design. Each bearing is produced with either a one-piece or two-piece outer ring riding brass cage. These cage designs allow for optimum lubrication and a cooler running temperature. The designation to indicate the design of the bearing is:

- MD1 - double row spherical roller bearing designed for special vibratory equipment application with two-piece outer ring riding brass cage
- MHD1 - double row spherical roller bearing designed for special vibratory equipment application with one-piece outer ring riding brass cage

Additionally, the bearings are heat stabilized for an operating temperature of 392°F. These design features create a bearing with increased dynamic and static load ratings which improve the life of the bearing.

Spherical Roller Bearings for Shaker Screens and Other Vibratory Equipment

d = 40 to 180 mm

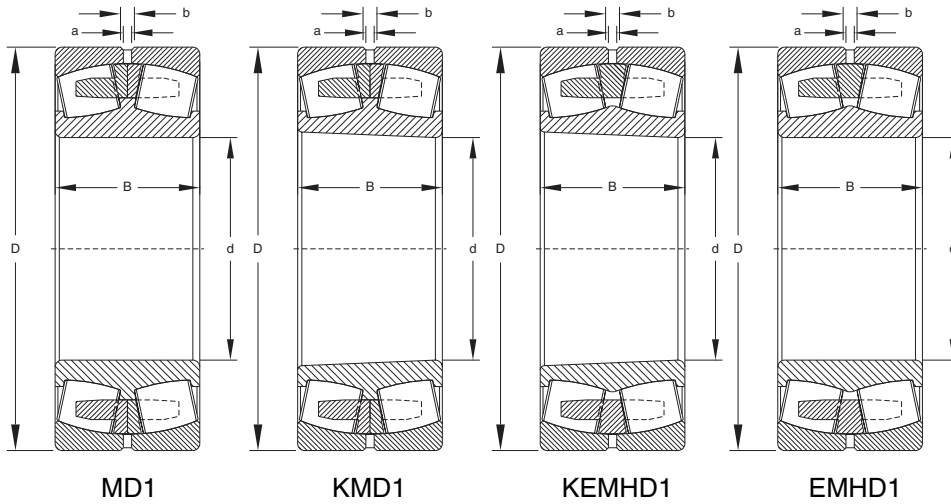

Dimension						Basic Load Rating				Limiting Speed for Lubrication with		Bearing Designation	
d	D	B	r_s min	a	b	Dynamic C_r	Static C_{or}	Dynamic C_r	Static C_{or}	Grease	Oil	with Cylindrical Bore	with Tapered Bore
mm						kN	kN	lbs.	lbs.	rpm			
40	90	33	1.5	3.0	5.5	140	160	31,473	35,969	4,500	5,600	22308EMHD1	22308EKMD1
50	110	40	2	3.0	5.5	200	238	44,962	53,505	3,400	4,300	22310EMHD1	22310EKMD1
55	120	43	2	3.0	5.5	230	279	51,706	62,722	3,200	4,000	22311EMHD1	22311EKMD1
60	130	46	2.1	3.0	5.5	226	254	50,807	57,101	2,800	3,600	22312MD1	22312KMD1
65	140	48	2.1	3.0	5.5	240	279	53,954	62,722	2,600	3,400	22313MD1	22313KMD1
70	150	51	2.1	3.0	5.5	309	360	69,466	80,931	2,400	3,000	22314MD1	22314KMD1
75	160	55	2.1	4.5	8.3	318	390	71,489	87,675	2,200	3,000	22315MD1	22315KMD1
80	170	58	2.1	4.5	8.3	373	447	83,854	100,490	2,000	2,800	22316MD1	22316KMD1
85	180	60	3	4.5	8.3	399	481	89,699	108,133	1,900	2,600	22317MD1	22317KMD1
90	190	64	3	4.5	8.3	461	559	103,637	125,668	1,800	2,400	22318MD1	22318KMD1
95	200	67	3	4.5	8.3	502	611	112,854	137,358	1,800	2,400	22319MD1	22319KMD1
100	215	73	3	6.0	11.1	583	715	131,064	160,738	1,700	2,200	22320MD1	22320KMD1
110	240	80	3	6.0	11.1	691	846	155,343	190,188	1,500	1,900	22322MD1	22322KMD1
120	260	86	3	6.0	11.1	812	1009	182,545	226,832	1,400	1,800	22324MD1	22324KMD1
130	280	93	4	7.5	13.9	928	1164	208,623	261,678	1,300	1,700	22326MD1	22326KMD1
140	300	102	4	9.0	16.7	1032	1332	232,003	299,446	1,100	1,500	22328MD1	22328KMD1
150	320	108	4	9.0	16.7	1187	1611	266,848	362,167	1,000	1,400	22330CMD1	22330KCMD1
160	340	114	4	9.0	16.7	1292	1762	290,453	396,113	960	1,300	22332MD1	22332KMD1
170	360	120	4	9.0	16.7	1450	2053	325,973	461,533	950	1,300	22334MD1	22334KMD1
180	380	126	4	12.0	22.3	1583	2200	355,873	494,580	900	1,200	22336MD1	22336KMD1

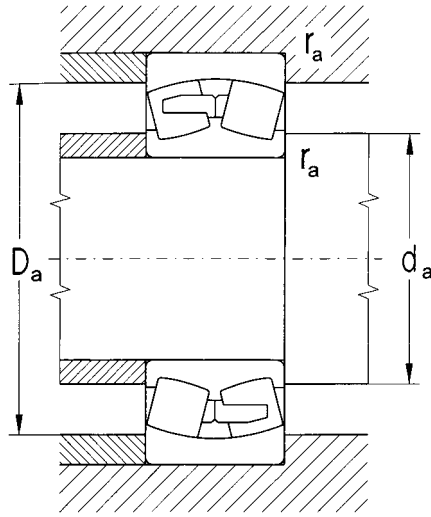

Abutment and Fillet Dimensions				Weight		Corresp. Adapter Sleeve	Corresp. Withdrawal Sleeve	Corresp. Nut	Factors			
d	d _a min	D _a max	r _a max		K				e	Y ₁	Y ₂	Y ₀
mm				kg								
40	47	81	1.5	1.07	1.05	H2308	AH2308	KM9	0.36	1.8	2.6	1.8
50	60	100	2.0	1.92	1.88	H2310	AH2310X	KM11	0.36	1.9	2.7	1.8
55	65	110	2.0	2.44	2.37	H2311	AH2311X	KM12	0.35	1.9	2.7	1.8
60	72	118	2.0	3.00	2.90	H2312	AH2312X	KM13	0.41	1.6	2.4	1.6
65	76	128	2.0	3.60	3.50	H2313	AH2313	KM15	0.38	1.8	2.5	1.7
70	81	138	2.0	4.30	4.20	H2314	AH2314X	KM16	0.37	1.8	2.6	1.7
75	86	148	2.0	5.40	5.20	H2315	AH2315X	KM17	0.38	1.8	2.5	1.7
80	91	158	2.0	6.30	6.20	H2316	AH2316X	KM18	0.36	1.8	2.7	1.8
85	98	166	2.5	7.40	7.20	H2317	AH2317X	KM19	0.36	1.9	2.7	1.8
90	100	150	2.0	8.80	8.60	H2318	AH2318X	KM20	0.37	1.8	2.6	1.7
95	109	186	2.5	10.30	10.10	H2319	AH2319	KM21	0.37	2.6	2.6	1.7
100	113	201	2.5	13.00	12.70	H2320	AH2320X	KM22	0.37	1.8	2.6	1.7
110	124	226	2.5	18.20	17.90	H2322	AH2322X	KM25	0.36	1.8	2.6	1.7
120	134	246	2.5	22.10	21.60	H2324	AH2324X	KM27	0.36	1.9	2.7	1.8
130	148	262	3.0	28.60	28.00	H2326	AH2326X	KM29	0.36	1.8	2.7	1.8
140	158	282	3.0	35.60	34.80	H2328	AH2328X	KM31	0.38	1.8	2.5	1.7
150	168	302	3.0	42.50	42.70	H2330	AH2330X	KM33	0.38	1.8	2.6	1.7
160	178	322	3.0	51.90	50.80	H2332	AH2332	KM36	0.37	1.8	2.6	1.7
170	188	342	3.0	59.20	58.20	H2334	AH2334	KM38	0.37	1.8	2.6	1.7
180	198	362	3.0	73.20	71.70	H2336	AH2336	KM40	0.37	1.8	2.6	1.7

This page left blank intentionally.

Spherical Roller Bearings for Mobile Cement Mixer Gearboxes



The following bearings are designed for use in mobile cement mixer gearboxes. The bearings are mounted onto the main shaft of the gearbox and are offered in three basic designs: PLC 58-6, PLC 59-5, and PLC 59-10, all have a wider outer ring, increasing the self-aligning ability of the bearing. These bearings are produced within ABEC 1 tolerance and have a C0 radial clearance.

The PLC 59-5 has a two-piece brass cage, which allows a higher operating temperature than other plastic cage designs. The brass cage also offers complete compatibility with all synthetic lubricants.

The PLC 59-10 also has a two-piece brass cage and offers all the same design advantages as the PLC 59-5. This bearing also has a high capacity design, which increases the dynamic and static load ratings. Both PLC 59-5 and PLC 59-10 have a two-piece split outer ring, which allows for maximum rollers and a narrower inner ring.

The PLC 58-6 has a polyamide cage, which allows the bearing to be assembled so that the outer ring does not have to be split into two pieces.

Spherical Roller Bearings for Mobile Cement Mixer Gearboxes

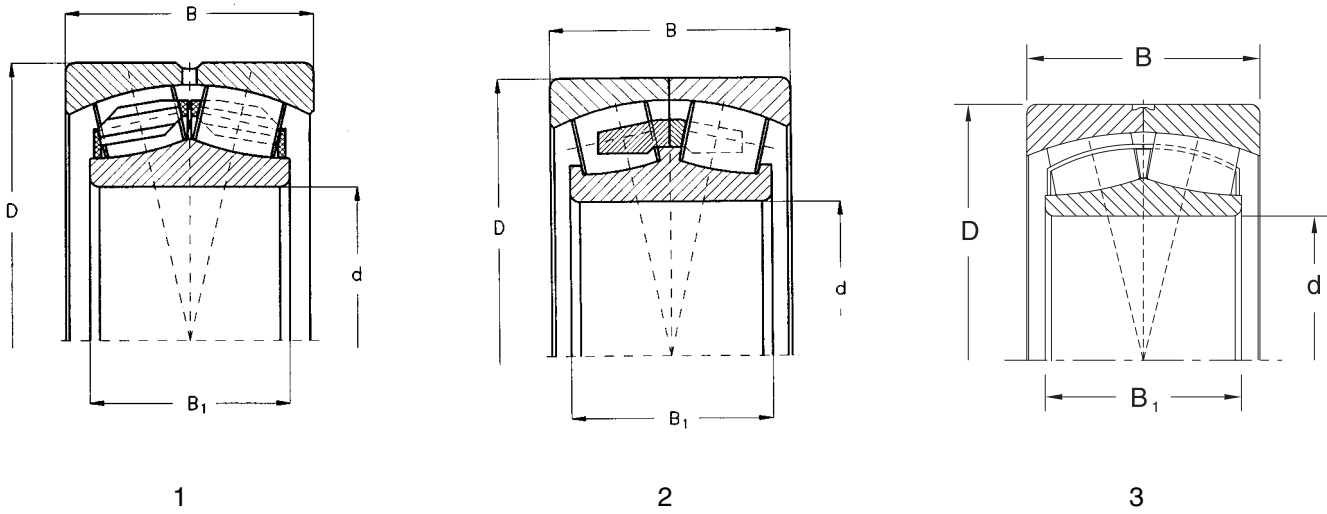

Designation	Dimension				Basic Load Rating			
	d	D	B	B ₁	Dynamic C _r	Static C _{or}	Dynamic C _r	Static C _{or}
	mm				kN	kN	lbs.	lbs.
PLC 58-6	100	150	62	50	310	550	69.691	123.645
PLC 59-5	100	180	82	69	480	710	107.908	159.614
PLC 59-10	110	180	82	69	501	849	112.629	190.863

J

Limiting Speed for		Weight	Coefficients				Figure
Grease	Oil		e	Y ₁	Y ₂	Y ₀	
rpm		kg					
2.000	2.600	3.70	0.30	2.30	3.30	2.20	1
1.400	1.800	10.30	0.42	1.67	2.42	1.60	2
1.400	1.700	8.00	0.37	1.80	2.70	1.80	3

J

This page left blank intentionally.

Spherical Plain Bearings

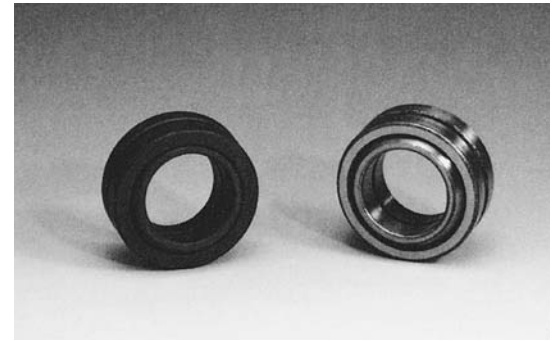

Spherical plain bearings are radial sliding bearings, consisting of one inner and one outer ring, which have spherical working surfaces. These bearings are used in applications where large radial forces are applied at a slow tilting rotation or oscillating motion. Besides radial loads, these bearings can also accommodate a certain amount of axial load in both directions. Spherical plain bearings are produced from standard bearing steel. The rings are hardened, ground or phosphatized.

Boundary Dimensions

The boundary dimensions for spherical plain bearings designation GE comply with the standard ISO 6124/1 (STN 02 3515); designation GEW complies to standard ISO 6124/2 (STN 02 3516).

Tolerance

Spherical plain bearings are produced with ABEC 1 or P0 tolerances. Values for these tolerances comply with standard ISO 6125.

Radial Clearance

Spherical plain bearings are commonly produced with normal (C0) radial clearance. Please see the chart below for specific radial clearance values.

Bore Diameter		Radial Clearance					
		C2		normal		C3	
over	to	min	max	min	max	min	max
mm		µm					
12	20	10	40	40	82	82	124
20	35	12	50	50	100	100	150
35	60	15	60	60	120	120	180

Designation

Spherical plain bearings have a designation that consists of prefix letters GE or GEW, followed by a number which indicates the bore diameter in millimeters; e.g., GE30. Other designations are used to indicate radial clearance, sealing, dimension changes, etc., by additional standard symbols. The one exception to this would be the designation E which is used to identify a phosphatized surface.

K

Spherical Plain Bearings

d = 15 to 50 mm

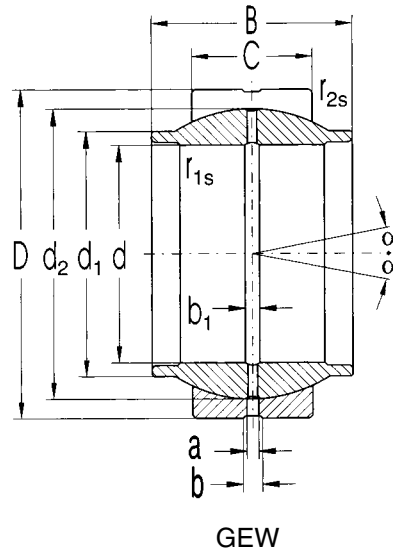
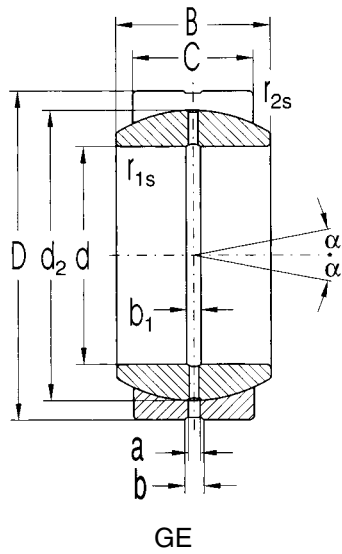

Dimension									Radial Clearance Normal		Basic Load Rating			
d	D	B	C	d ₁	d ₂	r _{1s} min	r _{2s} min	á	min	max	Dynamic C _r	Static C _{0r}	Dynamic C _r	Static C _{0r}
mm									µm		kN	kN	lbs.	lbs.
15	26	12	9	-	22	0.6	0.6	8°	40	82	17	85	3,822	19,109
20	35	16	12	-	29	0.6	0.6	9°	40	82	30	146	6,744	32,822
	35	20	12	25	29	0.6	0.6	4°	40	82	30	146	6,744	32,822
25	42	20	16	-	35.5	0.6	0.6	7°	50	100	48	240	10,791	53,954
	42	25	16	30.5	35.5	0.6	0.6	4°	50	100	48	240	10,791	53,954
30	47	22	18	-	40.7	0.6	0.6	6°	50	100	62	310	13,938	69,691
35	55	25	20	-	47	0.6	1.0	6°	50	100	80	400	17,985	89,924
40	62	28	22	-	53	0.6	1.0	7°	60	120	100	500	22,481	112,405
	62	40	22	46	53	0.6	1.0	4°	60	120	100	500	22,481	112,405
45	68	32	25	-	60	0.6	1.0	7°	60	120	127	640	28,551	143,878
50	75	35	28	-	66	0.6	1.0	6°	60	120	156	780	35,070	175,352

K

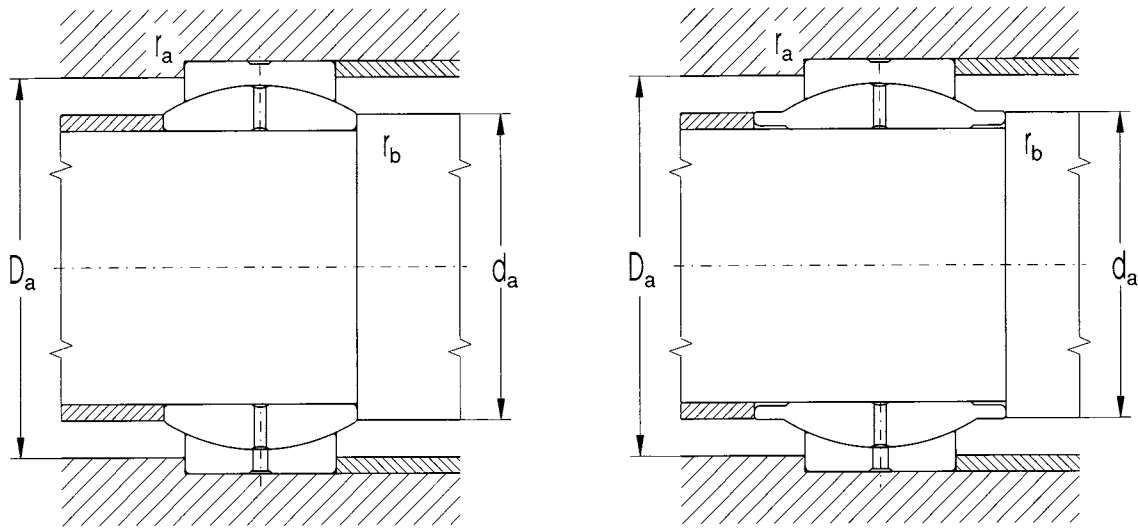

Bearing Designation	Weight	Abutment and Fillet Dimensions						
		d	d _a min	d _a max	D _a max	D _a min	r _a max	r _b max
	mm							kg
GE15E	0.025	15	18	18	23	21	0.6	0.5
GE20E	0.061	20	23	24	31	28	0.3	0.5
GEW20E	0.070		24	26	31	28	0.6	0.6
GE25E	0.110	25	28	29	36	33	0.6	0.5
GEW25E	0.120		29.5	31.5	38	33	0.6	0.6
GE30E	0.140	30	33	34	43	38	0.6	0.5
GE35E	0.220	35	39	40	50	44	0.8	0.6
GE40E	0.300	40	44	45	57	50	0.8	0.6
GEW40E	0.340		44	45	57	50	0.8	0.6
GE45E	0.400	45	49	50	63	56	0.8	0.6
GE50E	0.540	50	54	56	70	61	0.8	0.6

K

This page left blank intentionally.

Tapered Roller Bearings



ZVL-ZKL tapered roller bearings are designed for use in a wide range of applications, including the automotive, tractor, and machine tool industries, and are available in both inch and metric dimensions. This is a separable type of bearing. The inner ring (cone), along with the cage and rollers, is one assembly unit; the outer ring (cup) is the other assembly unit. This feature allows the bearings to be fitted separately and adjusted so that the optimum clearance or preload for each application is achieved.

Due to the inclined position of the tapered rollers, the contact lines between the rollers and raceways intersect at a common point on the axis of the bearing. The contact surfaces of the raceways and tapered rollers are modified to limit edge stresses. As a result of this modification and the large number of rollers, this bearing has high load-carrying capacity and is designed to carry axial and radial loads simultaneously. Since a single bearing of this type can only carry axial loads in one direction, the bearings are usually mounted in pairs.

Cage

Tapered roller bearings are produced with pressed steel cages. There are currently two designs of the steel cage, “J” and “J2” designations. The “J2” design is a newer, innovative cage design that eliminates excess material from the cage.

Boundary Dimensions

Boundary dimensions of metric single row tapered roller bearings comply with standard ISO 355. Boundary dimensions of single row tapered roller bearings in inch dimensions comply with standard AFBMA 19.

Tolerance

Tapered roller bearings are produced in standard production in accordance to ABEC 1 or P0 tolerance class. Higher tolerance classes may be produced upon request.

Internal Clearance

Tapered roller bearings are usually mounted in pairs in which required clearance or preload is adjusted at mounting. The specified clearance or preload should be determined on an application-by-application basis.

Misalignment

Tapered roller bearings can only allow a small amount of misalignment. The following conditions should apply when considering permissible misalignment:

- at small load ($F_r < 0.1 C_{or}$) 1' to 1.5'
- at great load ($F_r \geq 0.1 C_{or}$) 2' to 4'

Radial Equivalent Dynamic Load

$$P_r = F_r \quad \text{for } F_a / F_r \leq e \quad [\text{kN}]$$

$$P_r = 0.4 F_r + Y F_a \quad \text{for } F_a / F_r > e \quad [\text{kN}]$$

Values of factors e and Y for individual bearings are shown in the dimension tables.

Radial Equivalent Static Load

$$P_{or} = 0.5 F_r + Y_0 F_a \quad (P_{or} \geq F_r) \quad [\text{kN}]$$

Values of Y_0 factor for individual bearings are shown in the dimension tables.

Internal Forces of Tapered Roller Bearing Pairs

If two tapered roller bearings are assembled on a shaft to work as a pair, regular loading of those bearings will produce additional axial forces. The load magnitude for one of the bearings is dependent upon the load and contact angle of the second bearing. These additional inner forces should be taken into account. Shown below are some different bearing pair arrangements. Use the equations that match the bearing arrangement to find the appropriate loads.

Bearing Arrangement	Force Conditions	Bearing Axial Load	
		Bearing A	Bearing B
	$\frac{F_{rA}}{Y_A} \leq \frac{F_{rB}}{Y_B}$ $K_a \geq 0$	$F_{aA} = F_{aB} + K_a$	$F_{aB} = \frac{0.5 F_{rB}}{Y_B}$
	$\frac{F_{rA}}{Y_A} > \frac{F_{rB}}{Y_B}$ $K_a \geq 0.5 \left(\frac{F_{rA}}{Y_A} - \frac{F_{rB}}{Y_B} \right)$	$F_{aA} = F_{aB} + K_a$	$F_{aB} = \frac{0.5 F_{rB}}{Y_B}$
	$\frac{F_{rA}}{Y_A} > \frac{F_{rB}}{Y_B}$ $K_a < 0.5 \left(\frac{F_{rA}}{Y_A} - \frac{F_{rB}}{Y_B} \right)^1$	$F_{aA} = \frac{0.5 F_{rA}}{Y_A}$	$F_{aB} = F_{aA} - K_a$
	$\frac{F_{rA}}{Y_A} \geq \frac{F_{rB}}{Y_B}$ $K_a \geq 0$	$F_{aA} = \frac{0.5 F_{rA}}{Y_A}$	$F_{aB} = F_{aA} + K_a$
	$\frac{F_{rA}}{Y_A} < \frac{F_{rB}}{Y_B}$ $K_a \geq 0.5 \left(\frac{F_{rB}}{Y_B} - \frac{F_{rA}}{Y_A} \right)$	$F_{aA} = \frac{0.5 F_{rA}}{Y_A}$	$F_{aB} = F_{aA} + K_a$
	$\frac{F_{rA}}{Y_A} < \frac{F_{rB}}{Y_B}$ $K_a < 0.5 \left(\frac{F_{rB}}{Y_B} - \frac{F_{rA}}{Y_A} \right)^1$	$F_{aA} = F_{aB} - K_a$	$F_{aB} = \frac{0.5 F_{rB}}{Y_B}$

¹⁾ Valid for $K_a = 0$

Part Numbers

Listed in the dimension tables are the part numbers for tapered roller bearings. For most of the metric tapered roller bearings listed, you will see two part numbers. One is the industry standard part number (STN); the other part number is issued by ISO and is in compliance with standard ISO 355. The ISO part number breaks down to the following components:

T	bearing type
2, 3, 4, 5, 7	angle series of bearing
B, C, D, E, F, G	diameter series of bearing
B, C, D, E	width series of bearing
000	bore diameter in mm

Designation

Listed below are some standard designations for tapered roller bearings.

Tapered Roller Bearings		
Suffix	Description	Example of Designation
A	Internal design change for enhanced load carrying capacity	32206 A
B	Contact angle $\alpha = 17^\circ$	32309 B
J2	New pressed steel cage, eliminates excess material of cage	30210A J2
X	Altered boundary dimensions introduced by revised ISO standards	32018 X
P6	Higher tolerance class than normal	30304A P6
C6	Reduced vibration level	30205A C6
S0	Heat stabilized for an operating temperature up to 302°F (150°C)	30210A S0

Single Row Tapered Roller Bearings

d = 17 to 45 mm

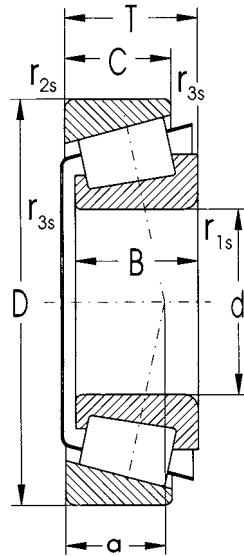

Dimension									Basic Load Rating				Limiting Speed for Lubrication with		
d	D	B	C	T	r _{1s} min	r _{2s} min	r _{3s} min	a	Dynamic C _r	Static C _{0r}	Dynamic C _r	Static C _{0r}	Grease	Oil	
mm									kN	kN	lbs.	lbs.	rpm		
17	40	12	11.0	13.25	1.0	1.0	0.3	10	16.8	16.5	3,777	3,709	11,000	15,000	
	47	14	12.0	15.25	1.0	1.0	0.3	11	25.1	22.8	5,643	5,126	10,000	13,000	
20	42	15	12.0	15.00	0.6	0.6	0.3	10	22.8	29.0	5,126	6,519	9,000	13,000	
	47	14	12.0	15.25	1.0	1.0	0.3	11	25.1	26.1	5,643	5,868	8,900	12,000	
	52	15	13.0	16.25	1.5	1.5	0.6	11	30.4	29.9	6,834	6,722	8,400	11,000	
	52	21	18.0	22.25	1.5	1.5	0.6	13	43.8	45.5	9,847	10,229	8,400	11,000	
25	47	15	11.5	15.00	0.6	0.6	0.3	12	24.2	28.7	5,440	6,452	8,400	11,000	
	52	15	13.0	16.25	1.0	1.0	0.3	12	29.9	33.5	6,722	7,531	7,500	10,000	
	62	17	15.0	18.25	1.5	1.5	0.6	13	43.8	42.1	9,847	9,464	6,900	9,200	
	62	17	15.0	18.25	1.5	1.5	0.6	13	39.8	38.3	8,947	8,610	7,100	9,400	
	62	17	13.0	18.25	1.5	1.5	0.6	20	36.2	39.1	8,138	8,790	6,700	8,900	
	62	24	20.0	25.25	1.5	1.5	0.6	15	57.3	60.7	12,882	13,646	6,700	8,900	
30	55	17	13.0	17.00	1.0	1.0	0.3	13	35.5	43.8	7,981	9,847	7,100	9,400	
	62	16	14.0	17.25	1.0	1.0	0.3	14	40.6	44.7	9,127	10,049	6,700	8,900	
	62	20	17.0	21.25	1.0	1.0	0.3	15	50.1	59.6	11,263	13,399	6,700	8,900	
	72	19	16.0	20.75	1.5	1.5	0.6	15	53.1	53.1	11,937	11,937	5,600	7,500	
	72	19	14.0	20.75	1.5	1.5	0.6	23	46.4	50.1	10,431	11,263	5,300	7,100	
	72	27	23.0	28.75	1.5	1.5	0.6	20	76.4	85.8	17,175	19,289	5,600	7,500	
32	58	17	13.0	17.00	1.0	1.0	0.3	14	39.8	48.2	8,947	10,836	7,100	9,400	
	35	62	18	14.0	18.00	1.0	1.0	0.3	15	43.0	53.1	9,667	11,937	6,300	8,400
		72	17	15.0	18.25	1.5	1.5	0.6	15	46.4	51.1	10,431	11,488	5,300	7,100
		72	23	19.0	24.25	1.5	1.5	0.6	17	64.3	76.4	14,455	17,175	5,300	7,100
		80	21	18.0	22.75	2.0	1.5	0.6	16	65.6	69.4	14,747	15,602	5,000	6,700
		80	21	15.0	22.75	2.0	1.5	0.6	26	57.3	63.1	12,882	14,185	4,700	6,300
80		31	25.0	32.75	2.0	1.5	0.6	20	94.4	110.0	21,222	24,729	4,700	6,300	
40	68	19	14.5	19.00	1.0	1.0	0.3	15	48.2	64.3	10,836	14,455	5,300	7,100	
	80	18	16.0	19.75	1.5	1.5	0.6	17	55.2	60.7	12,409	13,646	4,700	6,300	
	80	23	19.0	24.75	1.5	1.5	0.6	18	70.8	85.5	15,916	19,221	4,700	6,300	
	90	23	20.0	25.25	2.0	1.5	0.6	18	84.3	93.2	18,951	20,952	4,500	6,000	
	90	23	20.0	25.25	2.0	1.5	0.6	19	82.5	94.4	18,547	21,222	4,500	6,000	
	90	23	17.0	25.25	2.0	1.5	0.6	29	76.4	85.8	17,175	19,289	4,000	5,300	
	90	33	27.0	35.25	2.0	1.5	0.6	22	114.0	141.0	25,628	31,698	4,200	5,600	
	90	33	27.0	35.25	2.0	1.5	0.6	27	104.2	136.6	23,425	30,709	4,100	5,400	
	90	33	27.0	35.25	2.0	1.5	0.6	27	104.0	144.0	23,380	32,372	4,200	5,600	
	45	75	20	15.5	20.00	1.0	1.0	0.3	17	57.3	79.4	12,882	17,850	4,700	6,300
85		19	16.0	20.75	1.5	1.5	0.6	18	61.9	70.8	13,916	15,916	4,500	6,000	
85		23	19.0	24.75	1.5	1.5	0.6	20	73.6	90.9	16,546	20,435	4,500	6,000	
100		25	22.0	27.25	2.0	1.5	0.6	21	107.0	118.0	24,055	26,527	4,000	5,300	
100		25	22.0	27.25	2.0	1.5	0.6	21	104.0	117.0	23,380	26,303	4,000	5,300	
100		25	18.0	27.25	2.0	1.5	0.6	32	92.6	104.0	20,817	23,380	3,800	5,000	
100		36	30.0	38.25	2.0	1.5	0.6	25	144.0	181.0	32,372	40,690	3,800	5,000	
100		36	30.0	38.25	2.0	1.5	0.6	31	131.0	174.0	29,450	39,117	3,800	5,000	

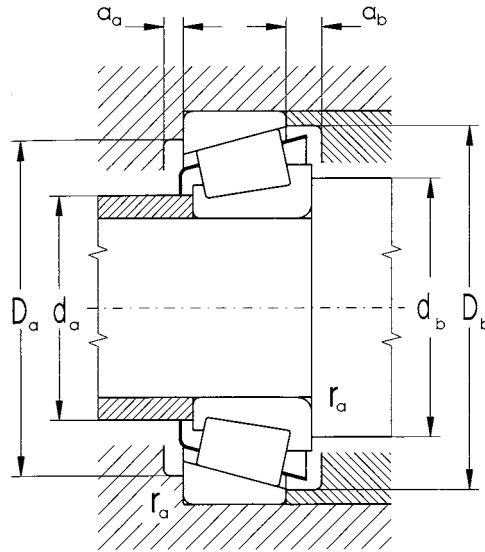

Bearing Designation		Abutment and Fillet Dimensions									Weight	Factors		
STN	ISO	d	d _a max	d _b min	D _a min	D _a max	D _b min	a _a min	a _b min	r _a max	-	e	Y	Y ₀
mm											kg			
30203A		17	23	23	34	34	37	2	2.0	1.0	0.081	0.35	1.7	1.0
30303AJ2	T2FB017		25	23	39	41	42	2	3.0	1.0	0.140	0.29	2.1	1.2
32004AX	T3CC020	20	25	25	36	37	39	3	3.0	0.6	0.102	0.37	1.6	0.9
30204AJ2			26	26	39	41	43	2	3.0	1.0	0.132	0.35	1.7	1.0
30304A	T2FB020		27	27	43	45	47	2	3.0	1.0	0.179	0.30	2.0	1.1
32304A	T2FD020		27	27	43	45	47	2	4.0	1.0	0.267	0.30	2.0	1.1
32005AX	T4CC025	25	30	31	40.5	42	44	3	3.5	0.6	0.117	0.43	1.4	0.8
30205A	T3CC025		31	31	43	46	48	2	3.0	1.0	0.167	0.37	1.6	0.9
30305A	T2FB025		33	32	53	55	57	2	3.0	1.0	0.288	0.30	2.0	1.1
30305AJ2	T2FB025		33	32	53	55	57	2	3.0	1.0	0.265	0.30	2.0	1.1
31305A	T7FB025		33	32	46	55	59	2	5.0	1.0	0.271	0.83	0.7	0.4
32305A	T2FD025		33	32	53	55	57	2	5.0	1.0	0.404	0.30	2.0	1.1
32006AX	T4CC030	30	35	36	47.5	49	52	3	4.0	1.0	0.181	0.43	1.4	0.8
30206AJ2	T3DB030		37	36	52	56	57	2	3.0	1.0	0.252	0.37	1.6	0.9
32206A	T3DC030		37	36	52	56	58.5	2	4.0	1.0	0.320	0.37	1.6	0.9
30306A	T2FB030		38	37	61	65	66	2	4.5	1.0	0.419	0.32	1.9	1.1
31306AJ2	T7FB030		39	37	55	65	68	2	6.5	1.0	0.390	0.83	0.7	0.4
32306A	T2FD030		38	37	61	65	66	2	5.5	1.0	0.628	0.32	1.9	1.1
320/32AX	T4CC032	32	38	38	50	52	55	3	4.0	1.0	0.196	0.45	1.3	0.7
32007AX	T4CC035	35	40	41	54	56	59	4	4.0	1.0	0.243	0.45	1.3	0.7
30207A	T3DB035		43	42	61	65	67	3	3.0	1.0	0.361	0.37	1.6	0.9
32207A	T3DC035		43	42	61	65	68.5	3	5.0	1.0	0.480	0.37	1.6	0.9
30307A	T2FB035		43	44	68	71	74	3	4.5	1.5	0.551	0.32	1.9	1.1
31307AJ2	T7FB035		43	44	61	71	76	3	7.5	1.5	0.520	0.83	0.7	0.4
32307A	T2FE035		43	44	68	71	74	3	7.5	1.5	0.827	0.32	1.9	1.1
32008AX	T3CD040	40	45	46	60	62	65	4	4.5	1.0	0.290	0.38	1.6	0.9
30208A	T3DB040		48	47	68	73	75.5	3	3.5	1.0	0.452	0.37	1.6	0.9
32208A	T3DC040		48	47	68	73	75	3	5.5	1.0	0.594	0.37	1.6	0.9
30308A	T2FB040		50	49	76	81	82	3	5.0	1.5	0.773	0.35	1.7	1.0
30308AJ2	T2FB040		50	49	76	81	82	3	5.0	1.5	0.773	0.35	1.7	1.0
31308A	T7FB040		50	49	70	81	86	3	8.0	1.5	0.776	0.83	0.7	0.4
32308A	T2FD040		50	49	76	81	82	3	8.0	1.5	1.120	0.35	1.7	1.0
32308BA	T5FD040		50	49	70	81	85	4	8.0	1.5	1.110	0.54	1.1	0.6
32308BAJ2	T5FD040		50	49	70	81	85	4	8.0	1.5	0.990	0.54	1.1	0.6
32009AX	T3CC045	45	50	51	66	69	72	4	4.5	1.0	0.355	0.39	1.5	0.8
30209A	T3DB045		53	52	73	78	80	3	4.5	1.0	0.527	0.41	1.5	0.8
32209A	T3DC045		53	52	73	78	81.5	3	5.5	1.0	0.641	0.41	1.5	0.8
30309A	T2FB045		56	54	85	91	92	3	5.0	1.5	1.040	0.35	1.7	1.0
30309AJ2	T2FB045		56	54	85	91	92	3	5.0	1.5	1.040	0.35	1.7	1.0
31309A	T7FB045		55	54	78	91	95	3	9.0	1.5	1.030	0.83	0.7	0.4
32309A	T2FD045		56	54	85	91	93	3	8.0	1.5	1.530	0.35	1.7	1.0
32309BAJ2	T5FD045		55	54	76	91	94	5	8.0	1.5	1.540	0.54	1.1	0.6



Single Row Tapered Roller Bearings

d = 50 to 75 mm

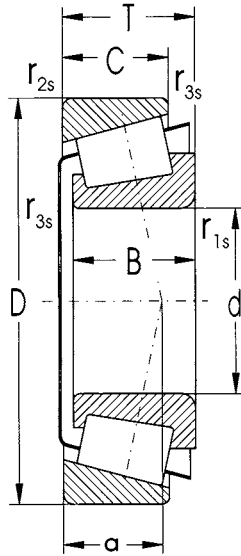

Dimension									Basic Load Rating				Limiting Speed for Lubrication with		
d	D	B	C	T	r _{1s} min	r _{2s} min	r _{3s} min	a	Dynamic C _r	Static C _{0r}	Dynamic C _r	Static C _{0r}	Grease	Oil	
mm									kN	kN	lbs.	lbs.	rpm		
50	80	20	15.5	20.00	1.0	1.0	0.3	18	59.6	87.4	13,399	19,648	4,500	6,000	
	90	20	17.0	21.75	1.5	1.5	0.6	20	70.8	87.4	15,916	19,648	4,200	5,600	
	90	23	19.0	24.75	1.5	1.5	0.6	21	81.0	102.0	18,210	22,931	4,200	5,600	
	110	27	23.0	29.25	2.5	2.0	0.6	23	121.0	141.0	27,202	31,698	3,800	5,000	
	110	27	19.0	29.25	2.5	2.0	0.6	35	102.0	114.0	22,931	25,628	3,300	4,500	
	110	40	33.0	42.25	2.5	2.0	0.6	27	174.0	224.0	39,117	50,357	3,300	4,500	
110	40	33.0	42.25	2.5	2.0	0.6	33	147.0	215.0	33,047	48,334	3,200	4,400		
	55	90	23	17.5	23.00	1.5	1.5	0.6	20	76.4	108.0	17,175	24,279	4,000	5,300
		100	21	18.0	22.75	2.0	1.5	0.6	21	81.0	96.2	18,210	21,627	3,800	5,000
		100	25	21.0	26.75	2.0	1.5	0.6	22	102.0	128.0	22,931	28,776	3,800	5,000
		120	29	25.0	31.50	2.5	2.0	0.6	25	136.0	162.0	30,574	36,419	3,300	4,500
		120	29	21.0	31.50	2.5	2.0	0.6	38	117.0	136.0	26,303	30,574	3,000	4,000
120		43	35.0	45.50	2.5	2.0	0.6	29	200.0	256.0	44,962	57,551	3,300	4,500	
60	95	23	17.5	23.00	1.5	1.5	0.6	21	81.0	119.0	18,210	26,752	3,800	5,000	
	110	22	19.0	23.75	2.0	1.5	0.6	22	94.4	117.0	21,222	26,303	3,300	4,500	
	110	28	24.0	29.75	2.0	1.5	0.6	25	126.0	162.0	28,326	36,419	3,300	4,500	
	130	31	26.0	33.50	3.0	2.5	1.0	26	162.0	188.0	36,419	42,264	3,000	4,000	
	130	31	22.0	33.50	3.0	2.5	1.0	41	136.0	158.0	30,574	35,520	2,800	3,800	
	130	46	37.0	48.50	3.0	2.5	1.0	31	228.0	299.0	51,256	67,218	2,800	3,800	
130	46	37.0	48.50	3.0	2.5	1.0	39	200.0	293.0	44,962	65,869	2,500	3,300		
	65	100	23	17.5	23.00	1.5	1.5	0.6	23	81.0	123.0	18,210	27,652	3,300	4,500
		110	34	26.5	34.00	1.5	1.5	0.6	26	136.0	207.0	30,574	46,535	3,800	5,300
		120	23	20.0	24.75	2.0	1.5	0.6	24	112.0	136.0	25,179	30,574	3,000	4,000
		120	31	27.0	32.75	2.0	1.5	0.6	28	150.0	200.0	33,721	44,962	3,000	4,000
		120	41	32.0	41.00	2.0	1.5	0.6	30	191.0	267.0	42,939	60,024	3,000	4,000
140		33	28.0	36.00	3.0	2.5	1.0	28	185.0	220.0	41,590	49,458	2,800	3,800	
140	33	23.0	36.00	3.0	2.5	1.0	44	150.0	178.0	33,721	40,016	2,800	3,800		
	140	48	39.0	51.00	3.0	2.5	1.0	33	261.0	331.0	58,675	74,412	2,800	3,800	
	70	110	25	19.0	25.00	1.5	1.5	0.6	24	98.1	147.0	22,054	33,047	3,300	4,500
		125	24	21.0	26.25	2.0	1.5	0.6	26	121.0	153.0	27,202	34,396	3,000	4,000
		125	31	27.0	33.25	2.0	1.5	0.6	29	155.0	203.0	34,845	45,636	2,800	3,800
		150	35	30.0	38.00	3.0	2.5	1.0	30	211.0	251.0	47,435	56,427	2,700	3,500
150		35	25.0	38.00	3.0	2.5	1.0	47	178.0	211.0	40,016	47,435	2,700	3,500	
150		51	42.0	54.00	3.0	2.5	1.0	36	293.0	398.0	65,869	89,474	2,700	3,500	
75	115	25	19.0	25.00	1.5	1.5	0.6	25	104.0	158.0	23,380	35,520	3,000	4,000	
	130	25	22.0	27.25	2.0	1.5	0.6	28	128.0	165.0	28,776	37,093	2,800	3,800	
	130	31	27.0	33.25	2.0	1.5	0.6	30	162.0	220.0	36,419	49,458	2,800	3,800	
	130	41	31.0	41.00	2.0	1.5	0.6	32	196.0	299.0	44,063	67,218	2,800	3,800	
	160	37	31.0	40.00	3.0	2.5	1.0	32	242.0	287.0	54,404	64,520	2,500	3,300	
	160	55	45.0	58.00	3.0	2.5	1.0	38	341.0	464.0	76,660	104,311	2,400	3,200	
	160	55	45.0	58.00	3.0	2.5	1.0	47	304.0	464.0	68,342	104,311	2,000	2,700	

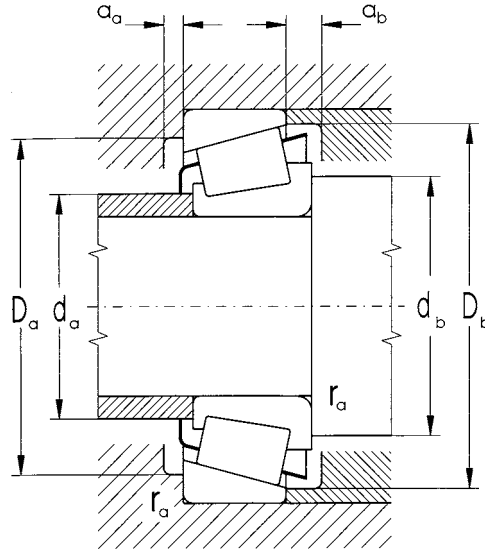

Bearing Designation		Abutment and Fillet Dimensions									Weight	Factors		
STN	ISO	d	d _a max	d _b min	D _a min	D _a max	D _b min	a _a min	a _b min	r _a max	~	e	Y	Y ₀
mm											kg			
32010AX	T3CC050	50	55	56	71	74	77	4	4.5	1.0	0.395	0.42	1.4	0.8
30210AJ2			58	57	78	83	86.5	3	4.5	1.0	0.602	0.42	1.4	0.8
32210A	T3DC050	58	57	78	83	85	3	5.5	1.0		0.667	0.42	1.4	0.8
30310A	T2FB050	62	60	94	100	102	3	6.0	2.0		1.320	0.35	1.7	1.0
31310A	T7FB050	61	60	85	100	104	3	10.0	1.0		1.290	0.83	0.7	0.4
32310A	T2FD050	62	60	94	100	102	3	9.0	2.0		2.010	0.35	1.7	1.0
32310BA	T5FD050	62	60	83	100	103	5	9.0	2.0		1.990	0.54	1.1	0.6
32011AX	T3CC055	55	61	62	80	83	86	4	5.5	1.0	0.592	0.41	1.5	0.8
30211A	T3DB055	63	64	87	91	94	4	4.5	1.5		0.759	0.41	1.5	0.8
32211A	T3DC055	63	64	87	91	95	4	5.5	1.5		0.915	0.41	1.5	0.8
30311A	T2FB055	67	65	103	110	111	4	6.5	2.0		1.710	0.35	1.7	1.0
31311A	T7FB055	67	65	92	110	113	4	10.5	2.0		1.630	0.83	0.7	0.4
32311A	T2FD055	67	65	103	110	111	4	10.5	2.0		2.500	0.35	1.7	1.0
32012AX	T4CC060	60	66	67	85	88	91	4	5.5	1.0	0.632	0.43	1.4	0.8
30212A	T3EB060		69	69	95	101	105.5	4	4.5	1.5	0.967	41.00	1.5	0.8
32212A	T3EC060	69	69	95	101	104	4	5.5	1.5		1.270	0.41	1.5	0.8
30312A	T2FB060	73	72	112	118	120	4	7.5	2.0		2.090	0.35	1.7	1.0
31312A	T7FB060	72	72	103	118	123	4	11.5	2.0		2.030	0.83	0.7	0.4
32312A	T2FD060	73	72	112	118	120	4	11.5	2.0		3.070	0.35	1.7	1.0
32312B	T5FD060	73	72	99	118	122	6	11.5	2.0		3.160	0.54	1.1	0.6
32013AX	T4CC065	65	71	72	90	93	97	4	5.5	1.0	0.675	0.46	1.3	0.7
33113A	T3DE065		74	72	96	103	106	6	7.5	1.0	1.300	0.39	1.5	0.8
30213A	T3EB065	75	74	105	111	113	4	4.5	1.5		1.230	0.41	1.5	0.8
32213A	T3EC065	75	74	105	111	115	4	5.5	1.5		1.660	0.41	1.5	0.8
33213A	T3EE065	75	74	102	111	115	6	9.0	1.5		2.060	0.39	1.5	0.9
30313A	T2GB065	80	77	121	128	130	4	8.0	2.0		2.550	0.35	1.7	1.0
31313A	T7GB065	78	77	109	128	132	4	13.0	2.0		2.450	0.83	0.7	0.4
32313A	T2GD065	80	77	121	128	130	4	12.0	2.0		3.770	0.35	1.7	1.0
32014AX	T4CC070	70	77	77	98	103	105	5	6.0	1.5	0.893	0.44	1.4	0.8
30214A	T3EB070		80	79	108	116	118	4	5.0	1.5	1.370	0.42	1.4	0.8
32214A	T3EC070	80	79	108	116	119	4	6.0	1.5		1.730	0.42	1.4	0.8
30314A	T2GB070	85	82	129	138	140	4	8.0	2.0		3.070	0.35	1.7	1.0
31314A	T7GB070	83	82	118	138	141	4	13.0	2.0		3.010	0.83	0.7	0.4
32314A	T2GD070	85	82	129	138	140	4	12.0	2.0		4.550	0.35	1.7	1.0
32015AX	T4CC075	75	82	82	103	108	110	5	6.0	1.0	0.955	0.46	1.3	0.7
30215A	T4DB075		85	84	113	121	124	4	5.0	1.5	1.470	0.44	1.4	0.8
32215A	T4DC075	85	84	113	121	121	4	6.0	1.5		1.820	0.44	1.4	0.8
33215A	T3EE075	85	84	111	121	125	6	10.0	1.5		2.300	0.43	1.4	0.8
30315A	T2GB075	91	87	138	148	149	4	9.0	2.0		3.720	0.35	1.7	1.0
32315A	T2GD075	91	87	138	148	149	4	13.0	2.0		5.620	0.35	1.7	1.0
32315B	T5GD075	90	87	128	148	150	7	12.5	2.0		5.600	0.54	1.1	0.6



Single Row Tapered Roller Bearings

d = 80 to 340 mm

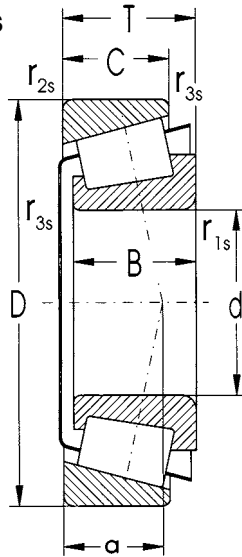

Dimension									Basic Load Rating				Limiting Speed for Lubrication with	
d	D	B	C	T	r _{1s} min	r _{2s} min	r _{3s} min	a	Dynamic C _r	Static C _{0r}	Dynamic C _r	Static C _{0r}	Grease	Oil
mm									kN	kN	lbs.	lbs.	rpm	
80	125	29	22.0	29.00	1.5	1.5	0.6	27	131.0	207.0	29,450	46,535	2,800	3,800
	130	37	29.0	37.00	2.0	1.5	0.6	31	190.0	300.0	42,714	67,443	3,200	4,200
	140	26	22.0	28.25	2.5	2.0	0.6	29	144.0	178.0	32,372	40,016	2,800	3,800
	140	33	28.0	35.25	2.5	2.0	0.6	32	181.0	251.0	40,690	56,427	2,800	3,800
85	130	29	22.0	29.00	1.5	1.5	0.6	28	136.0	215.0	30,574	48,334	2,800	3,800
	130	36	29.5	36.00	1.5	1.5	0.6	26	195.0	319.0	43,838	71,714	3,000	4,000
	150	28	24.0	30.50	2.5	2.0	0.6	30	181.0	207.0	40,690	46,535	2,700	3,500
	150	36	30.0	38.50	2.5	2.0	0.6	34	212.4	290.2	47,749	65,240	2,400	3,300
	150	36	30.0	38.50	2.5	2.0	0.6	34	237.0	293.0	53,280	65,869	2,700	3,500
	150	49	37.0	49.00	2.5	2.0	0.6	37	278.0	418.0	62,497	93,970	2,200	3,200
90	140	32	24.0	32.00	2.0	1.5	0.6	30	150.0	228.0	33,721	51,256	2,700	3,500
	140	39	32.5	39.00	2.0	1.5	0.6	28	223.0	370.0	50,132	83,179	2,800	3,800
	150	45	35.0	45.00	2.5	2.0	0.6	36	265.0	420.0	59,574	94,420	2,800	3,800
	160	30	26.0	32.50	2.5	2.0	0.6	31	185.0	242.0	41,590	54,404	2,400	3,200
	160	40	34.0	42.50	2.5	2.0	0.6	37	251.0	355.0	56,427	79,807	2,400	3,200
	190	43	30.0	46.50	4.0	3.0	1.0	59	301.0	366.0	67,667	82,280	1,700	2,400
95	145	32	24.0	32.00	2.0	1.5	0.6	31	178.0	290.0	40,016	65,195	2,700	3,500
	145	39	32.5	39.00	2.0	1.5	0.6	29	228.0	385.0	51,256	86,551	2,700	3,500
	170	32	27.0	34.50	3.0	2.5	1.0	33	237.0	308.0	53,280	69,241	2,700	3,500
	170	43	37.0	45.50	3.0	2.5	1.0	38	310.0	437.0	69,691	98,242	2,700	3,500
100	150	32	24.0	32.00	2.0	1.5	0.6	33	178.0	261.0	40,016	58,675	2,400	3,200
	150	39	32.5	39.00	2.0	1.5	0.6	29	234.0	400.0	52,605	89,924	2,500	3,300
	180	34	29.0	37.00	3.0	2.5	1.0	37	266.0	346.0	59,799	77,784	2,500	3,300
	180	46	39.0	49.00	3.0	2.5	1.0	41	348.0	496.0	78,234	111,505	2,500	3,300
105	160	35	26.0	35.00	2.5	2.0	0.6	35	211.0	348.0	47,435	78,234	2,600	3,400
	160	43	34.0	43.00	2.5	2.0	0.6	31	260.0	445.0	58,450	100,040	2,400	3,200
	190	36	30.0	39.00	3.0	2.5	1.0	37	293.0	387.0	65,869	87,001	2,400	3,200
	190	50	43.0	53.00	3.0	2.5	1.0	44	393.0	570.0	88,350	128,141	2,400	3,200
110	170	38	29.0	38.00	2.5	2.0	0.6	37	250.0	413.0	56,202	92,846	2,500	3,300
	170	47	37.0	47.00	2.5	2.0	0.6	33	300.0	520.0	67,443	116,901	2,200	3,000
	200	38	32.0	41.00	3.0	2.5	1.0	39	304.0	402.0	68,342	90,373	1,800	2,500
	200	53	46.0	56.00	3.0	2.5	1.0	46	433.0	630.0	97,342	141,630	2,200	3,000
120	180	38	29.0	38.00	2.5	2.0	0.6	40	254.0	430.0	57,101	96,668	2,400	3,200
	215	40	34.0	43.50	3.0	2.5	1.0	43	339.0	452.0	76,210	101,614	1,600	2,200
	215	58	50.0	61.50	3.0	2.5	1.0	52	484.0	727.0	108,808	163,436	1,900	3,000
130	200	45	34.0	45.00	2.5	2.0	0.6	43	338.0	578.0	75,985	129,940	2,100	2,800
140	210	45	34.0	45.00	2.5	2.0	0.6	46	335.0	580.0	75,311	130,389	1,700	2,200
170	310	52	43.0	57.00	5.0	4.0	1.5	61.4	690.0	995.0	155,118	223,685	1,020	1,450
180	250	45	34.0	45.00	2.5	2.0	0.6	54	351.0	761.0	78,908	171,080	1,160	1,660
190	260	45	34.0	45.00	2.5	2.0	0.6	55	371.0	799.0	83,404	179,622	1,110	1,580
220	300	51	39.0	51.00	3.0	2.5	1.0	59	498.0	1016.0	111,955	228,406	930	1,330
280	380	63.5	48.0	63.50	3.0	2.5	1.0	75	763.0	1624.0	171,529	365,090	700	1,000
340	460	76	57.0	76.00	4.0	3.0	1.0	90.5	1064.0	2332.0	239,197	524,254	550	780

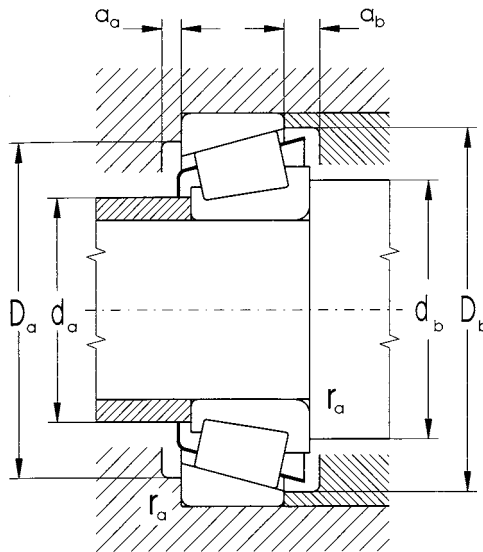

Bearing Designation		Abutment and Fillet Dimensions									Weight	Factors		
STN	ISO	d	d _a max	d _b min	D _a min	D _a max	D _b min	a _a min	a _b min	r _a max	~	e	Y	Y ₀
mm											kg			
32016AX	T3CC080	80	87	87	112	118	120	6	7.0	1.0	1.32	0.42	1.40	0.80
33116A	T3DE080		89	89	114	121	126	6	8.0	1.5	1.93	0.42	1.40	0.80
30216A	T3EB080		90	90	122	130	132	4	6.0	2.0	1.75	0.42	1.40	0.80
32216A	T3EC080		90	90	122	130	134	4	7.0	2.0	2.29	0.42	1.40	0.80
32017AX	T4CC085	85	92	92	117	123	125	6	7.0	1.0	1.41	0.44	1.40	0.70
33017A	T2CE085		92	93	117	123	125	6	6.5	1.0	1.73	0.29	2.10	1.10
30217A	T3EB085		96	95	132	140	141	5	6.0	2.0	2.14	0.42	1.40	0.80
32217A	T3EC085		96	95	130	140	142	5	8.5	2.0	2.85	0.42	1.40	0.80
32217AJ2	T3EC085		96	95	130	140	142	5	8.5	2.0	2.85	0.42	1.40	0.80
33217A	T3EE085		96	95	128	140	144	7	12.0	2.0	3.69	0.42	1.40	0.80
32018AX	T3CC090	90	99	99	124	131	134	6	8.0	1.5	1.78	0.42	1.40	0.80
33018A	T2CE090		99	99	124	131	135	6	6.5	1.5	2.25	0.27	2.20	1.20
33118A	T3DE090		101	100	130	140	144	7	10.0	2.0	3.20	0.40	1.50	0.80
30218A	T3FB090		102	100	138	150	150	5	6.0	2.0	2.71	0.42	1.40	0.80
32218A	T3FC090		102	100	138	150	152	5	8.5	2.0	3.60	0.42	1.40	0.80
31318A	T7GB090		109	104	151	176	179	6	16.5	3.0	5.42	0.83	0.73	0.40
32019AX	T4CC095	95	105	104	130	136	139	6	8.0	1.5	1.87	0.44	1.40	0.80
33019A	T2CE095		103	104	130	136	139	6	6.5	1.5	2.34	0.28	2.10	1.20
30219A	T3FB095		107	110	148	158	159	5	7.0	2.0	3.16	0.42	1.40	0.80
32219A	T3FC095		107	110	148	158	161	5	10.0	2.0	4.32	0.42	1.40	0.80
32020AX	T4CC100	100	109	109	134	141	144	6	8.0	1.5	1.94	0.46	1.30	0.70
33020A	T2CE100		109	110	134	141	144	6	6.5	1.5	2.47	0.28	2.10	1.10
30220A	T3FB100		114	112	155	168	168	5	8.0	2.0	3.81	0.42	1.40	0.80
32220A	T3FC100		114	112	155	168	171	5	10.0	2.0	5.21	0.42	1.40	0.80
32021AX	T4DC105	105	116	115	143	150	154	6	9.0	2.0	2.51	0.44	1.40	0.70
33021A	T2DE105		116	116	143	150	153	6	9.0	2.0	3.06	0.28	2.10	1.20
30221A	T3FB105		120	117	163	178	178	8	9.0	2.0	4.94	0.42	1.40	0.80
32221A	T3FC105		120	117	163	178	178	6	10.0	2.0	6.38	0.42	1.40	0.80
32022AX	T4DC110	110	120	120	152	160	163	6	9.0	2.0	3.09	0.43	1.40	0.80
33022A	T2DE110		121	121	150	159	160	6	10.0	2.0	3.87	0.29	2.10	1.20
30222A	T3FB110		125	122	171	188	187	8	9.0	2.0	5.32	0.44	1.40	0.80
32222A	T3FC110		125	122	171	188	190	6	10.0	2.0	7.56	0.44	1.40	0.80
32024AX	T4DC120	120	130	130	162	170	173	6	9.0	2.0	3.32	0.46	1.30	0.70
30224A	T4FB120		135	132	187	203	201	9	9.0	2.0	6.33	0.44	1.40	0.80
32224A	T4FD120		135	132	184	203	204	9	11.5	2.0	9.42	0.44	1.40	0.80
32026AX	T4EC130	130	140	140	178	190	192	8	11.0	2.0	5.05	0.44	1.40	0.80
32028AX	T4DC140	140	150	150	186	200	202	8	11.0	2.0	5.26	0.46	1.30	0.70
30234	T4GB170	170	202	188	272	292	288	8	14.0	4.0	17.40	0.44	1.38	0.76
32936	T4DC180	180	194	190	225	240	241	8	11.0	2.0	6.70	0.48	1.25	0.69
32938	T4DC190	190	204	200	235	250	251	8	11.0	2.0	7.00	0.48	1.26	0.69
32944	T3EC220	220	235	232	277	288	293	9	14.0	2.5	10.50	0.43	1.41	0.78
32956	T4EC280	280	299	292	349	368	371	8	15.0	2.5	20.30	0.43	1.39	0.76
32968	T4FD340	340	363	354	422	446	449	15	21.0	3.0	35.60	0.44	1.37	0.75

Single Row Tapered Roller Bearings in Inch Dimensions

d = 15.875 to 38.100 mm

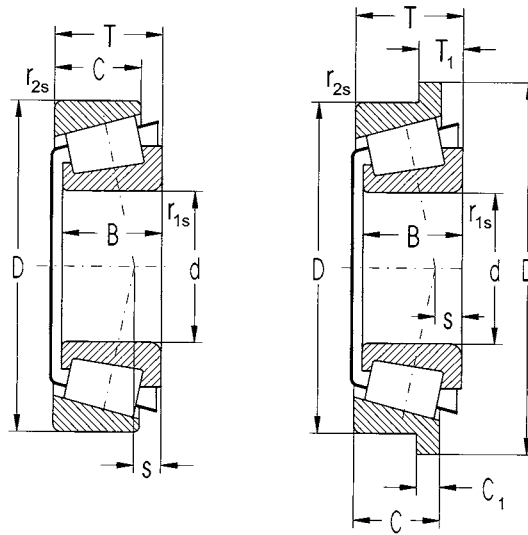

Dimension											Basic Load Rating			
d	D	D ₁	B	C	C ₁	T	T ₁	r _{1s} min	r _{2s} min	s	Dynamic C _r	Static C _{0r}	Dynamic C _r	Static C _{0r}
mm inch											kN	kN	lbs.	lbs.
15.875 0.6250	42.863 1.6875	-	14.288 0.5625	9.525 0.3750	-	14.288 0.5625	-	1.5 0.059	1.5 0.059	1.3 0.051	17.3	18.6	3,889	4,181
16.000 0.6299	47.000 1.8504	-	21.000 0.8268	16.000 0.6299	-	21.000 0.8268	-	1.00 0.039	2.00 0.079	6.00 0.236	36.9	40.6	8,295	9,127
17.462 0.6875	39.878 1.5700	-	14.605 0.5750	10.670 0.4201	-	13.843 0.5450	-	1.30 0.0512	1.30 0.0512	4.80 0.1890	21.1	21.5	4,743	4,833
19.050	45.237	-	16.637	12.065	-	15.494	-	1.30	1.30	5.60	25.6	26.6	5,755	5,980
0.7500	1.7810	-	0.6550	0.4750	-	0.6100	-	0.0512	0.0512	0.2205				
21.986 0.8656	45.237 1.7810	-	16.637 0.6550	12.065 0.4750	-	15.494 0.6100	-	1.20 0.0472	1.20 0.0472	5.30 0.2087	28.7	29.9	6,452	6,722
22.000 0.8661	45.000 1.7717	51.5 2.0276	16.637 0.6550	12.065 0.4750	3.000 0.1181	15.494 0.6100	6.429 0.2531	1.20 0.0472	1.20 0.0472	5.400 0.2126	28.7	29.9	6,452	6,722
25.400 1.0000	50.292 1.9800	-	14.732 0.5800	10.668 0.4200	-	14.224 0.5600	-	1.30 0.0512	1.30 0.0512	3.30 0.1299	24.6	28.7	5,530	6,452
	50.292 1.9800	-	14.732 0.5800	10.668 0.4200	-	14.224 0.5600	-	1.30 0.0512	1.30 0.0512	3.30 0.1299	24.6	28.7	5,530	6,452
	59.930 2.3594	-	23.114 0.9100	18.288 0.7200	-	23.368 0.9200	-	0.80 0.0315	1.57 0.0618	5.10 0.2008	44.7	66.8	10,049	15,017
26.988 1.0625	50.292 1.9800	-	14.732 0.5800	10.668 0.4200	-	14.224 0.5600	-	3.56 0.1402	1.30 0.0512	3.30 0.1299	24.6	28.7	5,530	6,452
29.000 1.1417	50.292 1.9800	-	14.732 0.5800	10.668 0.4200	-	14.224 0.5600	-	3.60 0.1417	1.20 0.0472	3.20 0.1260	25.6	33.5	5,755	7,531
30.000 1.1811	62.000 2.4409	68.5 2.6969	18.100 0.7126	15.536 0.6117	3.556 0.1400	17.250 0.6791	5.270 0.2075	1.00 0.0394	1.50 0.0591	3.30 0.1299	44.7	44.7	10,049	10,049
30.162 1.1875	64.292 2.5312	-	21.433 0.8438	16.670 0.6563	-	21.433 0.8438	-	1.57 0.0618	1.57 0.0618	3.30 0.1299	44.7	59.6	10,049	13,399
31.750 1.2500	59.131 2.3280	-	16.764 0.6600	11.811 0.4650	-	15.875 0.6250	-	4.75 0.1870	1.30 0.0512	2.90 0.1142	31.6	38.3	7,104	8,610
	62.000 2.4409	-	19.050 0.7500	14.288 0.5625	-	18.161 0.7150	-	4.75 0.1870	1.30 0.0512	5.20 0.2047	47.3	58.4	10,633	13,129
34.925 1.3750	65.088 2.5625	-	18.288 0.7200	13.970 0.5500	-	18.034 0.7100	-	4.75 0.1870	1.30 0.0512	3.70 0.1457	43.0	53.1	9,667	11,937
	73.025 2.8750	-	24.608 0.9688	19.050 0.7500	-	23.813 0.9375	-	3.56 0.1402	2.36 0.0929	6.60 0.2598	57.3	76.4	12,882	17,175
35.000 1.3780	60.000 2.3622	-	16.764 0.6600	11.938 0.4700	-	15.875 0.6250	-	4.75 0.1870	1.30 0.0512	2.50 0.0984	31.6	42.2	7,104	9,487
38.000 1.4961	63.000 2.4803	-	17.000 0.6693	13.500 0.5315	-	17.000 0.6693	-	1.50 0.0591	1.50 0.0591	2.30 0.0906	42.2	55.2	9,487	12,409
38.100 1.5000	65.088 2.5625	-	18.288 0.7200	13.970 0.5500	-	18.034 0.7100	-	2.30 0.0906	1.10 0.0433	5.00 0.1969	49.2	60.7	11,061	13,646

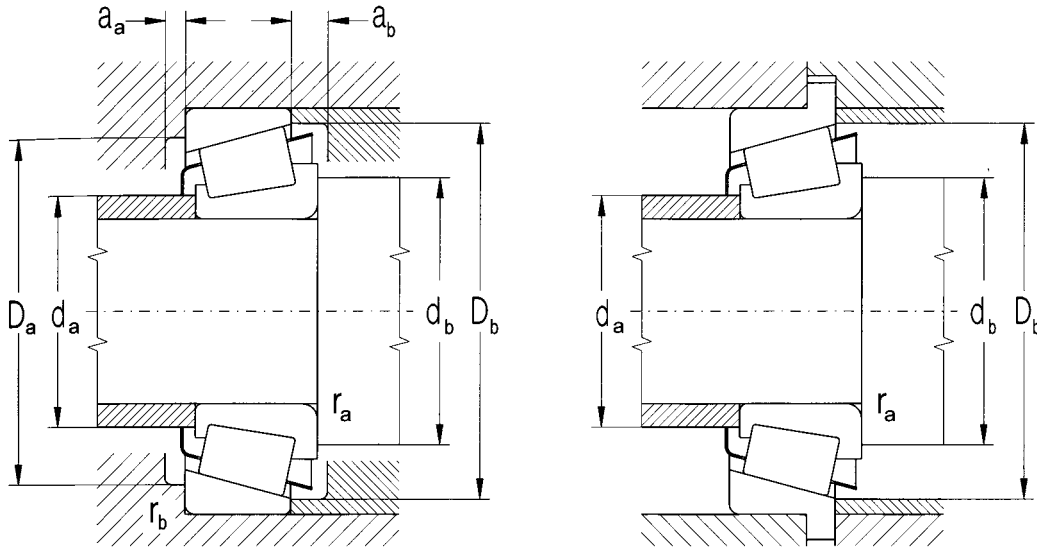

Limiting Speed for Lubrication with		Bearing Designation	Abutment and Fillet Dimensions									Weight	Factors		
Grease	Oil		STN	da max	db min	Da min	Da max	D _b min	da min	ab min	ra max		rb max	-	e
rpm			mm inch									kg			
9,500	14,000	K-11590/ K-11520	22.5 0.886	24.5 0.965	34.5 1.358	35 1.378	39.5 1.555	2 0.079	4.5 0.177	1.5 0.059	1.5 0.059	0.063	0.70	0.90	0.50
8,400	11,000	K-HM81649/ K-HM81610	23 0.906	22 0.866	36 1.417	39 1.535	43 1.693	2 0.079	4 0.157	1 0.039	1.5 0.059	0.199	0.55	1.10	0.60
10,000	13,000	K-LM11749/ K-HM11710	23 0.906	24 0.945	33.5 1.319	35 1.378	37 1.457	2 0.079	3 0.118	1 0.039	1 0.039	0.186	0.29	2.10	1.20
8,900	12,000	K-LM11949/ K-LM11910	25 0.984	25.5 1.004	38 1.496	38.5 1.516	41 1.614	3 0.118	3 0.118	1 0.039	1 0.039	0.121	0.30	2.00	1.10
8,400	11,000	K-LM1 2749/ K-LM12710	26 1.024	27.5 1.083	38 1.496	38.5 1.516	42.5 1.673	3 0.118	3 0.118	1.2 0.047	1.2 0.047	0.119	0.31	1.96	1.00
8,400	11,000	K-LM1 2749/ K-LM12712B	26 1.024	27.5 1.083	-	-	46 1.811	1.2 0.047	3.5 0.138	1.3 0.051	-	0.129	0.31	1.96	1.10
7,500	10,000	K-L44643/ K-L44610	33 1.299	32 1.260	43.5 1.713	43.5 1.713	47 1.850	2 0.079	3.5 0.138	1 0.039	1 0.039	0.128	0.37	1.60	0.90
7,500	10,000	K-L44643/ K-L44610/ K-L44600LA	33 1.299	32 1.260	43.5 1.713	43.5 1.713	-	2 0.079	-	1 0.039	1 0.039	0.130	0.37	1.60	0.90
5,600	7,500	K-M84249/ K-M84210	33 1.299	32 1.260	46 1.811	53 2.087	56 2.205	3 0.118	4.5 0.177	0.6 0.024	1 0.039	0.327	0.55	1.10	0.60
7,500	10,000	K-L44649/ K-L44610	33 1.299	38 1.496	43.5 1.713	45 1.772	47 1.850	3 0.118	3.5 0.138	3 0.118	1 0.039	0.120	0.37	1.60	0.90
7,100	9,400	K-L45449/ K-L45410	34 1.339	40 1.575	43.5 1.713	45 1.772	47 1.850	3 0.118	3.5 0.138	3 0.118	1 0.039	0.113	0.37	1.60	0.90
6,700	8,900	K-JXC25640CB/ K-JXC25640D	34.5 1.358	37 1.457	-	-	59 2.323	1.15 0.045	1.7 0.067	1.5 0.059	-	0.269	0.37	1.60	0.90
5,600	7,500	K-M86649/ K-M86610	38 1.496	38 1.496	51 2.008	56.5 2.224	60 2.362	3 0.118	4.5 0.177	1 0.039	1 0.039	0.341	0.55	1.10	0.60
6,700	8,900	K-LM67048/ K-LM67010	38 1.496	44.5 1.752	51 2.008	52 2.047	55 2.165	3 0.118	4 0.157	3 0.118	1 0.039	0.180	0.41	1.50	0.80
6,300	8,400	K-15123/ K-15245	38 1.496	43.5 1.713	54 2.126	55 2.165	58 2.283	4 0.157	3.5 0.138	3 0.118	1 0.039	0.248	0.35	1.70	0.90
5,600	7,500	K-LM48548/ K-LM48510	42 1.654	47 1.850	57 2.244	58 2.283	61 2.402	3 0.118	4 0.157	3 0.118	1 0.039	0.244	0.38	1.60	0.90
5,300	6,700	PLC65-3	43 1.693	45 1.772	62 2.441	64 2.520	68 2.677	3 0.118	3 0.118	5 0.197	2 0.079	0.495	0.37	1.60	0.90
6,300	8,400	K-L68149/ K-L68111	40 1.575	46 1.811	52 2.047	54 2.126	56 2.205	3 0.118	3.5 0.138	3 0.118	1 0.039	0.176	0.42	1.40	0.80
6,700	8,900	K-JL69349/ K-JL69310	41 1.614	49 1.929	56.5 2.244	57 2.244	60 2.362	1.5 0.059	3.5 0.138	1.5 0.059	1.5 0.059	0.204	0.42	1.44	0.79
5,600	7,500	K-LM29749/ K-LM29710	42.5 1.673	46 1.811	58 2.283	60 2.362	62 2.441	4 0.157	4 0.157	2.3 0.091	1.3 0.051	0.240	0.33	1.80	1.00

Single Row Tapered Roller Bearings in Inch Dimensions

d = 39.688 to 146.05 mm

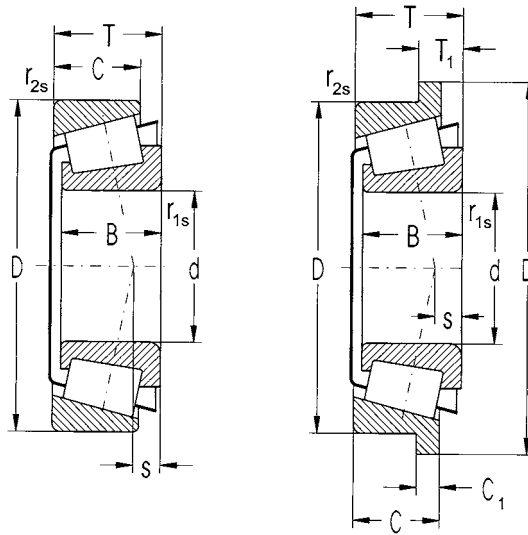

Dimension											Basic Load Rating			
d	D	D ₁	B	C	C ₁	T	T ₁	r _{1s} min	r _{2s} min	s	Dynamic C _r	Static C _{0r}	Dynamic C _r	Static C _{0r}
mm inch											kN	kN	lbs.	lbs.
39.688 1.5625	80.167 3.1562	-	30.391 1.1965	29.370 1.1563	-	29.370 1.1563	-	0.80 0.031	3.20 0.126	11.10 0.437	81.0	104.0	18,210	23,380
40.000 1.5748	80.000 3.1496	-	22.403 0.8820	17.826 0.7018	-	21.000 0.8268	-	0.80 0.031	1.30 0.051	6.00 0.236	70.8	73.6	15,916	16,546
40.100 1.5787	67.975 2.6762	-	18.000 0.7087	13.500 0.5315	-	17.500 0.6890	-	3.60 0.142	1.50 0.059	3.60 0.142	47.3	59.6	10,633	13,399
44.450 1.7500	83.058 3.2700	-	25.400 1.0000	19.050 0.7500	-	23.813 0.9375	-	3.56 0.140	3.2 0.126	6.10 0.240	59.6	87.4	13,399	19,648
45.242 1.7812	77.788 3.0625	-	19.842 0.7812	15.800 0.6220	-	19.842 0.7812	-	1.0 0.039	1.0 0.039	2.3 0.091	59.6	77.9	13,399	17,513
50.000 1.9685	82.000 3.2283	-	21.500 0.8465	17.000 0.6693	-	21.500 0.8465	-	3.0 0.118	0.5 0.020	5.3 0.209	75.2	104.0	16,906	23,380
50.800 2.0000	101.600 4.0000	-	36.068 1.4200	29.988 1.1806	-	34.925 1.3750	-	0.80 0.031	3.2 0.126	12.70 0.500	123.0	162.0	27,652	36,419
57.150 2.2500	127.000 5.0000	-	44.450 1.7500	34.925 1.3750	-	44.450 1.7500	-	3.5 0.138	3.3 0.130	9.4 0.370	228.0	276.0	51,256	62,047
65.000 2.5591	110.000 4.3307	-	28.000 1.1024	22.500 0.8858	-	28.000 1.1024	-	3.00 0.118	2.5 0.098	4.00 0.157	133.0	188.0	29,900	42,264
75.000 2.9528	115.000 4.5276	-	25.000 0.9843	19.000 0.7480	-	25.000 0.9483	-	5.00 0.197	2.5 0.098	0.0 -	104.0	158.0	23,380	35,519
88.900 3.5000	152.400 6.0000	-	39.688 1.5625	30.162 1.1875	-	39.688 1.5625	-	6.40 0.252	3.3 0.130	35.0 1.378	230.0	344.0	51,706	77,334
89.974 3.5423	146.975 5.7864	-	40.000 1.5748	32.500 1.2795	-	40.000 1.5748	-	7.00 0.276	3.5 0.138	31.0 1.220	243.0	365.0	54,629	82,055
90.000 3.5433	145.000 5.7087	-	34.000 1.3386	27.000 1.0630	-	35.000 1.3780	-	6.00 0.236	2.5 0.098	33.0 1.299	213.0	315.0	47,884	70,815
146.050 5.7500	193.675 7.6250	-	28.575 1.1250	23.020 0.9063	-	28.575 1.1250	-	5.8 0.228	1.5 0.059	34.0 1.339	181.0	390.0	40,690	87,675

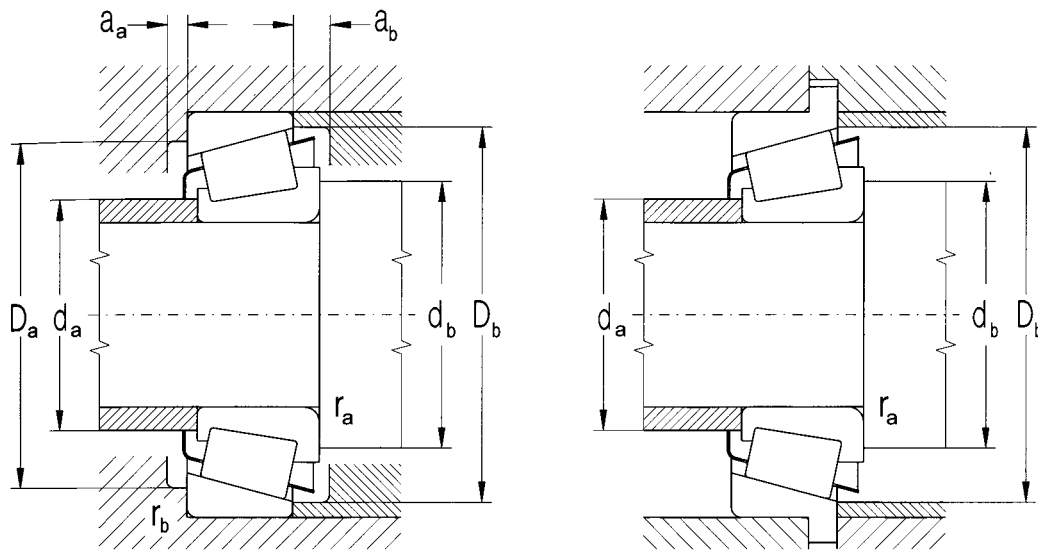

Limiting Speed for Lubrication with		Bearing Designation	Abutment and Fillet Dimensions										Weight	Factors		
Grease	Oil		STN	da max	db min	Da min	Da max	Db min	da min	ab min	ra max	rb max		-	e	γ
rpm			mm inch										kg			
4,200	5,600	K-3386/ K-3320	48 1.890	47 1.850	68 2.677	70 2.756	75 2.953	3 0.118	4 0.157	0.6 0.024	3 0.118	0.704	0.27	2.20	1.20	
4,700	6,300	K-344A/ K-322	48 1.890	47 1.850	68 2.677	73 2.874	75 2.953	3 0.118	4 0.157	0.6 0.024	1 0.039	0.514	0.27	2.20	1.20	
5,300	7,100	K-LM300849/ K-LM300811	45 1.772	52 2.047	58 2.283	61 2.402	63 2.480	4 0.157	4 0.157	0.6 0.024	1.5 0.059	0.230	0.35	1.70	1.00	
4,200	5,600	K-25580/ K-25521	53 2.087	56.5 2.224	71 2.795	74 2.913	73 2.874	5 0.197	4.5 0.177	3 0.118	3 0.118	0.541	0.33	1.80	1.00	
4,900	6,500	LM603049/ LM603011	50 1.969	57 2.244	71 2.795	72 2.835	74 2.913	4.5 0.177	5.5 0.217	1 0.039	1 0.039	0.378	0.43	1.41	0.77	
4,500	6,000	K-JLM104948/ K-JLM104910	55 2.165	60 2.362	76 2.992	77 3.031	78 3.071	4 0.157	4.5 0.177	3 0.118	0.5 0.020	0.410	0.31	1.097	1.08	
3,200	4,200	K-529/ K-522	61 2.402	63.5 2.500	87 3.425	89.5 3.524	94 3.701	6 0.236	7.5 0.295	0.6 0.024	3 0.118	1.220	0.28	2.10	1.20	
3,000	4,000	K-65225/ K-65500	71 2.795	80 3.150	104 4.094	107 4.213	119 4.685	10 0.394	10 0.394	3.5 0.138	3.3 0.130	2.790	0.49	1.20	0.70	
3,300	4,500	K-JM511946/ K-JM511910	71 2.795	77 3.031	93 3.661	96 3.780	101 3.976	9.5 0.374	9.5 0.374	3 0.118	2.5 0.098	1.050	0.39	1.50	0.90	
3,000	4,000	K-JLM714149/ K-JLM714110	82 3.228	82 3.228	103 4.055	108 4.252	110 4.331	5 0.197	6 0.236	1 0.039	-	0.955	0.46	1.30	0.70	
2,000	3,000	K-HM518445/ K-HM518410	98 3.858	112 4.409	124 4.882	135 5.315	142 5.591	6 0.236	10 0.394	3.5 0.138	-	2.880	0.44	1.36	0.74	
2,400	3,300	K-HM218248/ K-HM218210	99 3.898	112 4.409	128 5.039	133 5.236	141 5.551	6 0.236	7.5 0.295	3.5 0.138	-	2.590	0.33	1.80	0.99	
2,200	3,200	K-JM718149/ K-JM718110	99 3.898	111 4.370	126 4.961	131 5.157	140 5.512	6 0.236	8 0.315	2.5 0.098	-	2.150	0.44	1.35	0.74	
1,700	2,200	K-36691/ K-36620	155 6.102	162 6.378	176 6.929	182 7.165	187 7.362	6 0.236	6.5 0.256	1.5 0.059	-	2.310	0.37	1.6	0.9	



Four - Row Tapered Roller Bearings

d = 160 to 630 mm

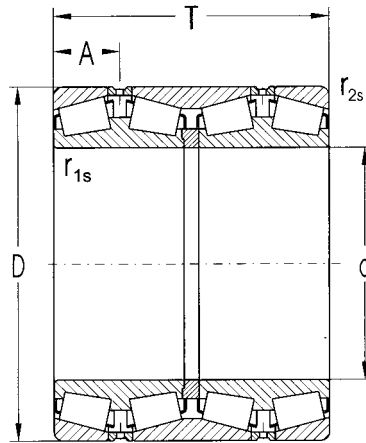

Dimension						Basic Load Rating			
d	D	T	r _{1s} min	r _{2s} min	A	Dynamic C _r	Static C _{0r}	Dynamic C _r	Static C _{0r}
mm						kN	kN	lbs.	lbs.
160	240	145	2.5	2.5	34.25	799	1,724	179,622	387,571
170	260	160	2.5	2.5	37.75	990	2,140	222,561	481,091
180	280	180	2.5	2.5	42.50	1,147	2,494	257,856	560,674
190	290	180	2.5	2.5	42.50	1,170	2,597	263,026	583,829
200	310	200	2.5	2.5	47.50	1,415	3,112	318,105	699,605
220	340	218	3.0	3.0	51.75	1,682	3,766	378,129	846,630
240	360	218	3.0	3.0	51.75	1,704	3,923	383,074	881,925
260	400	250	4.0	4.0	59.75	2,234	5,082	502,223	1,142,479
280	420	250	4.0	4.0	59.75	2,267	5,294	509,642	1,190,139
300	460	290	4.0	4.0	69.25	2,908	6,755	653,744	1,518,584
320	480	290	4.0	4.0	69.25	2,958	7,036	664,985	1,581,756
340	520	325	5.0	5.0	77.50	3,523	8,529	792,002	1,917,395
360	480	218	3.0	3.0	51.75	2,170	5,992	487,835	1,347,055
	540	325	5.0	5.0	77.50	3,583	8,868	805,490	1,993,606
380	560	325	5.0	5.0	77.50	3,645	9,202	819,429	2,068,692
400	600	355	5.0	5.0	84.75	4,338	10,633	975,221	2,390,393
420	620	355	5.0	5.0	84.75	4,422	11,052	994,105	2,484,588
500	720	400	6.0	6.0	95.00	5,387	14,325	1,211,046	3,220,388
525	780	450	6.0	6.0	106.50	6,663	17,558	1,497,902	3,947,195
530	780	450	6.0	6.0	106.50	6,663	17,558	1,497,902	3,947,195
630	920	515	7.5	7.5	125.00	8,730	24,230	1,962,582	5,447,121

Limiting Speed for Lubrication with		Bearing Designation	Weight	Factors			
Grease	Oil		~	e	Y ₁	Y ₂	Y ₀
rpm			kg				
710	940	36032	23.6	0.45	1.5	2.2	1.5
630	840	36034	30.0	0.46	1.5	2.2	1.5
590	780	36036	40.5	0.45	1.5	2.2	1.5
540	720	36038	42.5	0.47	1.4	2.2	1.4
500	670	36040	51.5	0.44	1.5	2.3	1.5
420	560	36044	71.6	0.45	1.5	2.3	1.5
400	530	36048	76.3	0.48	1.4	2.1	1.4
330	450	36052	111	0.44	1.5	2.3	1.5
320	420	36056	117	0.47	1.4	2.1	1.4
290	380	36060	169	0.44	1.5	2.3	1.5
260	340	36064	177	0.47	1.4	2.2	1.4
240	320	36068	241	0.44	1.5	2.3	1.5
240	320	36972	113	0.43	1.6	2.3	1.5
220	290	36072	253	0.46	1.5	2.2	1.4
200	260	36076	263	0.48	1.4	2.1	1.4
190	250	36080	339	0.44	1.5	2.3	1.5
180	240	36084	351	0.46	1.5	2.2	1.4
140	190	360/500	504	0.47	1.4	2.1	1.4
126	170	360/525	713	0.45	1.5	2.2	1.5
126	170	360/530	693	0.45	1.5	2.2	1.5
94	126	360/630	1090	0.44	1.5	2.3	1.5

L

Single Row Tapered Roller Bearings for Special Applications

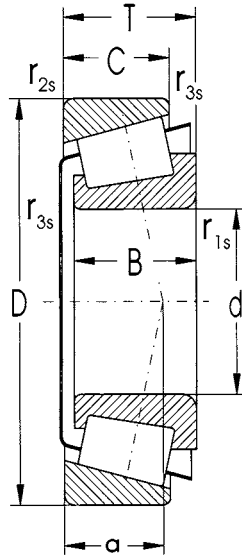

Dimension								Basic Load Rating			
d	D	B	C	T	r_{1s} min	r_{2sr} min	a	Dynamic C_r	Static C_{or}	Dynamic C_r	Static C_{or}
mm								kN	kN	lbs.	lbs.
21	62	17	13	18.25	1.5	1.5	20	36.2	39.1	8,138	8,790
26	57.15	17.462	14	17.462	3.2	1.3	12	35.5	42.2	7,981	9,487
30	62	16	14	17.25	4.3 ¹⁾	1.0	14	40.6	44.7	9,127	10,049
36	90	33	27	35.25	21.5	27.0	104	144.0	200.0	32,372	44,962
38	63	17	13.5	17	1.5	1.5	14.5	42.2	55.2	9,487	12,409
40	90	40.5	27	42.75	2.0	1.5	22	114.0	141.0	25,628	31,698
70	110	21.5	17.5	25.3	1.5	1.5	28	70.8	96.2	15,916	21,627

¹⁾ In axial and radial directions (r_{1smax} - 5.3 mm)

²⁾ By its main dimensions it corresponds to the bearing 32014AX, but the inner construction is different.

Limiting Speed for Lubrication with		Bearing Designation	Weight	Factors		
Grease	Oil			e	Y	Y ₀
rpm						
6,700	8,900	PLC 64-2-3	0.290	0.83	0.70	0.40
6,700	8,900	PLC 64-11	0.216	0.35	1.75	0.95
6,700	8,900	PLC 64-4-2	0.249	0.37	1.60	0.90
4,200	5,600	PLC 66-8-2	1.160	0.54	1.10	0.60
6,700	8,900	PLC 64-7	0.209	0.42	1.40	0.80
4,200	5,600	PLC 66-10-2	1.240	0.35	1.70	1.00
4,000	5,300	PLC 67-6 ²⁾	0.782	0.56	1.10	0.60

L

Thrust Ball Bearings



ZVL-ZKL thrust ball bearings are divided into two basic groups, single direction and double direction. Single direction thrust ball bearings have one row of balls within a cage, running between two grooved washers. The washers have flat seating surfaces that must be completely supported so that all of the balls can be evenly loaded. This bearing design is solely for carrying axial loads in one direction.

Double direction thrust ball bearings are used for reversing axial loads. There are two grooved housing washers, two ball and retainer assemblies, and an intermediate face. The housing washer and ball and retainer assemblies are the same as those of the corresponding single direction thrust ball bearing. Double direction thrust ball bearings can withstand axial loads in both directions.

Thrust ball bearings are used in applications where axial loads are too high to be supported by radial bearings or when rigid axial guidance is required.

Cage

All standard production thrust ball bearings are produced with a steel cage. Please check with ZVL-ZKL for availability of thrust ball bearings with brass or polyamide cages.

Boundary Dimensions

All boundary dimensions comply with standard ISO 15.

Tolerance

Thrust ball bearings are produced to ABEC 1 or P0 tolerance class. Bearings that require a higher tolerance class may be produced upon request.

Misalignment

Thrust ball bearings will not accept misalignment in any amount.

Axial Equivalent Dynamic Load

$$P_a = F_a$$

[kN]

M

Minimum Axial Load

At high rotational speeds a roller thrust bearing may experience roller element sliding if a minimum load is not applied. For calculation of minimum axial load $F_{a \min}$ the following equation can be used:

$$F_{a \min} = M \cdot \left(\frac{n_{\max}}{1000} \right)^2 \quad [\text{kN}]$$

$F_{a \min}$ - minimum axial load [kN]
 n_{\max} - maximum rotational speed [rpm]
 M - minimum axial load factor

If the axial load applied is too small, it is necessary to create an axial load with the use of springs or a similar device.

Axial Equivalent Static Load

$$P_{oa} = F_a \quad [\text{kN}]$$

Designation

Listed below are some common designations for thrust ball bearings.

Thrust Ball Bearings		
Suffix	Description	Example of Designation
A	Internal design change for enhanced limiting speed	51106 A
F	Machined steel cage guided on the rolling elements	51148 F
M	Machined brass cage guided on the rolling elements	51144 M
TNGN	Polyamide cage reinforced with glass fiber, guided on the rolling elements	51408A TNGN
P6	Higher tolerance class than normal	51307 P6
P5	Higher tolerance class than P6	51216 P5

Single Direction Thrust Ball Bearings

d = 10 to 70 mm

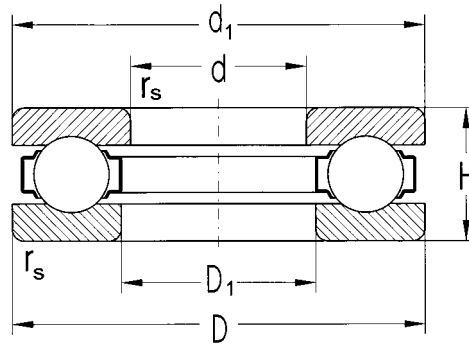

Dimension						Basic Load Rating			
d	D	d ₁	D ₁	H	r _s min	Dynamic C _a	Static C _{0a}	Dynamic C _a	Static C _{0a}
mm						kN	kN	lbs.	lbs.
10	24	24	11	9	0.3	10.0	9.09	2,248	2,045
12	26	26	13	9	0.3	10.4	10.40	2,338	2,338
15	28	28	16	9	0.3	10.6	11.90	2,382	2,675
	32	13	17	12	0.6	15.8	16.50	3,551	3,709
17	30	30	18	9	0.3	11.4	14.40	2,562	3,237
	35	35	19	12	0.6	16.2	18.80	3,641	4,226
20	35	35	21	10	0.3	15.0	19.60	3,372	4,406
	40	40	22	14	0.6	22.4	26.10	5,035	5,867
25	42	42	26	11	0.6	18.1	27.10	4,069	6,092
	47	47	27	15	0.6	27.6	36.20	6,204	8,138
	52	52	27	18	1.0	35.5	42.20	7,980	9,486
	60	60	27	24	1.0	55.2	55.20	12,409	12,409
30	47	47	32	11	0.6	18.8	31.60	4,226	7,103
	52	52	32	16	0.6	29.3	43.80	6,586	9,846
	60	60	32	21	1.0	43.0	55.20	9,666	12,409
	70	70	32	28	1.0	72.2	81.00	16,231	18,209
35	52	52	37	12	0.6	20.0	38.30	4,496	8,610
	62	62	37	18	1.0	39.1	58.40	8,790	13,128
	68	68	37	24	1.0	55.2	73.60	12,409	16,545
	80	80	37	32	1.1	87.4	100.00	19,648	22,480
40	60	60	42	13	0.6	27.1	51.10	6,092	11,487
	68	68	42	19	1.0	43.8	70.80	9,846	15,916
	78	78	42	26	1.0	69.4	94.40	15,601	21,221
	90	90	42	36	1.1	122.00	133.00	27,426	29,899
45	65	65	47	14	0.6	27.6	57.30	6,204	12,881
	73	73	47	20	1.0	46.4	81.00	10,431	18,209
	85	85	47	28	1.0	79.4	117.00	17,849	26,302
	100	100	47	39	1.1	131.0	158.00	29,449	35,519
50	70	70	52	14	0.6	28.7	63.10	6,452	14,185
	78	78	52	22	1.0	47.3	87.40	10,633	19,648
55	78	78	57	16	0.6	34.8	77.90	7,823	17,512
	90	90	57	25	1.0	69.4	123.00	15,601	27,651
	105	105	57	35	1.1	119.0	174.00	26,752	39,116
	120	120	57	48	1.5	207.0	251.00	46,535	56,427
60	85	85	62	17	1.0	41.4	94.40	9,307	21,221
	110	110	62	35	1.1	123.0	192.00	27,651	43,163
65	100	100	67	27	1.0	75.0	150.00	16,860	33,721
	115	115	67	36	1.1	128.0	211.00	28,775	47,434
70	95	95	72	18	1.0	43.0	110.00	9,666	24,728
	105	105	72	27	1.0	76.4	162.00	17,175	36,419
	125	125	72	40	1.1	147.0	251.00	33,046	56,427
	150	150	73	60	2.0	251.0	369.00	56,427	82,954

M

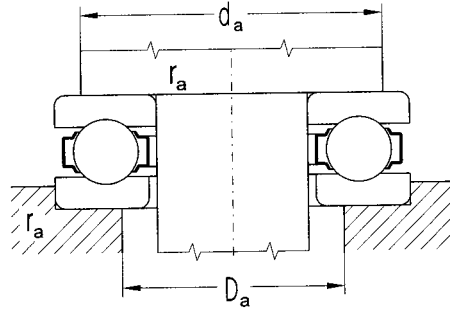

Limiting Speed for Lubrication with		Bearing Designation	Abutment and Fillet Dimensions				Weight	Minimum Axial Load Factor
Grease	Oil		d	d_a min	D_a max	r_a max		
rpm			mm				kg	
7,900	10,600	51100A	10	19	15	0.3	0.02	0.001
7,500	10,000	51101A	12	21	17	0.3	0.02	0.002
7,100	9,400	51102A	15	23	20	0.3	0.02	0.002
6,000	7,900	51202A		25	22	0.6	0.05	0.004
7,100	9,400	51103A	17	25	22	0.3	0.03	0.003
5,600	7,500	51203A		28	24	0.6	0.05	0.004
6,300	8,400	51104A	20	29	26	0.3	0.04	0.004
5,000	6,700	51204A		32	28	0.6	0.08	0.008
5,300	7,100	51105A	25	35	32	0.6	0.06	0.006
4,500	6,000	51205A		38	34	0.6	0.12	0.015
3,800	5,000	51305A		41	36	1.0	0.18	0.020
3,200	4,200	51405A		46	39	1.0	0.34	0.035
5,000	6,700	51106A	30	40	37	0.6	0.07	0.008
4,000	5,300	51206A		43	39	0.6	0.14	0.018
3,300	4,500	51306A		48	42	1.0	0.27	0.030
2,700	3,500	51406A		54	46	1.0	0.53	0.085
4,700	6,300	51107A	35	45	42	0.6	0.08	0.012
3,500	4,700	51207A		51	46	1.0	0.22	0.032
2,800	3,800	51307A		55	48	1.0	0.39	0.050
2,200	3,000	51407A		62	53	1.0	0.79	0.120
4,200	5,600	51108A	40	52	48	0.6	0.12	0.018
3,200	4,200	51208A		57	51	1.0	0.27	0.047
2,700	3,500	51308A		63	55	1.0	0.55	0.095
2,000	2,700	51408ATNGN		70	60	1.0	1.14	0.190
4,000	5,300	51109A	45	57	53	0.6	0.15	0.025
3,000	4,000	51209A		62	56	1.0	0.32	0.060
2,400	3,200	51309A		69	61	1.0	0.69	0.130
1,900	2,500	51409A		78	67	1.0	1.47	0.350
3,800	5,000	51110A	50	62	58	0.6	0.16	0.035
2,800	3,800	51210A		67	61	1.0	0.39	0.082
3,300	4,500	51111A	55	69	64	0.6	0.24	0.040
2,500	3,300	51211A		76	69	1.0	0.61	0.110
1,900	2,500	51311A		85	75	1.0	1.34	0.270
1,600	2,100	51411A		94	81	1.5	2.64	0.650
3,200	4,200	51112A	60	75	70	1.0	0.29	0.066
1,900	2,500	51312A		90	80	1.0	1.43	0.350
2,400	3,200	51213A	65	86	79	1.0	0.77	0.170
1,800	2,400	51313A		95	85	1.0	1.57	0.450
2,800	3,800	51114A	70	85	80	1.0	0.36	0.110
2,200	3,000	51214A		91	84	1.0	0.81	0.210
1,700	2,200	51314A		103	92	1.0	2.06	0.540
1,200	1,600	51414A		118	102	2.0	5.48	1.600

M

Single Direction Thrust Ball Bearings

d = 75 to 150 mm

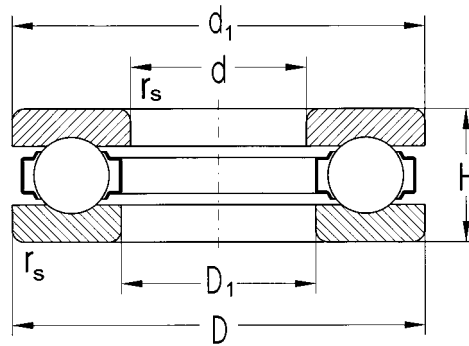

Dimension						Basic Load Rating			
d	D	d_1	D_1	H	r_s min	Dynamic C_a	Static C_{oa}	Dynamic C_a	Static C_{oa}
mm						kN	kN	lbs.	lbs.
75	100	100	77	19	1.0	43.8	119.0	9,846	26,752
	110	110	77	27	1.0	77.9	171.0	17,512	38,442
	135	135	77	44	1.5	185.0	310.0	41,589	69,690
80	105	105	82	19	1.0	44.7	123.0	10,048	27,651
	115	115	82	28	1.0	79.4	181.0	17,849	40,690
	170	170	83	68	2.1	316.0	482.0	71,039	108,357
85	110	110	87	19	1.0	45.5	133.0	10,228	29,899
	125	125	88	31	1.0	96.2	215.0	21,626	48,333
	150	150	88	49	1.5	224.0	376.0	50,357	84,528
90	120	120	92	22	1.0	59.9	165.0	13,398	37,093
	155	155	93	50	1.5	233.0	406.0	52,380	91,272
	190	187	93	77	2.1	383.0	619.0	86,101	139,156
100	135	135	102	25	1.0	85.8	228.0	19,288	51,256
	170	170	103	55	1.5	251.0	464.0	56,427	104,311
	210	205	103	85	3.0	447.0	779.0	100,489	175,126
110	145	145	112	25	1.0	87.4	251.0	19,648	56,427
	190	187	113	63	2.0	304.0	584.0	68,341	131,288
	230	225	113	95	3.0	492.0	909.0	110,606	204,351
120	155	155	122	25	1.0	89.1	271.0	20,030	60,923
	210	205	123	70	2.1	348.0	708.0	78,233	159,164
	250	245	123	102	4.0	531.0	1,040.0	119,373	233,801
130	170	170	132	30	1.0	119.0	355.0	26,752	79,807
	225	220	134	75	2.1	369.0	779.0	82,954	175,126
	270	265	134	110	4.0	631.0	1,280.0	141,854	287,755
140	240	235	144	80	2.1	414.0	962.0	93,070	216,266
	150	190	188	152	31	1.0	123.0	398.0	27,651

M

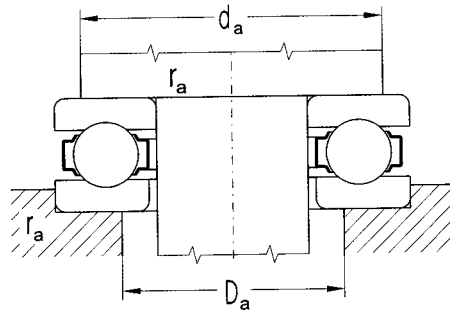

Limiting Speed for Lubrication with		Bearing Designation	Abutment and Fillet Dimensions				Weight	Minimum Axial Load Factor
Grease	Oil		d	d_a min	D_a max	r_a max		
rpm			mm				kg	
2700	3500	51115A	75	90	85	1.0	0.42	0.12
2200	3000	51215A		96	89	1.0	0.86	0.27
1600	2100	51315A		111	99	1.5	2.68	0.76
2700	3500	51116A	80	95	90	1.0	0.43	0.15
2000	2700	51216A		101	94	1.0	0.95	0.35
890	1200	51416		133	117	2.0	7.97	2.70
2700	3500	51117A	85	100	95	1.0	0.46	0.18
1900	2700	51217A		109	101	1.0	1.29	0.43
1300	1800	51317A		123	111	1.5	3.66	1.20
2200	3000	51118A	90	108	102	1.0	0.68	0.26
1100	1500	51318		129	116	1.5	3.88	1.50
790	1060	51418		149	131	2.0	11.20	4.10
2000	2700	51120A	100	121	114	1.0	0.99	0.34
1060	1400	51320		142	128	1.5	5.11	2.00
750	1000	51420		165	145	2.5	15.00	6.20
1900	2500	51122A	110	131	124	1.0	1.08	0.42
890	1200	51322		158	142	2.0	7.87	2.80
670	890	51422		181	159	2.5	20.20	9.00
1600	2100	51124	120	141	134	1.0	1.16	0.53
790	1060	51324		173	157	2.0	10.90	4.10
630	840	51424		197	173	3.0	25.50	13.00
1400	1900	51126	130	154	146	1.0	1.87	0.65
750	1000	51326		186	169	2.0	13.30	6.20
560	750	51426		213	187	3.0	32.00	18.00
710	940	51328	140	199	181	2.0	15.90	8.00
1300	1800	51130	150	174	166	1.0	2.20	0.95

M

Single Direction Thrust Ball Bearings

d = 160 to 1000 mm

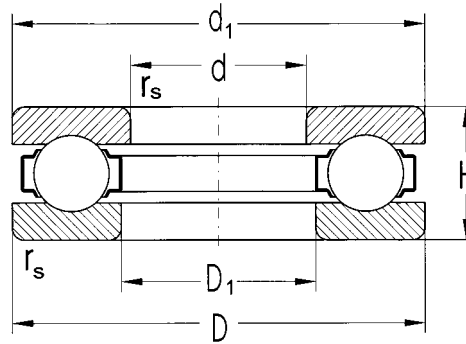

Dimension						Basic Load Rating			
d	D	d_1	D_1	H	r_s min	Dynamic C_a	Static C_{oa}	Dynamic C_a	Static C_{oa}
mm						kN	kN	lbs.	lbs.
160	200	198	162	31	1.0	126	422	28.325	94.869
	225	222	163	51	1.5	276	722	62.047	162.312
170	215	213	172	34	1.1	158	511	35.519	114.877
	240	237	173	55	1.5	282	750	63.396	168.606
180	225	222	185	34	1.1	165	562	37.093	126.342
	250	247	183	56	1.5	304	858	68.341	192.886
190	240	237	193	37	1.1	188	656	42.264	147.474
	270	267	194	62	2.0	355	1,020	79.807	229.305
200	250	247	203	37	1.1	185	631	41.689	141.854
	280	277	204	62	2.0	355	1,020	79.807	229.305
220	270	267	223	37	1.1	192	722	43.163	162.312
240	300	297	243	45	1.5	261	926	58.675	208.173
300	420	415	304	95	3.0	588	2,255	132.412	506.944
320	440	435	325	95	3.0	614	2,495	138.032	560.898
340	420	416	344	64	2.0	419	1,780	94.194	400.159
360	440	436	364	65	2.0	430	1,885	96.667	423.764
	500	495	365	110	5.0	727	3,264	163.436	733.776
400	480	476	404	65	3.0	446	2,141	100.264	481.315
420	500	495	424	65	2.0	460	2,255	103.412	506.944
1000	1180	1175	1005	140	5.0	1,377	11,595	309.561	2,606.659

M

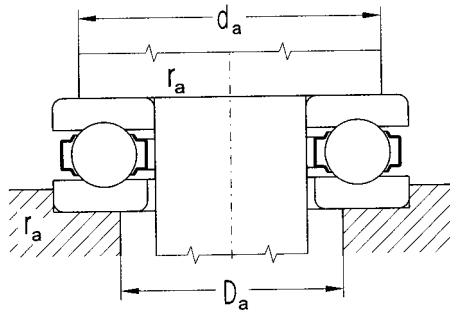

Limiting Speed for Lubrication with		Bearing Designation	Abutment and Fillet Dimensions				Weight	Minimum Axial Load Factor
Grease	Oil		d	d_a min	D_a max	r_a max		
rpm			mm				kg	
1.300	1.800	51132	160	184	176	1.0	2.33	1.20
890	1.200	51232		199	186	1.5	6.67	3.20
1.200	1.600	51134	170	197	188	1.0	3.31	1.50
840	1.100	51234		212	198	1.5	8.28	4.60
1.100	1.500	51136	180	207	198	1.0	3.48	1.90
840	1.100	51236		222	208	1.5	8.85	5.50
1.060	1.400	51138	190	220	210	1.0	4.06	2.40
750	1.000	51238		238	222	2.0	11.90	7.50
1.060	1.400	51140	200	230	220	1.0	4.24	3.10
750	1.000	51240		248	232	2.0	12.40	9.50
1.000	1.300	51144	220	250	240	1.0	4.62	4.60
840	1.100	51148	240	276	264	1.5	7.55	6.50
500	670	51260	300	372	348	2.5	43.10	40.00
470	630	51264	320	392	368	2.5	45.50	48.00
600	790	51168	340	388	372	2.0	20.30	19.00
560	750	51172	360	408	392	2.0	21.80	22.00
400	530	51272		443	417	3.0	70.60	90.00
530	710	51180	400	448	432	2.0	23.60	28.00
530	710	51184	420	470	450	2.0	25.00	30.00
210	280	511/1000	1000	1110	1070	4.0	270.00	720.00

M

Single Direction Thrust Ball Bearings for Special Applications

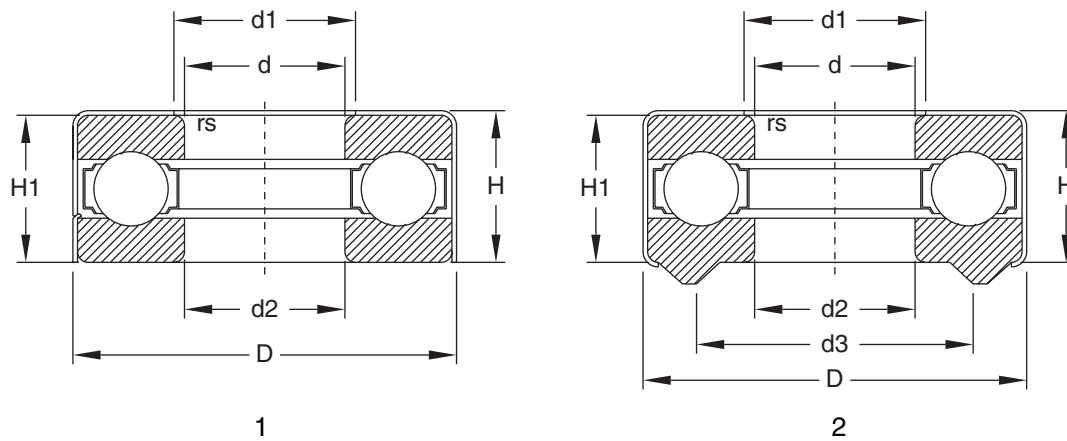

Dimension								Basic Load Rating			
d	D	H	d_1	d_2	d_3	H_1	r_s	Dynamic C_a	Static C_{0a}	Dynamic C_a	Static C_{0a}
mm								kN	kN	lbs.	lbs.
30	49.25	12.00	36	30.8	-	11.0	0.6	17.4	28.2	3,912	6,340
	49.25	13.55	36	30.8	40	12.5	0.6	17.4	28.2	3,912	6,340
35	53.60	15.50	38	37.0	40	14.7	0.6	20.0	38.3	4,496	8,610

M

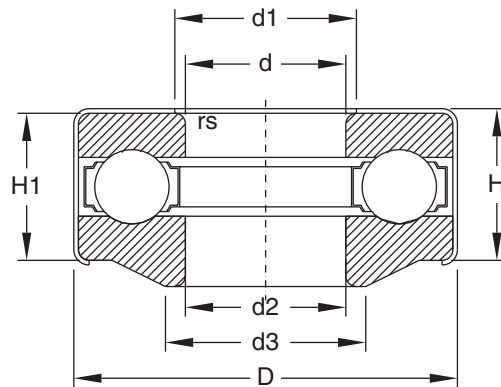

3

Limiting Speed for Lubrication with		Bearing Designation	Weight	Figure
Grease	Oil			
rpm			kg	
4,200	-	PLC 23-4	0.083	1
4,200	-	PLC 23-5	0.085	2
3,500	-	PLC 24-2	0.111	3

M

Double Direction Thrust Ball Bearings

d = 10 to 140 mm

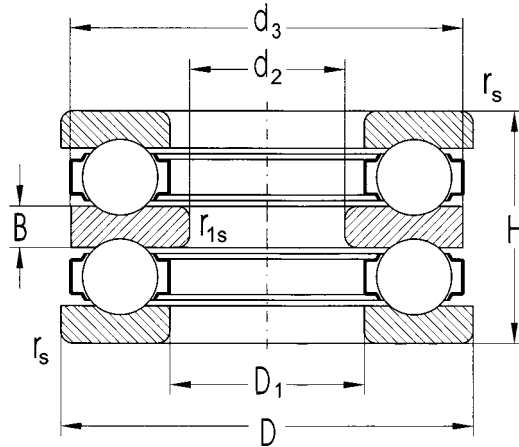

Dimension								Basic Load Rating				Limiting Speed for Lubrication with	
d ₂	D	d ₃	D ₁	H	B	r _s	r _{1s}	Dynamic C _a	Static C _{0a}	Dynamic C _a	Static C _{0a}	Grease	Oil
mm								kN	kN	lbs.	lbs.	rpm	
10	32	32.0	17	22	5	0.6	0.3	15.8	16.5	3,551	3,709	6,000	7,900
15	40	40.0	22	26	6	0.6	0.3	22.4	26.1	5,035	5,867	5,000	6,700
	60	60.0	27	45	11	1.0	0.6	55.2	55.2	12,406	12,409	3,200	4,200
20	47	47.0	27	28	7	0.6	0.3	27.6	36.2	6,204	8,135	4,500	6,000
	52	52.0	27	34	8	1.0	0.3	35.5	42.2	7,980	9,486	3,800	5,000
	70	70.0	32	52	12	1.0	0.6	72.2	81.0	16,231	18,209	2,700	3,500
25	52	52.0	32	29	7	0.6	0.3	29.3	43.8	6,586	9,846	4,000	5,300
	60	60.0	32	38	9	1.0	0.3	43.0	55.2	9,666	12,409	3,300	4,500
	80	80.0	37	59	14	1.1	0.6	87.4	100.0	19,648	22,480	2,200	3,000
30	62	62.0	37	34	8	1.0	0.3	39.1	58.4	8,790	13,128	3,500	4,700
	68	68.0	37	44	10	1.0	0.3	55.2	73.6	12,409	16,545	2,800	3,800
	68	68.0	42	36	9	1.0	0.6	43.8	70.8	9,846	15,916	3,200	4,200
	78	78.0	42	49	12	1.0	0.6	69.4	94.4	15,601	21,221	2,700	3,500
	90	90.0	42	65	15	1.1	0.6	112.0	133.0	25,178	29,899	2,000	2,700
35	73	73.0	47	37	9	1.0	0.6	46.4	81.0	10,431	18,209	3,000	4,000
	85	85.0	47	52	12	1.0	0.6	79.4	117.0	17,849	26,302	2,400	3,200
	100	100.0	47	72	17	1.1	0.6	131.0	158.0	29,449	35,519	1,900	2,500
40	78	78.0	52	39	9	1.0	0.6	47.3	87.4	10,633	19,648	2,800	3,800
45	90	90.0	57	45	10	1.0	0.6	69.4	123.0	15,601	27,651	2,500	3,300
	105	105.0	57	64	15	1.1	0.6	91.5	174.0	20,570	39,116	1,900	2,500
	120	120.0	57	87	20	1.5	0.6	156.0	251.0	35,070	56,427	1,600	2,100
50	110	110.0	62	64	15	1.1	0.6	95.0	192.0	21,356	43,163	1,900	2,500
55	100	100.0	67	47	10	1.0	0.6	75.0	150.0	16,860	33,721	2,400	3,200
	115	115.0	67	65	15	1.1	0.6	128.0	211.0	28,775	47,434	1,800	2,400
	105	105.0	72	47	10	1.0	1.0	76.4	162.0	17,175	36,419	2,200	3,000
	125	125.0	72	72	16	1.1	1.0	147.0	251.0	33,046	56,427	1,700	2,200
	150	150.0	73	107	24	2.0	1.0	251.0	369.0	56,427	82,964	1,200	1,600
60	110	110.0	77	47	10	1.0	1.0	77.9	171.0	17,512	38,442	2,200	3,000
	135	135.0	77	79	18	1.5	1.0	185.0	310.0	41,589	69,690	1,600	2,100
65	115	115.0	82	48	10	1.0	1.0	79.4	181.0	17,849	40,690	2,000	2,700
	170	170.0	83	120	27	2.1	1.0	316.0	482.0	71,039	108,357	890	1,200
70	125	125.0	88	55	12	1.0	1.0	96.2	215.0	21,626	48,333	1,900	2,500
	150	150.0	88	87	19	1.5	1.0	224.0	376.0	50,357	84,528	1,300	1,800
	190	189.5	93	135	30	2.1	1.1	383.0	619.0	86,101	139,156	790	1,060
75	155	155.0	93	88	19	1.5	1.0	233.0	406.0	52,380	91,272	1,100	1,500
100	210	209.5	123	123	27	2.1	1.1	348.0	708.0	78,233	159,164	790	1,060
140	225	224.5	163	90	20	1.5	1.1	276.0	722.0	62,047	162,312	890	1,200

M

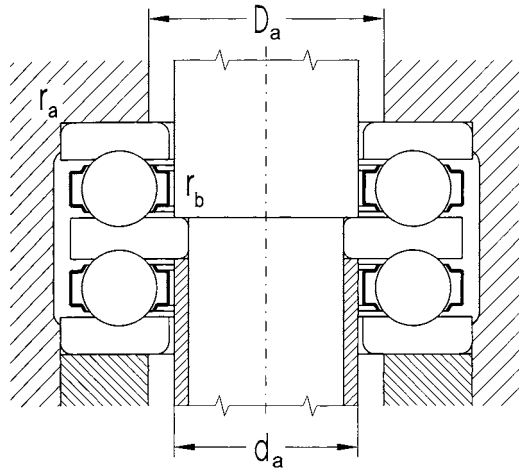

Bearing Designation	Abutment and Fillet Dimensions					Weight	Minimum Axial Load Factor
	d ₂	d _a min	D _a max	r _a max	r _b max		
	mm					kg	
52202A	10	15	22	0.6	0.3	0.08	0.004
52204A	15	20	28	0.6	0.3	0.15	0.008
52405A		25	39	1.0	0.6	0.63	0.035
52205A	20	25	34	0.6	0.3	0.23	0.015
52305A		25	36	1.0	0.3	0.33	0.020
52406A		30	46	1.0	0.6	1.00	0.085
52206A	25	30	39	0.6	0.3	0.27	0.018
52306A		30	42	1.0	3.0	0.49	0.030
52407A		35	53	1.0	0.6	1.44	0.120
52207A	30	35	46	1.0	0.3	0.42	0.032
52307A		35	48	1.0	0.3	0.71	0.050
52208A		40	51	1.0	0.6	0.54	0.047
52308A		40	55	1.0	0.6	1.06	0.095
52408ATNG		40	60	1.0	0.6	2.03	0.190
52209A	35	45	56	1.0	0.6	0.62	0.060
52309A		45	61	1.0	0.6	1.29	0.130
52409A		45	67	1.0	0.6	2.71	0.350
52210A	40	50	61	1.0	0.6	0.71	0.082
52211A	45	55	69	1.0	0.6	1.12	0.110
52311A		55	75	1.0	0.6	2.51	0.270
52411A		55	81	1.5	0.6	4.70	0.650
52312A	50	60	80	1.0	0.6	2.68	0.350
52213A	55	65	79	1.0	0.6	1.36	0.170
52313A		65	85	1.0	0.6	2.90	0.450
52214A		70	84	1.0	0.6	1.48	0.210
52314A		70	92	1.0	1.0	3.90	0.540
52414A		70	102	2.0	1.0	9.71	1.600
52215A	60	75	89	1.0	1.0	1.57	0.270
52315A		75	99	1.5	1.0	4.83	0.760
52216A	65	80	95	1.0	1.0	1.69	0.350
52416		80	117	2.0	1.0	14.50	2.700
52217A	70	85	101	1.0	1.0	2.34	0.430
52317A		85	111	1.5	1.0	6.43	1.200
52418		90	131	2.0	1.0	19.60	4.100
52318	75	90	116	1.5	1.0	6.60	1.500
52324	100	120	157	2.0	1.0	17.20	4.100
52232	140	160	186	1.5	1.0	12.60	3.200

M

Spherical Roller Thrust Bearing



ZVL-ZKL spherical roller thrust bearings contain a large number of asymmetrical barrel-shaped rollers, inclined so steeply that the bearing accommodates high axial loads in addition to considerable radial loads at relatively high rotational speeds. The spherical-shaped raceway of the housing washer accommodates misalignment between the shaft and housing. Spherical roller thrust bearings are separable, which allows the shaft washer, cage and roller assembly to be mounted separately from the housing washer. Due to their internal design these bearings need to be lubricated with oil, except under extremely low speeds where grease lubrication is adequate. Applications for this bearing type include column bearings for cranes, heavy worm gears, and screw pumps.

Selected sizes of ZVL-ZKL spherical roller thrust bearings are available in the "E" design; additional sizes are gradually being introduced into standard production. This design change uses larger rollers and makes better utilization of the internal space, which results in an increase of the basic dynamic load rating and the static load rating when compared to bearings of the original design.

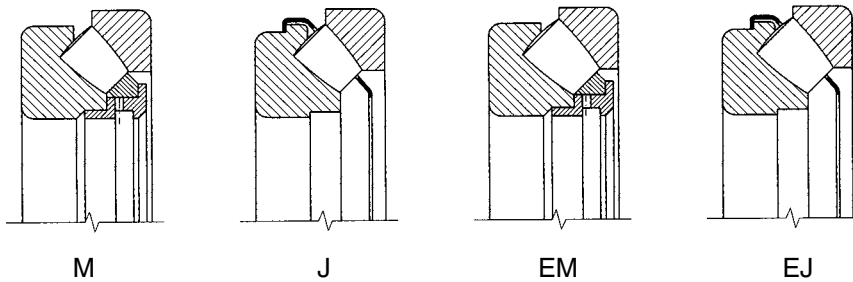

Cage

Spherical roller thrust bearings are designed and produced with steel and brass cages. Each cage design is designated by "J" for steel and "M" for brass cages. See the picture above for cage design construction. Some applications using the "EJ" design may require the use of shaft spacer.

Boundary Dimensions

Boundary dimensions of spherical roller thrust bearings comply with standard ISO 104.

Tolerance

Spherical roller thrust bearings are produced in accordance to ABEC 1 or P0 tolerance class. All of these tolerances comply with standard ISO 492.

Misalignment

The spherical raceway of the bearing housing washer enables the bearing to accept a considerable amount of misalignment. See the table below for approximate values of misalignment. Please note these values are sufficient for normal operating conditions.

Bearing Type	Permissible Misalignment
292	2°
293	2°30'
294	3°

Arrangement Design

The abutment and fillet dimensions shown in the dimension tables are suitable for bearings where the load $P_a < 0.1C_a$. At higher loads it is suitable to support the bearing's washer along the face surface; i.e., $d_a = d_1$ and $D_a = D_1$.

Axial Equivalent Dynamic Load

$$P_a = F_a + 1.2F_r \quad (F_r \leq 0.55F_a) \quad [\text{kN}]$$

Minimum Axial Load

At high rotational speeds a roller thrust bearing may experience roller element sliding if a minimum load is not applied. For calculation of minimum axial load $F_{a \min}$ the following equation can be used:

$$\frac{C_{oa}}{2000} \leq F_{a \min} = 1.8 \cdot F_r \cdot M \cdot \left(\frac{n_{\max}}{1000} \right)^2 \quad [\text{kN}]$$

$F_{a \min}$	- minimum axial load	[kN]
F_r	- radial bearing load	[kN]
C_{oa}	- axial basic static load rating	[kN]
n_{\max}	- maximum rotational speed	[rpm]
M	- minimum axial load factor	

If the axial load applied is too small, it is necessary to create an axial load with the use of springs or a similar device. If a radial load is applied simultaneously, the following condition must also be fulfilled:

$$F_r \leq 0.55F_a$$

Axial Equivalent Static Load

$$P_{oa} = F_a + 2.7F_r \quad (F_r \leq 0.55F_a) \quad [\text{kN}]$$

The static safety factor for spherical roller thrust bearings must be $s_0 \geq 4$.

Designation

Listed below are some common designations for spherical roller thrust bearings.

Spherical Roller Thrust Bearings		
Suffix	Description	Example of Designation
E	Internal design change for enhanced load carrying capacity	29416 EJ
J	Pressed steel cage guided on the rolling elements	29340 J
M	Machined brass cage guided on the rolling elements	29412 M

Spherical Roller Thrust Bearings

d = 60 to 180 mm

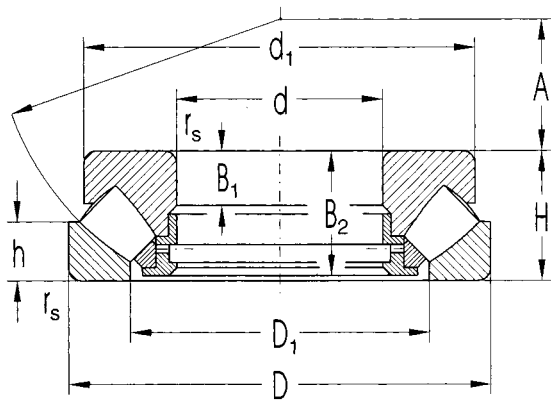

M, EM

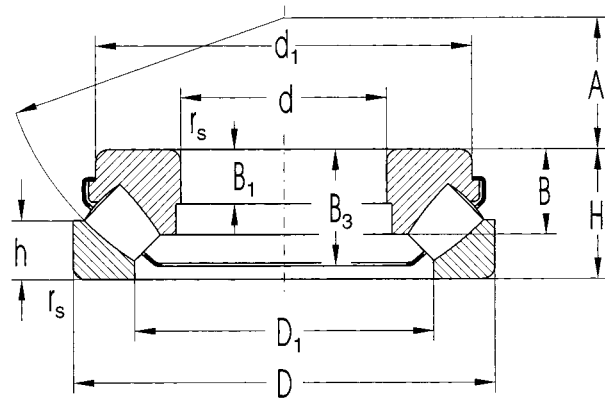

J, EJ

Dimension												Basic Load Rating			
d	D	H	d ₁	D ₁	B	B ₁	B ₂	B ₃	h	A	r _s min	Dynamic C _a	Static C _{0a}	Dynamic C _a	Static C _{0a}
mm												kN	kN	lbs.	lbs.
60	130	42	118	88.0	28.0	15.0	39.5	35.5	20	38	1.5	287	809	64,520	181,870
65	140	45	128	96.5	30.0	16.0	42.5	38.0	21	42	2.0	340	973	76,435	218,739
70	150	48	137	102.0	32.0	17.0	45.5	42.0	23	44	2.0	371	1,071	83,404	240,770
75	160	51	146	109.0	34.5	18.0	48.0	44.5	24	47	2.0	429	1,254	96,443	281,910
80	170	54	155	116.0	36.0	19.0	51.0	46.5	24	50	2.1	464	1,367	104,311	307,313
80	170	54	155	116.0	36.0	19.0	-	46.5	24	50	2.1	570	1,430	128,141	321,476
85	180	58	164	125.0	38.0	21.0	55.0	49.0	28	54	2.1	527	1,570	118,474	352,950
90	190	60	174	130.0	-	22.0	57.0	-	29	56	2.1	578	1,784	129,939	401,059
100	210	67	193	144.5	-	24.0	64.0	-	32	62	3.0	705	2,172	158,490	488,285
110	190	48	176	143.0	31.0	16.0	45.5	42.0	23	64	2.0	442	1,415	99,365	318,104
110	190	48	176	143.0	31.0	16.0	-	42.0	23	64	2.0	570	1,760	128,141	395,663
110	230	73	212	160.0	-	26.0	69.0	-	35	69	3.0	817	2,601	183,668	584,728
120	210	54	194	157.5	-	18.0	51.0	-	26	70	2.1	560	1,831	125,893	411,625
120	250	78	229	172.0	-	29.0	74.0	-	37	74	4.0	934	2,996	209,971	673,527
130	225	58	205	170.0	37.0	19.0	55.0	50.5	28	76	2.1	628	2,071	141,180	465,579
130	270	85	247	188.0	55.5	31.0	81.0	72.0	41	81	4.0	1,086	3,538	244,142	795,374
140	240	60	219	183.0	-	20.0	57.0	-	29	82	2.1	675	2,311	151,746	519,533
140	280	85	257	197.5	-	31.0	81.0	-	41	86	4.0	1,130	3,750	254,034	843,258
150	250	60	229	193.0	-	20.0	57.0	-	29	87	2.1	697	2,425	156,691	545,161
150	300	90	276	211.5	-	32.0	86.0	-	44	92	4.0	1,276	4,270	286,856	959,934
160	270	67	248	207.0	-	23.0	64.0	-	32	92	3.0	807	2,812	181,420	632,162
160	320	95	306	226.0	-	34.0	91.0	-	45	99	5.0	1,461	4,806	328,445	1,080,431
170	280	67	258	215.0	-	23.0	64.0	-	32	96	3.0	833	2,948	187,265	662,736
170	340	103	324	240.0	-	37.0	99.0	-	50	104	5.0	1,624	5,376	365,089	1,208,572
180	300	73	277	231.0	-	25.0	69.0	-	35	103	3.0	984	3,525	221,212	792,451
180	360	109	342	255.0	-	39.0	105.0	-	52	110	5.0	1,803	6,011	405,330	1,351,327

N

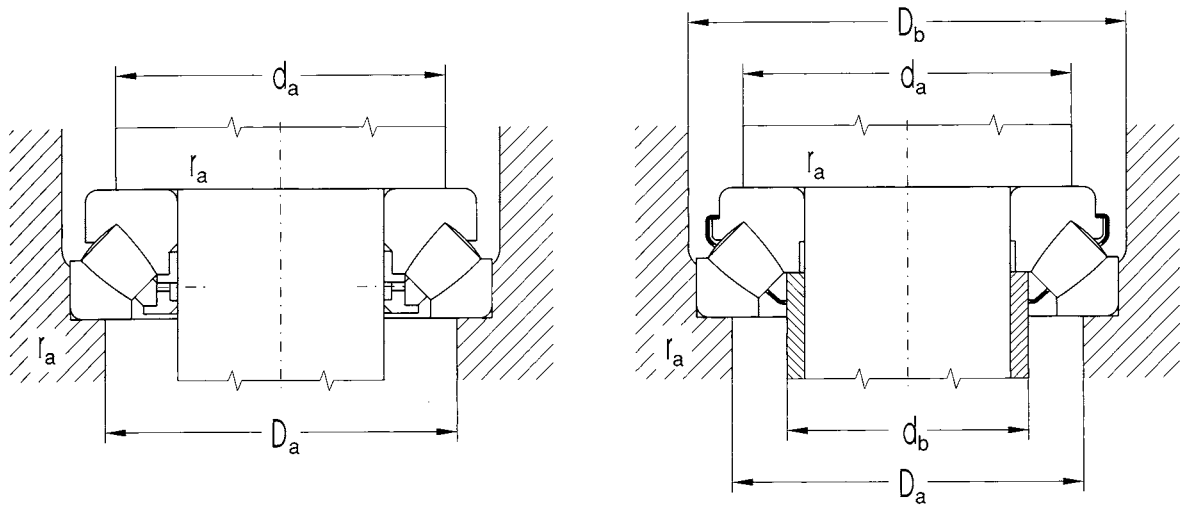

Limiting Speed for Lubrication with Oil	Bearing Designation		Abutment and Fillet Dimensions						Weight		Minimum Axial Load Factor
			d	d _a min	d _b max	D _a max	D _b min	r _a max	M	J	
rpm			mm						kg		
2400	29412M	29412J	60	90	67	109	140	1.5	2.60	2.47	0.08
2200	29413M	29413J	65	100	74	118	150	2.0	3.30	3.22	0.10
2000	29414M	29414J	70	105	79	126	160	2.0	4.00	3.98	0.14
2000	29415M	29415J	75	115	84	134	170	2.0	4.90	4.74	0.18
1900	29416M		80	120	88	141	180	2.0	5.80	5.57	0.25
2000		29416EJ		120	88	141	180	2.0	-	5.80	0.26
1800	29417M	29417J	85	130	97	153	190	2.0	6.90	6.64	0.30
1700	29418M		90	135	-	161	-	2.0	8.10	-	0.37
1500	29420M		100	150	-	178	-	2.5	11.80	-	0.60
1600	29322M		110	145	117	165	200	2.0	5.50	5.40	0.25
1800		29322EJ		145	117	165	200	2.0	-	5.40	0.25
1400	29422M			165	-	196	-	2.5	14.50	-	0.80
1400	29324M		120	160	-	184	-	2.0	7.60	-	0.36
1300	29424M			180	-	212	-	3.0	18.10	-	1.10
1300	29326M	29326J	130	170	140	198	235	2.0	9.30	8.65	0.52
1200	29426M			195	148	229	280	3.0	22.50	21.80	1.60
1300	29328M		140	185	-	211	-	2.0	11.00	-	0.68
1200	29428M			205	-	239	-	3.0	24.20	-	2.00
1200	29330M		150	195	-	222	-	2.0	11.50	-	0.90
1100	29430M	29430J		220	-	257	-	3.0	29.40	-	2.50
1100	29332M		160	210	-	239	-	2.5	15.20	-	1.10
1000	29432M			230	-	274	-	4.0	35.50	-	3.00
1100	29334M		170	220	-	248	-	2.5	16.00	-	1.40
940	29434M			245	-	291	-	4.0	43.70	-	3.80
1000	29336M		180	235	-	266	-	2.5	20.30	-	1.60
890	29436M			260	-	307	-	4.0	52.00	-	4.70

N

Spherical Roller Thrust Bearings

d = 190 to 380 mm

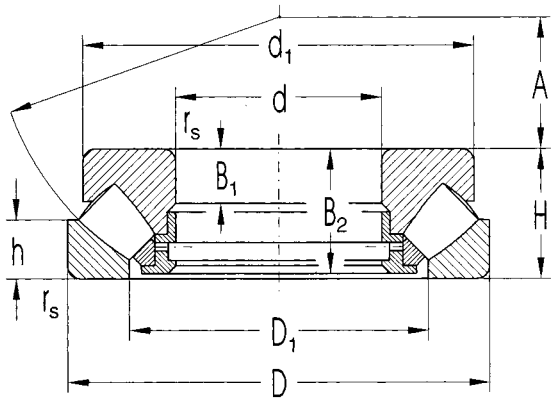

M, EM

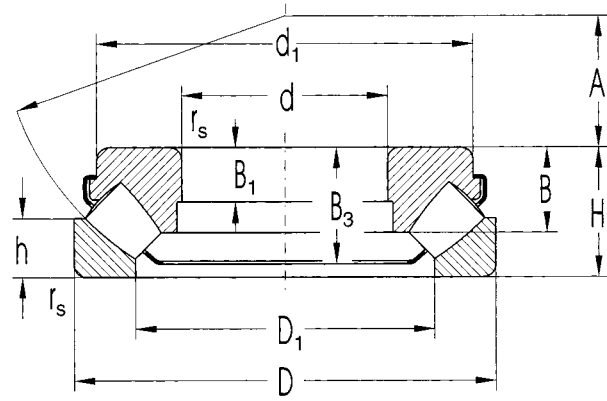

J, EJ

Dimension												Basic Load Rating			
d	D	H	d ₁	D ₁	B	B ₁	B ₂	B ₃	h	A	r _s min	Dynamic C ₂ kN	Static C _{02a} kN	Dynamic C _a lbs.	Static C _{02a} lbs.
mm															
190	320	78	308.0	246.0	-	27.0	74.0	-	38	110	4.0	1,115	4,013	250,661	902,158
320	78	284.4	239.5	49.0	28.0	-	68.0	-	36	110	4.0	1,440	4,840	323,725	1,088,075
380	115	360.0	270.0	-	41.0	111.0	-	-	55	117	5.0	1,960	6,607	440,625	1,485,312
200	340	85	325.0	261.0	-	29.0	81.0	-	41	116	4.0	1,299	4,740	292,028	1,065,594
340	85	302.8	253.6	53.5	29.0	-	73.0	40	116	4.0	1,620	5,480	364,190	1,231,953	
340	85	325.0	261.0	54.5	29.0	-	77.4	41	116	4.0	1,340	4,969	301,245	1,117,081	
400	122	380.0	284.0	-	43.0	117.0	-	-	59	122	5.0	2,208	7,508	496,378	1,687,865
220	360	85	345.0	280.0	-	29.0	81.0	-	41	125	4.0	1,340	4,969	301,243	1,117,075
360	85	324.4	273.0	55.0	29.0	-	74.0	41	125	4.0	1,740	6,300	391,168	1,416,296	
420	122	400.0	305.0	-	43.0	117.0	-	-	58	132	6.0	2,257	7,968	507,395	1,791,277
240	340	60	330.0	283.0	-	19.0	57.0	-	30	130	2.1	770	3,454	173,102	776,490
380	85	365.0	300.0	-	29.0	81.0	-	-	41	135	4.0	1,341	5,185	301,468	1,165,634
380	85	343.7	294.8	54.0	29.0	-	75.0	40.5	41	135	4.0	1,790	6,490	402,408	1,459,010
440	122	420.0	321.0	-	43.0	117.0	-	-	59	142	6.0	2,340	8,416	526,052	1,891,992
260	360	60	350.0	302.0	-	19.0	57.0	-	30	139	2.1	801	3,654	180,071	821,451
420	95	405.0	325.0	-	32.0	91.0	-	-	45	148	5.0	1,777	6,820	399,485	1,533,196
420	95	380.3	320.4	61.0	32.0	-	84.0	46	148	5.0	2,240	8,310	503,572	1,868,162	
480	132	460.0	346.0	-	48.0	127.0	-	-	64	154	6.0	2,730	9,871	613,728	2,219,089
280	380	60	370.0	323.0	-	19.0	57.0	-	30	150	2.1	847	3,952	190,413	888,444
440	95	423.0	345.0	-	32.0	91.0	-	-	46	158	5.0	1,778	7,103	399,710	1,596,817
440	95	401.7	342.1	62.0	32.0	-	84.0	45	158	5.0	2,310	8,490	519,309	1,908,628	
520	145	495.0	380.0	-	52.0	140.0	-	-	68	166	6.0	3,227	11,844	725,458	2,662,637
520	145	468.9	370.0	95.0	52.0	-	125.0	70	166	6.0	4,470	15,750	1,004,896	3,540,741	
300	420	73	405.0	355.0	-	21.0	69.0	-	38	162	3.0	1,025	4,665	230,429	1,048,733
480	109	460.0	375.0	-	37.0	105.0	-	-	50	168	5.0	2,182	8,504	490,533	1,911,775
480	109	431.9	366.7	70.0	36.0	-	95.0	51	168	5.0	2,650	11,000	595,744	2,472,898	
540	145	515.0	398.0	-	52.0	140.0	-	-	70	175	6.0	3,217	11,854	723,210	2,664,885
540	145	489.2	370.0	95.0	55.0	-	125.0	70	175	6.0	4,510	16,460	1,013,888	3,700,355	
320	440	73	430.0	375.0	-	21.0	69.0	-	38	172	3.0	1,065	4,925	239,421	1,107,184
500	109	482.0	395.0	-	37.0	105.0	-	-	53	180	5.0	2,183	8,854	490,757	1,990,458
500	109	456.1	387.0	68.0	37.0	-	95.0	53	180	5.0	2,850	10,920	640,705	2,454,914	
580	155	555.0	430.0	-	55.0	149.0	-	-	75	191	7.5	3,889	14,694	874,281	3,303,342
580	155	525.6	422.0	102.0	55.0	-	134.0	74.5	191	7.5	5,010	21,200	1,126,293	4,765,950	
340	540	122	520.0	424.0	-	41.0	117.0	-	59	192	5.0	2,644	10,554	594,294	2,372,633
620	170	590.0	452.0	-	61.0	164.0	-	-	82	201	7.5	4,346	16,413	977,019	3,689,789
360	500	85	485.0	420.0	-	25.0	81.0	-	44	194	4.0	1,402	6,596	315,182	1,482,839
560	122	540.0	444.0	-	41.0	117.0	-	-	59	202	5.0	2,654	11,031	596,642	2,479,867
380	520	85	505.0	440.0	-	27.0	81.0	-	42	202	4.0	1,545	7,511	347,329	1,688,539
670	175	640.0	510.0	-	63.0	168.0	-	-	85	222	7.5	4,600	18,300	1,034,121	4,114,003
670	175	622.0	504.0	-	63.0	168.0	-	-	85	222	7.5	4,700	19,100	1,056,602	4,293,850

N

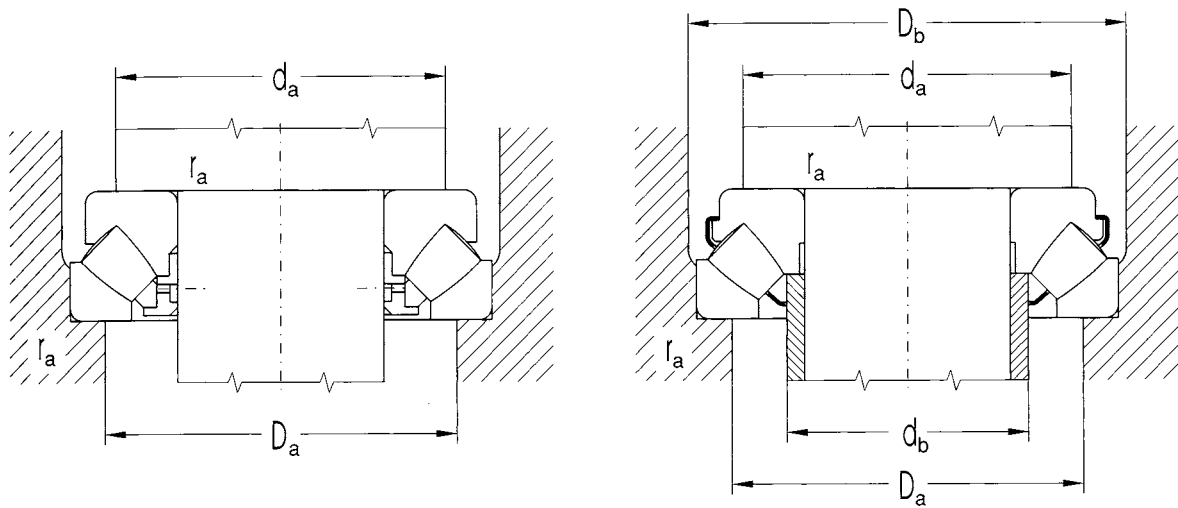

Limiting Speed for Lubrication with Oil rpm	Bearing Designation	Abutment and Fillet Dimensions						Weight		Minimum Axial Load Factor
		d	d _a min	d _b max	D _a max	D _b min	r _a max	M	J	
		mm						kg		
940	29338M	190	250	-	-	283	3.0	24.8	-	2.0
1100	29338EJ		250	-	-	383	3.0	-	23.3	2.0
840	29438M		275	-	-	325	4.0	60.0	-	5.7
890	29340M	200	265	-	-	300	3.0	30.8	-	2.4
950	29340EJ		265	-	-	300	3.0	-	29.0	2.4
890	29340J		265	224	350	300	3.0	-	28.9	2.4
790	29440M	290	-	-	343	4.0	69.0	-	6.8	
840	29344M	220	285	-	-	320	3.0	32.8	-	3.1
950	29344EJ		285	-	-	320	3.0	-	31.6	3.1
750	29444M		310	-	-	364	5.0	74.0	-	8.0
890	29248M	240	285	-	-	311	2.0	16.7	-	1.3
790	29348M		300	-	-	340	3.0	35.3	-	4.4
900	29348EJ		300	-	-	340	3.0	-	33.4	4.4
750	29448M	330	-	-	383	5.0	79.0	-	10.0	
890	29252M	260	305	-	-	331	2.0	18.5	-	1.5
750	29352M		330	-	-	374	3.0	48.5	-	5.7
800	29352EJ		330	-	-	374	3.0	-	46.9	5.7
670	29452M	360	-	-	419	5.0	105.0	-	13.0	
840	29256M	280	325	-	-	351	2.0	19.5	-	1.7
710	29356M		350	-	-	394	4.0	52.5	-	7.0
800	29356EJ		350	-	-	394	4.0	-	49.5	7.0
630	29456M	390	-	-	453	5.0	132.0	-	18.0	
630	29456EJ	390	-	-	453	5.0	-	127.0	18.0	
750	29260M	300	355	-	-	386	2.5	30.5	-	2.6
630	29360M		380	-	-	429	4.0	74.0	-	8.5
700	29360EJ		380	-	-	429	4.0	-	68.7	8.5
600	29460M	410	-	-	471	5.0	140.0	-	20.0	
600	29460EJ	410	-	-	471	5.0	-	133.0	20.0	
710	29264M	320	375	-	-	406	2.5	32.9	-	2.8
630	29364M		400	-	-	449	4.0	77.0	-	10.0
670	29364EJ		400	-	-	449	4.0	-	72.1	10.0
560	29464M	435	-	-	507	6.0	175.0	-	28.0	
560	29464EJ	435	-	-	507	6.0	-	164.0	28.0	
560	29368M	340	430	-	-	484	4.0	103.0	-	14.0
500	29468M		465	-	-	451	6.0	218.0	-	34.0
630	29272M	360	420	-	-	461	3.0	51.8	-	4.9
560	29372M		450	-	-	504	4.0	107.0	-	15.0
600	29276M	380	440	-	-	480	3.0	52.8	-	6.2
470	29476M		510	-	-	587	6.0	254.0	-	44.0
470	29476EM		504	-	-	570	6.0	254.0	-	44.0

N

Spherical Roller Thrust Bearings

d = 400 to 800 mm

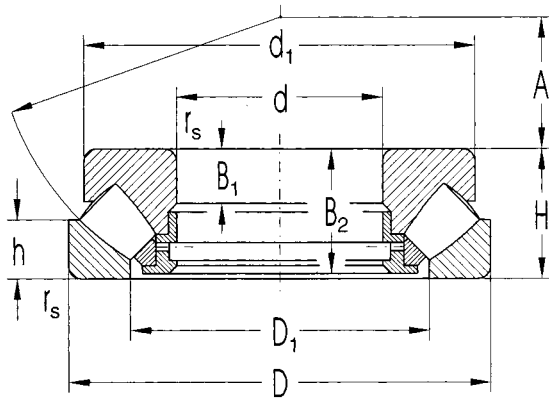

M, EM

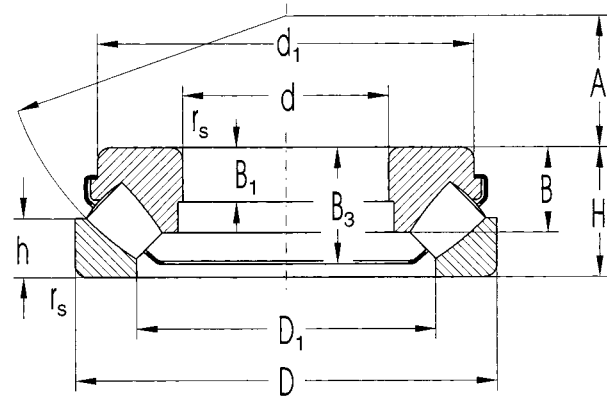

J, EJ

Dimension										Basic Load Rating			
d	D	H	d ₁	D ₁	B ₁	B ₂	h	A	r _s min	Dynamic C _a	Static C _{0a}	Dynamic C _a	Static C _{0a}
mm										kN	kN	lbs.	lbs.
400	540	85	526	460.0	27.0	81.0	42	212	4.0	1,602	7,899	360,143	1,775,705
	620	132	596	494.0	44.0	127.0	64	225	6.0	2,573	11,055	578,433	2,485,262
	710	185	680	530.0	67.0	178.0	89	236	7.5	6,810	26,500	1,530,949	5,957,437
420	650	140	626	520.0	48.0	135.0	68	235	6.0	3,142	13,146	706,349	2,955,338
	730	185	700	546.0	67.0	178.0	89	244	7.5	5,649	22,400	1,269,945	5,035,720
440	680	145	655	546.0	49.0	140.0	70	245	6.0	3,772	13,368	847,979	3,005,245
	780	206	745	576.0	74.0	199.0	100	260	9.5	6,278	24,649	1,411,350	5,541,315
480	650	103	635	554.0	33.0	99.0	55	259	6.0	1,920	11,000	431,633	2,472,898
500	670	103	654	574.0	33.0	99.0	55	268	5.0	2,404	12,124	540,440	2,725,583
	750	150	725	611.0	51.0	144.0	74	280	6.0	4,216	18,655	947,794	4,193,810
530	800	160	772	648.0	54.0	154.0	76	295	7.5	5,130	22,730	1,153,269	5,109,907
600	900	180	850	731.0	64.5	171.0	87	335	7.5	6,800	31,500	1,528,700	7,081,481
630	850	132	820	724.0	42.0	127.0	67	338	6.0	4,250	22,500	955,438	5,058,201
800	1360	335	1300	1040.0	120.0	324.0	162	462	15.0	16,340	72,364	3,678,378	16,268,074

N

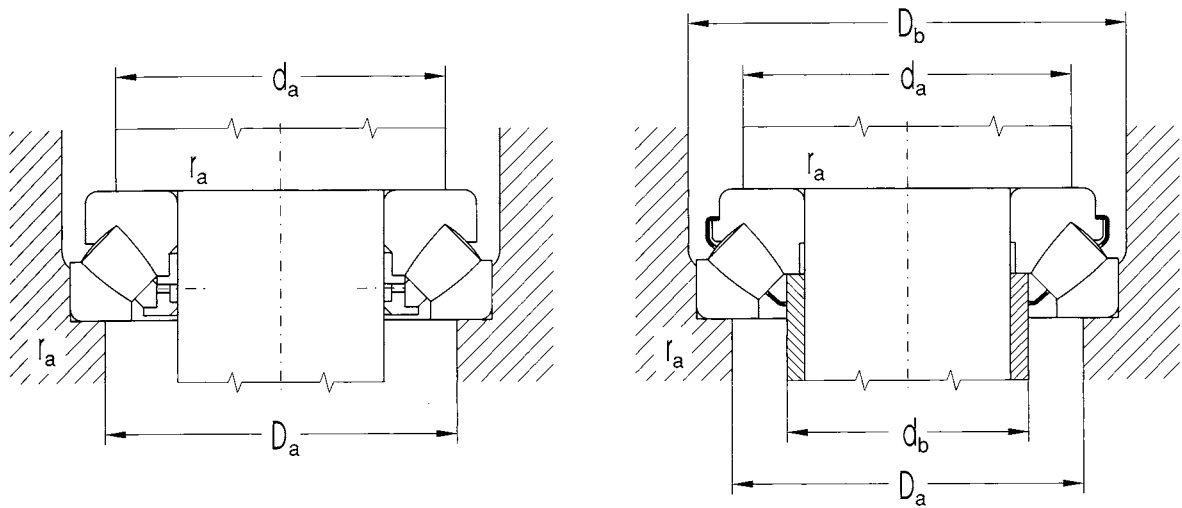

Limiting Speed for Lubrication with Oil rpm	Bearing Designation	Abutment and Fillet Dimensions						Weight M kg	Minimum Axial Load Factor
		d	d _a min	d _b max	D _a max	D _b min	r _a max		
600	29280M	400	460	-	500	-	3.0	55.3	7.0
500	29380M		498	-	557	-	5.0	150.0	24.0
450	29480EM		550	-	615	-	6.0	306.0	88.0
450	29384M	420	523	-	585	-	5.0	170.0	26.0
400	29484M		592	-	684	-	8.0	323.0	64.0
450	29388M	440	548	-	614	-	5.0	190.0	34.0
400	29488M		592	-	684	-	8.0	407.0	83.0
500	29296M	480	558	-	603	-	4.0	96.5	15.0
470	292/500M	500	578	-	622	-	4.0	101.0	16.0
400	293/500M		613	-	680	-	5.0	220.0	46.0
380	293/530M	530	651	-	724	-	6.0	286.0	64.0
330	293/600M	600	735	-	815	-	6.0	390.0	120.0
350	292/630M	630	730	-	789	-	5.0	211.0	44.0
220	294/800M	800	1055	-	1200	-	12.0	2010.0	740.0

N

This page left blank intentionally.

Insert Ball Bearings and Insert Ball Bearing Units



Insert ball bearings are single row deep groove ball bearings that are sealed on both sides. The outer ring has a spherical surface, which allows it to tilt in the housing and allows the bearing to withstand minor misalignments. These bearings have an extended inner ring and are mounted to the shaft by means of an eccentric locking collar (design UA or UE), set screws (design UC or US), or press fit (design UD). Like all double-sealed bearings they are filled with appropriate grease and are lubricated for the life of the bearing. Some housings allow for re-lubrication of the bearings by means of a special grease fitting.

These housings are produced from gray cast iron or steel sheet metal in two primary designs: pillow block (designation SG and SA) and flanged (designation FG, FM, FB, and FE). The housings are produced with a special spherical cavity where the insert ball bearings fit. These units are used in agricultural machines, transportation equipment, food-making machines, etc.

Cage

The insert ball bearings are produced with pressed steel cages.

Boundary Dimensions

Boundary dimensions of insert ball bearings comply with standard ISO 2264 and ISO 3228. The bearing housings and eccentric locking collars comply with standard ISO 3145.

Tolerance

Insert ball bearings are produced to the same tolerance specifications as single row deep groove ball bearings.

Radial Clearance

Insert ball bearings are produced to a normal or C0 radial clearance. Values of the radial clearance are the same as a standard ball bearing of the same dimensions. Bearings with other radial clearances may be produced upon request.

Limiting Rotational Speed

This parameter is dependent on the shaft fit of the bearing. The values are shown in the dimension tables.

Designation

The designation of insert ball bearings and corresponding housings are listed in the dimension tables.

0

Insert Ball Bearings

d = 25 to 40 mm

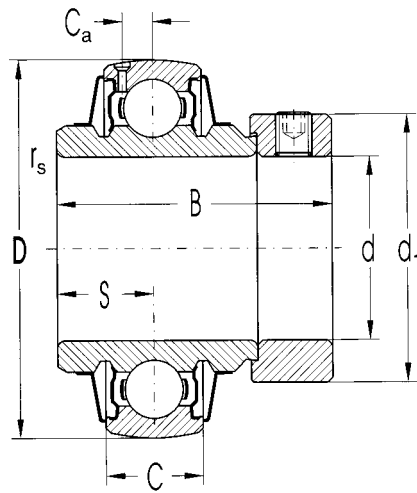

UA

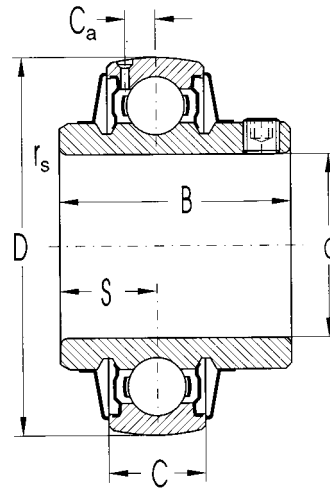

UC

Dimension								Basic Load Rating			
d	D	B	C	r _s min	d ₁ max	S	C _a	Dynamic C _r	Static C _{0r}	Dynamic C _r	Static C _{0r}
mm								kN	kN	lbs.	lbs.
25	52	44.4	15	1.0	38.0	17.5	4.1	14.0	7.90	3,147	1,776
	52	34.1	15	1.0	-	14.3	4.1	14.0	7.90	3,147	1,776
	52	-	15	1.0	-	7.5	-	14.0	7.90	3,147	1,776
	52	31.0	15	0.6	38.0	7.5	-	14.0	7.90	3,147	1,776
	52	27.7	15	1.0	-	7.5	-	14.0	7.90	3,147	1,776
30	62	48.4	16	1.0	45.0	18.3	4.8	19.4	11.20	4,361	2,518
	62	38.1	16	1.0	-	15.9	4.8	19.4	11.20	4,361	2,518
	62	-	16	1.0	-	8.0	-	19.4	11.20	4,361	2,518
	62	35.7	16	0.6	45.0	8.0	-	19.4	11.20	4,361	2,518
	62	30.3	16	1.0	-	8.0	-	19.4	11.20	4,361	2,518
35	72	51.1	17	1.1	56.5	18.8	5.3	25.6	15.20	5,755	3,417
	72	42.9	17	1.1	-	17.5	5.3	25.6	15.20	5,755	3,417
	72	-	17	1.1	-	8.5	-	25.6	15.20	5,755	3,417
	72	38.9	17	0.6	56.5	9.5	-	25.6	15.20	5,755	3,417
	72	34.0	17	1.1	-	8.5	-	25.6	15.20	5,755	3,417
40	80	56.3	18	1.1	60.0	21.4	5.9	32.6	19.80	7,329	4,451
	80	49.2	18	1.1	-	19.0	5.9	32.6	19.80	7,329	4,451
	80	-	18	1.1	-	9.0	-	32.6	19.80	7,329	4,451
	80	43.7	18	0.6	60.0	11.0	-	32.6	19.80	7,329	4,451
	80	39.5	18	1.1	-	9.0	-	32.6	19.80	7,329	4,451

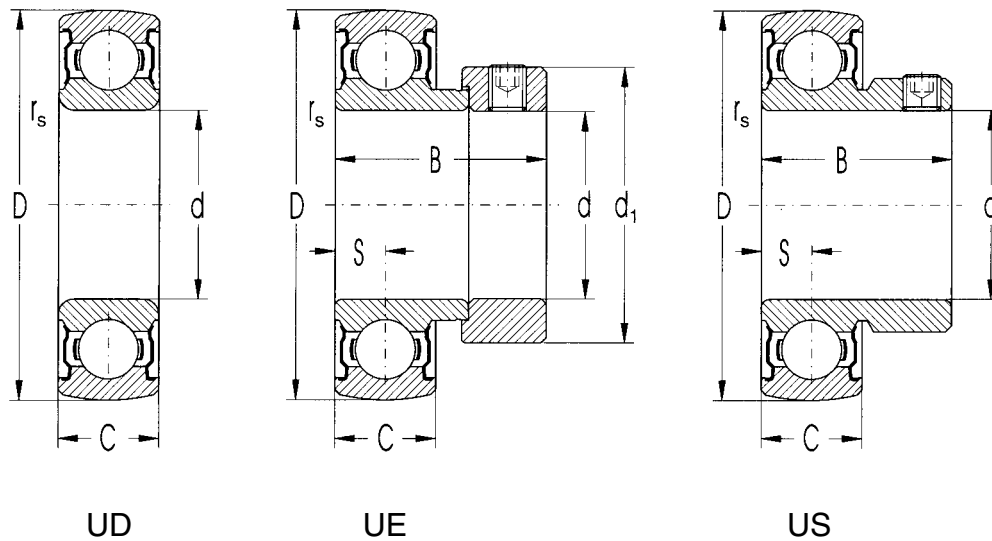

Bearing Designation	Weight	Limiting Speed for Lubrication with Grease				
		Shaft Diameter Tolerance				
		h6	h7	h8	h9	h11
kg	rpm					
UA205	0.230	7,100	4,500	3,200	1,000	710
UC205	0.170	7,100	4,500	3,200	1,000	710
UD205	0.126	-	-	-	-	-
UE205	0.180	7,100	4,500	3,200	1,000	710
US205	0.150	7,100	4,500	3,200	1,000	710
UA206	0.360	6,300	4,000	2,800	890	630
UC206	0.280	6,300	4,000	2,800	890	630
UD206	0.195	-	-	-	-	-
UE206	0.280	6,300	4,000	2,800	890	630
US206	0.210	6,300	4,000	2,800	890	630
UA207	0.550	5,300	3,300	2,200	750	530
UC207	0.410	5,300	3,300	2,200	750	530
UD207	0.278	-	-	-	-	-
UE207	0.420	5,300	3,300	2,200	750	530
US207	0.330	5,300	3,300	2,200	750	530
UA208	0.700	4,700	3,000	1,900	670	470
UC208	0.550	4,700	3,000	1,900	670	470
UD208	0.360	-	-	-	-	-
UE208	0.570	4,700	3,000	1,900	670	470
US208	0.450	4,700	3,000	1,900	670	470



Pillow Block Units with Insert Ball Bearings

d = 25 to 40 mm

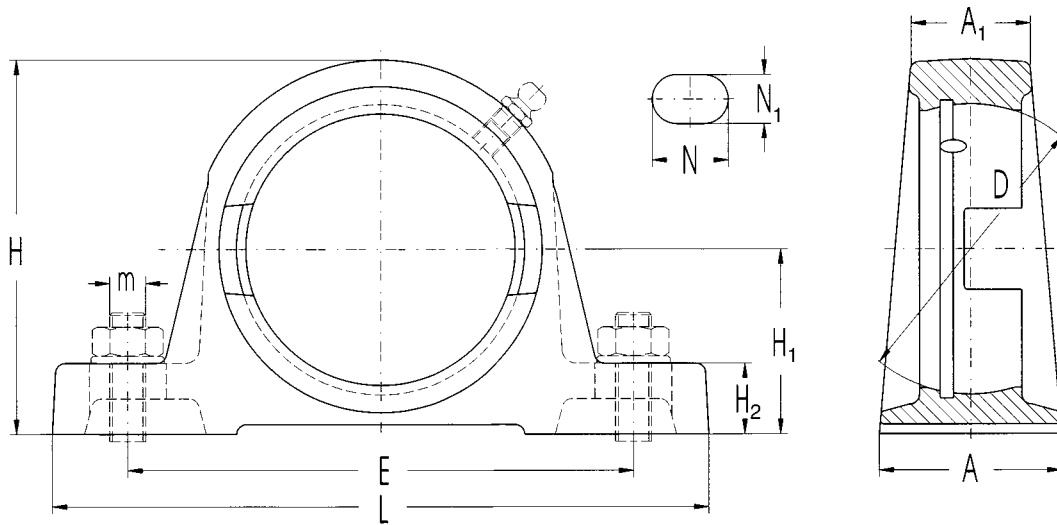

SG

Dimension									
d	D	L	E	A	A ₁	A ₂	A ₃	N	m
mm									
25	52	95	70.0	45.9	29.5	13	19.0	12	M10
	52	95	70.0	38.8	29.5	13	19.0	12	M10
30	62	108	82.5	50.1	31.0	13	20.0	12	M10
	62	108	82.5	42.2	31.0	13	20.0	12	M10
35	72	118	92.0	52.8	33.5	14	20.5	15	M12
	72	118	92.0	45.9	33.5	14	20.5	15	M12
40	80	130	101.5	57.9	36.5	14	23.0	15	M12
	80	130	101.5	53.5	36.5	14	23.0	15	M12

When using bearings - type **UE** into housings **SG** designation of units is **SGE**

When using bearings - type **US** into housings **SG** designation of units is **SGS**

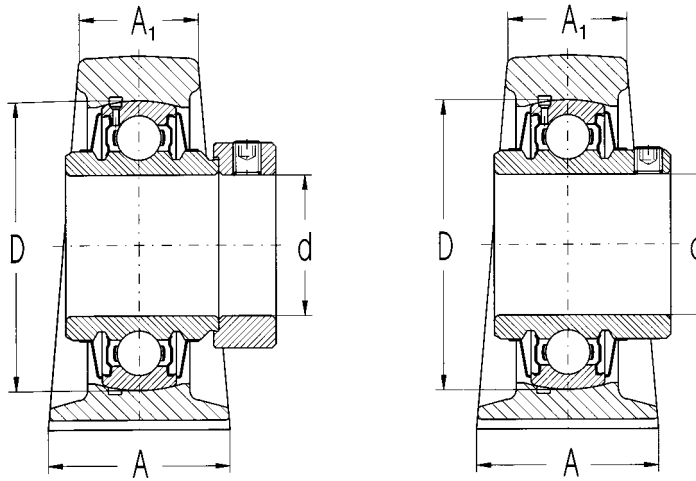

SGA

SGC

Basic Load Rating				Designation of			Weight
Dynamic C_r kN	Static C_{or} kN	Dynamic C_r lbs.	Static C_{or} lbs.	Unit	Housing	Bearing	
14.0	7.90	3,147	1,776	SGA205	SG205	UA205	0.74
14.0	7.90	3,147	1,776	SGC205	SG205	UC205	0.68
19.4	11.20	4,361	2,518	SGA206	SG206	UA206	1.20
19.4	11.20	4,361	2,518	SGC206	SG206	UC206	1.12
25.6	15.20	5,755	3,417	SGA207	SG207	UA207	1.60
25.6	15.20	5,755	3,417	SGC207	SG207	UC207	1.46
32.6	19.80	7,329	4,451	SGA208	SG208	UA208	1.95
32.6	19.80	7,329	4,451	SGC208	SG208	UC208	1.80



Pillow Block Units with Insert Ball Bearings

d = 25 to 40 mm

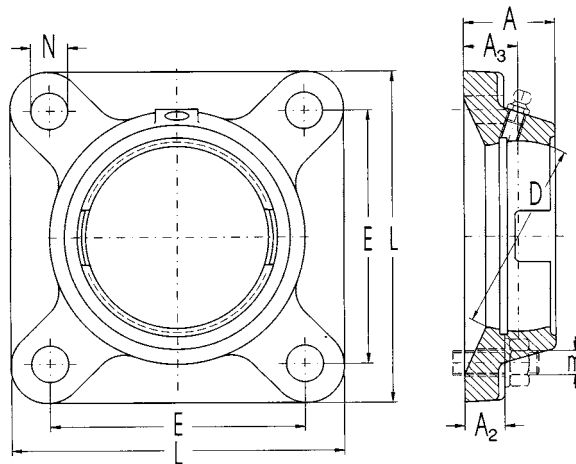

FG

Dimension									
d	D	L	E	A	A ₁	A ₂	A ₃	N	m
mm									
25	52	95	70.0	45.9	29.5	13	19.0	12	M10
	52	95	70.0	38.8	29.5	13	19.0	12	M10
30	62	108	82.5	50.1	31.0	13	20.0	12	M10
	62	108	82.5	42.2	31.0	13	20.0	12	M10
35	72	118	92.0	52.8	33.5	14	20.5	15	M12
	72	118	92.0	45.9	33.5	14	20.5	15	M12
40	80	130	101.5	57.9	36.5	14	23.0	15	M12
	80	130	101.5	53.5	36.5	14	23.0	15	M12

When using bearings - type **UE** into housings **FG** designation of units is **FGE**

When using bearings - type **UD** into housings **FG** designation of units is **FGD**

When using bearings - type **US** into housings **FG** designation of units is **FGS**

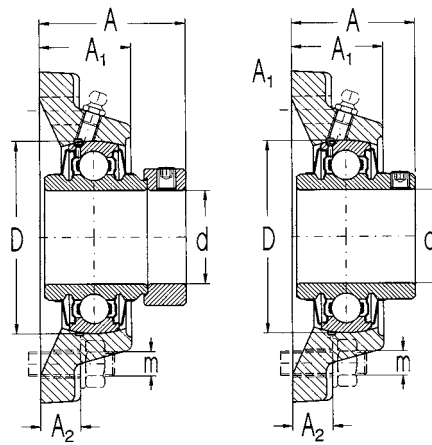

FGA

FGC

Basic Load Rating				Weight	Designation of		
Dynamic C_r kN	Static C_{or} kN	Dynamic C_r lbs.	Static C_{or} lbs.		Unit	Housing	Bearing
14.0	7.9	3,147	1,776	0.83	FGA205	FG205	UA205
14.0	7.9	3,147	1,776	0.77	FGC205	FG205	UC205
19.4	11.2	4,361	2,518	1.20	FGA206	FG206	UA206
19.4	11.2	4,361	2,518	1.12	FGC206	FG206	UC206
25.6	15.2	5,755	3,417	1.55	FGA207	FG207	UA207
25.6	15.2	5,755	3,417	1.41	FGC207	FG207	UC207
32.6	19.8	7,329	4,451	2.05	FGA208	FG208	UA208
32.6	19.8	7,329	4,451	1.90	FGC208	FG208	UC208



Oval Flanged Units with Insert Ball Bearings

d = 25 to 40 mm

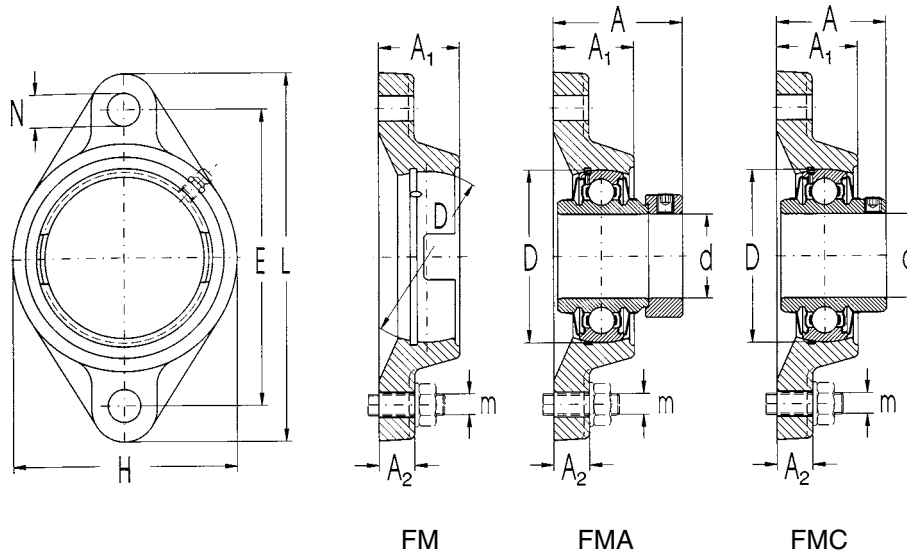

Dimension									
d	D	L	H	E	A	A ₁	A ₂	N	m
mm									
25	52	123	70	99.0	45.9	29.5	13	12	M10
	52	123	70	99.0	38.8	29.5	13	12	M10
30	62	142	83	116.5	50.1	31.0	13	12	M10
	62	142	83	116.5	42.2	31.0	13	12	M10
35	72	156	92	130.0	53.3	33.5	14	14	M12
	72	156	92	130.0	46.4	33.5	14	14	M12
40	80	172	102	143.8	58.9	37.0	14	15	M12
	80	172	102	143.8	54.2	37.0	14	15	M12

When using bearings - type **UE** into housings **FM** designation of units is **FME**

When using bearings - type **UD** into housings **FM** designation of units is **FMD**

When using bearings - type **US** into housings **FM** designation of units is **FMS**

Basic Load Rating				Designation of			Weight
Dynamic C_r	Static C_{or}	Dynamic C_r	Static C_{or}	Unit	Housing	Bearing	
kN	kN	lbs.	lbs.				kg
14.0	7.9	3,147	1,776	FMA205	FM205	UA205	0.64
14.0	7.9	3,147	1,776	FMC205	FM205	UC205	0.58
19.4	11.2	4,361	2,518	FMA206	FM206	UA206	1.08
19.4	11.2	4,361	2,518	FMC206	FM206	UC206	1.00
25.6	15.2	5,755	3,417	FMA207	FM207	UA207	1.45
25.6	15.2	5,755	3,417	FMC207	FM207	UC207	1.31
32.6	19.8	7,329	4,451	FMA208	FM208	UA208	1.75
32.6	19.8	7,329	4,451	FMC208	FM208	UC208	1.60



Triangle Pressed Flanged Units with Insert Ball Bearings

d = 25 to 35 mm

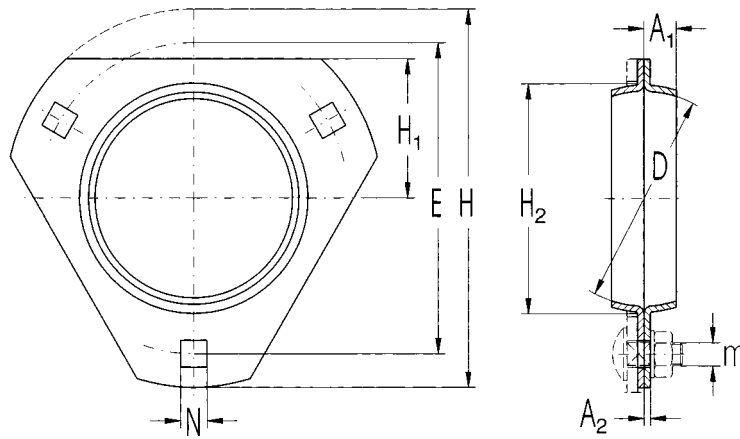

FB

Dimension										
d	D	H	E	H ₁	H ₂	A	A ₁	A ₂	N	m
mm										
25	52	99.5	76.0	34.5	60	26.9	9.0	2.0	8.8	M8
	52	99.5	76.0	34.5	60	19.8	9.0	2.0	8.8	M8
30	62	112.5	90.5	38.5	71	30.1	9.5	2.5	10.5	M10
	62	112.5	90.5	38.5	71	22.2	9.5	2.5	10.5	M10
35	72	122.0	100.0	45.0	81	32.3	10.0	2.5	10.5	M10
	72	122.0	100.0	45.0	81	24.1	10.0	2.5	10.5	M10

When using bearings - type **UE** into housings **FB** designation of units is **FBE**

When using bearings - type **UD** into housings **FB** designation of units is **FBD**

When using bearings - type **US** into housings **FB** designation of units is **FBS**

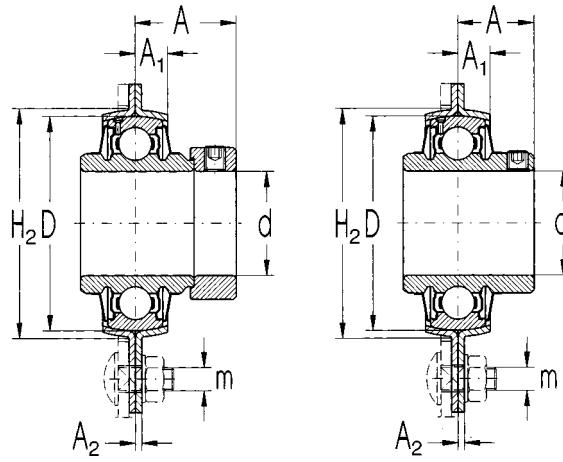

FBA

FBC

Basic Load Rating				Designation of			Weight
Dynamic C_r	Static C_{or}	Dynamic C_r	Static C_{or}	Unit	Housing	Bearing	
kN	kN	lbs.	lbs.				kg
14.0	7.9	3,147	1,776	FBA205	FB205	UA205	0.36
14.0	7.9	3,147	1,776	FBC205	FB205	UC205	0.30
19.4	11.2	4,361	2,518	FBA206	FB206	UA206	0.58
19.4	11.2	4,361	2,518	FBC206	FB206	UC206	0.50
25.6	15.2	5,755	3,417	FBA207	FB207	UA207	0.81
25.6	15.2	5,755	3,417	FBC207	FB207	UC207	0.67



Sheet Pillow Block Units with Insert Ball Bearings

d = 25 to 35 mm

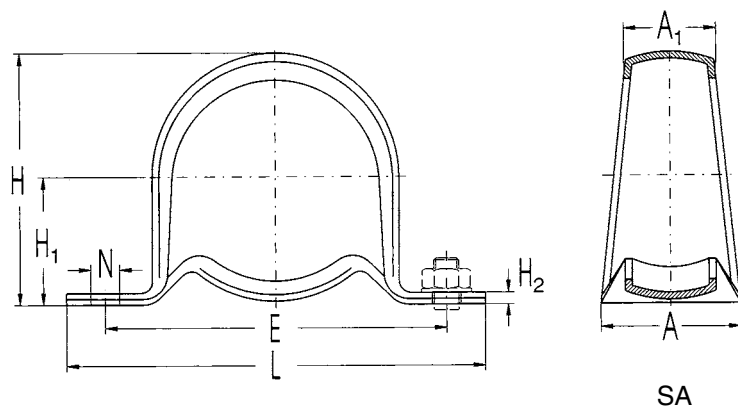

Dimension									
d	D	A	A ₁	E	L	H	H ₁	H ₂	N
mm									
25	52	32	21.5	86	108	56.6	28.6	4	11.2
30	62	38	23.8	95	119	66.3	33.3	4	11.2
35	72	42	27	106	130	78.2	39.7	5	11.2

In units **SAD** UD bearings are used

In units **SAE** UE bearings are used

In units **SAS** US bearings are used

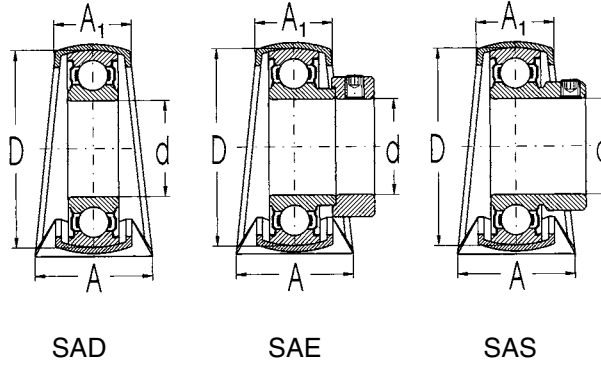

Basic Load Rating				Designation of				Weight
Dynamic C_r kN	Static C_{or} kN	Dynamic C_r lbs.	Static C_{or} lbs.	Housing	Housing with Bearing			
14	7.9	3,147	1,776	SA205	SAD205	SAE205	SAS205	0.13
19.4	11.2	4,361	2,518	SA206	SAD206	SAE206	SAS206	0.18
25.6	15.2	5,755	3,417	SA207	SAD207	SAE207	SAS207	0.23



This page left blank intentionally.

SAF Split Pillow Block Housings

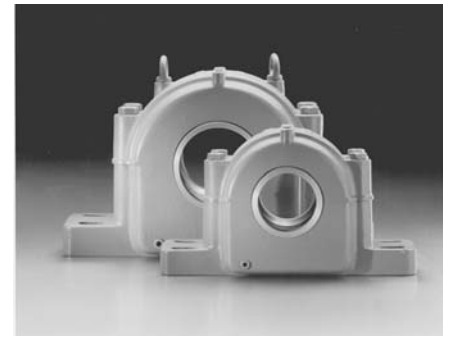

SAF split pillow block housings are cast and produced in accordance with standard ISO/R113 - 1994. They are horizontally split and are designed for use with spherical roller bearings or double row self-aligning ball bearings with a tapered bore and mounted on an adapter sleeve. The housings are available in both SAF and FSAF design. Listed below are the explanations to each letter:

SAF: **S** - Standard Pillow Block; **A** - Inch Dimension; **F** - Triple Ring Seal
FSAF: **F** - Four-Bolt Housing

Each housing has two or four slotted bolt holes. The slotted bolt holes in the housing base permit slight adjustments to be made to position the pillow block. The housing is fitted with dowel pins to ensure correct location of the associated caps and bases, which are not interchangeable. All SAF split pillow block housings come with labyrinth style seals. Standard end plugs are also available. Other seal and end plug designs may be available upon request.

The bearing seat of the housing is machined to tolerances so that a loose fit of the bearing outer ring is assured and, in most cases, the seating width allows the bearing to have axial freedom. Dimensional inaccuracies, slight positioning errors in mounting, and thermal expansion on the shaft can be accommodated in the pillow block housing itself. Stabilizing rings are provided at no extra cost for applications where a "fixed" bearing is required to maintain shaft location.

The pillow blocks are usually made of cast iron. For extra heavy duty applications, ductile iron or cast steel pillow blocks are available. Material selection should be based on careful analysis of the operational and environmental demands of the application. Due to their higher cost, ductile iron and cast steel should be chosen only where extreme conditions justify their use.

SAF 225 Series

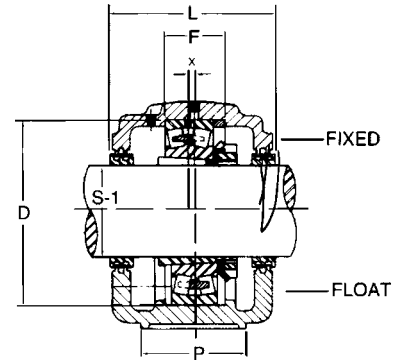
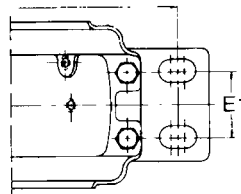
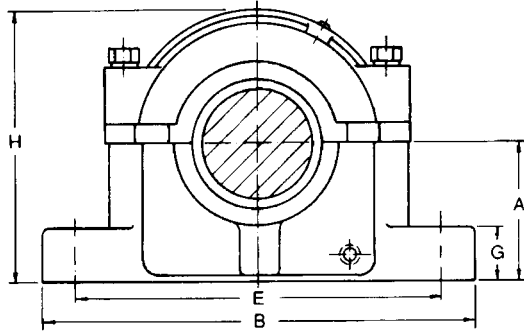

Series SAF 500 Housing Dimensions

Housing Number	A	B	P	G	E		E1	H	L	X	Bolts (No. Req'd.)	Weight In Lbs.	D	F
	in.	in.	in.	in.	max. in.	min. in.	in.	in.	in.	in.			in.	mm
SAF 509	2-1/4	8-1/4	2-3/8	13/16	7	6-1/4	-	4-3/8	3-5/8	0.114	(2)-1/2	9.3	85	29
SAF 510	2-1/2	8-1/4	2-3/8	15/16	7	6-1/2	-	4-3/4	3-5/8	0.133	(2)-1/2	10.2	90	30
SAF 511	2-3/4	9-5/8	2-3/4	15/16	7-7/8	7-3/8	-	5-1/4	3-7/8	0.114	(2)-5/8	12.5	100	31
SAF 513+	3	11	3-1/8	1	9-1/2	8-1/8	2	5-15/16	4-1/2	0.157	(2)-5/8 (4)-1/2	18.3	120	39
SAF 515+	3-1/4	11-1/4	3-1/8	1-1/8	9-5/8	8-5/8	1-7/8	6-3/8	4-3/4	0.118	(2)-5/8 (4)-1/2	18.3	130	37
SAF 516+	3-1/2	13	3-1/2	1-3/16	11	9-5/8	2-1/8	6-7/8	4-7/8	0.187	(2)-3/4 (4)-5/8	26.9	140	43
SAF 517+	3-3/4	13	3-1/2	1-1/4	11	9-7/8	2-1/8	7-5/16	5	0.187	(2)-3/4 (4)-5/8	29.8	150	46
SAF 518+	4	13-3/4	3-7/8	1-5/16	11-5/8	10-3/8	2-1/8	7-3/4	5-3/4	0.187	(2)-3/4 (4)-5/8	36.6	160	50
SAF 520+	4-1/2	15-1/4	4-3/8	1-3/4	13-1/8	11-5/8	2-3/8	8-3/4	6-1/8	0.187	(2)-5/8 (4)-3/4	50.2	180	56
SAF 522	4-15/16	16-1/2	4-3/4	2	14-1/2	12-5/8	2-3/4	9-5/8	6-1/2	0.187	(4)-3/4	60.1	200	63
SAF 524	5-1/4	16-1/2	4-3/4	2-1/8	14-1/2	13-1/4	2-3/4	10-1/4	7-3/8	0.187	(4)-3/4	71.2	215	68
SAF 526	6	18-3/8	5-1/8	2-3/8	16	14-5/8	3-1/4	11-1/2	8	0.187	(4)-7/8	94.7	230	74
SAF 528	6	20-1/8	5-7/8	2-3/8	17-1/8	16	3-3/8	11-3/4	7-5/8	0.187	(4)-1	110.2	250	78
SAF 530	6-5/16	21-1/4	6-1/4	2-1/2	18-1/4	17	3-3/4	12-1/2	8-3/8	0.187	(4)-1	137.9	270	83
SAF 532	6-11/16	22	6-1/4	2-5/8	19-1/4	17-3/8	3-3/4	13-5/16	8-3/4	0.187	(4)-1	157.6	290	90
SAF 534	7-1/16	24-3/4	6-3/4	2-3/4	21-5/8	19-3/8	4-1/4	14-3/16	9-5/8	0.187	(4)-1	184.6	310	96
SAF 536	7-1/2	26-3/4	7-1/8	3	23-5/8	20-7/8	4-5/8	14-7/18	10	0.187	(4)-1	217.1	320	96
SAF 538	7-7/8	28	7-1/2	3-1/8	24-3/8	21-5/8	4-1/2	15-11/16	10-3/4	0.187	(4)-1 1/4	285	340	102
SAF 540	8-1/4	29-1/2	8	3-3/8	25	22-1/2	5	16-1/2	11-1/4	0.187	(4)-1 1/4	330	360	108
SAF 544	9-1/2	32-3/4	8-3/4	3-3/4	27-7/8	24-3/4	5-1/4	18-5/8	12	0.187	(4)-1 1/2	391.3	400	111

P

NOTES:

- * Basic housing does not include bearing and accessories. The weight is subject to change.
- § For float unit application, order 1-housing, 1-bearing, 1-adapter, and 2-labyrinth seals. For fixed unit application, add 1-stabilizing ring to the above.
- + 4-hole base is also available and must be marked with a prefix F. SAF 522 and SAF 618 and up are standard 4-hole base.

Series SAF 225 Pillow Block Part Numbers

Shaft Dia. S-1 in.	Complete Pillow Block Number	Pillow Block Housing Only	Bearing Number	Adapter Assembly	Labyrinth Seal Ring (2 Req'd.)	Stabilizing Ring / Fixing Ring (1 Req'd.)	End Plug (EPR)
1-7/16	SAF 22509	SAF 509	22209K	SNW 09 HA309	LER 17	SR 9-9 85/5.8	3
1-11/16	SAF 22510	SAF 510	22210K	SNW 10 HA310	LER 20	SR 10-0 90/6.8	4
1-15/16	SAF 22511	SAF 511	22211K	SNW 11 HA311	LER 24	SR 11-0 100/5.8	5
2-3/16	SAF 22513	SAF 513	22213K	SNW 13 HA313	LER 29	SR 13-0 120/8	6
2-7/16	SAF 22515	SAF 515	22215K	SNW 15 HA315	LER 37	SR 15-0 130/6	7
2-11/16	SAF 22516	SAF 516	22216K	SNW 16 HA316	LER 44	SR 16-13 140/9.8	8
2-15/16	SAF 22517	SAF 517	22217K	SNW 17 HA317	LER 53	SR 17-14 150/9.8	9
3-3/16	SAF 22518	SAF 518	22218K	SNW 18 HA318	LER 188	SR 18-15 160/9.8	11
3-7/16	SAF 22520	SAF 520	22220K	SNW 20 HA320	LER 102	SR 20-17 180/9.8	12
3-15/16	SAF 22522	SAF 522	22222K	SNW 22 HA322	LER 109	SR 22-19 200/9.8	13
4-3/16	SAF 22524	SAF 524	22224K	SNW 24	LER 113	SR 24-20 215/9.8	14
4-7/16	SAF 22526	SAF 526	22226K	SNW 26 HA3126	LER 117	SR 26-0 230/9.8	15
4-15/16	SAF 22528	SAF 528	22228K	SNW 28 HA3128	LER 122	SR 28-0 250/9.8	27
5-3/16	SAF 22530	SAF 530	22230K	SNW 30	LER 125	SR 30-0 270/9.8	16
5-7/16	SAF 22532	SAF 532	22232K	SNW 32 HA3132	LER 130	SR 32-0 290/9.8	16
5-15/16	SAF 22534	SAF 534	22234K	SNW 34 HA3134	LER 140	SR 34-0 310/9.8	18
6-7/16	SAF 22536	SAF 536	22236K	SNW 36 HA3136	LER 148	SR 36-30 320/9.8	19
6-15/16	SAF 22538	SAF 538	22238K	SNW 38 HA3138	LER 155	SR 38-32 340/9.8	20
7-3/16	SAF 22540	SAF 540	22240K	SNW 40	LER 159	SR 40-34 360/9.8	21
7-15/16	SAF 22544	SAF 544	22244K	SNW 44 HA3144	LER 167	SR 44-38 400/9.8	23

P

SAF 226 Series

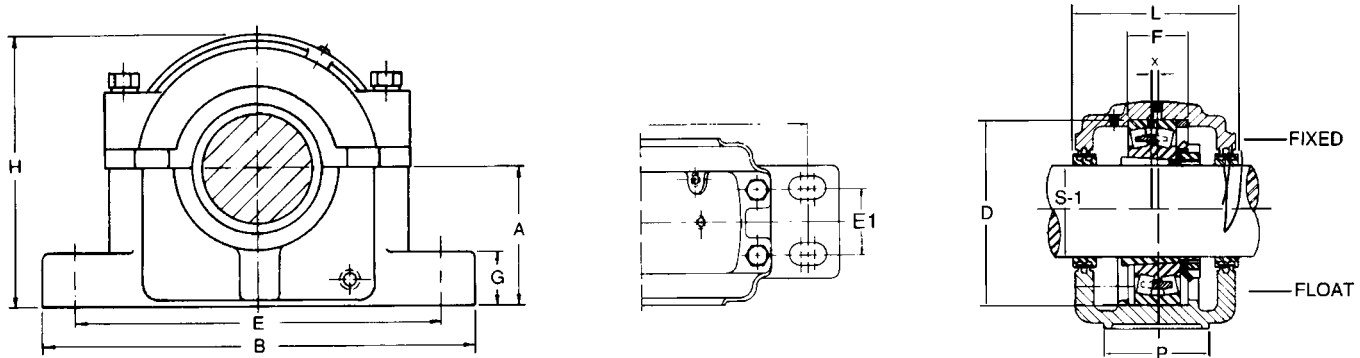

Series SAF 300 Housing Dimensions

Housing Number	A	B	P	G	E		E1	H	L	Bolts (No. Req'd.)	Weight In Lbs. *	D	F
	in.	in.	in.	in.	max. in.	min. in.	in.	in.	in.			in.	mm
SAF 609	2-3/4	9-5/8	2-3/4	1	7-7/8	7-3/8	-	5-5/16	4-1/4	(2)-5/8	12.1	100	46
SAF 610	3	10-5/8	2-3/4	1-1/8	9	7-3/4	-	5-13/16	4-5/8	(2)-5/8	16.8	110	51
SAF 611+	3-1/4	11	3-1/3	1-3/16	9-1/2	8-1/8	2	6-3/16	4-7/8	(2)-5/8 (4)-1/2	20.2	120	53
SAF 613+	3-1/2	13	3-1/2	1-1/4	11	9-5/8	2-1/8	6-15/16	5-3/8	(2)-3/4 (4)-5/8	28.7	140	58
SAF 615+	4	13-3/4	3-7/8	1-5/16	11-5/8	10-3/8	2-1/8	7-3/4	6-1/4	(2)-3/4 (4)-5/8	36.9	160	65
SAF 616+	4-1/4	14-1/4	3-7/8	1-5/16	12-5/8	10-5/8	2-1/8	8-1/4	6-1/2	(2)-3/4 (4)-5/8	47.6	170	68
SAF 617+	4-1/2	15-1/4	4-3/8	1-3/4	13-1/8	11-5/8	2-3/8	8-3/4	6-3/4	(2)-7/8 (4)-3/4	57.4	180	70
SAF 618	4-3/4	15-1/2	4-3/8	2	13-1/2	12	2-1/4	9-3/16	6-7/8	(4)-3/4	62.8	190	74
SAF 620	5-1/4	16-1/2	4-3/4	2-1/8	14-1/2	13-1/4	2-3/4	10-1/4	7-3/8	(4)-3/4	77.1	215	83
SAF 622	6	18-3/8	5-1/8	2-3/8	16	14-5/8	3	11-1/2	8	(4)-7/8	107.4	240	90
SAF 624	6-5/16	21-1/4	6-1/4	2-1/2	18-1/4	17	3-3/4	12-1/2	8-3/8	(4)-1	145.9	260	96
SAF 626	6-11/16	22	6-1/4	2-5/8	19-1/4	17-3/8	3-3/4	13-5/16	8-3/4	(4)-1	164.7	280	103
SAF 628	7-1/16	24-3/4	6-3/4	2-3/4	21-5/8	19-3/8	4-1/4	14-3/16	9-5/8	(4)-1	192.9	300	112
SAF 630	7-1/2	26-3/4	7-1/8	3	23-5/8	20-7/8	4-5/8	14-7/8	9-3/4	(4)-1	259.5	320	118
SAF 632	7-7/8	28	7-1/2	3-1/8	24-3/8	21-5/8	4-1/2	15-11/16	10-3/4	(4)-1 1/4	268.9	340	124
SAF 634	8-1/4	29-1/2	8	3-3/8	25	22-1/2	5	16-1/2	11-1/4	(4)-1 1/4	306.4	360	130
SAF 636	8-7/8	31-1/4	8-1/4	3-1/2	26-5/8	24	5-1/4	17-3/4	11-3/8	(4)-1 1/4	374.8	380	136
SAF 638	9-1/2	32-3/4	8-3/4	3-3/4	27-7/8	24-3/4	5-1/4	18-5/8	12	(4)-1 1/2	441	400	142
SAF 640	9-7/8	34-1/4	9	4	29-1/2	26-1/4	5-1/2	20	12-1/16	(4)-1 1/2	489.9	420	148

NOTES:

- * Basic housing does not include bearing and accessories. The weight is subject to change.
- § For float unit application, order 1-housing, 1-bearing, 1-adapter, and 2-labyrinth seals. For fixed unit application, add 1-stabilizing ring to the above.
- + 4-hole base is also available and must be marked with a prefix F. SAF 522 and SAF 618 and up are standard 4-hole base.

Series SAF 226 Pillow Block Part Numbers

Shaft Dia. S-1 in.	Complete Pillow Block Number	Pillow Block Housing Only	Bearing Number	Adapter Assembly	Labyrinth Seal Ring (2 Req'd.)	Stabilizing Ring / Fixing Ring (1 Req'd.)	End Plug (EPR)
1-7/16	SAF 22609	SAF 609	22309K	SNW 109 HA2309	LER 17	SR 11-9 100/9.8	3
1-11/16	SAF 22610	SAF 610	22310K	SNW 110 HA2310	LER 20	SR 0-10 110/10.8	4
1-15/16	SAF 22611	SAF 611	22311K	SNW 111 HA2311	LER 24	SR 13-11 120/9.8	5
2-3/16	SAF 22613	SAF 613	22313K	SNW 113 HA2313	LER 32	SR 16-13 140/9.8	6
2-7/16	SAF 22615	SAF 615	22315K	SNW 115 HA2315	LER 37	SR 18-15 160/9.8	7
2-11/16	SAF 22616	SAF 616	22316K	SNW 116 HA2316	LER 44	SR 19-16 170/9.8	8
2-15/16	SAF 22617	SAF 617	22317K	SNW 117 HA2317	LER 184	SR 20-17 180/9.8	10
3-3/16	SAF 22618	SAF 618	22318K	SNW 118 HA2318	LER 188	SR 21-18 190/9.8	11
3-7/16	SAF 22620	SAF 620	22320K	SNW 120 HA2320	LER 102	SR 24-20 215/9.8	12
3-15/16	SAF 22622	SAF 622	22322K	SNW 122 HA2322	LER 109	SR 0-22 240/9.8	13
4-3/16	SAF 22624	SAF 624	22324K	SNW 124 HA2324	LER 113	SR 0-24 260/9.8	14
4-7/16	SAF 22626	SAF 626	22326K	SNW 126 HA2326	LER 117	SR 0-26 280/9.8	15
4-15/16	SAF 22628	SAF 628	22328K	SNW 128 HA2328	LER 122	SR 0-28 300/9.8	27
5-3/16	SAF 22630	SAF 630	22330K	SNW 130 HA2330	LER 125	SR 36-30 320/9.8	16
5-7/16	SAF 22632	SAF 632	22332K	SNW 132 HA2332	LER 130	SR 38-32 340/9.8	16
5-15/16	SAF 22634	SAF 634	22334K	SNW 134 HA2334	LER 140	SR 40-34 360/9.8	18
6-7/16	SAF 22636	SAF 636	22336K	SNW 136 HA2336	LER 148	SR 0-36 380/9.8	19
6-15/16	SAF 22638	SAF 638	22338K	SNW 138 HA2338	LER 155	SR 44-38 400/9.8	20
7-3/16	SAF 22640	SAF 640	22340K	SNW 140 -	LER 159	SR 0-40 420/9.8	21

P

SAF 222 Series

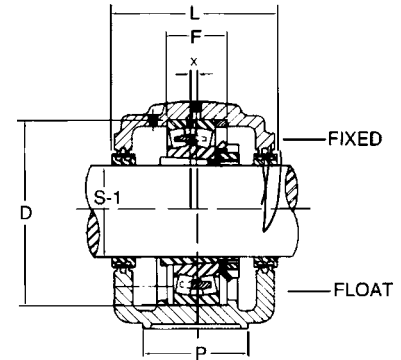
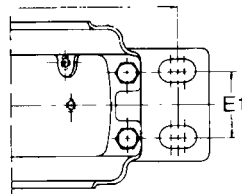
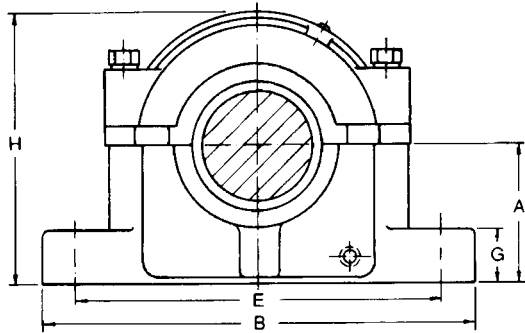

Series SAF 200 Housing Dimensions

Housing Number	A	B	P	G	E		E1	H	L	Bolts (No. Req'd.)	Weight In Lbs.	D	F
	in.	in.	in.	in.	max. in.	min. in.	in.	in.	in.			in.	mm
SAF 216+	3-1/2	13	3-1/2	1-1/4	11	9-5/8	2-1/8	6-15/16	5-3/8	(2)-3/4 (4)-5/8	22.9	140	43
SAF 217+	3-3/4	13	3-1/2	1-1/4	11	9-7/8	2-1/8	7-3/8	5-3/8	(2)-3/4 (4)-5/8	28.6	150	46
SAF 218+	4	13-3/4	3-7/8	1-5/16	11-5/8	10-3/8	2-1/8	7-3/4	5-3/4	(2)-3/4 (4)-5/8	34.5	160	50
SAF 220+	4-1/2	15-1/4	4-3/8	1-3/4	13-1/8	11-5/8	2-3/8	8-3/4	6	(2)-7/8 (4)-3/4	50.7	180	56
SAF 222	4-15/16	16-1/2	4-3/4	2	14-1/2	12-5/8	2-3/4	9-5/8	6-1/2	(4)-3/4	64.8	200	63
SAF 224	5-1/4	16-1/2	4-3/4	2-1/8	14-1/2	13-1/4	2-3/4	10-1/4	7-3/8	(4)-3/4	68.3	215	68
SAF 226	6	18-3/8	5-1/8	2-3/8	16	14-5/8	3-1/4	11-1/2	8	(4)-7/8	103.1	230	74
SAF 228	6	20-1/8	5-7/8	2-3/8	17-1/8	16	3-3/8	11-3/4	7-5/8	(4)-1	113.1	250	78
SAF 230	6-5/16	21-1/4	6-1/4	2-1/2	18-1/4	17	3-3/4	12-1/2	8-3/8	(4)-1	146.7	270	83
SAF 232	6-11/16	22	6-1/4	2-5/8	19-1/4	17-3/8	3-3/4	13-5/16	8-3/4	(4)-1	169.7	290	90
SAF 234	7-1/16	24-3/4	6-3/4	2-3/4	21-5/8	19-3/8	4-1/4	14-3/16	9-5/8	(4)-1	179.3	310	96
SAF 236	7-1/2	26-3/4	7-18	3	23-5/8	20-7/8	4-5/8	14-7/8	10	(4)-1	212.1	320	96
SAF 238	7-7/8	28	7-1/2	3-1/8	24-3/8	21-5/8	4-1/2	15-11/16	10-3/4	(4)-1 1/4	284.8	340	102
SAF 240	8-1/4	29-1/2	8	3-3/8	25	22-1/2	5	16-1/2	11-1/4	(4)-1 1/4	342.3	360	108
SAF 244	9-1/2	32-3/4	8-3/4	3-3/4	27-7/8	24-3/4	5-1/4	18-5/8	12	(4)-1 1/2	426.5	400	118

P

NOTES:

- * Basic housing does not include bearing and accessories. The weight is subject to change.
- § For float unit application, order 1-housing, 1-bearing, 1-adapter, and 2-labyrinth seals. For fixed unit application, add 1-stabilizing ring to the above.
- + 4-hole base is also available and must be marked with a prefix F. SAF 522 and SAF 618 and up are standard 4-hole base.

Series SAF 222 Pillow Block Part Numbers

Shaft Diameter		Complete Pillow Block Number	Pillow Block Housing Only	Bearing Number	Locknut	Lockwasher	Labyrinth Seal Ring		Stabilizing Ring / Fixing Ring (1 Req'd.)	End Plug (EPR)
S-2 in.	S-3 in.						S-2 Shaft (1 Req'd.)	S-3 Shaft (1 Req'd.)		
3-5/8	3	SAF 22216	SAF 216	22216	AN 16	W 16	LER 82	LER 54	SR 16-13 140/9.8	9
3-15/16	3-3/16	SAF 22217	SAF 217	22217	AN 17	W 17	LER 89	LER 63	SR 17-14 150/9.8	9
4-1/8	3-3/8	SAF 22218	SAF 218	22218	AN 18	W 18	LER 112	LER 91	SR 18-15 160/9.8	11
4-1/2	3-13/16	SAF 22220	SAF 220	22220	AN 20	W 20	LER 118	LER 106	SR 20-17 180/9.8	12
4-7/8	4-3/16	SAF 22222	SAF 222	22222	AN 22	W 22	LER 121	LER 113	SR 22-19 200/9.8	14
5-5/16	4-9/16	SAF 22224	SAF 224	22224	AN 24	W 24	LER 127	LER 119	SR 24-20 215/9.8	15
5-7/8	4-15/16	SAF 22226	SAF 226	22226	AN 26	W 26	LER 136	LER 122	SR 26-0 230/9.8	27
6-1/4	5-5/16	SAF 22228	SAF 228	22228	AN 28	W 28	LER 144	LER 127	SR 28-0 250/9.8	16
6-5/8	5-3/4	SAF 22230	SAF 230	22230	AN 30	W 30	LER 151	LER 134	SR 30-0 270/9.8	17
7	6-1/16	SAF 22232	SAF 232	22232	AN 32	W 32	LER 156	LER 142	SR 32-0 290/9.8	18
7-7/16	6-7/16	SAF 22234	SAF 234	22234	AN 34	W 34	LER 161	LER 148	SR 34-0 310/9.8	19
7-13/16	6-7/8	SAF 22236	SAF 236	22236	AN 36	W 36	LER 165	LER 154	SR 36-30 320/9.8	20
8-3/8	7-1/4	SAF 22238	SAF 238	22238	AN 38	W 38	LER 171	LER 160	SR 38-32 340/9.8	21
8-3/4	7-5/8	SAF 22240	SAF 240	22240	AN 40	W 40	LER 175	LER 164	SR 40-34 360/9.8	22
9-9/16	8-5/16	SAF 22244	SAF 244	22244	AN 44	W 44	LER 179	LER 170	SR 44-38 400/9.8	24

P

SAF 223 Series

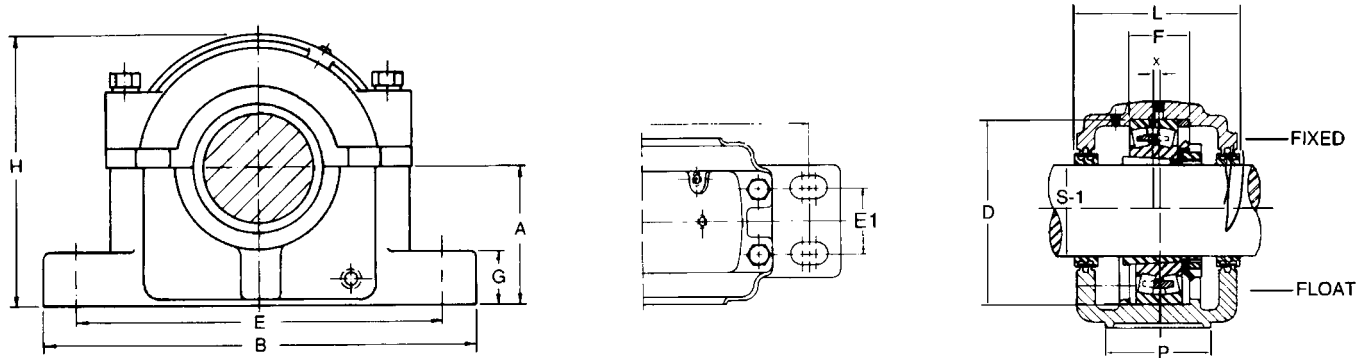

Series SAF 300 Housing Dimensions

Housing Number	A	B	P	G	E		E1	H	L	Bolts (No. Req'd.)	Weight In Lbs.	D	F
	in.	in.	in.	in.	max. in.	min. in.	in.	in.	in.			mm	mm
SAF 308	2-1/2	8-1/4	2-3/8	1	7	6-1/2	-	4-13/16	4	(2)-1/2	11.2	90	42.8
SAF 309	2-3/4	9-5/8	2-3/4	1	7-7/8	7-3/8	-	5-5/16	4-1/4	(2)-5/8	14.3	100	46
SAF 310	3	10-5/8	2-3/4	1-1/8	9	7-3/4	-	5-13/16	4-5/8	(2)-5/8	17.8	110	51
SAF 311+	3-1/4	11	3-1/8	1-3/16	9-1/2	8-1/8	2	6-3/16	5	(2)-5/8 (4)-1/2	20.2	120	53
SAF 313+	3-1/2	13	3-1/2	1-1/4	11	9-5/8	2-1/8	6-15/16	5-3/8	(2)-3/4 (4)-5/8	28.6	140	58
SAF 315	4	13-3/4	3-7/8	1-5/16	11-5/8	10-3/8	2-1/8	7-13/16	6-1/4	(2)-3/4 (4)-5/8	39.6	160	65
SAF 316	4-1/4	14-1/4	3-7/8	1-5/16	12-5/8	10-5/8	2-1/8	8-1/4	6-1/2	(2)-3/4 (4)-5/8	49.8	170	68
SAF 317	4-1/2	15-1/4	4-3/8	1-3/4	13-1/8	11-5/8	2-3/8	8-3/4	6-3/4	(2)-7/8 (4)-3/4	53.7	180	70
SAF 318	4-3/4	15-1/2	4-3/8	2	13-1/2	12	2-1/4	9-3/16	6-7/8	(4)-3/4	59	190	74
SAF 320	5-1/4	16-1/2	4-3/4	2-1/8	14-1/2	13-1/4	2-3/4	10-1/4	7-3/8	(4)-3/4	81.3	215	83
SAF 322	6	18-3/8	5-1/8	2-3/8	16	14-5/8	3-1/4	11-1/2	8	(4)-7/8	96.5	240	90
SAF 324	6-5/16	21-1/4	6-1/4	2-1/2	18-1/4	17	3-3/4	12-1/2	8-3/8	(4)-1	142.1	260	96
SAF 326	6-11/16	22	6-1/4	2-5/8	19-1/4	17-3/8	3-3/4	13-5/16	8-3/4	(4)-1	176.3	280	103
SAF 328	7-1/16	24-3/4	6-3/4	2-3/4	21-5/8	19-3/8	4-1/4	14-3/16	9-5/8	(4)-1	207.8	300	112
SAF 330	7-1/2	26-3/4	7-1/8	3	23-5/8	20-7/8	4-5/8	14-7/8	9-3/4	(4)-1	249.1	320	118
SAF 332	7-7/8	28	7-1/2	3-1/8	24-3/8	21-5/8	4-1/2	15-11/16	10-3/4	(4)-1 1/4	289.6	340	124
SAF 334	8-1/4	29-1/2	8	3-3/8	25	22-1/2	5	16-1/2	11-1/4	(4)-1 1/4	345.3	360	130
SAF 336	8-7/8	31-1/4	8-1/4	3-1/2	26-5/8	24	5-1/4	17-3/4	11-3/8	(4)-1 1/4	369.2	380	136
SAF 338	9-1/2	32-3/4	8-3/4	3-3/4	27-7/8	24-3/4	5-1/4	18-5/8	12	(4)-1 1/2	436.5	400	142
SAF 340	9-7/8	34-1/4	9	4	29-1/2	26-1/4	5-1/2	20	12-1/16	(4)-1 1/2	478.6	420	148

P

NOTES:

- * Basic housing does not include bearing and accessories. The weight is subject to change.
- § For float unit application, order 1-housing, 1-bearing, 1-adapter, and 2-labyrinth seals. For fixed unit application, add 1-stabilizing ring to the above.
- + 4-hole base is also available and must be marked with a prefix F. SAF 522 and SAF 618 and up are standard 4-hole base.

Series SAF 223 Pillow Block Part Numbers

Shaft Diameter		Complete Pillow Block Number	Pillow Block Housing Only	Bearing Number	Locknut	Lockwasher	Labyrinth Seal Ring		Stabilizing Ring / Fixing Ring (1 Req'd.)	End Plug (EPR)
S-2 in.	S-3 in.						S-2 Shaft (1 Req'd.)	S-3 Shaft (1 Req'd.)		
1-15/16	1-7/16	SAF 22308	SAF 308	22308	N 08	W 08	LER 24	LER 17	SR 10-8 90/9.8	3
2-1/8	1-11/16	SAF 22309	SAF 309	22309	N 09	W 09	LER 28	LER 20	SR 11-9 100/9.8	4
2-3/8	1-7/8	SAF 22310	SAF 310	22310	N 10	W 10	LER 35	LER 23	SR 0-10 110/10.8	4
2-9/16	2-1/16	SAF 22311	SAF 311	22311	N 11	W 11	LER 40	LER 27	SR 13-11 120/9.8	6
3-1/16	2-7/16	SAF 22313	SAF 313	22313	N 13	W 13	LER 55	LER 37	SR 16-13 140/9.8	7
3-7/16	2-13/16	SAF 22315	SAF 315	22315	AN 15	W 15	LER 79	LER 46	SR 18-15 160/9.8	8
3-5/8	3	SAF 22316	SAF 316	22316	AN 16	W 16	LER 84	LER 60	SR 19-16 170/9.8	10
3-15/16	3-3/16	SAF 22317	SAF 317	22317	AN 17	W 17	LER 109	LER 188	SR 20-17 180/9.8	11
4-1/8	3-3/8	SAF 22318	SAF 318	22318	AN 18	W 18	LER 112	LER 191	SR 21-18 190/9.8	11
4-1/2	3-13/16	SAF 22320	SAF 320	22320	AN 20	W 20	LER 118	LER 106	SR 24-20 215/9.8	12
4-7/8	4-3/16	SAF 22322	SAF 322	22322	AN 22	W 22	LER 121	LER 113	SR 0-22 240/9.8	14
5-5/16	4-9/16	SAF 22324	SAF 324	22324	AN 24	W 24	LER 127	LER 119	SR 0-24 260/9.8	15
5-7/8	4-15/16	SAF 22326	SAF 326	22326	AN 26	W 26	LER 136	LER 122	SR 0-26 280/9.8	27
6-1/4	5-5/16	SAF 22328	SAF 328	22328	AN 28	W 28	LER 144	LER 127	SR 0-28 300/9.8	16
6-5/8	5-3/4	SAF 22330	SAF 330	22330	AN 30	W 30	LER 151	LER 134	SR 36-30 320/9.8	17
7	6-1/16	SAF 22332	SAF 332	22332	AN 32	W 32	LER 156	LER 142	SR 38-32 340/9.8	18
7-7/16	6-7/16	SAF 22334	SAF 334	22334	AN 34	W 34	LER 161	LER 148	SR 40-34 360/9.8	19
7-13/16	6-7/8	SAF 22336	SAF 336	22336	AN 36	W 36	LER 165	LER 154	SR 0-36 380/9.8	20
8-3/8	7-1/4	SAF 22338	SAF 338	22338	AN 38	W 38	LER 171	LER 160	SR 44-38 400/9.8	21
8-3/4	7-5/8	SAF 22340	SAF 340	22340	AN 40	W 40	LER 175	LER 164	SR 0-40 420/9.8	22



This page left blank intentionally.

Accessories of Rolling Bearings

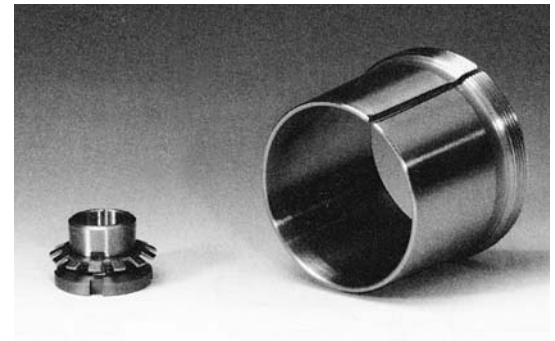

Adapter Sleeves

Adapter sleeves are used for mounting double row self-aligning ball bearings and double row spherical roller bearings with tapered bores on a cylindrical shaft. Boundary dimensions for adapter sleeves comply with standard ISO 113/1.

Withdrawal Sleeves

Withdrawal sleeves are used for mounting tapered-bore double row spherical roller bearings on a cylindrical shaft and to facilitate easy removal for inspection of machine parts and maintenance operations. The taper of a withdrawal sleeve is in the opposite direction of an adapter sleeve. Boundary dimensions of withdrawal sleeves comply with standard ISO 2982.

Locknuts and Lockwashers

Locknuts and lockwashers are used to locate a bearing's inner ring on an adapter sleeve or directly on a tapered shaft. A locknut is also used when dismounting a double row spherical roller bearing that was previously mounted on a withdrawal sleeve. Boundary dimensions for locknuts and lockwashers comply with standard ISO 2982.

Adapter Assemblies

Adapter assemblies consist of the adapter, locknut, and lockwasher. The assemblies are listed in the dimension tables and are noted by nomenclature H, HA, HE, SNW, and SNP. The H assemblies are used on metric shafts. The HE assemblies are used on whole, quarter, or half inch shafts. HA, SNW, and SNP assemblies are used on 16th inch shafts. The difference in the assemblies is HA have metric threads and SNW or SNP have inch threads.

Consult ZVL-ZKL Bearings Corporation before making any substitution of SNW's with HA's or vice versa.

Adapter Assemblies

Shaft Sizes = 20 to 50 mm

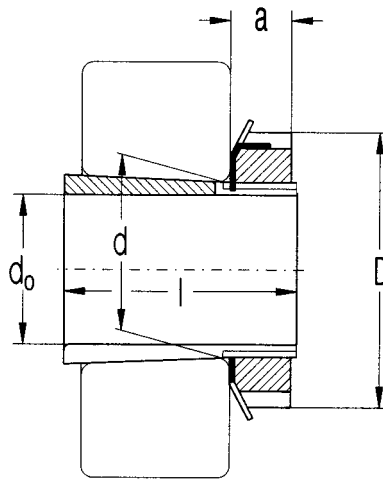

Shaft Size	Dimension				Adapter Designation	Thread	Weight	Components		Adapter Fits the Following Bearings
	d	D	l	a				Nut	Washer	
d_o	mm						kg			
20 mm	25	38	26	8	H205	M25x1.5	0.070	KM5	MB5	1205K
	25	38	29	8	H305	M25x1.5	0.075	KM5	MB5	2205K, 1305K, 22205K
	25	38	35	8	H2305	M25x1.5	0.087	KM5	MB5	2305K
25 mm	30	45	27	8	H206	M30x1.5	0.099	KM6	MB6	1206K
	30	45	31	8	H306	M30x1.5	0.109	KM6	MB6	2206K, 1306K, 22206K
	30	45	38	8	H2306	M30x1.5	0.126	KM6	MB6	2306K
15/16 in	30	45	31	8	HA306	M30x1.5	0.110	KM6	MB6	2206K, 1306K, 22206K
1 in	30	45	38	8	HA2306	M30x1.5	0.130	KM6	MB6	2306K
	30	45	31	8	HE306	M30x1.5	0.110	KM6	MB6	2206K, 1306K, 22206K
	30	45	38	8	HE2306	M30x1.5	0.130	KM6	MB6	2306K
30 mm	35	52	29	9	H207	M35x1.5	0.125	KM7	MB7	1207K
	35	52	35	9	H307	M35x1.5	0.142	KM7	MB7	2207K, 1307K, 22207K
	35	52	43	9	H2307	M35x1.5	0.165	KM7	MB7	2307K
1 3/16 in	35	52	35	9	HA307	M35x1.5	0.140	KM7	MB7	2207K, 1307K, 22207K
1 1/4 in	35	52	43	9	HA2307	M35x1.5	0.170	KM7	MB7	2307K
	35	52	35	9	HE307	M35x1.5	0.140	KM7	MB7	2207K, 1307K, 22207K
	35	52	35	9	HE307	M35x1.5	0.140	KM7	MB7	2207K, 1307K, 22207K
35 mm	40	58	31	10	H208	M40x1.5	0.174	KM8	MB8	1208K
	40	58	36	10	H308	M40x1.5	0.189	KM8	MB8	2208K, 1308K, 22208K
	40	58	46	10	H2308	M40x1.5	0.224	KM8	MB8	2308K, 22308K
40 mm	45	65	33	11	H209	M45x1.5	0.227	KM9	MB9	1209K
	45	65	39	11	H309	M45x1.5	0.248	KM9	MB9	2209K, 1309K, 22209K
	45	65	50	11	H2309	M45x1.5	0.280	KM9	MB9	2309K, 22309K
1 7/16 in	45	65	39	11	HA309	M45x1.5	0.250	KM9	MB9	2209K, 1309K, 22209K
1 1/2 in	45	65	50	11	HA2309	M45x1.5	0.280	KM9	MB9	2309K, 22309K
	45	65	39	11	HE309	M45x1.5	0.250	KM9	MB9	2209K, 1309K, 22209K
	45	65	50	11	HE2309	M45x1.5	0.280	KM9	MB9	2309K, 22309K
45 mm	50	70	35	12	H210	M50x1.5	0.274	KM10	MB10	1210K
	50	70	42	12	H310	M50x1.5	0.303	KM10	MB10	2210K, 1310K, 22210K
	50	70	55	12	H2310	M50x1.5	0.362	KM10	MB10	2310K, 22310K
1 11/16 in	50	70	42	12	HA310	M50x1.5	0.300	KM10	MB10	2210K, 1310K, 22210K
1 3/4 in	50	70	55	12	HA2310	M50x1.5	0.360	KM10	MB10	2310K, 22310K
	50	70	42	12	HE310	M50x1.5	0.300	KM10	MB10	2210K, 1310K, 22210K
	50	70	42	12	HE310	M50x1.5	0.300	KM10	MB10	2210K, 1310K, 22210K
50 mm	55	75	37	12	H211	M55x2	0.308	KM11	MB11	1211K
	55	75	45	12	H311	M55x2	0.345	KM11	MB11	2211K, 1311K, 22211K
	55	75	59	12	H2311	M55x2	0.420	KM11	MB11	2311K, 22311K
1 15/16 in	55	75	45	12	HA311	M55x2	0.350	KM11	MB11	2211K, 1311K, 22211K
2 in	55	75	59	12	HA2311	M55x2	0.420	KM11	MB11	2311K, 22311K
	55	75	45	12	HE311	M55x2	0.350	KM11	MB11	2211K, 1311K, 22211K
	55	75	59	12	HE2311	M55x2	0.420	KM11	MB11	2311K, 22311K

Q

Adapter Assemblies

Shaft Sizes = 55 to 85 mm

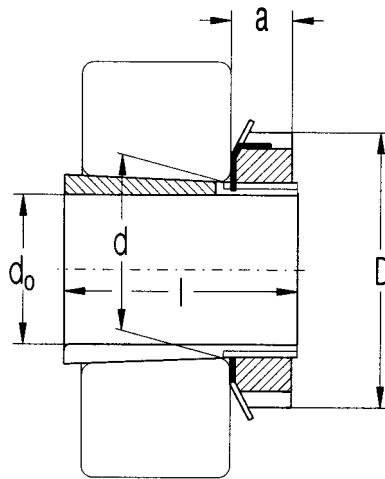

Shaft Size	Dimension				Adapter Designation	Thread	Weight	Components		Adapter Fits the Following Bearings
	d	D	l	a				Nut	Washer	
d_o	mm						kg			
55 mm	60	80	38	13	H212	M60x2	0.346	KM12	MB12	1212K
	60	80	47	13	H312	M60x2	0.394	KM12	MB12	2212K, 1312K, 22212K
	60	80	62	13	H2312	M60x2	0.481	KM12	MB12	2312K, 22312K
60 mm	65	85	40	14	H213	M65x2	0.401	KM13	MB13	1213K
	65	85	50	14	H313	M65x2	0.458	KM13	MB13	2213K, 1313K, 22213K
	65	85	65	14	H2313	M65x2	0.557	KM13	MB13	2313K, 22313K
1 3/16 in	65	85	50	14	HA313	M65x2	0.460	KM13	MB13	2213K, 1313K, 22213K
	65	85	65	14	HA2313	M65x2	0.560	KM13	MB13	2313K, 22313K
2 1/4 in	65	85	50	14	HE313	M65x2	0.460	KM13	MB13	2213K, 1313K, 22213K
65 mm	75	98	43	15	H215	M75x2	0.707	KM15	MB15	1215K
	75	98	55	15	H315	M75x2	0.831	KM15	MB15	2215K, 1315K, 22215K
	75	98	73	15	H2315	M75x2	1.050	KM15	MB15	2315K, 22315K
2 7/16 in	75	98	55	15	HA315	M75x2	0.830	KM15	MB15	2215K, 1315K, 22215K
	75	98	73	15	HA2315	M75x2	1.050	KM15	MB15	2315K, 22315K
2 1/2 in	75	98	55	15	HE315	M75x2	0.830	KM15	MB15	2215K, 1315K, 22215K
	75	98	73	15	HE2315	M75x2	1.050	KM15	MB15	2315K, 22315K
70 mm	80	105	45	17	H216	M80x2	0.882	KM16	MB16	1216K
	80	105	59	17	H316	M80x2	1.030	KM16	MB16	2216K, 1316K, 22216K
	80	105	78	17	H2316	M80x2	1.280	KM16	MB16	2316K, 22316K
2 11/16 in	80	105	59	17	HA316	M80x2	1.030	KM16	MB16	2216K, 1316K, 22216K
	80	105	78	17	HA2316	M80x2	1.280	KM16	MB16	2316K, 22316K
2 3/4 in	80	105	59	17	HE316	M80x2	1.030	KM16	MB16	2216K, 1316K, 22216K
75 mm	85	110	50	18	H217	M85x2	1.020	KM17	MB17	1217K
	85	110	63	18	H317	M85x2	1.180	KM17	MB17	2217K, 1317K, 22217K
	85	110	82	18	H2317	M85x2	1.450	KM17	MB17	2317K, 22317K
2 15/16 in	85	110	63	18	HA317	M85x2	1.180	KM17	MB17	2217K, 1317K, 22217K
	85	110	82	18	HA2317	M85x2	1.450	KM17	MB17	2317K, 22317K
3 in	85	110	63	18	HE317	M85x2	1.180	KM17	MB17	2217K, 1317K, 22217K
	85	110	82	18	HE2317	M85x2	1.450	KM17	MB17	2317K, 22317K
80 mm	90	120	52	18	H218	M90x2	1.19	KM18	MB18	1218K
	90	120	65	18	H318	M90x2	1.37	KM18	MB18	2218K, 1318K, 22218K
	90	120	86	18	H2318	M90x2	1.69	KM18	MB18	2318K, 23218K, 22318K
3 3/16 in	90	120	65	18	HA318	M90x2	1.37	KM18	MB18	2218K, 1318K, 22218K
	90	120	86	18	HA2318	M90x2	1.69	KM18	MB18	2318K, 23218K, 22318K
3 1/4 in	90	120	65	18	HE318	M90x2	1.37	KM18	MB18	2218K, 1318K, 22218K
85 mm	95	125	55	19	H219	M95x2	1.37	KM19	MB19	1219K
	95	125	68	19	H319	M95x2	1.56	KM19	MB19	2219K, 1319K, 22219K
	95	125	90	19	H2319	M95x2	1.92	KM19	MB19	2319K, 22319K

Adapter Assemblies
Shaft Sizes = 90 to 125 mm

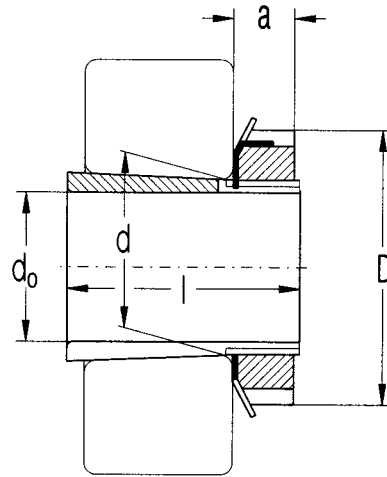

Shaft Size	Dimension				Adapter Designation	Thread	Weight	Components		Adapter Fits the Following Bearings
	d	D	l	a				Nut	Washer	
d _o	mm						kg			
90 mm	100	130	58	20	H220	M100x2	1.49	KM20	MB20	1220K
	100	130	71	20	H320	M100x2	1.69	KM20	MB20	2220K, 1320K, 22220K
3 7/16 in	100	130	97	20	H2320	M100x2	2.15	KM20	MB20	2320K, 23220K, 22320K
	100	130	71	20	HA320	M100x2	1.69	KM20	MB20	2220K, 1320K, 22220K
3 1/2 in	100	130	97	20	HA2320	M100x2	2.15	KM20	MB20	2320K, 23220K, 22320K
	100	130	71	20	HE320	M100x2	1.69	KM20	MB20	2220K, 1320K, 22220K
100 mm	100	130	97	20	HE2320	M100x2	2.15	KM20	MB20	2320K, 23220K, 22320K
	110	145	63	21	H222	M110x2	1.93	KM22	MB22	1222K
3 15/16 in	110	145	77	21	H322	M110x2	2.18	KM22	MB22	1222K, 1322K, 22222K
	110	145	81	21	H3122	M110x2	2.25	KM22	MB22	23122K
4 in	110	145	105	21	H2322	M110x2	2.74	KM22	MB22	2322K, 23222K, 22322K
	110	145	77	21	HA322	M110x2	2.18	KM22	MB22	2222K, 1322K, 22222K
110 mm	110	145	81	21	HA3122	M110x2	2.25	KM22	MB22	23122K
	110	145	105	21	HA2322	M110x2	2.74	KM22	MB22	2322K, 23222K, 22322K
4 3/16 in	110	145	77	21	HE322	M110x2	2.18	KM22	MB22	2222K, 1322K, 22222K
	110	145	105	21	HE2322	M110x2	2.74	KM22	MB22	2322K, 23222K, 22322K
110 mm	120	145	72	22	H3024	M120x2	1.93	KM24	MB24	23024K
	120	155	88	22	H3124	M120x2	2.64	KM24	MB24	23124K
4 3/16 in	120	155	112	22	H2324	M120x2	3.19	KM24	MB24	23224K, 22324K
	120	155	88	22	HA3124	M120x2	2.64	KM24	MB24	23124K
115 mm	120	155	112	22	HA2324	M120x2	3.19	KM24	MB24	23224K, 22324K
	130	155	80	23	H3026	M130x2	2.85	KM26	MB26	23026K
4 7/16 in	130	165	92	23	H3126	M130x2	3.66	KM26	MB26	23126K, 22226K
	130	165	121	23	H2326	M130x2	4.60	KM26	MB26	23226K, 22326K
115 mm	130	155	80	23	HA3026	M130x2	2.85	KML26	MB26	23026K
	130	165	92	23	HA3126	M130x2	3.66	KM26	MB26	23126K, 22226K
125 mm	130	165	121	23	HA2326	M130x2	4.60	KM26	MB26	23226K, 22326K
	140	165	82	24	H3028	M140x2	3.16	KML28	MB28	23028K
4 15/16 in	140	180	97	24	H3128	M140x2	4.34	KM28	MB28	23128K, 22228K
	140	180	131	24	H2328	M140x2	5.55	KM28	MB28	23228K, 22328K
125 mm	140	165	82	24	HA3028	M140x2	3.16	KML28	MB28	23028K
	140	180	97	24	HA3128	M140x2	4.34	KM28	MB28	23128K, 22228K
5 in	140	180	131	24	HA2328	M140x2	5.55	KM28	MB28	23228K, 22328K
	140	165	82	24	HE3028	M140x2	3.16	KML28	MB28	23028K
125 mm	140	180	97	24	HE3128	M140x2	4.34	KM28	MB28	23128K, 22228K
	140	180	131	24	HE2328	M140x2	5.55	KM28	MB28	23228K, 22328K

Adapter Assemblies
Shaft Sizes = 135 to 180 mm

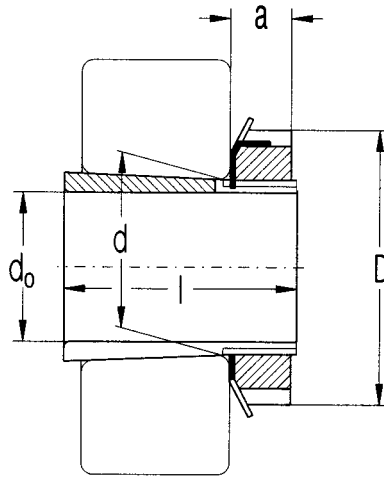

Shaft Size	Dimension				Adapter Designation	Thread	Weight	Components		Adapter Fits the Following Bearings
	d	D	l	a				Nut	Washer	
d _o	mm						kg			
135 mm	150	180	87	26	H3030	M150x2	3.89	KML30	MB30	23030K
	150	195	111	26	H3130	M150x2	5.52	KM30	MB30	23130K, 22230K
	150	195	139	26	H2330	M150x2	6.63	KM30	MB30	23230K, 22330K
	150	180	87	26	HA3030	M150x2	3.89	KML30	MB30	23030K
5 3/16 in	150	195	139	26	HA2330	M150x2	6.63	KM30	MB30	23230K, 22330K
	140 mm	160	190	93	28	H3032	M160x2	5.21	KML32	MB32
5 7/16 in	160	210	119	28	H3132	M160x2	7.67	KM32	MB32	23132K, 22232K
	160	210	147	28	H2332	M160x2	9.14	KM32	MB32	23232K, 22332K
	160	190	93	28	HA3032	M160x3	5.21	KML32	MB32	23032K
	160	210	147	28	HA2332	M160x3	9.14	KM32	MB32	23232K, 22332K
5 1/2 in	160	210	119	28	HE3132	M160x2	7.67	KM32	MB32	23132K, 22232K
150 mm	170	200	101	29	H3034	M170x3	5.99	KML34	MB34	23034K
	170	220	122	29	H3134	M170x3	8.36	KM34	MB34	23134K, 22234K
	170	220	154	29	H2334	M170x3	10.20	KM34	MB34	23234K, 22334K
	170	200	101	29	HA3034	M170x3	5.99	KML34	MB34	23034K
5 15/16 in	170	220	122	29	HA3134	M170x3	8.36	KM34	MB34	23134K, 22234K
	170	220	154	29	HA2334	M170x3	10.20	KM34	MB34	23234K, 22334K
6 in	170	200	101	29	HE3034	M170x3	5.99	KML34	MB34	23034K
	170	220	122	29	HE3134	M170x3	8.36	KM34	MB34	23134K, 22234K
160 mm	180	210	109	30	H3036	M180x3	6.83	KML36	MB36	23036K
	180	230	131	30	H3136	M180x3	9.50	KM36	MB36	23136K, 22236K
	180	230	161	30	H2336	M180x3	11.30	KM36	MB36	23236K, 22336K
	180	210	109	30	HA3036	M180x3	6.83	KML36	MB36	23036K
6 7/16 in	180	230	131	30	HA3136	M180x3	9.50	KM36	MB36	23136K, 22236K
	180	230	161	30	HA2336	M180x3	11.30	KM36	MB36	23236K, 22336K
170 mm	190	220	112	31	H3038	M190x3	7.45	KML38	MB38	23038K
	190	240	141	31	H3138	M190x3	10.80	KM38	MB38	23138K, 22238K
	190	240	169	31	H2338	M190x3	12.60	KM38	MB38	23238K, 22338K
	190	220	112	31	HA3038	M190x3	7.45	KML38	MB38	23038K
6 15/16 in	190	240	169	31	HA2338	M190x3	12.60	KM38	MB38	23238K, 22338K
	180 mm	200	240	120	32	H3040	M200x3	9.19	KML40	MB40
7 3/16 in	200	250	150	32	H3140	M200x3	12.10	KM40	MB40	23140K, 22240K
	200	250	176	32	H2340	M200x3	13.90	KM40	MB40	23240K, 22340K
	200	240	120	32	HA3040	M200x3	9.19	KML40	MB40	23040K
	200	250	176	32	HE2340	M200x3	13.90	KM40	MB40	23240K, 22340K
7 15/16 in	220	260	126	30	HA3044	M220x3	10.50	KML44	MB44	23044K
	220	280	161	35	HA3144	M220x3	15.00	KM44	MB44	23144K, 22244K
	220	280	186	35	HA2344	M220x3	17.00	KM44	MB44	23244K, 22344K



Adapter Assemblies

Shaft Sizes = 1-7/16 in - 5-7/16 in

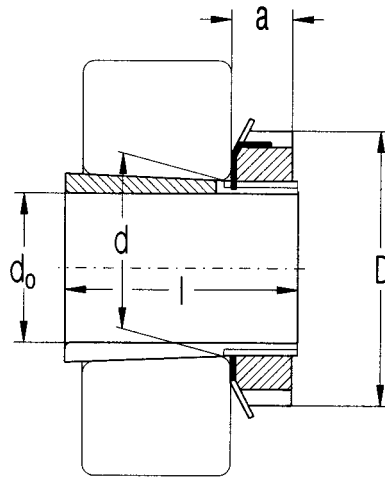

Shaft Size d_o	Dimension				Adapter Designation	Thread	Weight kg	Components		Adapter Fits the Following Bearings
	d	D	l	a				Nut	Washer	
	in.									
1 7/16"	1.772	1.584	0.662	1.7277	SNW 09	18	0.6	N 09	W 09	2209K, 1309K, 22209K 2309K, 22309K
	1.772	2.133	0.662	1.7277	SNW 109	18	0.7	N 09	W 09	
1 11/16"	1.969	1.765	0.724	1.9277	SNW 10	18	0.7	N 10	W 10	2210K, 1310K, 22210, 2310K, 22310K
	1.969	2.394	0.724	1.9277	SNW 110	18	0.8	N 10	W 10	
1 15/16"	2.165	1.845	0.729	2.1174	SNW 11	18	0.8	N 11	W 11	2211K, 1311K, 22211K 22311K, 22311K
	2.165	2.516	0.729	2.1174	SNW 111	18	0.9	N 11	W 11	
2 3/16"	2.559	2.100	0.792	2.5084	SNW 13	18	1.3	N 13	W 13	2213K, 1313K, 22213K 2313K, 22313K
	2.559	2.771	0.792	2.5084	SNW 113	18	1.7	N 13	W 13	
2 7/16"	2.953	2.296	0.895	2.8752	SNW 15	12	2.2	AN 15	W 15	2215K, 1315K, 22215K 2315K, 22315K
	2.953	3.084	0.895	2.8752	SNW 115	12	2.9	AN 15	W 15	
2 11/16"	3.150	2.376	0.895	3.0790	SNW 16	12	2.4	AN 16	W 16	2216K, 1316K, 22216K 2316K, 22316K
	3.150	3.204	0.895	3.0790	SNW 116	12	3.1	AN 16	W 16	
2 15/16"	3.346	2.486	0.926	3.2812	SNW 17	12	2.9	AN 17	W 17	2217K, 1317K, 22217K 2317K, 22317K
	3.346	3.312	0.926	3.2812	SNW 117	12	3.4	AN 17	W 17	
3 3/16"	3.543	2.646	1.010	3.4682	SNW 18	12	3.0	AN 18	W 18	2218K, 1318K, 22218K 2318K, 23218K, 22318K
	3.543	3.553	1.010	3.4682	SNW 118	12	3.9	AN 18	W 18	
3 7/16"	3.937	2.869	1.073	3.8592	SNW 20	12	4.3	AN 20	W 20	2220K, 1320K, 22220K 23220K, 22320K
	3.937	3.971	1.073	3.8592	SNW 120	12	6.2	AN 20	W 20	
3 15/16"	4.331	3.206	1.135	4.2648	SNW 22	12	5.0	AN 22	W 22	2222K, 1322K, 22222K 23222K, 22322K
	4.331	4.348	1.135	4.2648	SNW 122	12	6.4	AN 22	W 22	
4 3/16"	4.724	3.466	1.166	4.6558	SNW 24	12	6.6	AN 24	W 24	2224K 22324K
	4.724	4.648	1.166	4.6558	SNW 124	12	7.8	AN 24	W 24	
4 7/16"	5.118	3.762	1.229	5.0458	SNW 26	12	9.7	AN 26	W 26	2226K 22326K
	5.118	4.982	1.229	5.0458	SNW 126	12	12.4	AN 26	W 26	
4 15/16"	5.512	3.981	1.291	5.4368	SNW 28	12	10.3	AN 28	W 28	2228K 22328K
	5.512	5.323	1.291	5.4368	SNW 128	12	13.0	AN 28	W 28	
5 3/16"	5.906	4.241	1.354	5.8278	SNW 30	12	15.8	AN 30	W 30	2230K 22330K
	5.906	5.621	1.354	5.8278	SNW 130	12	18.0	AN 30	W 30	
5 7/16"	6.299	4.578	1.510	6.1953	SNW 32	8	15.6	AN 32	W 32	2232K 22332K
	6.299	5.920	1.510	6.1953	SNW 132	8	18.1	AN 32	W 32	
	6.299	3.711	1.468	6.1953	SNW 3032	8	11.8	N 032	W 032	23032K

Q

Adapter Assemblies

Shaft Sizes = 5-15/16 in - 13-15/16 in

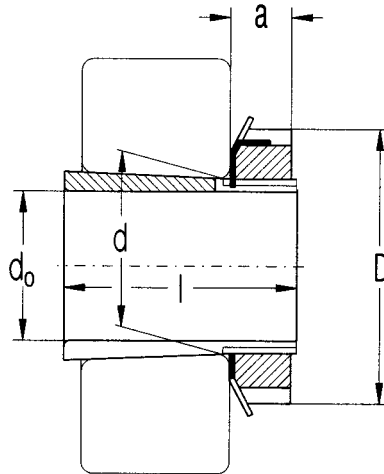

Shaft Size	Dimension				Adapter Designation	Thread	Weight	Components		Adapter Fits the Following Bearings
	d	D	l	a				Nut	Washer	
d _o	in.						kg			
5 15/16"	6.693	4.847	1.541	6.5703	SNW 34	8	19.4	AN 34	W 34	22234K
	6.693	6.188	1.541	6.5703	SNW 134	8	21.0	AN 34	W 34	22334K
	6.693	4.019	1.500	6.5703	SNW 3034	8	13.3	N 034	W 034	23034K
6 7/16"	7.087	5.038	1.573	6.9773	SNW 36	8	20.5	AN 36	W 36	22236K
	7.087	6.456	1.573	6.9773	SNW 136	8	22.4	AN 36	W 36	22336K
	7.087	4.337	1.531	6.9773	SNW 3036	8	15.2	N 036	W 036	23036K
6 15/16"	7.480	5.261	1.604	7.3833	SNW 38	8	23.4	AN 38	W 38	22238K
	7.480	6.758	1.604	7.3833	SNW 138	8	28.1	AN 38	W 38	22338K
	7.480	4.412	1.594	7.3833	SNW 3038	8	16.7	N 038	W 038	23038K
7 3/16"	7.874	5.484	1.666	7.7521	SNW 40	8	30.7	AN 40	W 40	22240K
	7.874	7.095	1.666	7.7521	SNW 140	8	35.7	AN 40	W 40	22340K
	7.874	4.750	1.656	7.7521	SNW 3040	8	19.7	N 040	W 040	23040K
7 15/16"	8.661	5.901	1.698	8.5378	SNW 44	8	32.3	N 44	W 44	22244K
	8.661	5.130	1.750	8.5378	SNW 3044	8	24.4	N 044	W 044	23044K
8 15/16"	9.449	5.432	1.968	9.3245	SNP 3048	6	32.2	N 048	P 48	23048K
9 7/16"	10.236	6.019	2.125	10.0742	SNP 3052	6	41.1	N 052	P 52	23052K
10 7/16"	11.024	6.191	2.219	10.8852	SNP 3056	6	45.4	N 056	P 56	23056K
10 15/16"	11.811	6.727	2.281	11.6662	SNP 3060	6	58.9	N 060	P 60	23060K
11 15/16"	12.598	6.946	2.375	12.4439	SNP 3064	6	65.7	N 064	P 64	23064K
12 7/16"	13.386	7.543	2.531	13.1910	SNP 3068	5	77.8	N 068	P 68	23068K
13 7/16"	14.173	7.579	2.531	14.0220	SNP 3072	5	86.2	N 072	P 72	23072K
13 15/16"	14.961	7.743	2.656	14.8090	SNP 3076	5	94.3	N 076	P 76	23076K

Withdrawal Sleeves

$d_0 = 35$ to 105 mm

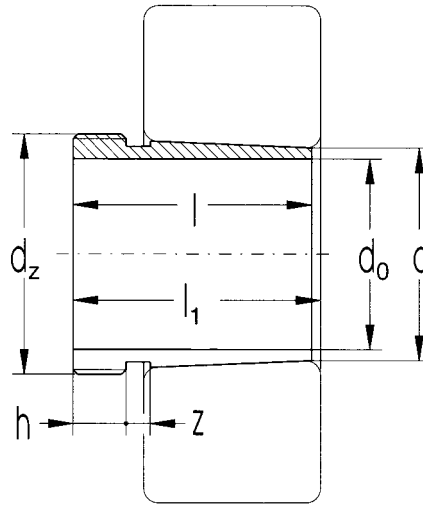

Dimension							Sleeve Designation	Corresp. Withdrawal Nut	Weight
d_0	d	d_z	l	l_1	h	z			
mm									kg
35	40	M45x1.5	30	32	6	5.000	AH308	KM9	0.093
	40	M45x1.5	40	43	7	6.000	AH2308	KM9	0.129
40	45	M50x1.5	32	34	6	6.000	AH309	KM10	0.112
	45	M50x1.5	44	47	7	6.000	AH2309	KM10	0.163
45	50	M55x2	35	38	7	6.000	AH310X	KM11	0.138
	50	M55x2	50	53	8	6.000	AH2310X	KM11	0.236
50	55	M60x2	40	43	8	7.000	AH312X	KM13	0.194
	55	M60x2	54	57	9	6.000	AH2311X	KM12	0.257
55	60	M65x2	40	43	8	7.000	AH312X	KM13	0.194
	60	M65x2	57	61	10	7.000	AH2312X	KM13	0.299
60	65	M72x2	42	45	8	7.000	AH313	KM15	0.256
	65	M75x2	61	64	11	7.000	AH2313	KM15	0.399
65	70	M80x2	44	47	8	7.000	AH314	KM16	0.290
	70	M80x2	65	68	12	7.000	AH2314X	KM16	0.466
70	75	M85x2	46	49	8	7.000	AH315	KM17	0.326
	75	M85x2	69	72	12	7.000	AH2315X	KM17	0.536
75	80	M90x2	48	52	8	7.000	AH316	KM18	0.367
	80	M90x2	72	75	12	7.000	AH2316X	KM18	0.602
80	85	M95x2	52	56	9	7.000	AH317X	KM19	0.431
	85	M95x2	75	78	13	7.000	AH2317X	KM19	0.676
85	90	M100x2	53	57	9	7.000	AH318X	KM20	0.465
	90	M100x2	63	67	10	7.000	AH2318X	KM20	0.578
	90	M100x2	80	83	14	7.000	AH2318X	KM20	0.777
90	95	M105x2	57	61	10	8.000	AH319X	KM21	0.537
	95	M105x2	85	89	15	8.000	AH2319X	KM21	0.888
95	100	M110x2	59	63	10	8.000	AH302X	KM22	0.586
	100	M110x2	75	77	12	7.000	AH3220X	KM22	0.768
	100	M110x2	90	94	15	8.000	AH2320X	KM22	1.000
100	110	M125x2	68	72	11	8.000	AH3122	KM25	1.280
105	110	M120x2	68	72	11	8.000	AH3122X	KM24	0.786
	110	M125x2	82	86	12	8.000	AH3222X	KM25	1.060
	110	M125x2	98	102	16	8.000	AH2322X	KM25	1.350

Withdrawal Sleeves

$d_0 = 110$ to 180 mm

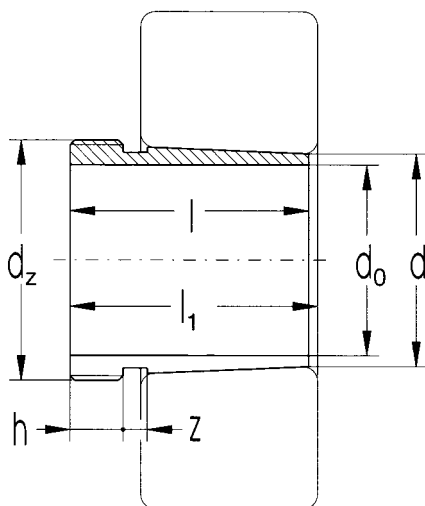

Dimension							Sleeve Designation	Corresp. Withdrawal Nut	Weight
d_0	d	d_z	l	l_1	h	z			
mm									kg
110	120	M140x2	75	79	12	8	AH3124	KM28	1.670
	120	M140x2	105	109	17	8	AH2324	KM28	2.470
115	120	M130x2	60	64	13	8	AH3024X	KM26	0.737
	120	M130x2	75	79	12	8	AH3124X	KM26	0.948
	120	M135x2	90	94	14	8	AH3224X	KM27	1.310
	120	M135x2	105	109	17	8	AH2324X	KM27	1.610
125	130	M140x2	67	71	14	8	AH3026X	KM28	0.907
	130	M140x2	78	82	12	8	AH3126X	KM28	1.080
	130	M145x2	98	102	15	8	AH3236X	KM29	1.580
	130	M145x2	115	119	19	8	AH2326X	KM29	1.970
135	140	M150x2	68	73	14	10	AH3028X	KM30	0.996
	140	M150x2	83	88	14	10	AH3128X	KM30	1.260
	140	M155x3	104	109	15	10	AH3228X	KM31	1.810
	140	M155x3	125	130	20	10	AH2328X	KM31	2.340
145	150	M160x3	72	77	15	10	AH3030X	KM32	1.120
	150	M165x3	96	101	15	10	AH3130X	KM33	1.750
	150	M165x3	114	119	18	10	AH3230X	KM33	2.210
	150	M165x3	135	140	24	10	AH2330X	KM33	2.790
150	160	M170x3	77	82	16	10	AH3032	KM34	2.010
	160	M180x3	103	108	16	10	AH3132	KM36	3.180
	160	M180x3	124	130	20	12	AH3232	KM36	4.020
	160	M180x3	140	146	24	12	AH2332	KM36	4.690
160	170	M180x3	85	90	17	10	AH3034	KM36	2.400
	170	M190x3	104	109	16	10	AH3134	KM38	3.410
	170	M190x3	134	140	24	12	AH3234	KM38	3.410
	170	M190x3	146	152	24	12	AH2334	KM38	5.230
170	180	M190x3	92	98	17	12	AH3036	KM38	2.800
	180	M200x3	116	122	19	12	AH3136	KM40	4.160
	180	M200x3	105	110	17	10	AH2236	KM40	3.670
	180	M200x3	140	146	24	12	AH3236X	KM40	5.290
	180	M200x3	154	160	26	12	AH2336	KM40	5.940
180	190	Tr205x4	96	102	17	12	AH3038	HML41T	3.280
	190	Tr210x4	125	131	19	12	AH3138	HM42T	7.730
	190	Tr210x4	112	117	18	10	AH2238	HM42T	4.150
	190	Tr210x4	160	167	26	14	AH2338	HM42T	6.530
	190	Tr210x4	145	152	25	14	AH3238	HM42T	5.800



Locknuts

d = M25 x 1.5 to M200 x 3

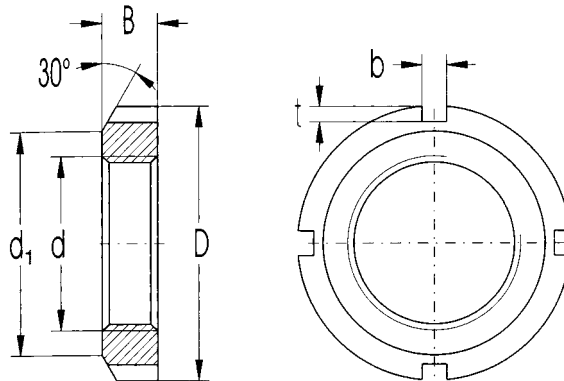

Dimension						Locknut Designation	Corresp. Lockwasher	Weight
d	D	d ₁	B	b	t			
mm								kg
M25x1.5	38	32	7	5	2.000	KM5	MB5	0.025
M30x1.5	45	38	7	5	2.000	KM6	MB6	0.043
M35x1.5	52	44	8	5	2.000	KM7	MB7	0.053
M40x1.5	58	50	9	6	2.500	KM8	MB8	0.085
M45x1.5	65	56	10	6	2.500	KM9	MB9	0.120
M50x1.5	70	61	11	6	2.500	KM10	MB10	0.150
M55x2	75	67	11	7	3.000	KM11	MB11	0.160
M60x2	80	73	11	7	3.000	KM12	MB12	0.170
M65x2	85	79	12	7	3.000	KM13	MB13	0.200
M70x2	92	85	12	8	3.500	KM14	MB14	0.240
M75x2	98	90	13	8	3.500	KM15	MB15	0.290
M80x2	105	95	15	8	3.500	KM16	MB16	0.400
M85x2	110	102	16	8	3.500	KM17	MB17	0.450
M90x2	120	108	16	10	4.000	KM18	MB18	0.560
M95x2	125	113	17	10	4.000	KM19	MB19	0.660
M100x2	130	120	18	10	4.000	KM20	MB20	0.700
M105x2	140	126	18	12	5.000	KM21	MB21	0.840
M110x2	145	133	19	12	5.000	KM22	MB22	0.970
M115x2	150	137	19	12	5.000	KM23	MB23	1.010
M120x2	155	138	20	12	5.000	KM24	MB24	1.080
M125x2	160	148	21	12	5.000	KM25	MB25	1.190
M130x2	165	149	21	12	6.000	KM26	MB26	1.250
M140x2	180	160	22	14	6.000	KM28	MB28	1.600
M150x2	195	171	24	14	6.000	KM30	MB30	2.030
M160x3	210	182	25	16	7.000	KM32	MB32	2.590
M170x3	220	193	26	16	7.000	KM34	MB34	2.800
M180x3	230	203	27	18	8.000	KM36	MB36	3.070
M190x3	240	214	28	18	8.000	KM38	MB38	3.390
M200x3	250	226	29	18	8.000	KM40	MB40	3.690

Q

Lockwashers
 $d_1 = 15$ to 200 mm

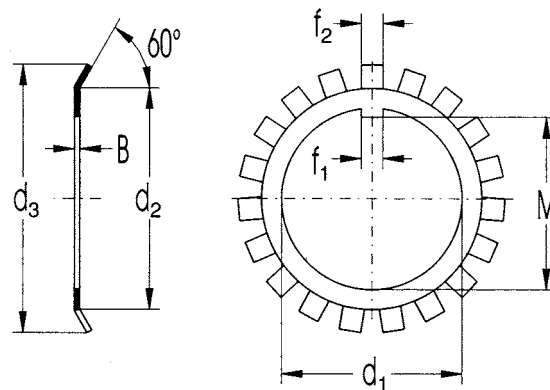

Dimension							Lockwasher Designation	Weight 100 pcs kg
d_1	d_2	d_3	B	f_1	f_2	M		
mm								
15	21	28	1	4	4	13.5	MB2	0.26
17	24	32	1	4	4	15.5	MB3	0.32
20	26	36	1	4	4	18.5	MB4	0.35
25	32	42	1.25	5	5	23.0	MB5	0.64
30	28	49	1.25	5	5	27.5	MB6	0.78
35	44	57	1.25	6	5	32.5	MB7	1.04
40	50	62	1.25	6	6	37.5	MB8	1.23
45	56	69	1.25	6	6	42.5	MB9	1.52
50	61	74	1.25	6	6	47.5	MB10	1.60
55	67	81	1.5	8	7	52.5	MB11	1.96
60	73	86	1.5	8	7	57.5	MB12	2.53
65	79	92	1.5	8	7	62.2	MB13	2.90
70	85	98	1.5	8	8	66.5	MB14	3.34
75	90	104	1.5	8	8	71.5	MB15	3.56
80	95	112	1.8	10	8	76.5	MB16	4.64
85	102	119	1.8	10	8	81.5	MB17	5.24
90	108	126	1.8	10	10	86.5	MB18	6.23
95	113	133	1.8	10	10	91.5	MB19	6.70
100	120	140	1.8	12	10	96.5	MB20	7.65
105	126	145	1.8	12	12	100.5	MB21	8.26
110	133	154	1.8	12	12	105.5	MB22	9.40
115	137	159	2	12	12	110.5	MB23	10.80
120	138	164	2	14	12	115.0	MB24	10.50
125	148	170	2	14	12	120.0	MB25	11.80
130	149	175	2	14	12	125.0	MB26	11.30
135	160	185	2	14	14	130.0	MB27	14.40
140	160	192	2	16	14	135.0	MB28	14.20
150	171	205	2	16	14	145.0	MB30	15.50
160	182	217	2.5	18	16	154.0	MB32	22.20
170	193	232	2.5	18	16	164.0	MB34	24.70
180	203	242	2.5	20	18	174.0	MB36	16.80
190	214	252	2.5	20	18	184.0	MB38	27.80
200	226	262	2.5	20	18	194.0	MB40	29.30

Q

Rolling Elements



Balls

Balls are produced from the same material from which the bearing's inner and outer rings are produced. The balls are heat treated to a hardness of 61 to 65 HRC. Balls are produced in tolerance classes 10, 16, 20, 28, 40, and 100 depending on the size of the ball. These tolerance classes comply with standard ISO 3290. Values for these tolerances are listed in the table below.

Limiting Deviation Diameter and Form. Limiting Surface Roughness.							
Tolerance Class	D_w		Δ_{Dwm}	V_{DwL} max	V_{Dws} max	Δ max	R_a max
	over	to					
		mm		μm			
3	0.25	12	± 5	0.13	0.08	0.08	0.012
5	0.25	12	± 5	0.25	0.13	0.13	0.020
10	0.25	25	± 9	0.5	0.25	0.25	0.025
16	0.25	25	± 10	0.8	0.4	0.4	0.032
20	0.25	38	± 10	1	0.5	0.5	0.040
28	0.25	38	± 12	1.4	0.7	0.7	0.050
40	0.25	50	± 16	2	1	1	0.080
100	0.25	120	± 40	5	2.5	2.5	0.125
200	0.25	150	± 60	10	5	5	0.200

- D_w - nominal ball diameter
- Δ_{Dwm} - limiting deviation of mean ball diameter as individual component
- V_{DwL} - ball diameter variation in a lot
- V_{Dws} - individual ball diameter variation
- Δ - deviation from roundness / out-of-roundness
- R_a - surface roughness

Cylindrical Rollers

Cylindrical rollers are also produced from the same material as the inner and outer rings of the bearings and are heat treated to a hardness of 60 to 65 HRC. Cylindrical rollers are produced in several designs. They are produced as a complete cylinder with rounded corners (Z), as a cylinder with crowned edges (ZB), or as a spherical roller or barrel-shaped (ZB). Cylindrical rollers are usually produced in tolerance class III in compliance with standard DIN 5402. Cylindrical rollers produced to a different tolerance class may be available upon request. Values for these tolerances can be found in the charts on the next page.

Limiting Coordinates of Cylindrical Roller Rounding		
Nominal Diameter	Limiting Dimensions of Rounding Coordinates	
r	r _{s min}	r _{s max}
mm	mm	
0.3	0.2	0.5
0.5	0.3	0.8
0.8	0.5	1.2
1	0.7	1.5
1.5	1.1	2.1
2	1.5	2.7

Limiting Deviations of Dimensions, Form and Position. Limiting Surface Roughness.									
Tolerance Class	D _w		Δ _{Dwmp}	V _{DwL}	V _{Dwp}	Δ	V _{Dwmp}	Face Convexity	R _a
	over	to							
	mm		μm						
I.	-	18	+10.25/-16.25	0.5	0.25	0.3	0.3	2	0.08
	18	26	+10.25/-16.25	0.5	0.25	0.4	0.5	2	0.08
II.	-	18	+10.25/-16.25	1	0.5	0.5	0.5	2	0.16
	18	26	+10.25/-16.25	1	0.5	0.8	1	2	0.16
III.	-	18	+11/-17	2	1	1	1	2	0.16
	18	26	+11/-17	2	1	1.5	1	2	0.16
IV.	-	18	0/-45	3	2	2	2	3	0.32
	18	26	0/-45	3	2	3	2	3	0.32

- D_w - short cylindrical roller nominal diameter
Δ_{Dwmp} - limiting deviation of cylindrical roller diameter as individual component
V_{DwL} - variations of cylindrical roller diameter in a lot
V_{Dwp} - variation of individual cylindrical roller diameter
Δ - roundness deviation
V_{Dwmp} - conicity
R_a - cylindrical surface roughness

Dimension and Shape Deviations, except Conicity and Convexity are Valid in Central Section of Cylindrical Rollers.							
Tolerance Class	L _w		Δ _{Lws}	V _{LwL}	S _w	Face Convexity	R _a
	over	to					
	mm		μm				
I.	-	15	+2/-7	3	3	2	0.08
	15	26	+2/-7	3	3	2	0.08
	26	40	+2.5/-7.5	5	5	3	0.08
II.	-	15	+3/-15	6	6	3	0.16
	15	40	+3/-15	6	6	5	0.16
III.	-	26	+10/-20	6	6	3	0.16
	26	40	+10/-20	6	6	5	0.32
IV.	-	10	0/-32	10	16	3	0.63
	10	18	0/-32	10	20	3	0.63
	18	30	0/-32	15	25	5	0.63
	30	40	0/-50	20	30	5	0.63

- L_w - short cylindrical roller nominal length
Δ_{Lws} - limiting length deviations of rollers as individual components
V_{LwL} - roller length variation in a lot
S_w - lateral run-out
R_a - face surface roughness

R

Balls

$D_w = 3.175$ to 45.00

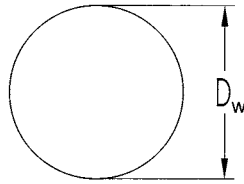

Nominal Diameter		Weight 1000 pcs
D_w		
mm	inch	kg
3.175	1/8	0.132
3.969	5/32	0.257
4.762	3/16	0.444
5.000		0.514
5.556	7/32	0.705
5.953	15/64	0.867
6.000		0.887
6.350	1/4	1.050
6.747	17/64	1.260
7.144	9/32	1.500
7.938	5/16	2.060
8.500		2.520
8.731	11/32	2.730
9.525	3/8	3.550
10.000		4.110
10.319	13/32	4.510
10.500		4.723
11.112	7/16	5.640
11.450		6.160
11.906	15/32	6.930
12.700	1/2	8.420
13.494	17/32	10.100
14.000		11.300
14.288	9/16	12.000
15.081	19/32	14.100

Nominal Diameter		Weight 1000 pcs
D_w		
mm	inch	kg
15.875	5/8	16.400
16.000		16.800
16.669	21/32	19.000
17.462	11/16	21.900
18.256	23/32	25.000
19.050	3/4	28.400
19.844	25/32	32.100
20.000		32.900
20.638	13/16	36.100
21.431	27/31	40.400
22.000		43.800
22.225	7/8	45.100
23.019	29/32	50.100
23.812	15/16	55.500
24.606	31/32	61.200
25.400	1	67.300
26.988	1-1/16	80.800
28.575	1-1/8	95.800
30.162	1-3/16	113.000
31.750	1-1/4	132.000
33.338	1-5/16	152.000
35.000		176.000
40.000		263.000
45.000		374.000

Cylindrical Rollers

$D_w = 5$ to 48 mm

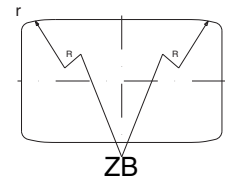
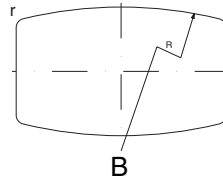
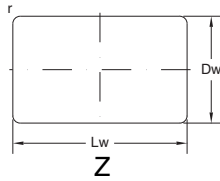

Dimensions		Weight
$D_w \times L_w$	r	1000 pcs
mm		kg
5x10	0.3	1.52
6x8	0.3	1.78
6x12	0.3	2.61
6.350x12	0.6	2.98
6.5x6.5	0.5	1.66
6.5x9	0.5	2.30
7x10	0.5	2.96
7x14	0.5	4.02
7.350x14	0.3	4.66
7.5x7.5	0.5	2.54
7.5x9	0.5	3.06
7.5x11	0.5	3.74
7.5x17	0.4	5.83
7.5x19	0.4	6.52
8x8	0.5	3.08
8x12	0.5	4.65
8x16	0.5	6.27
9x9	0.5	4.40
9x10	0.5	4.96
9x13	0.5	4.54
9x14	0.5	6.80
10x10	0.5	6.00
10x11	0.5	6.70
10x14	0.5	8.50
10x15	0.5	9.20
10x16	0.5	9.80
10x20	0.5	12.25
10x25	0.5	15.30
11x11	0.8	8.10
11x12	0.8	8.90
11x15	0.8	11.08
11x22	0.8	16.20
12x12	0.8	10.40
12x14	0.8	10.40
12x18	0.8	10.40
13x13	0.8	13.30
13x20	0.8	20.40
14x13.8	0.8	16.40
14x14	0.8	16.60
14x15	0.8	18.00

Dimensions		Weight
$D_w \times L_w$	r	1000 pcs
mm		kg
14x20	0.8	23.80
14x22	0.8	26.20
14x26	0.8	31.00
14x28	0.8	33.40
15x15	0.8	20.40
15x16	0.8	22.00
15x17	0.8	23.40
15x22	0.8	30.00
15x24	0.8	32.80
15x25	0.8	34.40
15x30	0.8	41.30
15x32	0.8	43.90
16x16	0.8	24.80
16x17	0.8	26.40
16x24	0.8	37.30
16x27	0.8	42.00
17x17	1	29.70
17x24	1	42.00
17x34	1	59.00
18x18	1	35.70
18x19	1	37.70
18x26	1	51.00
18x30	1	59.60
18x36	1	71.50
19x19	1	41.60
19x20	1	44.40
19x28	1	61.00
19x32	1	70.30
20x20	1	48.50
20x30	1	73.00
20x40	1	97.70
21x21	1	56.00
21x22	1	59.00
21x42	1	112.00
22x22	1	64.00
22x24	1	71.10
22x34	1	100.00
22x44	1	129.00
23x23	1	74.00
23x34	1	112.00

Dimensions		Weight
$D_w \times L_w$	r	1000 pcs
mm		kg
24x24	1	84.00
24x26	1	91.00
24x36	1	126.00
24x40	1	141.00
25x25	1.5	95.00
25x36	1.5	137.00
26x26	1.5	107.00
26x40	1.5	164.00
26x48	1.5	198.00
27x48	1.5	214.00
28x28	1.5	133.00
28x30	1.5	143.00
28x32	1.5	153.00
28x44	1.5	210.00
28x56	1.5	269.00
30x30	1.5	163.00
30x33	1.5	180.00
30x48	1.5	262.00
30x63	1.5	346.00
32x32	1.5	199.00
32x52	1.5	324.00
32x64	1.5	400.00
34x43	2	239.00
34x55	2	387.00
38x38	2	283.00
38x62	2	552.00
40x40	2	389.00
42x42	2	457.00
45x45	2	562.00
48x48	2	682.00

R

General Index

	Page #
Table of Contents	1
Warranty	2
Bearing Designation	3-4
Bearing Nomenclature	5-9
Single Row Deep Groove Ball Bearing Series	10-42
600	14-15, 22-23
16000	14-21
6000	14-25
6200	14-25
6300	14-25
6400	16-19
E, BO	26-27
R	28-29
PLC (Specials)	30-41
Single Row Angular Contact Ball Bearing Series	43-59
7200	50-53
7300	50-53
A, B	54-57
PLC (Specials)	58-59
Double Row Angular Contact Ball Bearing Series	60-65
3200, 3300	62-63
PLC (Specials)	64-65
Double Row Self-Aligning Ball Bearing Series	66-74
1200, 1200K	68-71
1300, 1300K	68-71
2200, 2200K	68-71
2300, 2300K	68-71
PLC (Specials)	72-73
Single Row Cylindrical Roller Bearing Series	75-99
200 - N, NU, NJ, NUJ, NH, NUP, NFD	80-91
300 - N, NU, NJ, NUJ, NH, NUP, NFD	80-91
400 - N, NU, NJ, NUJ, NH, NUP, NFD	80-91
1000 - N, NU, NJ, NUJ, NH, NUP, NFD	80-91
2200 - N, NU, NJ, NUJ, NH, NUP, NFD	80-91
2300 - N, NU, NJ, NUJ, NH, NUP, NFD	80-91
5200 - N, NU, NJ, NUJ, NH, NUP, NFD	80-91
Specials - N/NJP, NU, NJ, NUP, NH, NUB	92-93
PLC (Specials)	94-97
VL (Specials)	98-99
Double Row Cylindrical Roller Bearing Series	100-105
NNU/NN	102-103
PLC (Specials)	104

Double Row Spherical Roller Bearing Series	106-128
222	110-117
223	110-117
230	112-119
231	112-119
232	110-119
239	116-119
240	114-119
241	114-115
PLC (Specials)	120
223 - Shaker Screens / Vibratory Equipment	121-123
PLC - Mobile Cement Mixer Gearboxes	125-127
Spherical Plain Bearing Series	129-132
GE	130-131
GEW	130-131
Tapered Roller Bearing Series	133-149
30200 (Metric)	136-141
30300 (Metric)	136-139
31300 (Metric)	136-141
32000 (Metric)	136-141
32200 (Metric)	136-141
32300 (Metric)	136-139
32900 (Metric)	140-141
33000 (Metric)	140-141
33100 (Metric)	140-141
33200 (Metric)	140-141
K (Inch)	142-145
36000 (Metric - Four Row)	146-147
PLC (Specials)	148-149
Thrust Ball Bearing Series	150-161
51100 Single Direction	152-157
51200 Single Direction	152-157
51300 Single Direction	152-155
51400 Single Direction	152-155
PLC (Specials) Single Direction	158-159
52200 Double Direction	160-161
52300 Double Direction	160-161
52400 Double Direction	160-161
Spherical Roller Thrust Bearing Series	162-170
29200	166-169
29300	164-169
29400	164-169
Insert Ball Bearings and Insert Ball Bearing Units	171-184
200 UA, UC, UD, UE, US - Insert Ball Bearing	172-173
200 SGA, SGC - Pillow Block Units	174-175
200 FGA, FGC - Square Flanged Units	176-177
200 FMA, FMC - Oval Flanged Units	178-179
200 FBA, FBC - Triangle Pressed Flanged Units	180-181
200 SAD, SAE, SAS - Sheet Pillow Block Units	182-183



