



High-precision bearings



SPINDEL- UND LAGERUNGSTECHNIK
FRAUREUTH GMBH



1.	Spindle bearings and high-speed spindle bearings	6
1.1.	General	
1.1.1.	Spindle bearings	
1.1.2.	High-speed spindle bearings	
1.2.	Tolerances and standards	
1.3.	Designs	
1.4.	Materials	
1.4.1.	Outer and inner rings, balls	
1.4.2.	Cage	
1.5.	Contact angle	
2.	Bearing data	10
2.1.	Tolerances and tolerance classes	
2.2.	Dimension groups for spindle bearings	
2.3.	Rotational speeds	
2.4.	Operating temperature	
2.5.	Noise	
3.	Universal bearings, bearing sets	17
3.1.	Universal bearings „U“	
3.2.	Bearing arrangements	
3.2.1.	O-arrangement	
3.2.2.	X-arrangement	
3.2.3.	Tandem-arrangement	
3.2.4.	Multiple arrangement	
3.2.4.1.	TO- and TX-arrangement	
3.2.4.2.	TOT- and TXT-arrangement	
3.3.	Spacer rings	
4.	Hybrid spindle bearings	20

5.	Sealed spindle bearings	21
6.	Spindle bearing with direct lubrication	22
7.	Bearing design calculation	23
7.1.	General	
7.2.	Nominal rating life	
7.3.	Equivalent dynamic loading	
7.4.	Calculation of speed limit	
7.5.	Suspension and stiffness	
7.6.	Load-bearing capacity	
7.7.	Preloading	
8.	Installation tolerances of spindle bearings	27
8.1.	Machining tolerances of the parts surrounding the bearings	
8.2.	Guidelines for machining of shafts	
8.3.	Guidelines for machining of housing bores	
9.	Installation	29
9.1.	Preparation of installation	
9.2.	Greasing of bearings	
9.3.	Bearing installation	
9.3.1.	Installation with press	
9.3.2.	Installation with high bearing temperature	
9.4.	Bearing securing	
9.4.1.	Fastening with precision nuts	
9.4.2.	Fastening with housing cover	
10.	Bearing labelling	32
10.1.	Content and location of label	
10.2.	Labelling schema for spindle bearings	
11.	Converting other makes to SLF product designation	34

12.	Measurement tables	36
12.1.	Spindle bearing	from 36
12.2.	High-speed spindle bearing	from 74
13.	High-precision cylindrical roller bearings	100
13.1.	General	
13.2.	Heat treatment	
13.3.	Designs	
13.4.	Hybrid cylindrical roller bearings	
13.5.	Materials	
14.	Tolerances and tolerance classes	104
15.	Bearing clearance	106
16.	Bearing design calculation	107
16.1.	General	
16.2.	Nominal rating life	
16.3.	Equivalent dynamic loading	
17.	Installation tolerances for cylindrical roller bearings	108
17.1.	Machining tolerances of the parts surrounding the bearings	
17.2.	Guidelines for machining of cylindrical shafts	
17.3.	Guidelines for machining of tapered shafts	
17.4.	Guidelines for machining of housing bores	
18.	Installation	112
18.1.	Preparation of installation	
18.2.	Greasing of bearings	
18.3.	Bearing installation	
19.	Bearing labelling	114
19.1.	Content and location of label	
19.2.	Labelling schema for high-precision cylindrical roller bearings	

20.	Converting other makes to SLF product designation	115
21.	Measurement tables	116
21.1.	High-precision cylindrical roller bearings, single-row	from 116
21.2.	High-precision cylindrical roller bearings, double-row	from 122
22.	Terms and symbols according to DIN ISO 1132-1, DIN 620	126
22.1.	Bore diameter	
22.2.	Shell diameter	
22.3.	Width	
22.4.	Corner radius	
22.5.	Variation in wall thickness	
22.6.	Running accuracy	
22.6.1.	Radial run-out	
22.6.2.	Axial run-out	
22.6.3.	Lateral run-out	
23.	Lubrication	129
23.1.	General	
23.2.	Grease lubrication	
23.2.1.	Grease service life	
23.2.2.	Running-in of grease	
23.2.3.	Amount of grease	
23.3.	Oil lubrication	
24.	Terms of delivery	134

SLF-high-precision bearings



SLF-high-precision bearings are manufactured in single and double-row design as spindle bearings, high-speed spindle bearings and high precision cylindrical roller bearings.

1.1. General

Spindle bearings are a special design of single-row angular contact ball bearings. They are specifically implemented in the machine tool industry as well as in other areas of application, where the bearings are subject to high to extremely stringent requirements relating to the precision and/or the permissible rotational speeds. They have raceways in the inner and outer ring which are staggered relatively to one another towards the bearing's axis and can accommodate high radial and axial loads in one direction at the same

time. The force generated by radial loads in the bearing and applied in the direction of the axis must be compensated by an external opposing force. That is why they are always arranged against a second bearing. The spindle bearings are usually delivered with an universal design. They are dimensioned in such a way that they can be combined in any configuration. Thanks to the standardized outer dimensions it is possible to exchange them for one another and with sector-specific products.

1.1.1. Spindle bearings

Spindle bearings are manufactured in series B719, B70, B72 and A73. Even different material combinations and designs are possible, as described in the following chapters.



Fig. 1.1. Spindle bearing

This rugged design is suited for many applications where there is a demand for a high load-bearing capacity and at the same time high rotational speeds.

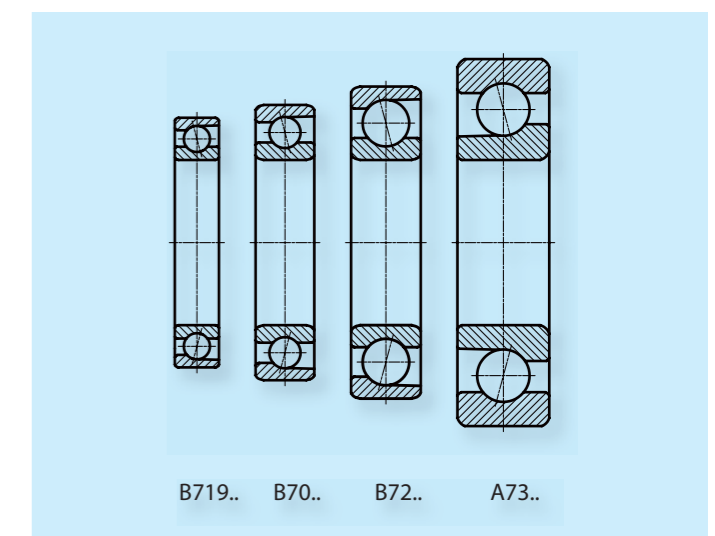

Fig. 1.2. Series of high-speed spindle bearings

1.1.2. High-speed spindle bearings

Based on their main dimensions, high-speed spindle bearings are identical to the B line of spindle bearings. They are distinguished in particular by their suitability for higher speeds, low friction and less heat development.

High-speed spindle bearings are available in the series HS719 and HS70 as well as in different designs and material combinations.



Fig. 1.3. High-speed spindle bearing

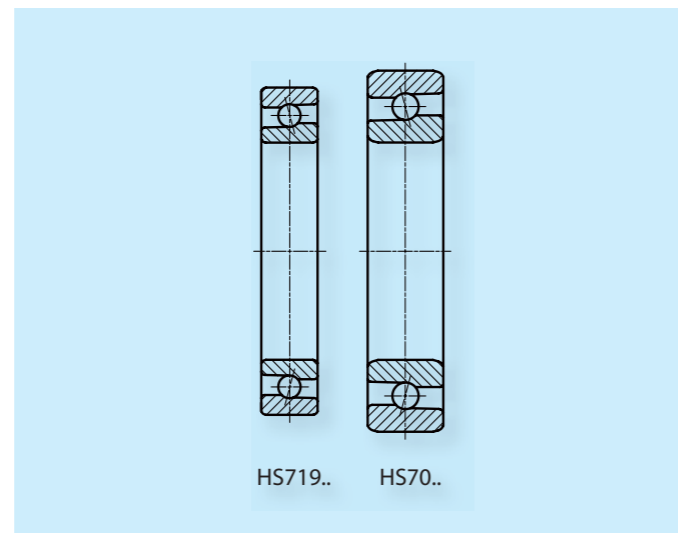

Fig. 1.4. Series of high-speed spindle bearings

1.2. Tolerances and standards

The main dimensions of the spindle bearings fulfill the general dimension plans for bearings according to DIN 616 (ISO 15). They are manufactured in dimensional series 19, 10, 02 and 03. The B719 and B70 series of bearings are designed in accordance with DIN 628-6.

1.3. Designs

To facilitate the installation of the cage and ensure the best possible lubrication of the bearing during operation, one ring with a reduced rib diameter shall be used at least. The bearings are not dismountable.

Design	SLF-Series
B	B719, B70, B72
A	A73
HS	HS719, HS70

1.4. Materials

1.4.1. Outer and inner rings, balls

SLF bearings are manufactured using vacuum degassed 100Cr6 chromium steel or a comparable material. The high degree of purity of the material ensures maximum reliability. The steel allows operating temperatures not exceeding 150°C without adversely affecting dimensional stability and hardness. Spindle bearings with ceramic balls and/or rolling bearing rings made of Cronidur 30 are used for special applications (see Section 4. Hybrid spindle bearings).

1.4.2. Cage

Spindle bearings are generally equipped with a one-piece, solid window-type cage that is guided in the outer rib and constructed of a laminated fabric (cotton fabric that is impregnated with phenolic resin). This material ensures the production of compact, precise cages that are suited for high speeds. Since the cage, which is made of a laminated fabric, cannot be used at operating temperatures > 100°C, we recommend using brass cages or PEEK cages.

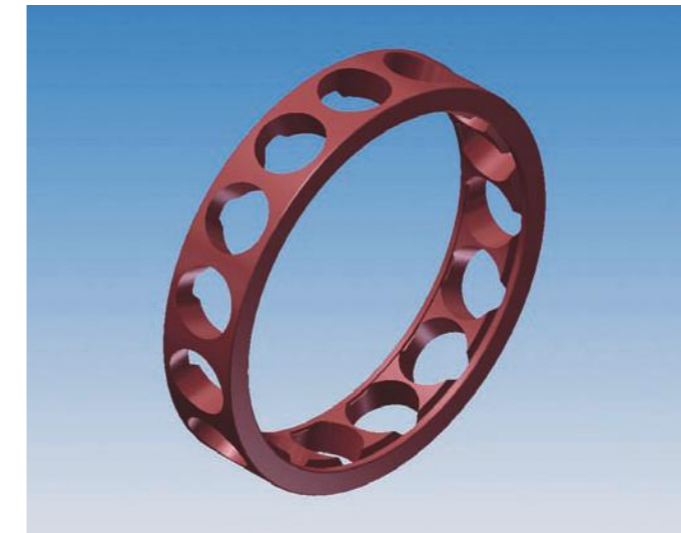

Fig. 1.5. Laminated phenolic resin cage



Fig. 1.6. Brass cage

1.5. Contact angle

The contact angle α is determined by the straight between the contact points ball/raceway and the radial plane. External loads are transferred from one bearing ring to another in the direction of the straights. To satisfy the different operating conditions, spindle bearings are usually manufactured with two different contact angles.

Contact angle	Code
15°	C
25°	E

Other contact angles are possible upon request as an alternative. It must also be noted that the axial rigidity increases with the increasing contact angle, while the radial rigidity is smaller. Moreover, the size of the contact angle influences the speed limit, i.e. the greater the contact angle, the lower the speed limit. The contact angle is determined by design and may change under operating conditions, such as different operating temperatures of the bearing rings and centrifugal forces at maximum rotational speeds, external forces.

2.1. Tolerances and tolerance classes

The following tolerance classes apply as a rule to the dimension and run-out tolerances of the spindle bearings:

Tolerance classes	Standards
P4 and P2	according to DIN 620-2
P4S	according to DIN 628-6 (Standard)
P2S	according to SLF in-house standard

To ensure a wide variety of applications and thus a high quality in terms of use, spindle bearings are normally manufactured at SLF for the tolerance class P4S, i.e. the connection parameters of the bearings have a P4 quality and important parameters for running characteristics, such as radial run-out, have P2 tolerances.

Tolerance class P4

Inner ring (Dimensions in mm)												
Nominal bore diameter	over to	10 18	18 30	30 50	50 80	80 120	120 180	180 250	250 315	315 400	400 500	
Tolerance class P4 (Tolerances in μm)												
Deviation	$\Delta_{\text{dmp}}, \Delta_{\text{ds}}^{1)}$	0 -4	0 -5	0 -6	0 -7	0 -8	0 -10	0 -12	0 -15	0 -19	0 -23	
Roundness $V_{\text{dp}/2}$	Diameter series 7 • 8 • 9	2	2,5	3	3,5	4	5	6	7,5	9,5	11	
	0 • 1 • 2 • 3 • 4	1,5	2	2,5	2,5	3	4	4,5	6	7	8,5	
Variation	V_{dmp}	2	2,5	3	3,5	4	5	6	8	10	12	
Width deviation	Δ_{Bs}	0 -80	0 -120	0 -120	0 -150	0 -200	0 -250	0 -300	0 -350	0 -400	0 -450	
Width variation	V_{Bs}	2,5	2,5	3	4	4	5	6	7	8	9	
Radial runout	K_{ia}	2,5	3	4	4	5	6	8	8	10	10	
Variation in inclination of outside cylindrical surface to bore	S_{d}	3	4	4	5	5	6	7	7	8	9	
Assembled bearing inner ring face runout with raceway (axial runout)	S_{ia}	3	4	4	5	5	7	8	10	12	13	

¹⁾ Those data Δ_{ds} and Δ_{Ds} are only valid for diameter series 0 • 1 • 2 • 3 • 4.

Outer ring (Dimensions in mm)												
Nominal outside diameter	over to	18 30	30 50	50 80	80 120	120 150	150 180	180 250	250 315	315 400	400 500	500 630
Tolerance class P4 (Tolerances in μm)												
Deviation	$\Delta_{\text{Dmp}}, \Delta_{\text{Ds}}^{1)}$	0 -5	0 -6	0 -7	0 -8	0 -9	0 -10	0 -11	0 -13	0 -15	0 -20	0 -25
Roundness $V_{\text{Dp}/2}$	Diameter series 7 • 8 • 9	2,5	3	3,5	4	4,5	5	5,5	6,5	7,5	9	11
	0 • 1 • 2 • 3 • 4	2	2,5	2,5	3	3,5	4	4	5	5,5	7	8,5
Variation	V_{Dmp}	2,5	3	3,5	4	5	5	6	7	8	9	11
Width deviation	V_{Cs}	2,5	2,5	3	4	5	5	7	7	8	9	10
Radial runout	K_{ea}	4	5	5	6	7	8	10	11	13	14	17
Variation in inclination of outside cylindrical surface to outer ring side face	S_{D}	4	4	4	5	5	5	7	8	10	10	12
Assembled bearing outer ring face runout with raceway (axial runout)	S_{ea}	5	5	5	6	7	8	10	10	13	15	18

The width tolerance Δ_{Cs} is identical to Δ_{Bs} for the associated inner ring.

Tolerance class P4S

Inner ring (Dimensions in mm)													
Nominal bore diameter	over to	0 10	10 18	18 30	30 50	50 80	80 120	120 150	150 180	180 250	250 315	315 400	400 500
Tolerance class P4S (Tolerances in μm)													
Deviation	$\Delta_{\text{dmp}}, \Delta_{\text{ds}}$	0 -4	0 -4	0 -5	0 -6	0 -7	0 -8	0 -10	0 -10	0 -12	0 -15	0 -19	0 -23
Roundness $V_{\text{dp}}/2$	Row 8•9	2	2	2,5	3	3,5	4	5	5	6	7,5	9,5	11
	Row 0•2•3	1,5	1,5	2	2,5	2,5	3	4	4	4,5	6	7	8,5
Variation	V_{dmp}	2	2	2,5	3	3,5	4	5	5	6	8	10	12
Width deviation	Δ_{Bs}	0 -40	0 -80	0 -120	0 -120	0 -150	0 -200	0 -250	0 -250	0 -300	0 -350	0 -400	0 -450
Width variation	V_{Bs}	1,5	1,5	1,5	1,5	1,5	2,5	2,5	4	5	6	7	8
Radial runout	K_{ia}	1,5	1,5	2,5	2,5	2,5	2,5	2,5	5	5	6	7	8
Variation in inclination of outside cylindrical surface to bore	S_{d}	1,5	1,5	1,5	1,5	1,5	2,5	2,5	4	5	6	7	8
Assembled bearing inner ring face runout with raceway (axial runout)	S_{ia}	1,5	1,5	2,5	2,5	2,5	2,5	2,5	5	5	7	9	11

Outer ring (Dimensions in mm)													
Nominal outside diameter	over to	10 18	18 30	30 50	50 80	80 120	120 150	150 180	180 250	250 315	315 400	400 500	500 630
Tolerance class P4S (Tolerances in μm)													
Deviation	$\Delta_{\text{Dmp}}, \Delta_{\text{Ds}}$	0 -4	0 -5	0 -6	0 -7	0 -8	0 -9	0 -10	0 -11	0 -13	0 -15	0 -18	0 -22
Roundness $V_{\text{Dp}}/2$	Row 8•9	2	2,5	3	3,5	4	4,5	5	5,5	6,5	7,5	9	11
	Row 0•2•3	1,5	2	2,5	2,5	3	3,5	5	4	5	5,5	7	8,5
Variation	V_{Dmp}	2	2,5	3	3,5	4	5	5	6	7	8	9	11
Width variation	V_{Cs}	1,5	1,5	1,5	1,5	2,5	2,5	2,5	4	5	7	7	8
Radial runout	K_{ea}	1,5	2,5	2,5	4	5	5	5	7	7	8	9	11
Variation in inclination of outside cylindrical surface to outer ring side face	S_{D}	1,5	1,5	1,5	1,5	2,5	2,5	2,5	4	5	7	8	9
Assembled bearing outer ring face runout with raceway (axial runout)	S_{ea}	1,5	2,5	2,5	4	5	5	5	7	7	8	10	12

The width tolerance Δ_{Cs} is identical to Δ_{Bs} for the associated inner ring.

Tolerance class P2

Inner ring (Dimensions in mm)												
Nominal bore diameter	over to	10 18	18 30	30 50	50 80	80 120	120 150	150 180	180 250	250 315	315 400	
Tolerance class P2 (Tolerances in μm)												
Deviation	$\Delta_{\text{dmp}}, \Delta_{\text{ds}}$	0 -2,5	0 -2,5	0 -2,5	0 -4	0 -5	0 -7	0 -7	0 -8	0 -10	0 -13,5	
Roundness	$V_{\text{dp}}/2$	1,5	1,5	1,5	2	2,5	3,5	3,5	4	5	6	
Variation	V_{dmp}	1,5	1,5	1,5	2	2,5	3,5	3,5	4	5	6	
Width deviation	Δ_{Bs}	0 -80	0 -120	0 -120	0 -150	0 -200	0 -250	0 -300	0 -350	0 -400	0 -450	
Width variation	V_{Bs}	1,5	1,5	1,5	1,5	2,5	2,5	4	5	6	7	
Radial runout	K_{ia}	1,5	2,5	2,5	2,5	2,5	2,5	5	5	6	7	
Variation in inclination of outside cylindrical surface to bore	S_{d}	1,5	1,5	1,5	1,5	2,5	2,5	4	5	6	7	
Assembled bearing inner ring face runout with raceway (axial runout)	S_{ia}	1,5	2,5	2,5	2,5	2,5	2,5	5	5	7	7	

Outer ring (Dimensions in mm)												
Nominal outside diameter	over to	18 30	30 50	50 80	80 120	120 150	150 180	180 250	250 315	315 400	400 500	500 630
Tolerance class P2 (Tolerances in μm)												
Deviation	$\Delta_{\text{Dmp}}, \Delta_{\text{Ds}}$	0 -4	0 -4	0 -4	0 -5	0 -5	0 -7	0 -8	0 -8	0 -10	0 -12	0 -15
Roundness	$V_{\text{Dp}}/2$	2	2	2	2,5	2,5	3,5	4	4	5	6	8
Variation	V_{Dmp}	2	2	2	2,5	2,5	3,5	4	4	5	6	8
Width variation	V_{Cs}	1,5	1,5	1,5	2,5	2,5	2,5	4	5	7	8	9
Radial runout	K_{ea}	2,5	2,5	4	5	5	5	7	7	8	10	13
Variation in inclination of outside cylindrical surface to outer ring side face	S_{D}	1,5	1,5	1,5	2,5	2,5	2,5	4	5	7	8	10
Assembled bearing outer ring face runout with raceway (axial runout)	S_{ea}	2,5	2,5	4	5	5	5	7	7	8	10	13

The width tolerance Δ_{Cs} is identical to Δ_{Bs} for the associated inner ring.

Tolerance class P2S

Tolerances of tolerance class P2 that are further restricted are established as in-house tolerance class P2S.

These bearings satisfy the most stringent precision requirements and are suited for maximum rotational speeds.

Inner ring (Dimensions in mm)								
Nominal bore diameter	over to	0 10	10 18	18 30	30 50	50 80	80 120	120 150
Tolerance class P2S (Tolerances in µm)								
Deviation	$\Delta d_s, \Delta d_{mp}$	0 -2	0 -2	0 -2	0 -2,5	0 -4	0 -5	0 -6
Roundness $V_{dp}/2$	Row 8 • 9	1	1	1	1,5	2	2	2,5
	Row 0 • 2	1	1	1,5	1,5	1,5	2	2,5
Width deviation	ΔB_s	0 -25	0 -25	0 -25	0 -25	0 -25	0 -50	0 -50
Width variation	V_{B_s}	1	1	1	1,3	1,3	2	2
Radial runout	K_{ia}	1,3	1,3	1,5	1,5	2	2	2,5
Variation in inclination of outside cylindrical surface to bore	S_d	1,3	1,3	1,3	1,3	1,3	2	2
Assembled bearing inner ring face runout with raceway (axial runout)	S_{ia}	1,3	1,3	2	2	2	2	2,5

Outer ring (Dimensions in mm)								
Nominal outside diameter	over to	10 18	18 30	30 50	50 80	80 120	120 150	150 180
Tolerance class P2S (Tolerances in µm)								
Deviation	$\Delta D_s, \Delta D_{mp}$	0 -2,5	0 -3,5	0 -3,5	0 -3,5	0 -4	0 -4	0 -6
Roundness $V_{Dp}/2$	Row 8 • 9	1	2	2	2	2	2	3
	Row 0 • 2	1	1,5	1,5	1,5	2	2	2,5
Width variation	V_{C_s}	1	1	1	1,3	2	2	2
Radial runout	K_{ea}	1,5	2	2	2,5	3	3	3,5
Variation in inclination of outside cylindrical surface to outer ring side face	S_D	1,3	1,3	1,3	1,3	2,5	2,5	2,5
Assembled bearing outer ring face runout with raceway (axial runout)	S_{ea}	1,5	2	2	3	4	4	4

The width tolerance Δ_{C_s} is identical to Δ_{B_s} for the associated inner ring.

2.2. Dimension groups for spindle bearings

In case of spindle bearings, the dimension tolerances with regard to bore and outer diameter are divided into three ranges. The middle variation of the range is written down as

actual value in µm on the outer ring (e.g. < -3 >) or inner ring (e.g. < -1 >).

2.3. Rotational speeds

Spindle bearings are especially well suited for high rotational speeds. Factors that influence the rotational speed:

- Operating temperatures: special consideration of heat dissipation
- Lubrication: when lubricating with grease, only approx. 65% of the achieved speed of oil lubrication
- Dimensional series: The smaller the bearing's cross-section, the better it is suited for high speeds.
- Preload: The permissible speed decreases with the increasing preload.
- Installation layout: The max. speed is attained with the installation of a single bearing. In case of bearing sets consisting to two or more bearings, the speed reduces accordingly. (Section 7.4.)
- Contact angle: The speed limit decreases with the increasing contact angle.
- Precision: The speed limit increases with the increasing precision.
- Precise machining of the bearing seats
- Cage type: low cage weight means less imbalance; the guidance at the rib diameter of the outer ring also allows the cage to center itself.

Correction factors, with which the prescribed speeds are to be multiplied for the spindle bearings:

Bearing properties	Correction factor
Accuracy	
P4	0,9
P4S	1
P2	1,1
P2S	1,15
Contact angle	
15°	1
25°	0,9
Lubricant	
oil	1
grease	0,65

These values are guidelines, applicable to a fixed preloading under optimal working conditions like installation tolerances, operating temperatures, lubrication, etc. The dynamic balancing level is important for ensuring good movement.

2.4. Operating temperature

SLF spindle bearings are heat treated such that they are dimensionally stable up to an operating temperature of 150°C. The operating temperatures of the cages, the bearing seal and the lubricant can further restrict the upper operating temperature of the bearing.

Part	Upper temperature range
Roller bearing rings	150°C
Laminated phenolic resin cage (standard)	100°C
Brass cage	150°C
PEEK cage	approx. 260°C (up to 150°C without performance restrictions)
Sealing discs of NBR (2RSD)	110°C
Lubricant grease L75 (standard)	120°C

If it is possible, the bearing temperature at the outer ring should not exceed 80°C. If applicable, the bearings are to be cooled, e.g., by means of the housing cooling system or circulating oil lubrication.

2.5. Noise

The noise level of the spindle bearings is a sign of their quality and the running characteristics of the bearings. Since bearing noise is caused by any existing irregularities, undulation and roughness, particular attention is placed on ensuring maximum quality especially with regard to the above characteristics during production. Appropriate measuring technology is used to support this process. All bearings undergo full quality control testing with regard to noise with the aid of specific noise testing equipment, ensuring that we only deliver bearings that satisfy high standards. This test also provides feedback relating to the cleanliness of the bearings.

3.1. „U“ universal bearings

SLF production portfolio also includes bearings with universally matched designs (UL, UM, US). Universal bearings „U“ are defined such that both sides of the inner and outer ring are properly aligned when exposed to a predefined axial force (preload force). In real terms, this means that if the inner rings of two identical spindle bearings are axially loaded (O-configuration), the result is precisely the preload force indicated by the bearing manufacturer:

- light (UL)
- medium (UM)
- heavy (US).

The X-arrangement behaves in a similar fashion, whereas the outer rings of both bearings are axially tensioned here. Spindle bearings in universal design (same size and same design) can be installed in any arrangement. A uniform load distribution is best achieved with SLF bearing sets that are already matched to one another during production. SLF moreover offers the following options for enabling a simple warehousing and ensuring a high flexibility:

- Two-piece sets, e.g. with the suffix DUL. That stands for a duplex bearing pair, where the dimensions of the bore and cladding diameter matched to one another and can be installed both in O (DB), X (DF) or T (DT) configuration. The evenness thus imparted is especially important for high speeds and high level of accuracy and are recommended by SLF.
- Three-piece sets, e.g. with the suffix TUL along the lines of the two-piece sets
- Four-piece sets, e.g. with the suffix QUL along the lines of the two-piece sets

3.2. Bearing arrangements

3.2.1. O-arrangement (DB suffix)

The pressure lines drift apart in the direction of the bearing axis. That results in a large pitch on the bearing axis. A very rigid bearing against tilting moments is achieved by this arrangement and the bearing absorbs axial forces in both directions.

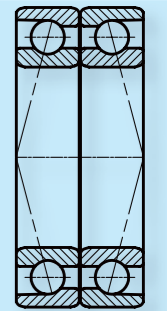

O-arrangement

3.2.2. X-arrangement (DF suffix)

The pressure lines merge in the direction of the bearing axis. That results in a small pitch on the bearing axis. The tilting rigidity is lesser compared to 3.2.1. The configuration is less sensitive to misalignment. The bearing pressure and elasticity is along the lines of the O configuration.

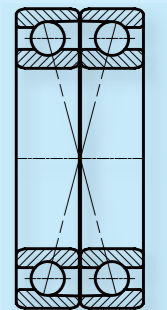

X-arrangement

3.2.3. Tandem-arrangement (DT suffix)

Both paired bearings are arranged parallel in the direction of the load, whereas a greater axial load than with individual bearings is possible in the direction of the load. Each of the two bearings accommodates an almost equal share of the axial load. It must be taken into account that the tandem pair must be preloaded in any case against a third bearing.

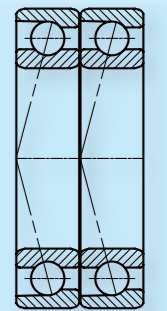

Tandem-arrangement

3.2.4. Multiple arrangement

In case of greater loads or demands for high rigidity, 3 or 4 or even 5 bearings in exceptional cases are assembled into sets and installed. Bearings matched in this manner are manufactured, marked and packaged at SLF either in pairs or sets. These bearings have the same measurements in terms of bore and outer diameter.

3.2.4.1. TO-arrangement (TBT suffix) and TX-arrangement (TFT suffix)

Both of these arrangement are used like the tandem arrangement to accommodate high axial loads in one direction. The additional third bearing is used for counter guidance and makes the multiple configuration a fixed bearing.

3.2.4.2. TOT-arrangement (QBC suffix) and TXT-arrangement (QFC suffix)

Both arrangement are used as fixed bearings for high radial loads and high axial loads. These arrangement result in a very high rigidity. It is not appropriate to install more than three bearings directly next to one another, since heat dissipation would be worse and the supply of lubricant to all bearings more difficult. That's why spacer rings are to be used here.

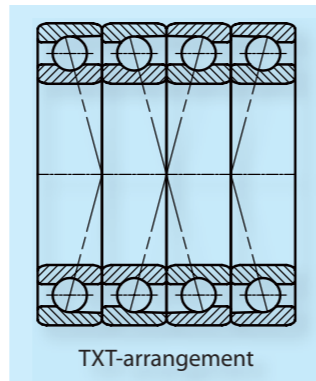
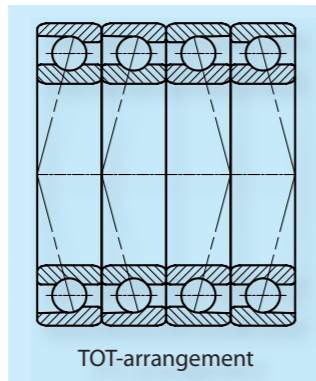
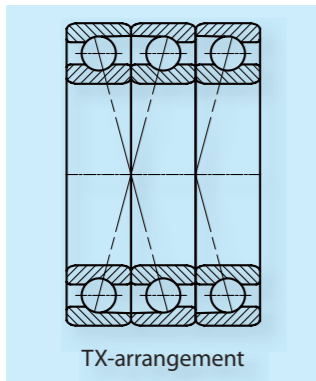
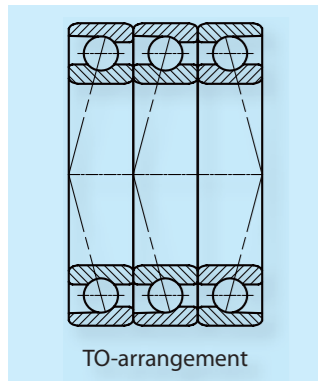

3.3. Distance rings

Installing spacer rings (an inner and an outer ring respectively) between the matched bearings should result in the following:

- The bearing pitch with X and O configuration is increased.
- Lubrication is improved, i.e. the supply of oil to every bearing is possible and there is a grease reserve in case of grease lubrication.
- The resulting frictional heat can be dissipated more readily.
- The use of spacer rings can change the preloading for the X and/or O configuration. In real terms, that means: the inner spacer ring has a flimsier design than the outer ring and the preloading decreases with the X configuration or it increases with the O configuration.
- The necessary measurement variances are available upon request.

During the production of spacer rings, particular attention must be placed on ensuring plane parallelism and evenness. Both spacer rings are to be surface-ground in a single step, if possible.

Tolerance class	P0, P6, P5, P4	P2
Difference in the widths of the inner and outer distance rings	3,0	2,0
Variation of width	2,5	1,3
Axial run-out	2,5	1,3

Hybrid spindle bearings are bearings with races consisting of bearing steel and balls made of a ceramic material (silicon nitride Si_3N_4) of maximum homogeneity and hardness. Ceramic balls are moreover lighter than steel balls. That results in less centrifugal forces and thus less friction. They are insulated with regard to electricity and they are not magnetic. They are also resistant to corrosion. These bearings are specifically designed as heavy-duty bearings for machine tool spindles and offer the prerequisites for a high productive capacity. Based on the positive characteristics of ceramics, the hybrid bearings are characterized by a considerably lower friction during operation and thus offer the following advantages compared to bearings with steel balls:

- approx. 20% higher rotational speeds
- better operation after lubrication-system failure
- higher stiffness
- less vibration
- less noise
- more favorable acceleration and deceleration performance

Hybrid bearings were originally used specifically for high speed applications. Based on nearly same service life as bearings with steel balls they are also used in all other series of bearings.



Fig. 4.1. Hybrid spindle bearing

Spindle bearings of sealed design (2RSD) are also included in the SLF production portfolio as in the bearing tables. The greasing of these maintenance-free bearings is coordinated such that the bearings have a low temperature while running at high speeds over long periods. Thanks to their relatively simple installation, lubrication and maintenance, they are the optimum solution for customers with long useful life requirements.

Bearings of same size and series in unsealed design can be replaced with similar bearings in sealed design.



Fig. 5.1. Spindle bearing in 2RSD design

In case of applications with oil-based minimum quantity lubrication, the lubricant can be directly supplied to the point of contact (ball/race) thanks to these designs.

The DLR design features a circumferential lubrication groove and hole approx. $\varnothing 0.5$ mm at outer ring. Two radial grooves with installed O rings made of NBR (standard) ensure an optimum seal to the spindle housing.

The user is responsible for making the feed hole in the appropriate location on the housing.

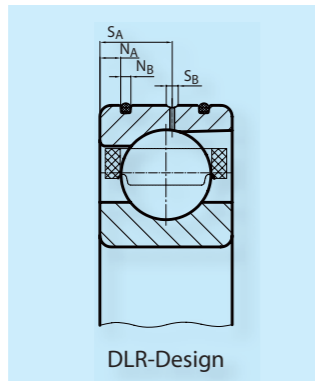

Fig. 6.1. Spindle bearing in DLR design

7.1. General

The design calculation for the basic load rating and service life of bearings is based on the standard DIN ISO 76 (Static Load Ratings) and DIN ISO 281 (Dynamic Load Ratings and Nominal Rating Life). These standards describe comprehensive design calculations. As a result, we will only focus on the fundamental design calculations below. These design calculations are used to provide an approximate assessment of a bearing.

More in-depth bearing evaluations are possible by calculating the Hertzian contact pressure between rolling elements and race while taking into account the actual lubrication conditions with the aid of specific calculation programs. Please contact our Design department in this regard.

7.2. Nominal Rating Life

The bearing's rating life is indicated by the number of revolutions or hours of running until the bearing shows the first signs of damage. The most frequent causes are wear and tear, seizing up, and overheating due to overloading (mechanical and thermal) as well as material fatigue. The most frequent cause for failure in high-speed applications is overheating followed by the bearing seizing up.

According to DIN ISO 281, the nominal rating life of a group of same model spindle bearings with the same contact angle is calculated as follows:

$$L_{10} = \left(\frac{K \cdot C_r}{P_r} \right)^3 \quad \text{in millions of revolutions}$$

$$L_{10h} = \frac{L_{10} \cdot 10^6}{60 \cdot n} \quad \text{in hours}$$

L_{10}	Nominal rating life in millions of revolutions with 10% failure probability
L_{10h}	Nominal rating life in hours with 10% failure probability
C_r	Dynamic radial load rating in N
K	Correction factor, depends on the number of spindle bearings „i“: $K=i^{0.7}$
P_r	Dynamic equivalent radial loading in N
F_a	Axial load of bearing group in N
F_r	Radial load of bearing group in N
n	Revolutions in min^{-1}

7.3. Equivalent dynamic loading

If bearing are exposed to radial and axial loading at the same time, these loads are compiled to an equivalent load for the purpose of calculating the rating life. The equivalent dynamic loading is calculated as follows:

$$P_r = X * F_r + Y * F_a \text{ (in N)}$$

Both factors X and Y depend on the ratio of the axial-to-radial load F_a/F_r while compared to the bearing-specific factor e.

Individual bearings or tandem-arrangement			$F_a/F_r \leq e$		$F_a/F_r > e$	
a	$F_a/(i * C_0)$	e	X	Y	X	Y
15°	0,015	0,38	1	0	0,44	1,47
15°	0,029	0,4	1	0	0,44	1,4
15°	0,058	0,43	1	0	0,44	1,3
15°	0,087	0,46	1	0	0,44	1,23
15°	0,12	0,47	1	0	0,44	1,19
15°	0,17	0,5	1	0	0,44	1,12
15°	0,29	0,55	1	0	0,44	1,02
15°	0,44	0,56	1	0	0,44	1,0
15°	0,58	0,56	1	0	0,44	1,0
25°	-	0,68	1	0	0,41	0,87

Bearings installed in X- or O- arrangement			$F_a/F_r \leq e$		$F_a/F_r > e$	
a	$F_a/(i * C_0)$	e	X	Y	X	Y
15°	0,015	0,38	1	1,65	0,72	2,39
15°	0,029	0,4	1	1,57	0,72	2,28
15°	0,058	0,43	1	1,46	0,72	2,11
15°	0,087	0,46	1	1,38	0,72	2,0
15°	0,12	0,47	1	1,34	0,72	1,93
15°	0,17	0,5	1	1,26	0,72	1,82
15°	0,29	0,55	1	1,14	0,72	1,66
15°	0,44	0,56	1	1,12	0,72	1,63
15°	0,58	0,56	1	1,12	0,72	1,63
25°	-	0,68	1	0,92	0,67	1,41

7.4. Calculation of speed limit

The number of bearings, their arrangement, loading (air or preloading), outer load and lubrication on the one hand and heat dissipation on the other hand are decisive factors for speed. The speeds indicated in the bearing tables are to be considered as guidelines and may vary in both directions depending on the above conditions. The cited speeds are not attained in case of installation of rigidly preloaded bearings as well as pairs and sets of bearings. The following table outlines the corresponding factor for calculating the appropriate speed. This results in any case in a speed reduction.

Rotational speed reduction for spindle bearing sets (n • f _r)					
Bearing spacing large		Factor f _r			
		Bearing preload			
		light	medium	heavy/high	
		L	M	S	
∅	∅	0,85	0,75	0,50	
∅∅	∅∅	0,80	0,70	0,50	
∅∅∅	∅∅	0,75	0,65	0,45	
Fixed bearing	Movable bearing	L	M	S	
∅∅	∅∅	0,75	0,60	0,35	
∅∅	∅∅	0,65	0,50	0,30	
∅∅∅	∅∅	0,65	0,50	0,30	
∅∅∅∅	∅∅	0,72	0,57	0,37	
∅∅∅∅	∅∅	0,54	0,40	0,37	

n corresponds to the rotational speed according to the catalogue

7.5. Suspension and stiffness

Thanks to bearings free of clearance, a very high running accuracy is achieved even when subject to varying loads. The required stiffness and the type of loading determine how the bearings are arranged and preloaded. Arranging bearings in sets significantly increases the stiffness. The values indicated in the bearing tables for axial stiffness are for bearing pairs in O or X arrangement. Bearing sets with three or more bearings yield higher values for axial stiffness. The radial stiffness can be calculated with the aid of a factor from the axial stiffness as follows:

$$S_r \approx 6 * S_a \text{ für } \alpha = 15^\circ$$

$$S_r \approx 2 * S_a \text{ für } \alpha = 25^\circ$$

If more than two bearings are combined into sets, the axial stiffness is increased. The following table illustrates the calculation of this stiffness for concentrically acting axial force.

Combination	S _a	K _a E (lifting force)
	N/μm	α = 15° und α = 25° N
DB	S _a	3 * F _V
TBT	1,64 * S _a	6 * F _V
QBC	2 * S _a	6 * F _V
QBT	2,24 * S _a	9 * F _V

7.6. Load-bearing capacity

The dynamic load rating for bearing sets with bearings matched in any configuration is obtained by multiplying the load rating C for the individual bearing with

- 1,62 for sets with 2 bearings
- 2,16 for sets with 3 bearings
- 2,64 for sets with 4 bearings
- 3,09 for sets with 5 bearings

The static load rating is obtained by multiplying the table-cited value C₀ with 2 or 3, 4 or 5.

7.7. Preloading

The predefined axial forces (preload forces) are: light (L), medium (M) and heavy (S). The preload forces indicated in the bearing tables apply to the axial pretensioning of bearing pairs (in O- or X- arrangement). In case of a combination of more than two bearings, the preloading values are to be multiplied as follows.

Combination	Factor
DB, DF	1
TBT, TFT	1,35
QBC, QFT	1,6
QBC, QFC	2

Preloading refers to a constant axial loading that is applied to the bearing. It has a major impact on

- the attainable speeds
- the stiffness
- the permissible loads

The pretensioning should only be as large as is necessary. The standard design has a light pretensioning (UL), which may be generated firmly (bearings pretensioned against one another) or elastically (with springs).

Fixed preloading (axially mounted):

- thermal effects may increase considerably – major impact on max. attainable speed.

Elastic preloading (springs):

- thermal effect is eliminated for the most part with springs – max. attainable speeds are hardly influenced. In case of high speeds, a minimum preloading is necessary. This depends on the outer axial load. The lifting force is the limit of the outer axial load, above which the impact of the preloading is raised in case of disburdened ball valves.

The related effects include:

- Balls and races are no longer constantly in contact
- Sliding friction increases
- Wear increases
- Useful life decreases

8.1. Machining tolerances of the parts surrounding the bearings

The high capacity of spindle bearings is only guaranteed if the accuracy of the relevant adjacent parts are adapted according to the precision of bearings. This is necessary since the rings of the spindle bearings, especially the dimensional series with low cross-sections, adapt to the shape of the shaft or the housing bore. This can result in defects in form and misalignment, which cause increased operating temperatures. The higher the required speeds and levels of precision are for the bearing, the more these faults become evident. The average roughness R_a of the bearing seats must be complied with in order to ensure that the corresponding fit only varies very slightly in case of installation (smoothing of surfaces).

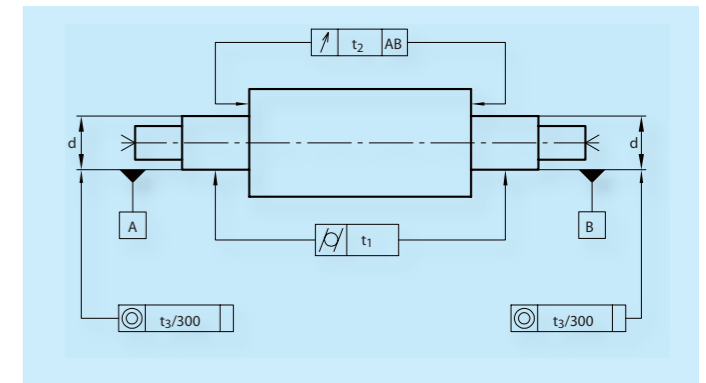

Fig. 8.1. Machining of shaft

8.2. Guidelines for machining of shafts

Dimension for d	Tolerance class of bearing	General recommendation a. p. ISO 286	Nominal size of shaft d (in mm)												
			over to	6 10	10 18	18 30	30 50	50 80	80 120	120 180	180 250	250 315	315 400	400 500	
Dimensions and tolerances - empirical values (in μm)															
light seat	P5/P4/P4S	h4		0 -4	0 -4	0 -4	0 -6	0 -6	0 -8	0 -9	0 -11	0 -12	0 -14	0 -15	
	P2/P2S	h3		0 -3	0 -3	0 -3	0 -4	0 -4	0 -5	0 -6	0 -8	0 -10	0 -10	0 -12	
fixed seat	P5/P4/P4S	js4		2 -2	2,5 -2,5	3 -3	3,5 -3,5	4 -4	5 -5	6 -6	7 -7	8 -8	9 -9	10 -10	
	P2/P2S	js3		1,25 -1,25	1,5 -1,5	2 -2	2 -2	2,5 -2,5	3 -3	4 -4	5 -5	6 -6	6,5 -6,5	7,5 -7,5	
Cylindrical form t_1	P5/P4/P4S	IT0		1	1	1	1,5	1,5	1,5	2	3	4	5	6	
	P2/P2S			0,5	0,5	0,8	1	1	1	1,2	2	2,5	3	4	
Axial run-out t_2	P5/P4/P4S	IT1		1	1	1	1,5	1,5	2,5	3,5	4,5	6	7	8	
	P2/P2S			0,5	0,5	0,8	1	1	1,5	2	3	4	5	6	
Concentricity t_3	P5/P4/P4S	IT3		2	2	2	3	3	4	5	7	8	9	10	
	P2/P2S			1	1	1	2	2	2,5	3,5	4,5	6	7	8	
Average roughness R_a				0,2	0,2	0,2	0,2	0,4	0,4	0,4	0,4	0,8	0,8	0,8	

8.3. Guidelines for machining of housing bores

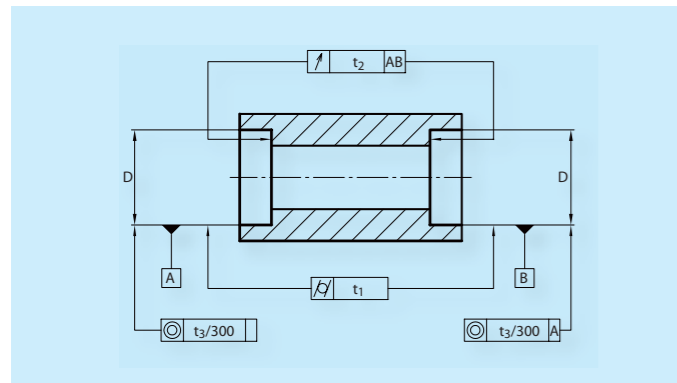

Fig. 8.2. Machining of housing bores

Nominal size of housing bore D (in mm)															
Dimension for D	Tolerance class of bearing	General recommendation a. p. ISO 286	over to	10	18	30	50	80	120	180	250	315	400	500	630
Dimensions and tolerances - empirical values (in µm)															
Floating bearings	P5/P4/P4S	H5		12 2	12 2	12 2	15 5	15 5	15 5	21 7	24 8	27 9	30 10	33 11	
	P2/P2S	H4		5 0	5 0	7 2	10 2	10 4	12 4	14 4	16 5	18 5	20 6	22 7	
Fixed bearings	P5/P4/P4S	JS5		10 0	10 0	10 0	12 2	12 2	12 2	12 2	14 2	15 2	16 2	19 3	
	P2/P2S	JS4		3 -2	3 -2	3 -2	5 -3	5 -3	5 -3	7 -4	8 -4	9 -5	10 -5	11 -6	
Cylindrical form t_1	P5/P4/P4S	IT1		1,5 1	1,5 1	1,5 1	2 1,5	2 1,5	3 2	4,5 3	6 4	7 5	8 6	9 7	
	P2/P2S														
Axial runout t_2	P5/P4/P4S	IT2		1,5 1	1,5 1	1,5 1	2 1,5	5 1,5	3 2	4,5 3	6 4	7 5	8 6	9 7	
	P2/P2S														
Concentricity t_3	P5/P4/P4S	IT3		5 4	5 4	6 5	6 5	8 6	8 6	10 8	12 9	13 10	15 11	16 12	
	P2/P2S														
Average roughness R_a				0,4	0,4	0,4	0,4	0,8	0,8	0,8	1,6	1,6	1,6	1,6	

9.1. Preparation of installation

Super precision bearings fulfill the stringent requirements on cleanliness and precision. The bearings should be installed in a room that is as clean as possible and free of dust with regulated temperature. Prior to installing the bearings, the dimensional accuracy of the connecting parts must be checked. Only provide and use tools that are suited for installation. In case of bearing sets, preferably combine bearings that have the same diameter grades (actual values). Only open the bearing packages right before the installation. Remove excessive anti-corrosion oil with the aid of a clean lint-free cloth.

9.2. Greasing of bearings

In case of greasing and incompatibility of the anti-corrosion oil with the provided grease, the bearings are to be washed using a low-viscosity oil or kerosene and dry. Afterwards, grease the bearings with the recommended amount of grease with the aid of syringe or spatula in the same amount between the rolling elements, preferably the inner race, and then turn by hand to ensure that the grease is distributed evenly in the bearing. (The information on recommended amount of grease can be found in Section 23.2.3. Amount of grease.)

9.3. Bearing installation

9.3.1. Installation with press

Apply a thin film of oil to the shaft. During pressing, no forces may be transferred via the rolling elements. Press the bearing on evenly over the inner ring up to the shaft shoulder with the aid of a suitable installation tool. Avoid a canting of the rings.

9.3.2. Installation with high bearing temperature

Heating up the inner ring, e.g. by using an inductive heating device simplifies the installation of the inner rings. The greater the overlap of the inner race fit, the greater the temperature must be. This may not exceed 120°C, however. Subsequent temperature differences in Kelvin (K) are recommended:

Shaft tolerance/Bore	j5	k5	m5	n6	p6	r5
d < 80	50	60	70	80	100	100
80 < d ≤ 180	40	40	45	55	65	75
180 < d ≤ 315	30	35	40	45	50	60
315 < d ≤ 500	30	30	35	40	45	55

After cooling the inner ring, press on the shaft should again and check the axial and radial running accuracy.

9.4. Bearing securing

9.4.1. Fastening with precision nuts

The inner rings are tensioned with a lock nut. The recommended tightening torque creates the clamping force that safely overcomes the preloading of the bearings in case of an O or multiple bearing arrangement. To avoid any signs of setting, first tighten the nuts with two to three times the tightening torque, then loosen and tighten the nuts to the recommended tightening torque.

BKZ	Bore number
d	Bore diameter in mm
Ma	Tightening torque in Nm
Fz	Resulting clamping force in kN

Recommended tightening torques for axial tension of the bearing inner rings with the aid of nut

BKZ	d	Thread	Series 719		Series 70		Series 72	
			Ma	Fz	Ma	Fz	Ma	Fz
02	15	M15x1	1,54	0,85	1,98	1,09	2,13	1,17
03	17	M17x1	1,49	0,73	2,28	1,12	2,66	1,30
04	20	M20x1	2,52	1,06	3,99	1,68	5,17	2,18
05	25	M25x1,5	3,91	1,30	6,31	2,10	7,89	2,63
06	30	M30x1,5	6,97	1,96	9,77	2,75	13,5	3,78
07	35	M35x1,5	9,35	2,28	14,5	3,52	20,6	5,01
08	40	M40x1,5	14,6	3,13	19,1	4,11	27,4	5,88
09	45	M45x1,5	18,2	3,49	24,5	4,70	32,4	6,22
10	50	M50x1,5	20,6	3,57	29,0	5,03	37,6	6,53
11	55	M55x2	28,9	4,52	42,1	6,59	52,6	8,22
12	60	M60x2	31,5	4,53	50,3	7,24	72,5	10,4
13	65	M65x2	39,4	5,25	57,6	7,67	96,1	12,8
14	70	M70x2	52,2	6,48	76,6	9,51	113	14,0
15	75	M75x2	60,9	7,08	87,3	10,1	120	14,0
16	80	M80x2	71,4	7,79	106	11,6	148	16,1
17	85	M85x2	105	10,8	124	12,7	193	19,8
18	90	M90x2	107	10,4	153	14,9	231	22,5
19	95	M95x2	110	10,2	169	15,7	276	25,5
20	100	M100x2	161	14,1	187	16,5	339	29,8
21	105	M105x2	163	13,6	214	18,0	381	31,9
22	110	M110x2	178	14,3	273	21,9	458	36,7
24	120	M120x2	238	17,5	322	23,7	512	37,7
26	130	M130x2	309	21,1	442	30,1	653	44,5

BKZ	d	Thread	Series 719		Series 70		Series 72	
			Ma	Fz	Ma	Fz	Ma	Fz
28	140	M140x2	357	22,6	509	32,2	886	56,1
30	150	M150x2	494	29,2	598	35,4	1 172	69,4
32	160	M160x3	564	31,1	765	42,1	1 509	83,1
34	170	M170x3	634	32,9	903	46,9	1 738	90,2
36	180	M180x3	831	40,8	1 217	59,8	1 933	94,9
38	190	M190x3	922	42,9	1 349	62,8	2 392	111
40	200	M200x3	1 172	51,9	1 550	68,6	2 916	129
44	220	Tr220x4	1 417	56,8	2 185	87,6	3 863	155
48	240	Tr240x4	1 675	61,7	2 578	94,9		
52	260	Tr260x4	2 474	84,2				
56	280	Tr280x4	2 853	90,3				
60	300	Tr300x4	3 952	117				
64	320	Tr320x5	4 495	124				
68	340	Tr340x5	5 051	132				
72	360	Tr360x5	5 640	139				
84	420	Tr420x5	8 718	185				
92	460	Tr460x5	12 991	252				
500	500	Tr500x5	16 000	285				

9.4.2. Fastening with housing cover

Especially in case of an X arrangement and fixed bearing, the outer rings are usually preloaded with the housing cover. Since the width tolerance especially of the adjusted spindle bearings is relatively large, the cover must be adjusted in particular. Prior to tightening the cover screws, it is necessary to ensure that the following gap is maintained between the cover and the housing.

Bearing bore	Housing cover gap a
<= 100 mm	0,01 to 0,03 mm
> 100 mm	0,02 to 0,04 mm

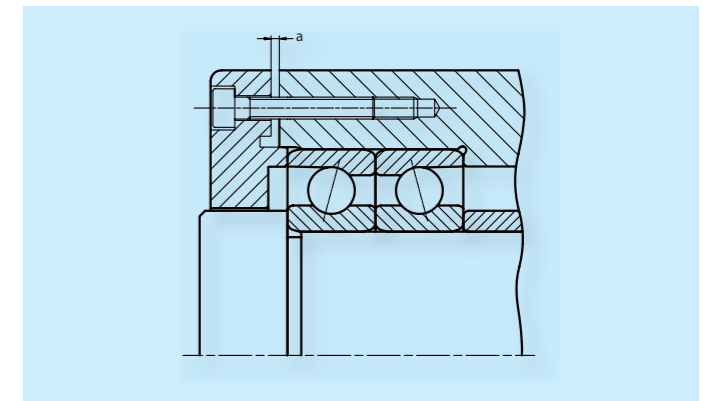

Fig. 9.1. Fastening with housing cover

10.1. Content and location of label

The rolling bearings usually have a labelling with the following contents:

- SLF brand name
- Product designation, e.g. „B71910C.T.P4S.UL“
- Country of production: MADE IN GERMANY
- In-plant information for production period, e.g. „121H“

The bearing label is usually located on the flat side of the outer ring. In case of spindle bearings, the actual dimensions of the outer diameter and bore as well as the width are provided as current value in µm as follows:

Outer ring	Example
The actual outer diameter and width are indicated between product designation and „MADE IN GERMANY“.	<- 3/ - 80 >
< Dimension outer diameter/dimension width >	
Inner ring	Example
Actual bore diameter.	<- 1 >
< Dimension bore diameter >	

If the marking is only provided on the inner ring:

Inner ring	Example
The actual bore and outer diameter and width are indicated between product designation and „MADE IN GERMANY“.	<- 1/ - 3/ - 80 >
< Dimension bore diameter/dimension outer diameter/dimension width >	

The actual bearing width is written without deviation on the label of the package (e.g. * -1/-3 *). The inner ring is labelled on a spot with the greatest wall thickness (race to bore) with a line.

10.2. Labelling schema for spindle bearings

	B	719	10	C.	DLR.	2RSD.	T.	P4S.	U	L.	L252		
Design												Grease filling	
Bearing series												Pretensioning	
Bore size												Bearing arrangement	
Contact angle												Precision	
Direct lubrication												Cage	
Design												Seal	
B	Standard with steel balls											2RSD	sealed and greased on both sides
HCB	Standard with ceramic balls											RSDO	sealed on one side, disc on the side of the large outer ring/rib diameter, ungreased
XCB	Standard with ceramic balls, rolling bearing rings made of Cronidur 30											RSDX	sealed on one side, disc on the side of the small outer ring/rib diameter, ungreased
A	Standard with steel balls											Cage	
HS	High speed bearings with steel balls											T	Window cage made of laminated fabric, guide on outer ring
HC	High speed bearings with ceramic balls											MPA	Window cage made of brass, guide on outer ring
XC	High speed bearings with ceramic balls, rolling bearing rings made of Cronidur 30											ENPA	Window cage made of PEEK, guide on outer ring
Bearing series												Precision	
719	light series											P4S	Standard design according to in-house standard (run-out tolerances after P2)
70	medium series											K5	with additionally restricted bore and outer diameter tolerance of the respective tolerance class
72	medium-heavy series											P4	as per DIN 620-2
73	heavy series											P2	as per DIN 620-2
Bore size												P2S	Tolerance as per in-house standard better than P2
02	15 mm											Bearing arrangement	
03	17 mm											U	Individual bearing suited for any configuration, designation of bearing sets in Section 3.2.
04	4*5 = 20 mm											Pretensioning	
05	5*5 = 25 mm											L	light
06	6*5 = 30 mm (etc.)											M	medium
Contact angle												S	heavy
C	15°											Grease filling	
E	25°											-	without
Direct lubrication												-	for sealed bearings by default L75; or L252 as alternative
DLR	Circumferential groove and radial feed hole and two radial grooves with O rings at the outer diameter											L75	L75 Klüberspeed Bf 72-22 from Klüber
												L252	L252 Turmgrease Highspeed from Lubcon

11. Converting other makes to SLF product designation

Make	SLF	FAG	SKF	SNFA	NSK	GMN
Series						
B719	B719..	B719..	719..	SEB..	79..	S619
B70	B70..	B70..	70..	EX..	70..	S60
B72	B72..	B72..	72..	E2..	72..	S62.
A73	A73..		73..			
HS719	HS719..	HS719..	719..(A)CE			
HS70	HS70..	HS70..	70..(A)CE			
Contact angle						
15°	C	C	CD	1	C	C
25°	E	E	ACD	3	A5	E
Sealing						
B7...	.2RSD	-2RSD				
HS7...	.2RSD	HSS7...				
Cage made of						
laminated fabric	.T(TPA)	-T(TPA)	ohne	CE	TR	TA
Brass	.MPA	-MPA		L		
Universal design						
Individual bearing	.U	-U	G	U	SU	U
Bearing pair	.DU	-DU	DG	DU	DU	DU
Bearing sets						
2 bearings in O-arrangement	.DB	-DB	DB	DD	DB	DB
2 bearings in X-arrangement	.DF	-DF	DF	FF	DF	DF
2 bearings in T-arrangement	.DT	-DT	DT	T	DT	DT
3 bearings in TO-arrangement	.TBT	-TBT	TBT	TD	DBD	TBT
3 bearings in TX-arrangement	.TFT	-TFT	TFT	TF	DFD	TFT
3 bearings in T-arrangement	.TT	-TT				TDT
4 bearings in TOT-arrangement	.QBC	-QBC	QBC	TDT	DBB	QBC
4 bearings in TXT-arrangement	.QFC	-QFC	QFC	TFT	DFD	QFC
4 bearings in 3TO-arrangement	.QBT	-QBT	QBT	3TD	DBT	
4 bearings in 3TX-arrangement	.QFT	-QFT	QFT	3TF	DFT	
4 bearings in T-arrangement	.QT	-QT	QT			QTC

11. Converting other makes to SLF product designation

Make	SLF	FAG	SKF	SNFA	NSK	GMN
Pretensioning						
Light	L	L	A	L	L	L
Medium	M	M	B	M	M	M
Heavy	S	H	C	F	H	S
Individual	U..(N)					V
Precision						
P4	P4	P4	P4A	7	P4	P4
P4S	P4S	P4S		P4A		
P2	P2	P2	PA9A	9	P2	P2
P2S	P2S					A9

12. Measurement tables

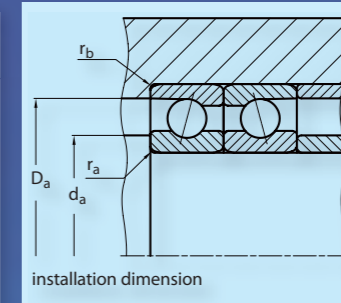
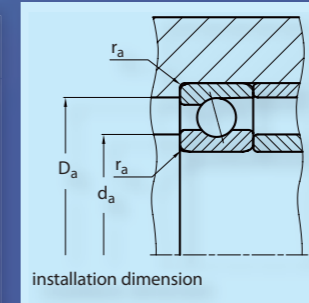
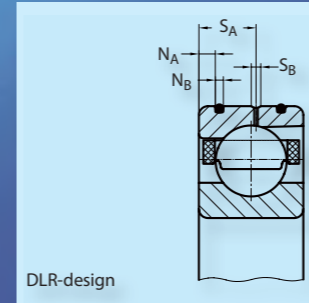
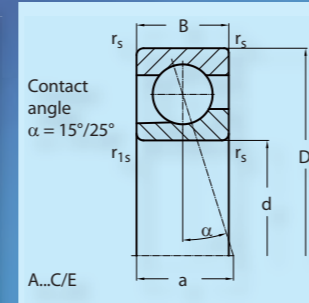
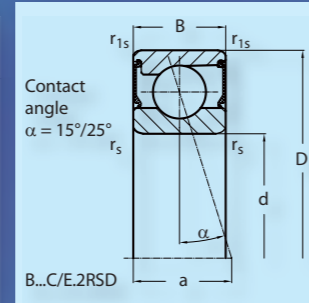
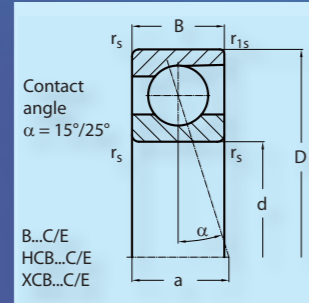

12. Measurement tables

12.1. Spindle bearing

Shaft	dimension (mm)						installation dimension (mm)				DLR-dimension (mm)				preload (N)			axial rigidity (N/μm)			load rating (kN)		speed limit (min ⁻¹)		Code	weight
	d	D	B	a	r _s min	r _{1s} min	d _a h12	D _a H12	r _a max	r _b max	N _B	N _A	S _B	S _A	L	M	S	L	M	S	dyn C	stat Co	grease	oil	bearing	kg
17	17	35	10	8	0,30	0,15	21,0	32,0	0,3	0,1					41	145	306	21,2	37,7	55,3	8,7	5,2	43 000		B7003C.2RSD.T.P4S.UL	0,040
	17	35	10	11	0,30	0,15	21,0	32,0	0,3	0,1					54	220	485	48,0	81,2	112,5	8,2	5,0	38 000		B7003E.2RSD.T.P4S.UL	0,040
	17	35	10	8	0,30	0,15	21,0	32,0	0,3	0,1					41	145	306	21,2	37,7	55,3	8,7	5,2	43 000	63 000	B7003C.T.P4S.UL	0,040
	17	35	10	11	0,30	0,15	21,0	32,0	0,3	0,1					54	220	485	48,0	81,2	112,5	8,2	5,0	38 000	56 000	B7003E.T.P4S.UL	0,040
	17	35	10	8	0,30	0,15	21,0	32,0	0,3	0,1					18	73	161	17,1	30,4	44,0	8,7	3,6	53 000	80 000	HCB7003C.T.P4S.UL	0,035
	17	35	10	11	0,30	0,15	21,0	32,0	0,3	0,1					28	105	250	43,1	69,0	96,2	8,2	3,5	45 000	67 000	HCB7003E.T.P4S.UL	0,035
	17	35	10	8	0,30	0,15	21,0	32,0	0,3	0,1					18	73	161	17,1	30,4	44,0	13,8	3,6	70 000	110 000	XCB7003C.T.P4S.UL	0,035
	17	35	10	11	0,30	0,15	21,0	32,0	0,3	0,1					28	105	250	43,1	69,0	96,2	13,2	3,5	60 000	90 000	XCB7003E.T.P4S.UL	0,035
	17	40	12	10	0,60	0,30	22,5	34,5	0,6	0,3					53	185	390	23,6	42,8	63,8	11,3	6,1	38 000		B7203C.2RSD.T.P4S.UL	0,060
	17	40	12	13	0,60	0,30	22,5	34,5	0,6	0,3					75	290	625	54,0	90,6	126,0	10,8	5,9	36 000		B7203E.2RSD.T.P4S.UL	0,060
	17	40	12	10	0,60	0,30	22,5	34,5	0,6	0,3					53	185	390	23,6	42,8	63,8	11,3	6,1	38 000	56 000	B7203C.T.P4S.UL	0,060
	17	40	12	13	0,60	0,30	22,5	34,5	0,6	0,3					75	290	625	54,0	90,6	126,0	10,8	5,9	36 000	53 000	B7203E.T.P4S.UL	0,060
	17	40	12	10	0,60	0,30	22,5	34,5	0,6	0,3					25	98	210	19,5	35,0	50,5	11,3	4,3	50 000	75 000	HCB7203C.T.P4S.UL	0,052
	17	40	12	13	0,60	0,30	22,5	34,5	0,6	0,3					28	141	328	42,5	77,5	107,4	10,8	4,2	43 000	63 000	HCB7203E.T.P4S.UL	0,052
	17	47	14	11	1,00	0,60	23,0	41,0	1,0	0,6					70	140	290	35,0	45,0	70,0	14,5	7,9	29 000	48 000	A7303C.T.P4S.UL	0,120
	17	47	14	14	1,00	0,60	23,0	41,0	1,0	0,6					120	250	490	80,0	100,0	140,0	13,9	7,6	26 000	43 000	A7303E.T.P4S.UL	0,120
20	20	37	9	8	0,30	0,30	22,0	33,5	0,3	0,1					38	135	298	24,3	43,6	66,0	8,6	5,1	38 000		B71904C.2RSD.T.P4S.UL	0,034
	20	37	9	11	0,30	0,30	22,0	33,5	0,3	0,1					41	172	391	47,0	84,1	118,3	8,2	4,9	36 000		B71904E.2RSD.T.P4S.UL	0,034
	20	37	9	8	0,30	0,30	22,0	33,5	0,3	0,1					38	135	298	24,3	43,6	66,0	8,6	5,1	38 000	56 000	B71904C.T.P4S.UL	0,034
	20	37	9	11	0,30	0,30	22,0	33,5	0,3	0,1					41	172	391	47,0	84,1	118,3	8,2	4,9	36 000	53 000	B71904E.T.P4S.UL	0,034
	20	37	9	8	0,30	0,30	22,0	33,5	0,3	0,1					13	59	130	16,9	32,0	47,3	8,6	3,6	50 000	75 000	HCB71904C.T.P4S.UL	0,030
	20	37	9	11	0,30	0,30	22,0	33,5	0,3	0,1					27	77	192	47,8	69,5	98,7	8,2	3,4	43 000	63 000	HCB71904E.T.P4S.UL	0,030
	20	37	9	8	0,30	0,30	22,0	33,5	0,3	0,1					13	59	130	16,9	32,0	47,3	13,8	3,6	63 000	95 000	XCB71904C.T.P4S.UL	0,030
	20	37	9	11	0,30	0,30	22,0	33,5	0,3	0,1					27	77	192	47,8	69,5	98,7	13,1	3,4	56 000	85 000	XCB71904E.T.P4S.UL	0,030
	20	42	12	10	0,60	0,30	25,0	37,0	0,6	0,3					52	180	378	22,7	40,0	58,9	11,0	7,0	36 000		B7004C.2RSD.T.P4S.UL	0,069
	20	42	12	13	0,60	0,30	25,0	37,0	0,6	0,3					71	277	599	51,6	86,6	119,2	10,5	6,7	32 000		B7004E.2RSD.T.P4S.UL	0,069
	20	42	12	10	0,60	0,30	25,0	37,0	0,6	0,3	1,5	2,2	1,4	6,6	52	180	378	22,7	40,0	58,9	11,0	7,0	36 000	53 000	B7004C.T.P4S.UL	0,069
	20	42	12	13	0,60	0,30	25,0	37,0	0,6	0,3	1,5	2,2	1,4	6,6	71	277	599	51,6	86,6	119,2	10,5	6,7	32 000	48 000	B7004E.T.P4S.UL	0,069
	20	42	12	10	0,60	0,30	25,0	37,0	0,6	0,3	1,5	2,2	1,4	6,6	24	92	202	18,8	33,0	47,3	11,0	4,9	45 000	67 000	HCB7004C.T.P4S.UL	0,062
	20	42	12	13	0,60	0,30	25,0	37,0	0,6	0,3	1,5	2,2	1,4	6,6	26	131	304	41,4	73,5	101,5	10,5	4,7	38 000	56 000	HCB7004E.T.P4S.UL	0,062
	20	42	12	10	0,60	0,30	25,0	37,0	0,6	0,3	1,5	2,2	1,4	6,6	24	92	202	18,8	33,0	47,3	17,7	4,9	60 000	90 000	XCB7004C.T.P4S.UL	0,062
	20	42	12	13	0,60	0,30	25,0	37,0	0,6	0,3	1,5	2,2	1,4	6,6	26	131	304	41,4	73,5	101,5	16,8	4,7	50 000	75 000	XCB7004E.T.P4S.UL	0,062

12. Measurement tables

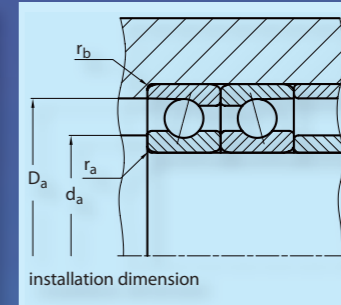
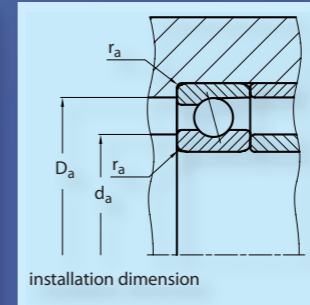
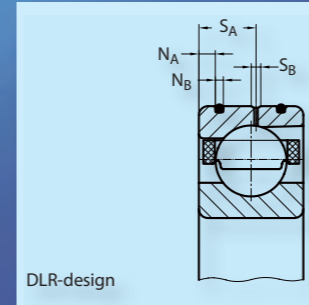
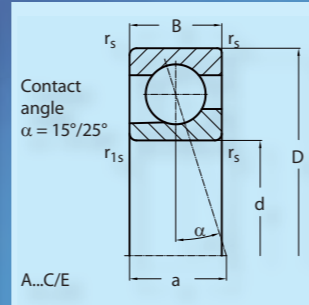
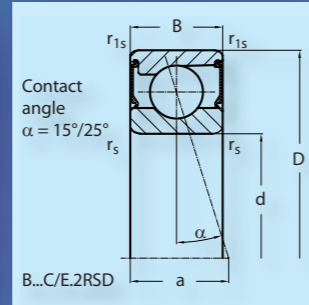
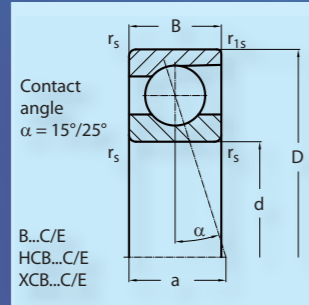

12. Measurement tables

Shaft	dimension (mm)						installation dimension (mm)				DLR-dimension (mm)				preload (N)			axial rigidity (N/μm)			load rating (kN)		speed limit (min ⁻¹)		Code	weight
	d	D	B	a	r _s min	r _{1s} min	d _a h12	D _a H12	r _a max	r _b max	N _B	N _A	S _B	S _A	L	M	S	L	M	S	dyn C	stat Co	grease	oil	bearing	kg
20	20	47	14	12	1,00	0,60	26,5	40,5	1,0	0,6					74	250	528	27,6	49,5	73,2	13,0	8,0	32 000		B7204C.2RSD.T.P4S.UL	0,108
	20	47	14	15	1,00	0,60	26,5	40,5	1,0	0,6					105	392	844	63,1	104,9	145,0	12,3	7,7	30 000		B7204E.2RSD.T.P4S.UL	0,108
	20	47	14	12	1,00	0,60	26,5	40,5	1,0	0,6					74	250	528	27,6	49,5	73,2	13,0	8,0	32 000	48 000	B7204C.T.P4S.UL	0,108
	20	47	14	15	1,00	0,60	26,5	40,5	1,0	0,6					105	392	844	63,1	104,9	145,0	12,3	7,7	30 000	45 000	B7204E.T.P4S.UL	0,108
	20	47	14	12	1,00	0,60	26,5	40,5	1,0	0,6					45	161	348	24,3	44,2	64,2	13,0	5,6	43 000	63 000	HCB7204C.T.P4S.UL	0,098
	20	47	14	15	1,00	0,60	26,5	40,5	1,0	0,6					56	240	540	57,0	98,0	134,5	12,3	5,4	36 000	53 000	HCB7204E.T.P4S.UL	0,098
	20	52	15	12	1,10	0,60	27,0	45,0	1,1	0,6					90	180	370	34,0	45,0	70,0	18,5	9,9	26 000	42 000	A7304C.T.P4S.UL	0,150
	20	52	15	16	1,10	0,60	27,0	45,0	1,1	0,6					160	310	630	80,0	110,0	140,0	17,9	9,6	23 000	38 000	A7304E.T.P4S.UL	0,150
25	25	42	9	9	0,30	0,30	27,0	38,5	0,3	0,1					39	140	325	27,1	48,5	75,5	9,0	5,8	32 000		B71905C.2RSD.T.P4S.UL	0,040
	25	42	9	12	0,30	0,30	27,0	38,5	0,3	0,1					41	188	429	54,4	98,0	137,8	8,5	5,5	30 000		B71905E.2RSD.T.P4S.UL	0,040
	25	42	9	9	0,30	0,30	27,0	38,5	0,3	0,1					39	140	325	27,1	48,5	75,5	9,0	5,8	32 000	48 000	B71905C.T.P4S.UL	0,040
	25	42	9	12	0,30	0,30	27,0	38,5	0,3	0,1					41	188	429	54,4	98,0	137,8	8,5	5,5	30 000	45 000	B71905E.T.P4S.UL	0,040
	25	42	9	9	0,30	0,30	27,0	38,5	0,3	0,1					13	63	148	19,2	37,3	55,0	9,0	4,0	43 000	63 000	HCB71905C.T.P4S.UL	0,035
	25	42	9	12	0,30	0,30	27,0	38,5	0,3	0,1					30	85	215	55,6	81,0	115,8	8,5	3,8	36 000	53 000	HCB71905E.T.P4S.UL	0,035
	25	42	9	9	0,30	0,30	27,0	38,5	0,3	0,1					13	63	148	19,2	37,3	55,0	14,4	4,0	53 000	80 000	XCB71905C.T.P4S.UL	0,035
	25	42	9	12	0,30	0,30	27,0	38,5	0,3	0,1					30	85	215	55,6	81,0	115,8	13,7	3,8	48 000	70 000	XCB71905E.T.P4S.UL	0,035
	25	47	12	11	0,60	0,30	30,0	42,0	0,6	0,3					74	255	534	29,8	51,9	75,5	12,5	7,7	30 000		B7005C.2RSD.T.P4S.UL	0,084
	25	47	12	14	0,60	0,30	30,0	42,0	0,6	0,3					100	382	830	67,7	112,0	153,5	11,9	7,4	28 000		B7005E.2RSD.T.P4S.UL	0,084
	25	47	12	11	0,60	0,30	30,0	42,0	0,6	0,3	1,5	2,2	1,4	6,6	74	255	534	29,8	51,9	75,5	12,5	7,7	30 000	45 000	B7005C.T.P4S.UL	0,084
	25	47	12	14	0,60	0,30	30,0	42,0	0,6	0,3	1,5	2,2	1,4	6,6	100	382	830	67,7	112,0	153,5	11,9	7,4	28 000	43 000	B7005E.T.P4S.UL	0,084
	25	47	12	11	0,60	0,30	30,0	42,0	0,6	0,3	1,5	2,2	1,4	6,6	33	131	280	24,5	42,5	60,5	12,5	5,4	38 000	56 000	HCB7005C.T.P4S.UL	0,073
	25	47	12	14	0,60	0,30	30,0	42,0	0,6	0,3	1,5	2,2	1,4	6,6	39	190	430	55,0	96,5	132,0	11,9	5,1	34 000	50 000	HCB7005E.T.P4S.UL	0,073
	25	47	12	11	0,60	0,30	30,0	42,0	0,6	0,3	1,5	2,2	1,4	6,6	33	131	280	24,5	42,5	60,5	20,1	5,4	50 000	75 000	XCB7005C.T.P4S.UL	0,073
	25	47	12	14	0,60	0,30	30,0	42,0	0,6	0,3	1,5	2,2	1,4	6,6	39	190	430	55,0	96,5	132,0	19,1	5,1	43 000	63 000	XCB7005E.T.P4S.UL	0,073
25	52	15	13	1,00	0,60	31,5	45,5	1,0	0,6					80	270	560	30,1	53,6	79,2	14,3	9,9	28 000		B7205C.2RSD.T.P4S.UL	0,133	
25	52	15	17	1,00	0,60	31,5	45,5	1,0	0,6					113	420	900	68,9	144,0	158,0	13,6	9,5	26 000		B7205E.2RSD.T.P4S.UL	0,133	
25	52	15	13	1,00	0,60	31,5	45,5	1,0	0,6					80	270	560	30,1	53,6	79,2	14,3	9,9	28 000	43 000	B7205C.T.P4S.UL	0,133	
25	52	15	17	1,00	0,60	31,5	45,5	1,0	0,6					113	420	900	68,9	144,0	158,0	13,6	9,5	26 000	40 000	B7205E.T.P4S.UL	0,133	
25	52	15	13	1,00	0,60	31,5	45,5	1,0	0,6					46	171	366	27,4	47,7	69,1	14,3	6,9	36 000	53 000	HCB7205C.T.P4S.UL	0,122	
25	52	15	17	1,00	0,60	31,5	45,5	1,0	0,6					58	250	562	61,5	105,0	145,0	13,6	6,6	32 000	48 000	HCB7205E.T.P4S.UL	0,122	
25	62	17	14	1,10	1,10	32,0	55,0	1,1	1,1					120	240	470	45,0	60,0	85,0	26,3	15,2	30 000	47 500	A7305C.T.P4S.UL	0,222	
25	62	17	19	1,10	1,10	32,0	55,0	1,1	1,1					200	400	800	100,0	130,0	180,0	25,5	14,8	26 500	43 000	A7305E.T.P4S.UL	0,222	

12. Measurement tables

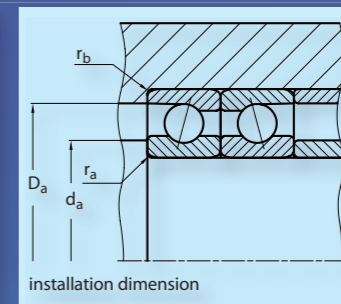
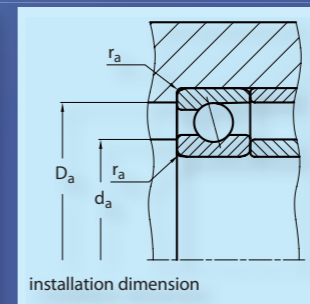
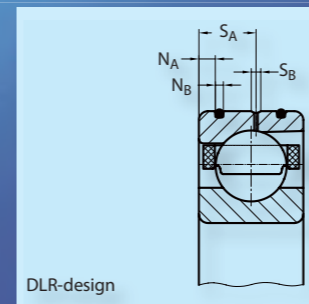
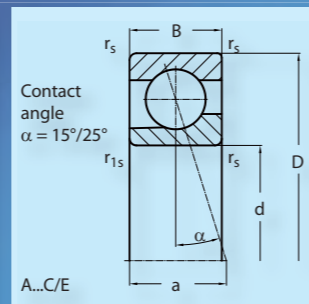
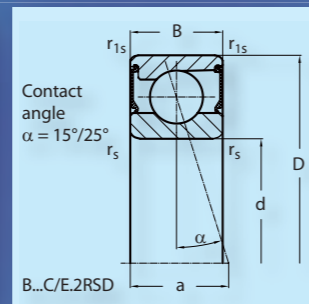
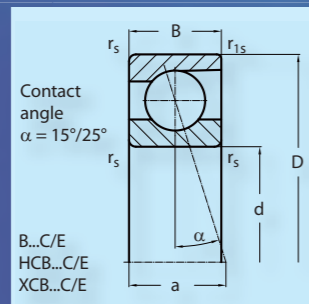

12. Measurement tables

Shaft	dimension (mm)						installation dimension (mm)				DLR-dimension (mm)				preload (N)			axial rigidity (N/μm)			load rating (kN)		speed limit (min ⁻¹)		Code	weight
	d	D	B	a	r _s min	r _{1s} min	d _a h12	D _a H12	r _a max	r _b max	N _B	N _A	S _B	S _A	L	M	S	L	M	S	dyn C	stat Co	grease	oil	bearing	kg
30	30	47	9	10	0,30	0,30	32,0	43,5	0,3	0,1					40	160	346	30,0	54,5	82,0	8,1	5,8	28 000		B71906C.2RSD.T.P4S.UL	0,046
	30	47	9	14	0,30	0,30	32,0	43,5	0,3	0,1					42	195	446	58,7	105,8	149,0	7,6	5,4	26 000		B71906E.2RSD.T.P4S.UL	0,046
	30	47	9	10	0,30	0,30	32,0	43,5	0,3	0,1					40	160	346	30,0	54,5	82,0	8,1	5,8	28 000	43 000	B71906C.T.P4S.UL	0,046
	30	47	9	14	0,30	0,30	32,0	43,5	0,3	0,1					42	195	446	58,7	105,8	149,0	7,6	5,4	26 000	40 000	B71906E.T.P4S.UL	0,046
	30	47	9	10	0,30	0,30	32,0	43,5	0,3	0,1					15	65	152	21,2	40,1	59,4	8,1	4,1	36 000	53 000	HCB71906C.T.P4S.UL	0,041
	30	47	9	14	0,30	0,30	32,0	43,5	0,3	0,1					30	85	224	60,0	87,8	126,0	7,6	3,8	32 000	48 000	HCB71906E.T.P4S.UL	0,041
	30	47	9	10	0,30	0,30	32,0	43,5	0,3	0,1					15	65	152	21,2	40,1	59,4	12,9	4,1	48 000	70 000	XCB71906C.T.P4S.UL	0,041
	30	47	9	14	0,30	0,30	32,0	43,5	0,3	0,1					30	85	224	60,0	87,8	126,0	12,2	3,8	40 000	60 000	XCB71906E.T.P4S.UL	0,041
	30	55	13	14	1,00	0,60	36,0	49,0	1,0	0,3					74	258	546	32,6	57,8	85,0	14,1	10,7	26 000		B7006C.2RSD.T.P4S.UL	0,117
	30	55	13	16	1,00	0,60	36,0	49,0	1,0	0,3					102	397	860	74,0	124,0	171,0	13,4	9,9	24 000		B7006E.2RSD.T.P4S.UL	0,117
	30	55	13	14	1,00	0,60	36,0	49,0	1,0	0,3	1,5	2,8	1,4	7,2	74	258	546	32,6	57,8	85,0	14,1	10,7	26 000	40 000	B7006C.T.P4S.UL	0,117
	30	55	13	16	1,00	0,60	36,0	49,0	1,0	0,3	1,5	2,8	1,4	7,2	102	397	860	74,0	124,0	171,0	13,4	9,9	24 000	38 000	B7006E.T.P4S.UL	0,117
	30	55	13	14	1,00	0,60	36,0	49,0	1,0	0,3	1,5	2,8	1,4	7,2	34	138	298	27,1	47,8	68,6	14,1	7,5	32 000	48 000	HCB7006C.T.P4S.UL	0,106
	30	55	13	16	1,00	0,60	36,0	49,0	1,0	0,3	1,5	2,8	1,4	7,2	38	194	445	59,0	106,0	146,5	13,4	6,9	28 000	43 000	HCB7006E.T.P4S.UL	0,106
	30	55	13	14	1,00	0,60	36,0	49,0	1,0	0,3	1,5	2,8	1,4	7,2	34	138	298	27,1	47,8	68,6	22,6	7,5	43 000	60 000	XCB7006C.T.P4S.UL	0,106
	30	55	13	16	1,00	0,60	36,0	49,0	1,0	0,3	1,5	2,8	1,4	7,2	38	194	445	59,0	106,0	146,5	21,4	6,9	36 000	53 000	XCB7006E.T.P4S.UL	0,106
	30	62	16	14	1,00	0,60	37,5	54,5	1,0	0,6					121	410	857	42,0	75,4	112,0	20,8	14,8	24 000		B7206C.2RSD.T.P4S.UL	0,204
	30	62	16	19	1,00	0,60	37,5	54,5	1,0	0,6					175	638	1360	95,0	157,1	218,0	19,8	14,1	22 000		B7206E.2RSD.T.P4S.UL	0,204
	30	62	16	14	1,00	0,60	37,5	54,5	1,0	0,6					121	410	857	42,0	75,4	112,0	20,8	14,8	24 000	38 000	B7206C.T.P4S.UL	0,204
	30	62	16	19	1,00	0,60	37,5	54,5	1,0	0,6					175	638	1360	95,0	157,1	218,0	19,8	14,1	22 000	36 000	B7206E.T.P4S.UL	0,204
30	62	16	14	1,00	0,60	37,5	54,5	1,0	0,6					74	270	568	38,5	67,5	98,5	20,8	10,4	30 000	45 000	HCB7206C.T.P4S.UL	0,183	
30	62	16	19	1,00	0,60	37,5	54,5	1,0	0,6					99	406	894	87,5	148,0	203,5	19,8	9,9	26 000	40 000	HCB7206E.T.P4S.UL	0,183	
30	72	19	16	1,10	1,10	37,0	65,0	1,1	1,1					160	320	640	50,0	70,0	100,0	32,1	20,0	25 500	40 500	A7306C.T.P4S.UL	0,329	
30	72	19	21	1,10	1,10	37,0	65,0	1,1	1,1					270	550	1090	120,0	160,0	210,0	31,0	19,4	23 000	37 000	A7306E.T.P4S.UL	0,329	
35	35	55	10	11	0,60	0,30	40,0	50,5	0,6	0,1					59	210	480	36,2	64,0	99,5	10,2	7,5	24 000		B71907C.2RSD.T.P4S.UL	0,076
	35	55	10	16	0,60	0,30	40,0	50,5	0,6	0,1					61	275	620	73,5	129,5	180,5	9,6	7,0	22 000		B71907E.2RSD.T.P4S.UL	0,076
	35	55	10	11	0,60	0,30	40,0	50,5	0,6	0,1					59	210	480	36,2	64,0	99,5	10,2	7,5	24 000	38 000	B71907C.T.P4S.UL	0,076
	35	55	10	16	0,60	0,30	40,0	50,5	0,6	0,1					61	275	620	73,5	129,5	180,5	9,6	7,0	22 000	36 000	B71907E.T.P4S.UL	0,076
	35	55	10	11	0,60	0,30	40,0	50,5	0,6	0,1					20	95	218	26,5	50,0	72,5	10,2	5,2	32 000	48 000	HCB71907C.T.P4S.UL	0,069
	35	55	10	16	0,60	0,30	40,0	50,5	0,6	0,1					44	128	315	74,0	109,0	154,0	9,6	4,9	26 000	40 000	HCB71907E.T.P4S.UL	0,069
	35	55	10	11	0,60	0,30	40,0	50,5	0,6	0,1					20	95	218	26,5	50,0	72,5	16,4	5,2	40 000	60 000	XCB71907C.T.P4S.UL	0,069
	35	55	10	16	0,60	0,30	40,0	50,5	0,6	0,1					44	128	315	74,0	109,0	154,0	15,4	4,9	34 000	50 000	XCB71907E.T.P4S.UL	0,069

12. Measurement tables

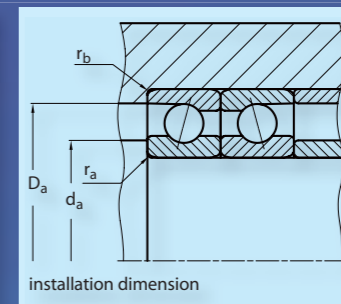
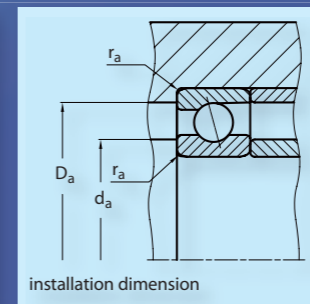
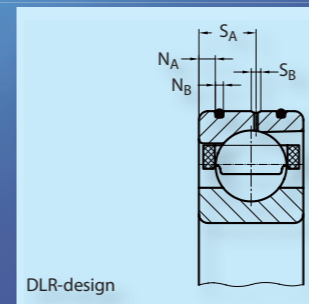
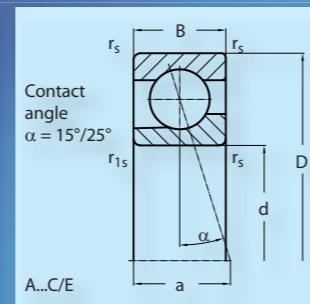
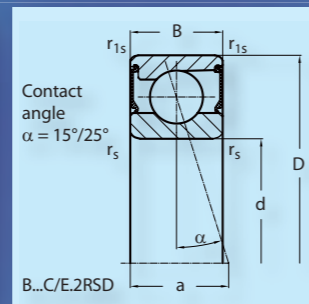
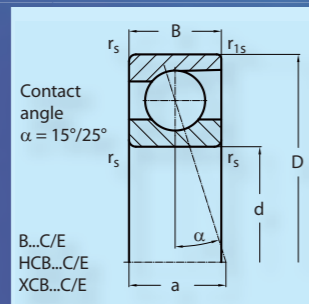

12. Measurement tables

Shaft	dimension (mm)						installation dimension (mm)				DLR-dimension (mm)				preload (N)			axial rigidity (N/μm)			load rating (kN)		speed limit (min ⁻¹)		Code	weight
	d	D	B	a	r _s min	r _{1s} min	d _a h12	D _a H12	r _a max	r _b max	N _B	N _A	S _B	S _A	L	M	S	L	M	S	dyn C	stat Co	grease	oil	bearing	kg
35	35	62	14	14	1,00	0,60	41,0	56,0	1,0	0,3					96	332	698	38,8	67,5	99,5	16,0	12,7	22 000		B7007C.2RSD.T.P4S.UL	0,157
	35	62	14	18	1,00	0,60	41,0	56,0	1,0	0,3					135	520	1118	88,2	147,0	202,0	15,1	11,8	20 000		B7007E.2RSD.T.P4S.UL	0,157
	35	62	14	14	1,00	0,60	41,0	56,0	1,0	0,3	1,5	2,8	1,4	8,0	96	332	698	38,8	67,5	99,5	16,0	12,7	22 000	36 000	B7007C.T.P4S.UL	0,157
	35	62	14	18	1,00	0,60	41,0	56,0	1,0	0,3	1,5	2,8	1,4	8,0	135	520	1118	88,2	147,0	202,0	15,1	11,8	20 000	34 000	B7007E.T.P4S.UL	0,157
	35	62	14	14	1,00	0,60	41,0	56,0	1,0	0,3	1,5	2,8	1,4	8,0	45	176	380	32,0	56,0	80,5	16,0	8,9	28 000	43 000	HCB7007C.T.P4S.UL	0,143
	35	62	14	18	1,00	0,60	41,0	56,0	1,0	0,3	1,5	2,8	1,4	8,0	55	254	580	72,5	126,0	173,0	15,1	8,2	24 000	38 000	HCB7007E.T.P4S.UL	0,143
	35	62	14	14	1,00	0,60	41,0	56,0	1,0	0,3	1,5	2,8	1,4	8,0	45	176	380	32,0	56,0	80,5	25,6	8,9	38 000	56 000	XCB7007C.T.P4S.UL	0,143
	35	62	14	18	1,00	0,60	41,0	56,0	1,0	0,3	1,5	2,8	1,4	8,0	55	254	580	72,5	126,0	173,0	24,1	8,2	32 000	48 000	XCB7007E.T.P4S.UL	0,143
	35	72	17	16	1,10	0,60	44,0	63,0	1,0	0,6					135	455	940	45,0	79,0	116,0	25,4	19,4	20 000		B7207C.2RSD.T.P4S.UL	0,296
	35	72	17	21	1,10	0,60	44,0	63,0	1,0	0,6					196	715	1520	103,0	170,0	234,0	24,1	18,5	19 000		B7207E.2RSD.T.P4S.UL	0,296
	35	72	17	16	1,10	0,60	44,0	63,0	1,0	0,6					135	455	940	45,0	79,0	116,0	25,4	19,4	20 000	34 000	B7207C.T.P4S.UL	0,296
	35	72	17	21	1,10	0,60	44,0	63,0	1,0	0,6					196	715	1520	103,0	170,0	234,0	24,1	18,5	19 000	32 000	B7207E.T.P4S.UL	0,296
	35	72	17	16	1,10	0,60	44,0	63,0	1,0	0,6					65	240	512	38,0	65,0	93,5	25,4	13,6	26 000	40 000	HCB7207C.T.P4S.UL	0,267
	35	72	17	21	1,10	0,60	44,0	63,0	1,0	0,6					85	360	805	87,0	148,0	202,0	24,1	13,0	22 000	36 000	HCB7207E.T.P4S.UL	0,267
	35	80	21	18	1,50	1,10	43,0	72,0	1,5	1,1					200	400	810	60,0	85,0	120,0	40,3	26,6	22 000	36 000	A7307C.T.P4S.UL	0,428
	35	80	21	24	1,50	1,10	43,0	72,0	1,5	1,1					340	680	1370	140,0	180,0	250,0	38,8	25,0	21 000	32 500	A7307E.T.P4S.UL	0,428
40	40	62	12	13	0,60	0,30	45,0	57,5	0,6	0,1					84	300	632	41,0	73,0	107,5	16,0	13,0	22 000		B71908C.2RSD.T.P4S.UL	0,105
	40	62	12	18	0,60	0,30	45,0	57,5	0,6	0,1					112	450	985	92,0	155,0	215,0	15,1	12,3	20 000		B71908E.2RSD.T.P4S.UL	0,105
	40	62	12	13	0,60	0,30	45,0	57,5	0,6	0,1	1,5	2,2	1,6	6,6	84	300	632	41,0	73,0	107,5	16,0	13,0	22 000	36 000	B71908C.T.P4S.UL	0,105
	40	62	12	18	0,60	0,30	45,0	57,5	0,6	0,1	1,5	2,2	1,6	6,6	112	450	985	92,0	155,0	215,0	15,1	12,3	20 000	34 000	B71908E.T.P4S.UL	0,105
	40	62	12	13	0,60	0,30	45,0	57,5	0,6	0,1	1,5	2,2	1,6	6,6	39	155	340	34,0	60,0	86,1	16,0	9,1	28 000	43 000	HCB71908C.T.P4S.UL	0,089
	40	62	12	18	0,60	0,30	45,0	57,5	0,6	0,1	1,5	2,2	1,6	6,6	75	222	520	90,8	134,0	185,0	15,1	8,6	24 000	38 000	HCB71908E.T.P4S.UL	0,089
	40	62	12	13	0,60	0,30	45,0	57,5	0,6	0,1	1,5	2,2	1,6	6,6	39	155	340	34,0	60,0	86,1	25,6	9,1	36 000	53 000	XCB71908C.T.P4S.UL	0,089
	40	62	12	18	0,60	0,30	45,0	57,5	0,6	0,1	1,5	2,2	1,6	6,6	75	222	520	90,8	134,0	185,0	24,2	8,6	30 000	45 000	XCB71908E.T.P4S.UL	0,089
	40	68	15	15	1,00	0,60	46,0	62,0	1,0	0,3					101	354	744	44,0	77,0	113,2	16,9	14,0	20 000		B7008C.2RSD.T.P4S.UL	0,196
	40	68	15	20	1,00	0,60	46,0	62,0	1,0	0,3					142	546	1180	99,0	166,0	228,5	15,9	13,0	19 000		B7008E.2RSD.T.P4S.UL	0,196
	40	68	15	15	1,00	0,60	46,0	62,0	1,0	0,3	1,5	2,8	1,4	8,5	101	354	744	44,0	77,0	113,2	16,9	14,0	20 000	34 000	B7008C.T.P4S.UL	0,196
	40	68	15	20	1,00	0,60	46,0	62,0	1,0	0,3	1,5	2,8	1,4	8,5	142	546	1180	99,0	166,0	228,5	15,9	13,0	19 000	32 000	B7008E.T.P4S.UL	0,196
	40	68	15	15	1,00	0,60	46,0	62,0	1,0	0,3	1,5	2,8	1,4	8,5	48	188	405	36,0	63,5	91,0	16,9	9,8	26 000	40 000	HCB7008C.T.P4S.UL	0,180
	40	68	15	20	1,00	0,60	46,0	62,0	1,0	0,3	1,5	2,8	1,4	8,5	55	270	618	80,0	142,5	196,0	15,9	9,1	22 000	36 000	HCB7008E.T.P4S.UL	0,180
	40	68	15	15	1,00	0,60	46,0	62,0	1,0	0,3	1,5	2,8	1,4	8,5	48	188	405	36,0	63,5	91,0	27,0	9,8	34 000	50 000	XCB7008C.T.P4S.UL	0,180
	40	68	15	20	1,00	0,60	46,0	62,0	1,0	0,3	1,5	2,8	1,4	8,5	55	270	618	80,0	142,5	196,0	25,5	9,1	28 000	43 000	XCB7008E.T.P4S.UL	0,180

12. Measurement tables

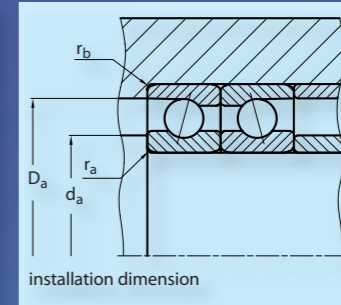
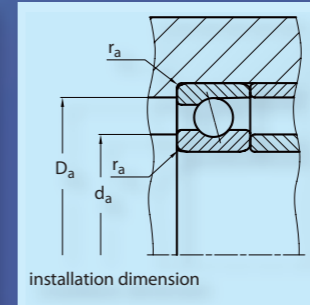
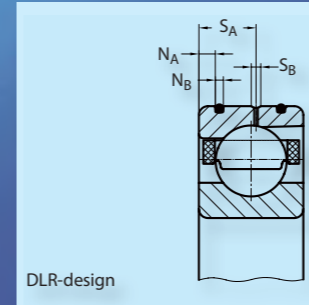
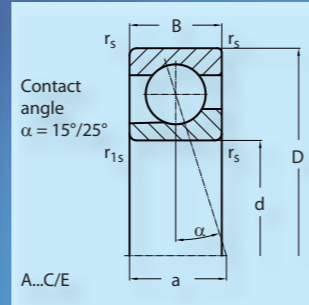
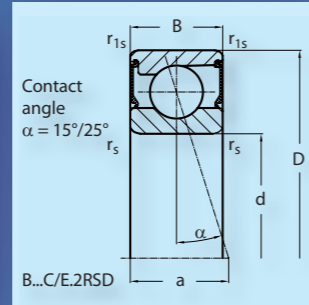
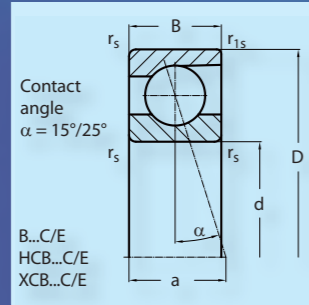

12. Measurement tables

Shaft	dimension (mm)						installation dimension (mm)				DLR-dimension (mm)				preload (N)			axial rigidity (N/μm)			load rating (kN)		speed limit (min ⁻¹)		Code	weight
	d	D	B	a	r _s min	r _{1s} min	d _a h12	D _a H12	r _a max	r _b max	N _B	N _A	S _B	S _A	L	M	S	L	M	S	dyn C	stat Co	grease	oil	bearing	kg
40	40	80	18	17	1,10	1,10	48,0	72,0	1,0	1,0					175	585	1205	47,0	86,5	126,5	35,0	25,3	18 000		B7208C.2RSD.T.P4S.UL	0,364
	40	80	18	23	1,10	1,10	48,0	72,0	1,0	1,0					259	910	1925	114,0	186,0	254,0	33,3	24,2	17 000		B7208E.2RSD.T.P4S.UL	0,364
	40	80	18	17	1,10	1,10	48,0	72,0	1,0	1,0					175	585	1205	47,0	86,5	126,5	35,0	25,3	18 000	30 000	B7208C.T.P4S.UL	0,364
	40	80	18	23	1,10	1,10	48,0	72,0	1,0	1,0					259	910	1925	114,0	186,0	254,0	33,3	24,2	17 000	28 000	B7208E.T.P4S.UL	0,364
	40	80	18	17	1,10	1,10	48,0	72,0	1,0	1,0					89	315	660	42,0	71,5	102,0	35,0	17,7	24 000	38 000	HCB7208C.T.P4S.UL	0,315
	40	80	18	23	1,10	1,10	48,0	72,0	1,0	1,0					117	478	1045	97,5	162,5	220,0	33,3	17,0	20 000	34 000	HCB7208E.T.P4S.UL	0,315
	40	90	23	20	1,50	1,50	48,0	82,0	1,5	1,5					240	470	950	65,0	90,0	130,0	47,7	32,5	21 000	32 500	A7308C.T.P4S.UL	0,622
	40	90	23	27	1,50	1,50	48,0	82,0	1,5	1,5					400	810	1610	150,0	200,0	260,0	45,7	31,1	18 500	29 000	A7308E.T.P4S.UL	0,622
45	45	68	12	14	0,60	0,30	50,0	63,5	0,6	0,1					89	316	666	44,2	79,0	116,0	16,8	14,7	19 000		B71909C.2RSD.T.P4S.UL	0,126
	45	68	12	19	0,60	0,30	50,0	63,5	0,6	0,1					115	472	1040	99,0	169,0	233,5	15,9	13,7	18 000		B71909E.2RSD.T.P4S.UL	0,126
	45	68	12	14	0,60	0,30	50,0	63,5	0,6	0,1	1,5	2,8	1,6	6,6	89	316	666	44,2	79,0	116,0	16,8	14,7	19 000	32 000	B71909C.T.P4S.UL	0,126
	45	68	12	19	0,60	0,30	50,0	63,5	0,6	0,1	1,5	2,8	1,6	6,6	115	472	1040	99,0	169,0	233,5	15,9	13,7	18 000	30 000	B71909E.T.P4S.UL	0,126
	45	68	12	14	0,60	0,30	50,0	63,5	0,6	0,1	1,5	2,8	1,6	6,6	41	164	360	36,5	65,0	93,5	16,8	10,3	24 000	38 000	HCB71909C.T.P4S.UL	0,108
	45	68	12	19	0,60	0,30	50,0	63,5	0,6	0,1	1,5	2,8	1,6	6,6	79	230	540	98,0	145,0	201,0	15,9	9,6	22 000	36 000	HCB71909E.T.P4S.UL	0,108
	45	68	12	14	0,60	0,30	50,0	63,5	0,6	0,1	1,5	2,8	1,6	6,6	41	164	360	36,5	65,0	93,5	26,9	10,3	32 000	48 000	XCB71909C.T.P4S.UL	0,108
	45	68	12	19	0,60	0,30	50,0	63,5	0,6	0,1	1,5	2,8	1,6	6,6	79	230	540	98,0	145,0	201,0	25,4	9,6	28 000	43 000	XCB71909E.T.P4S.UL	0,108
	45	75	16	16	1,00	0,60	51,0	69,0	1,0	0,3					144	490	1020	50,0	88,0	128,5	22,8	19,6	18 000		B7009C.2RSD.T.P4S.UL	0,236
	45	75	16	22	1,00	0,60	51,0	69,0	1,0	0,3					210	768	1640	115,0	190,0	260,0	21,5	18,2	17 000		B7009E.2RSD.T.P4S.UL	0,236
	45	75	16	16	1,00	0,60	51,0	69,0	1,0	0,3	1,5	3,4	1,4	9,3	144	490	1020	50,0	88,0	128,5	22,8	19,6	18 000	30 000	B7009C.T.P4S.UL	0,236
	45	75	16	22	1,00	0,60	51,0	69,0	1,0	0,3	1,5	3,4	1,4	9,3	210	768	1640	115,0	190,0	260,0	21,5	18,2	17 000	28 000	B7009E.T.P4S.UL	0,236
	45	75	16	16	1,00	0,60	51,0	69,0	1,0	0,3	1,5	3,4	1,4	9,3	72	265	560	42,0	73,0	104,0	22,8	13,7	24 000	38 000	HCB7009C.T.P4S.UL	0,211
	45	75	16	22	1,00	0,60	51,0	69,0	1,0	0,3	1,5	3,4	1,4	9,3	90	394	876	97,0	165,0	226,0	21,5	12,7	20 000	34 000	HCB7009E.T.P4S.UL	0,211
	45	75	16	16	1,00	0,60	51,0	69,0	1,0	0,3	1,5	3,4	1,4	9,3	72	265	560	42,0	73,0	104,0	36,5	13,7	30 000	45 000	XCB7009C.T.P4S.UL	0,211
	45	75	16	22	1,00	0,60	51,0	69,0	1,0	0,3	1,5	3,4	1,4	9,3	90	394	876	97,0	165,0	226,0	34,5	12,7	26 000	40 000	XCB7009E.T.P4S.UL	0,211
	45	85	19	18	1,10	1,10	52,5	78,0	1,0	1,0					185	605	1250	53,0	91,0	134,0	41,0	30,6	17 000		B7209C.2RSD.T.P4S.UL	0,408
	45	85	19	25	1,10	1,10	52,5	78,0	1,0	1,0					270	955	2016	121,6	197,3	270,0	39,0	29,3	15 000		B7209E.2RSD.T.P4S.UL	0,408
	45	85	19	18	1,10	1,10	52,5	78,0	1,0	1,0					185	605	1250	53,0	91,0	134,0	41,0	30,6	17 000	28 000	B7209C.T.P4S.UL	0,408
	45	85	19	25	1,10	1,10	52,5	78,0	1,0	1,0					270	955	2016	121,6	197,3	270,0	39,0	29,3	15 000	24 000	B7209E.T.P4S.UL	0,408
45	85	19	18	1,10	1,10	52,5	78,0	1,0	1,0					92	330	695	45,0	76,0	108,0	41,0	21,4	22 000	36 000	HCB7209C.T.P4S.UL	0,344	
45	85	19	25	1,10	1,10	52,5	78,0	1,0	1,0					120	494	1080	103,0	172,0	234,0	39,0	20,5	18 000	30 000	HCB7209E.T.P4S.UL	0,344	
45	100	25	22	1,50	1,50	54,0	91,0	1,5	1,5					290	580	1150	75,0	100,0	140,0	57,6	40,2	18 500	29 000	A7309C.T.P4S.UL	0,829	
45	100	25	29	1,50	1,50	54,0	91,0	1,5	1,5					490	980	1950	170,0	220,0	300,0	55,2	38,4	16 000	23 000	A7309E.T.P4S.UL	0,829	

12. Measurement tables

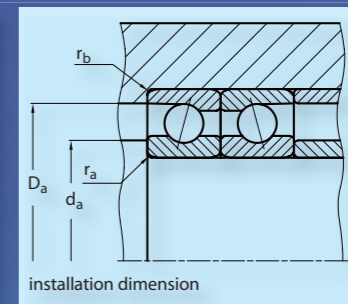
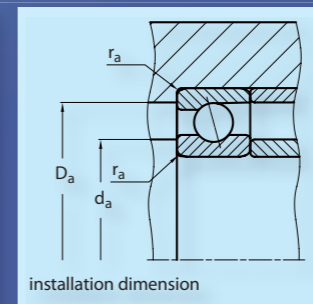
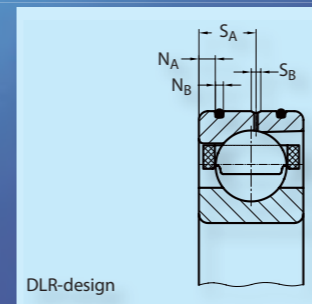
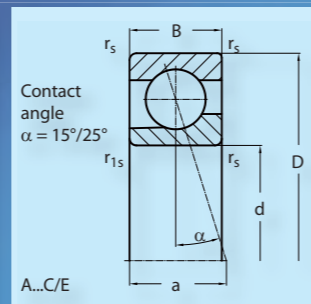
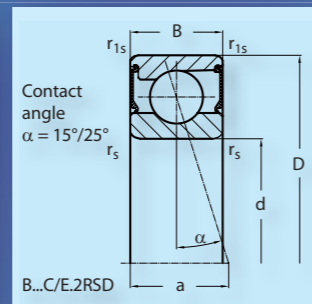
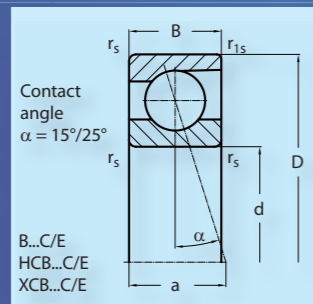

12. Measurement tables

Shaft	dimension (mm)						installation dimension (mm)				DLR-dimension (mm)				preload (N)			axial rigidity (N/μm)			load rating (kN)		speed limit (min ⁻¹)		Code	weight
	d	D	B	a	r _s min	r _{1s} min	d _a h12	D _a H12	r _a max	r _b max	N _B	N _A	S _B	S _A	L	M	S	L	M	S	dyn C	stat Co	grease	oil	bearing	kg
50	50	72	12	14	0,60	0,30	55,0	67,5	0,6	0,1					90	320	680	46,0	81,5	120,0	17,1	15,3	18 000		B71910C.2RSD.T.P4S.UL	0,129
	50	72	12	20	0,60	0,30	55,0	67,5	0,6	0,1					117	480	1060	103,0	175,0	242,0	16,1	14,2	16 000		B71910E.2RSD.T.P4S.UL	0,129
	50	72	12	14	0,60	0,30	55,0	67,5	0,6	0,1	1,5	2,8	1,6	6,6	90	320	680	46,0	81,5	120,0	17,1	15,3	18 000	30 000	B71910C.T.P4S.UL	0,129
	50	72	12	20	0,60	0,30	55,0	67,5	0,6	0,1	1,5	2,8	1,6	6,6	117	480	1060	103,0	175,0	242,0	16,1	14,2	16 000	26 000	B71910E.T.P4S.UL	0,129
	50	72	12	14	0,60	0,30	55,0	67,5	0,6	0,1	1,5	2,8	1,6	6,6	40	164	364	38,0	67,0	96,5	17,1	10,7	22 000	36 000	HCB71910C.T.P4S.UL	0,110
	50	72	12	20	0,60	0,30	55,0	67,5	0,6	0,1	1,5	2,8	1,6	6,6	79	233	550	101,0	150,0	208,0	16,1	10,0	20 000	34 000	HCB71910E.T.P4S.UL	0,110
	50	72	12	14	0,60	0,30	55,0	67,5	0,6	0,1	1,5	2,8	1,6	6,6	40	164	364	38,0	67,0	96,5	27,3	10,7	30 000	43 000	XCB71910C.T.P4S.UL	0,110
	50	72	12	20	0,60	0,30	55,0	67,5	0,6	0,1	1,5	2,8	1,6	6,6	79	233	550	101,0	150,0	208,0	25,7	10,0	26 000	40 000	XCB71910E.T.P4S.UL	0,110
	50	80	16	17	1,00	0,60	56,0	74,0	1,0	0,3					150	505	1050	52,0	92,0	135,0	28,2	25,5	17 000		B7010C.2RSD.T.P4S.UL	0,262
	50	80	16	23	1,00	0,60	56,0	74,0	1,0	0,3					210	780	1665	120,0	199,0	272,0	26,6	22,8	15 000		B7010E.2RSD.T.P4S.UL	0,262
	50	80	16	17	1,00	0,60	56,0	74,0	1,0	0,3	1,5	3,4	1,4	9,3	150	505	1050	52,0	92,0	135,0	28,2	25,5	17 000	28 000	B7010C.T.P4S.UL	0,262
	50	80	16	23	1,00	0,60	56,0	74,0	1,0	0,3	1,5	3,4	1,4	9,3	210	780	1665	120,0	199,0	272,0	26,6	22,8	15 000	24 000	B7010E.T.P4S.UL	0,262
	50	80	16	17	1,00	0,60	56,0	74,0	1,0	0,3	1,5	3,4	1,4	9,3	75	275	588	45,0	77,0	110,0	28,2	17,2	22 000	36 000	HCB7010C.T.P4S.UL	0,226
	50	80	16	23	1,00	0,60	56,0	74,0	1,0	0,3	1,5	3,4	1,4	9,3	88	396	890	100,0	172,0	236,0	26,6	15,9	18 000	30 000	HCB7010E.T.P4S.UL	0,226
	50	80	16	17	1,00	0,60	56,0	74,0	1,0	0,3	1,5	3,4	1,4	9,3	75	275	588	45,0	77,0	110,0	45,1	17,2	28 000	43 000	XCB7010C.T.P4S.UL	0,226
	50	80	16	23	1,00	0,60	56,0	74,0	1,0	0,3	1,5	3,4	1,4	9,3	88	396	890	100,0	172,0	236,0	42,6	15,9	24 000	38 000	XCB7010E.T.P4S.UL	0,226
50	90	20	19	1,10	1,10	57,0	83,0	1,0	1,0					242	790	1630	60,0	105,0	153,0	44,6	36,1	16 000		B7210C.2RSD.T.P4S.UL	0,459	
50	90	20	26	1,10	1,10	57,0	83,0	1,0	1,0					350	1220	2580	138,0	222,0	305,0	42,3	34,5	14 000		B7210E.2RSD.T.P4S.UL	0,459	
50	90	20	19	1,10	1,10	57,0	83,0	1,0	1,0	1,5	4,0	1,6	11,2	242	790	1630	60,0	105,0	153,0	44,6	36,1	16 000	26 000	B7210C.T.P4S.UL	0,459	
50	90	20	26	1,10	1,10	57,0	83,0	1,0	1,0	1,5	4,0	1,6	11,2	350	1220	2580	138,0	222,0	305,0	42,3	34,5	14 000	22 000	B7210E.T.P4S.UL	0,459	
50	90	20	19	1,10	1,10	57,0	83,0	1,0	1,0	1,5	4,0	1,6	11,2	122	423	895	51,0	85,0	123,0	44,6	25,3	20 000	34 000	HCB7210C.T.P4S.UL	0,385	
50	90	20	26	1,10	1,10	57,0	83,0	1,0	1,0	1,5	4,0	1,6	11,2	168	655	1420	120,0	199,0	267,0	42,3	24,1	17 000	28 000	HCB7210E.T.P4S.UL	0,385	
50	110	27	24	2,00	2,00	60,0	100,0	2,0	2,0					350	700	1400	75,0	110,0	150,0	69,7	47,8	16 000	26 500	A7310C.T.P4S.UL	1,07	
50	110	27	32	2,00	2,00	60,0	100,0	2,0	2,0					590	1190	2380	180,0	240,0	320,0	66,9	45,7	15 000	23 000	A7310E.T.P4S.UL	1,07	
55	55	80	13	16	1,00	0,60	60,0	75,5	0,6	0,3					110	390	820	51,0	90,0	132,0	20,9	18,8	16 000		B71911C.2RSD.T.P4S.UL	0,176
	55	80	13	22	1,00	0,60	60,0	75,5	0,6	0,3					150	595	1290	114,0	195,0	265,0	19,7	17,5	15 000		B71911E.2RSD.T.P4S.UL	0,176
	55	80	13	16	1,00	0,60	60,0	75,5	0,6	0,3	1,5	2,8	1,6	7,2	110	390	820	51,0	90,0	132,0	20,9	18,8	16 000	26 000	B71911C.T.P4S.UL	0,176
	55	80	13	22	1,00	0,60	60,0	75,5	0,6	0,3	1,5	2,8	1,6	7,2	150	595	1290	114,0	195,0	265,0	19,7	17,5	15 000	24 000	B71911E.T.P4S.UL	0,176
	55	80	13	16	1,00	0,60	60,0	75,5	0,6	0,3	1,5	2,8	1,6	7,2	50	202	442	42,0	74,2	106,0	20,9	13,1	20 000	34 000	HCB71911C.T.P4S.UL	0,151
	55	80	13	22	1,00	0,60	60,0	75,5	0,6	0,3	1,5	2,8	1,6	7,2	58	296	692	94,0	169,0	233,0	19,7	12,2	18 000	30 000	HCB71911E.T.P4S.UL	0,151
	55	80	13	16	1,00	0,60	60,0	75,5	0,6	0,3	1,5	2,8	1,6	7,2	50	202	442	42,0	74,2	106,0	33,5	13,1	26 000	40 000	XCB71911C.T.P4S.UL	0,151
	55	80	13	22	1,00	0,60	60,0	75,5	0,6	0,3	1,5	2,8	1,6	7,2	58	296	692	94,0	169,0	233,0	31,5	12,2	24 000	38 000	XCB71911E.T.P4S.UL	0,151

12. Measurement tables

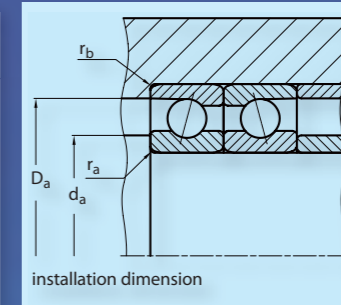
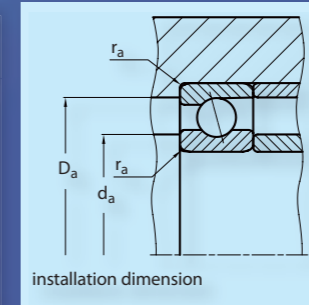
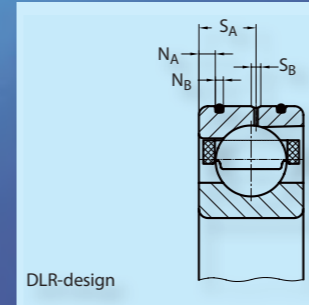
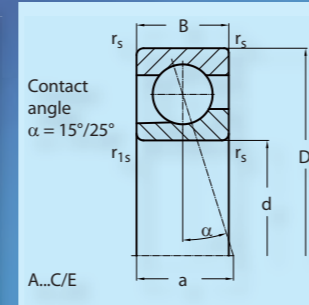
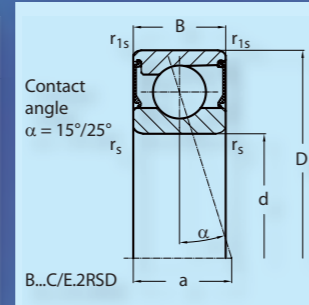
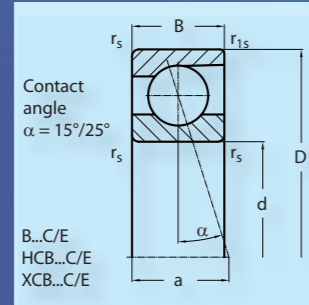

12. Measurement tables

Shaft	dimension (mm)						installation dimension (mm)				DLR-dimension (mm)				preload (N)			axial rigidity (N/μm)			load rating (kN)		speed limit (min ⁻¹)		Code	weight
	d	D	B	a	r _s min	r _{1s} min	d _a h12	D _a H12	r _a max	r _b max	N _B	N _A	S _B	S _A	L	M	S	L	M	S	dyn C	stat Co	grease	oil	bearing	kg
55	55	90	18	19	1,10	1,00	62,0	83,0	1,0	0,6					205	680	1425	62,0	107,0	155,0	36,8	33,4	15 000		B7011C.2RSD.T.P4S.UL	0,383
	55	90	18	26	1,10	1,00	62,0	83,0	1,0	0,6					298	1065	2260	141,0	230,0	318,0	34,7	31,0	14 000		B7011E.2RSD.T.P4S.UL	0,383
	55	90	18	19	1,10	1,00	62,0	83,0	1,0	0,6	1,5	4,3	1,4	9,7	205	680	1425	62,0	107,0	155,0	36,8	33,4	15 000	24 000	B7011C.T.P4S.UL	0,383
	55	90	18	26	1,10	1,00	62,0	83,0	1,0	0,6	1,5	4,3	1,4	9,7	298	1065	2260	141,0	230,0	318,0	34,7	31,0	14 000	22 000	B7011E.T.P4S.UL	0,383
	55	90	18	19	1,10	1,00	62,0	83,0	1,0	0,6	1,5	4,3	1,4	9,7	102	370	785	52,0	90,0	128,0	36,8	23,4	19 000	32 000	HCB7011C.T.P4S.UL	0,335
	55	90	18	26	1,10	1,00	62,0	83,0	1,0	0,6	1,5	4,3	1,4	9,7	135	550	1220	120,0	203,0	277,0	34,7	21,7	17 000	28 000	HCB7011E.T.P4S.UL	0,335
	55	90	18	19	1,10	1,00	62,0	83,0	1,0	0,6	1,5	4,3	1,4	9,7	102	370	785	52,0	90,0	128,0	58,9	23,4	26 000	40 000	XCB7011C.T.P4S.UL	0,335
	55	90	18	26	1,10	1,00	62,0	83,0	1,0	0,6	1,5	4,3	1,4	9,7	135	550	1220	120,0	203,0	277,0	55,6	21,7	22 000	36 000	XCB7011E.T.P4S.UL	0,335
	55	100	21	21	1,50	1,10	63,0	92,0	1,5	1,1					260	850	1750	66,0	114,0	166,0	53,0	42,7	14 000		B7211C.2RSD.T.P4S.UL	0,608
	55	100	21	29	1,50	1,10	63,0	92,0	1,5	1,1					380	1330	2795	155,0	252,0	342,0	50,3	40,8	13 000		B7211E.2RSD.T.P4S.UL	0,608
	55	100	21	21	1,50	1,10	63,0	92,0	1,5	1,1	1,8	3,8	1,6	12,0	260	850	1750	66,0	114,0	166,0	53,0	42,7	14 000	22 000	B7211C.T.P4S.UL	0,608
	55	100	21	29	1,50	1,10	63,0	92,0	1,5	1,1	1,8	3,8	1,6	12,0	380	1330	2795	155,0	252,0	342,0	50,3	40,8	13 000	20 000	B7211E.T.P4S.UL	0,608
	55	100	21	21	1,50	1,10	63,0	92,0	1,5	1,1	1,8	3,8	1,6	12,0	135	462	980	58,0	97,0	138,0	53,0	29,9	18 000	30 000	HCB7211C.T.P4S.UL	0,509
	55	100	21	29	1,50	1,10	63,0	92,0	1,5	1,1	1,8	3,8	1,6	12,0	178	700	1530	135,0	220,0	296,0	50,3	28,6	15 000	24 000	HCB7211E.T.P4S.UL	0,509
	55	120	29	26	2,00	2,00	65,0	110,0	2,0	2,0					370	740	1490	85,0	120,0	170,0	74,3	54,1	15 000	24 500	A7311C.T.P4S.UL	1,36
	55	120	29	35	2,00	2,00	65,0	110,0	2,0	2,0					630	1260	2520	200,0	260,0	340,0	71,0	51,5	14 000	22 000	A7311E.T.P4S.UL	1,36
60	60	85	13	16	1,00	0,60	65,0	80,5	0,6	0,3					116	410	868	55,0	95,0	140,1	22,6	20,4	15 000		B71912C.2RSD.T.P4S.UL	0,190
	60	85	13	23	1,00	0,60	65,0	80,5	0,6	0,3					156	622	1353	124,4	209,2	387,9	21,3	19,0	14 000		B71912E.2RSD.T.P4S.UL	0,190
	60	85	13	16	1,00	0,60	65,0	80,5	0,6	0,3	1,5	2,8	1,6	7,2	116	410	868	55,0	95,0	140,1	22,6	20,4	15 000	24 000	B71912C.T.P4S.UL	0,190
	60	85	13	23	1,00	0,60	65,0	80,5	0,6	0,3	1,5	2,8	1,6	7,2	156	622	1353	124,4	209,2	387,9	21,3	19,0	14 000	22 000	B71912E.T.P4S.UL	0,190
	60	85	13	16	1,00	0,60	65,0	80,5	0,6	0,3	1,5	2,8	1,6	7,2	54	214	470	44,8	80,1	114,0	22,6	14,3	19 000	32 000	HCB71912C.T.P4S.UL	0,162
	60	85	13	23	1,00	0,60	65,0	80,5	0,6	0,3	1,5	2,8	1,6	7,2	56	300	705	98,0	180,0	247,9	21,3	13,3	17 000	28 000	HCB71912E.T.P4S.UL	0,162
	60	85	13	16	1,00	0,60	65,0	80,5	0,6	0,3	1,5	2,8	1,6	7,2	54	214	470	44,8	80,1	114,0	36,2	14,3	26 000	40 000	XCB71912C.T.P4S.UL	0,162
	60	85	13	23	1,00	0,60	65,0	80,5	0,6	0,3	1,5	2,8	1,6	7,2	56	300	705	98,0	180,0	247,9	34,0	13,3	22 000	36 000	XCB71912E.T.P4S.UL	0,162
	60	95	18	19	1,10	1,00	67,0	88,0	1,0	0,6					209	705	1460	64,7	112,0	162,5	37,6	34,9	14 000		B7012C.2RSD.T.P4S.UL	0,410
	60	95	18	27	1,10	1,00	67,0	88,0	1,0	0,6					300	1077	2280	148,0	240,0	330,0	35,4	32,4	13 000		B7012E.2RSD.T.P4S.UL	0,410
	60	95	18	19	1,10	1,00	67,0	88,0	1,0	0,6	1,5	3,8	1,6	10,4	209	705	1460	64,7	112,0	162,5	37,6	34,9	14 000	22 000	B7012C.T.P4S.UL	0,410
	60	95	18	27	1,10	1,00	67,0	88,0	1,0	0,6	1,5	3,8	1,6	10,4	300	1077	2280	148,0	240,0	330,0	35,4	32,4	13 000	20 000	B7012E.T.P4S.UL	0,410
	60	95	18	19	1,10	1,00	67,0	88,0	1,0	0,6	1,5	3,8	1,6	10,4	105	380	800	55,1	93,0	132,0	37,6	24,4	18 000	30 000	HCB7012C.T.P4S.UL	0,359
	60	95	18	27	1,10	1,00	67,0	88,0	1,0	0,6	1,5	3,8	1,6	10,4	136	570	1265	127,0	213,4	287,0	35,4	22,7	15 000	24 000	HCB7012E.T.P4S.UL	0,359
	60	95	18	19	1,10	1,00	67,0	88,0	1,0	0,6	1,5	3,8	1,6	10,4	105	380	800	55,1	93,0	132,0	60,2	24,4	24 000	38 000	XCB7012C.T.P4S.UL	0,359
	60	95	18	27	1,10	1,00	67,0	88,0	1,0	0,6	1,5	3,8	1,6	10,4	136	570	1265	127,0	213,4	287,0	56,7	22,7	20 000	34 000	XCB7012E.T.P4S.UL	0,359

12. Measurement tables

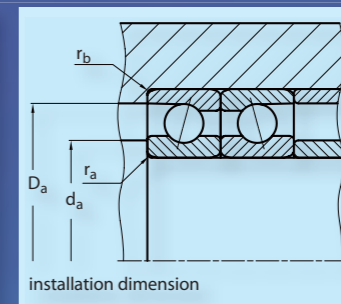
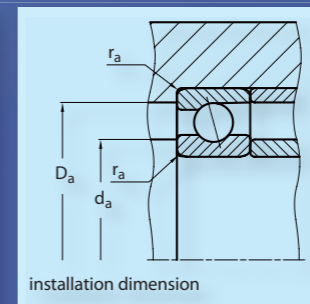
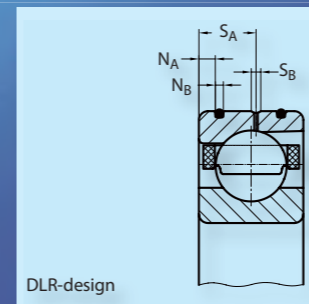
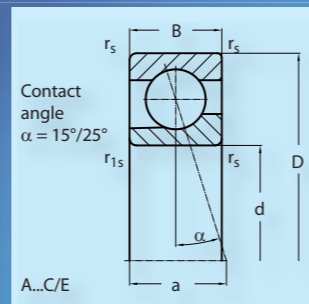
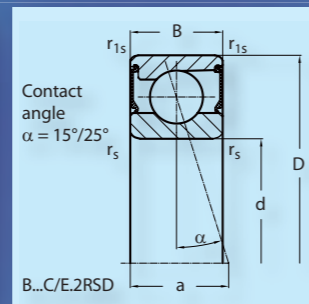
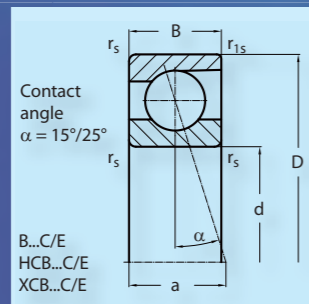

12. Measurement tables

Shaft	dimension (mm)						installation dimension (mm)				DLR-dimension (mm)				preload (N)			axial rigidity (N/μm)			load rating (kN)		speed limit (min ⁻¹)		Code	weight
	d	D	B	a	r _s min	r _{1s} min	d _a h12	D _a H12	r _a max	r _b max	N _B	N _A	S _B	S _A	L	M	S	L	M	S	dyn C	stat Co	grease	oil	bearing	kg
60	60	110	22	23	1,50	1,50	69,5	101,5	1,5	1,5					313	1020	2100	71,3	123,0	179,1	64,2	52,8	13 000		B7212C.2RSD.T.P4S.UL	0,782
	60	110	22	31	1,50	1,50	69,5	101,5	1,5	1,5					466	1600	3335	166,0	266,1	360,0	61,0	50,5	12 000		B7212E.2RSD.T.P4S.UL	0,782
	60	110	22	23	1,50	1,50	69,5	101,5	1,5	1,5					313	1020	2100	71,3	123,0	179,1	64,2	52,8	13 000	20 000	B7212C.T.P4S.UL	0,782
	60	110	22	31	1,50	1,50	69,5	101,5	1,5	1,5					466	1600	3335	166,0	266,1	360,0	61,0	50,5	12 000	19 000	B7212E.T.P4S.UL	0,782
	60	110	22	23	1,50	1,50	69,5	101,5	1,5	1,5					160	560	1160	61,1	102,3	145,0	64,2	37,0	16 000	26 000	HCB7212C.T.P4S.UL	0,646
	60	110	22	31	1,50	1,50	69,5	101,5	1,5	1,5					230	865	1863	144,9	235,7	319,0	61,0	35,4	14 000	22 000	HCB7212E.T.P4S.UL	0,646
	60	130	31	28	2,10	2,10	71,0	119,0	2,1	2,1					420	850	1690	95,0	130,0	190,0	84,6	64,7	14 000	22 000	A7312C.T.P4S.UL	1,75
	60	130	31	38	2,10	2,10	71,0	119,0	2,1	2,1					720	1430	2870	220,0	290,0	390,0	80,9	61,6	12 500	19 500	A7312E.T.P4S.UL	1,75
65	65	90	13	17	1,00	0,60	70,0	85,5	0,6	0,3					120	420	880	56,7	99,0	146,1	22,9	21,1	14 000		B71913C.2RSD.T.P4S.UL	0,202
	65	90	13	25	1,00	0,60	70,0	85,5	0,6	0,3					152	620	1350	127,5	215,0	295,0	21,5	19,6	13 000		B71913E.2RSD.T.P4S.UL	0,202
	65	90	13	17	1,00	0,60	70,0	85,5	0,6	0,3	1,5	2,8	1,6	7,2	120	420	880	56,7	99,0	146,1	22,9	21,1	14 000	22 000	B71913C.T.P4S.UL	0,202
	65	90	13	25	1,00	0,60	70,0	85,5	0,6	0,3	1,5	2,8	1,6	7,2	152	620	1350	127,5	215,0	295,0	21,5	19,6	13 000	20 000	B71913E.T.P4S.UL	0,202
	65	90	13	17	1,00	0,60	70,0	85,5	0,6	0,3	1,5	2,8	1,6	7,2	55	220	480	46,9	82,4	118,0	22,9	14,8	18 000	30 000	HCB71913C.T.P4S.UL	0,173
	65	90	13	25	1,00	0,60	70,0	85,5	0,6	0,3	1,5	2,8	1,6	7,2	57	308	720	101,0	185,0	257,0	21,5	13,7	15 000	24 000	HCB71913E.T.P4S.UL	0,173
	65	90	13	17	1,00	0,60	70,0	85,5	0,6	0,3	1,5	2,8	1,6	7,2	55	220	480	46,9	82,4	118,0	36,6	14,8	24 000	38 000	XCB71913C.T.P4S.UL	0,173
	65	90	13	25	1,00	0,60	70,0	85,5	0,6	0,3	1,5	2,8	1,6	7,2	57	308	720	101,0	185,0	257,0	34,3	13,7	20 000	34 000	XCB71913E.T.P4S.UL	0,173
	65	100	18	20	1,10	1,00	72,0	93,0	1,0	0,6					215	720	1490	67,2	115,0	169,0	38,3	36,4	13 000		B7013C.2RSD.T.P4S.UL	0,435
	65	100	18	28	1,10	1,00	72,0	93,0	1,0	0,6					310	1120	2375	155,4	254,0	344,0	36,1	33,8	12 000		B7013E.2RSD.T.P4S.UL	0,435
	65	100	18	20	1,10	1,00	72,0	93,0	1,0	0,6	1,8	4,0	1,6	10,4	215	720	1490	67,2	115,0	169,0	38,3	36,4	13 000	20 000	B7013C.T.P4S.UL	0,435
	65	100	18	28	1,10	1,00	72,0	93,0	1,0	0,6	1,8	4,0	1,6	10,4	310	1120	2375	155,4	254,0	344,0	36,1	33,8	12 000	19 000	B7013E.T.P4S.UL	0,435
	65	100	18	20	1,10	1,00	72,0	93,0	1,0	0,6	1,8	4,0	1,6	10,4	110	390	830	57,2	97,0	138,6	38,3	25,5	17 000	28 000	HCB7013C.T.P4S.UL	0,382
	65	100	18	28	1,10	1,00	72,0	93,0	1,0	0,6	1,8	4,0	1,6	10,4	136	580	1280	131,5	220,0	300,0	36,1	23,7	15 000	24 000	HCB7013E.T.P4S.UL	0,382
	65	100	18	20	1,10	1,00	72,0	93,0	1,0	0,6	1,8	4,0	1,6	10,4	110	390	830	57,2	97,0	138,6	61,3	25,5	22 000	36 000	XCB7013C.T.P4S.UL	0,382
	65	100	18	28	1,10	1,00	72,0	93,0	1,0	0,6	1,8	4,0	1,6	10,4	136	580	1280	131,5	220,0	300,0	57,7	23,7	19 000	32 000	XCB7013E.T.P4S.UL	0,382
65	120	23	24	1,50	1,50	75,5	109,5	1,5	1,5					325	1050	2160	75,0	128,8	187,0	66,7	57,9	12 000		B7213C.2RSD.T.P4S.UL	0,997	
65	120	23	33	1,50	1,50	75,5	109,5	1,5	1,5					482	1660	3460	175,0	280,1	380,0	63,1	55,2	11 000		B7213E.2RSD.T.P4S.UL	0,997	
65	120	23	24	1,50	1,50	75,5	109,5	1,5	1,5					325	1050	2160	75,0	128,8	187,0	66,7	57,9	12 000	19 000	B7213C.T.P4S.UL	0,997	
65	120	23	33	1,50	1,50	75,5	109,5	1,5	1,5					482	1660	3460	175,0	280,1	380,0	63,1	55,2	11 000	18 000	B7213E.T.P4S.UL	0,997	
65	120	23	24	1,50	1,50	75,5	109,5	1,5	1,5					170	582	1215	65,0	108,0	153,0	66,7	40,5	15 000	24 000	HCB7213C.T.P4S.UL	0,852	
65	120	23	33	1,50	1,50	75,5	109,5	1,5	1,5					232	890	1920	153,6	249,0	335,0	63,1	38,7	13 000	20 000	HCB7213E.T.P4S.UL	0,852	
70	70	100	16	19	1,00	0,60	76,0	94,5	0,6	0,3					170	585	1230	66,7	115,0	168,0	31,7	29,6	13 000		B71914C.2RSD.T.P4S.UL	0,331
	70	100	16	28	1,00	0,60	76,0	94,5	0,6	0,3					232	890	1920	152,0	252,0	340,0	29,8	27,5	12 000		B71914E.2RSD.T.P4S.UL	0,331
	70	100	16	19	1,00	0,60	76,0	94,5	0,6	0,3	1,8	3,1	1,6	9,3	170	585	1230	66,7	115,0	168,0	31,7	29,6	13 000	20 000	B71914C.T.P4S.UL	0,331
	70	100	16	28	1,00	0,60	76,0	94,5	0,6	0,3	1,8	3,1	1,6	9,3	232	890	1920	152,0	252,0	340,0	29,8	27,5	12 000	19 000	B71914E.T.P4S.UL	0,331

12. Measurement tables

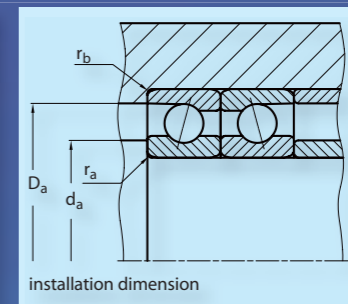
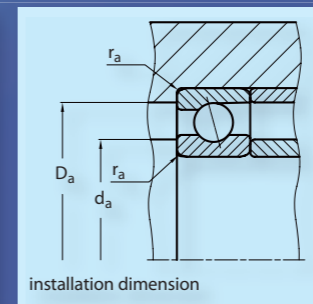
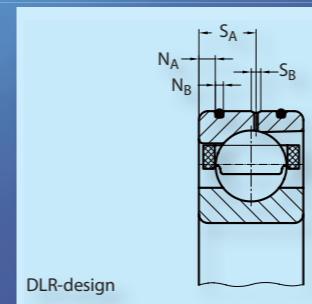
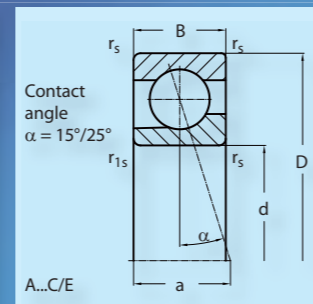
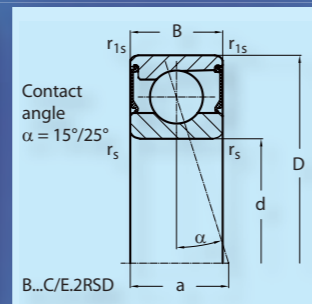
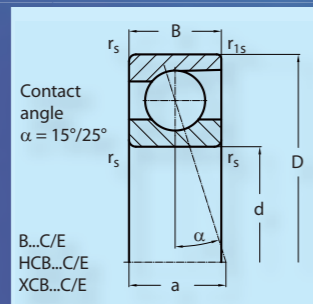

12. Measurement tables

Shaft	dimension (mm)						installation dimension (mm)				DLR-dimension (mm)				preload (N)			axial rigidity (N/μm)			load rating (kN)		speed limit (min ⁻¹)		Code	weight
	d	D	B	a	r _s min	r _{1s} min	d _a h12	D _a H12	r _a max	r _b max	N _B	N _A	S _B	S _A	L	M	S	L	M	S	dyn C	stat Co	grease	oil	bearing	kg
70	70	100	16	19	1,00	0,60	76,0	94,5	0,6	0,3	1,8	3,1	1,6	9,3	82	310	670	55,9	96,0	137,0	31,7	20,7	16 000	26 000	HCB71914C.T.P4S.UL	0,283
	70	100	16	28	1,00	0,60	76,0	94,5	0,6	0,3	1,8	3,1	1,6	9,3	95	450	1030	126,0	218,0	300,0	29,8	19,3	14 000	22 000	HCB71914E.T.P4S.UL	0,283
	70	100	16	19	1,00	0,60	76,0	94,5	0,6	0,3	1,8	3,1	1,6	9,3	82	310	670	55,9	96,0	137,0	50,8	20,7	22 000	36 000	XCB71914C.T.P4S.UL	0,283
	70	100	16	28	1,00	0,60	76,0	94,5	0,6	0,3	1,8	3,1	1,6	9,3	95	450	1030	126,0	218,0	300,0	47,7	19,3	18 000	30 000	XCB71914E.T.P4S.UL	0,283
	70	110	20	22	1,10	1,00	77,0	102,0	1,0	0,6					275	910	1890	74,0	127,1	185,0	47,8	47,3	12 000		B7014C.2RSD.T.P4S.UL	0,590
	70	110	20	31	1,10	1,00	77,0	102,0	1,0	0,6					400	1400	2950	172,0	274,0	373,5	45,0	44,0	11 000		B7014E.2RSD.T.P4S.UL	0,590
	70	110	20	22	1,10	1,00	77,0	102,0	1,0	0,6	1,8	4,0	1,6	11,6	275	910	1890	74,0	127,1	185,0	47,8	47,3	12 000	19 000	B7014C.T.P4S.UL	0,590
	70	110	20	31	1,10	1,00	77,0	102,0	1,0	0,6	1,8	4,0	1,6	11,6	400	1400	2950	172,0	274,0	373,5	45,0	44,0	11 000	18 000	B7014E.T.P4S.UL	0,590
	70	110	20	22	1,10	1,00	77,0	102,0	1,0	0,6	1,8	4,0	1,6	11,6	140	490	1040	63,0	106,0	150,0	47,8	33,1	16 000	26 000	HCB7014C.T.P4S.UL	0,504
	70	110	20	31	1,10	1,00	77,0	102,0	1,0	0,6	1,8	4,0	1,6	11,6	185	740	1610	147,0	242,0	326,0	45,0	30,8	13 000	20 000	HCB7014E.T.P4S.UL	0,504
	70	110	20	22	1,10	1,00	77,0	102,0	1,0	0,6	1,8	4,0	1,6	11,6	140	490	1040	63,0	106,0	150,0	76,4	33,1	20 000	34 000	XCB7014C.T.P4S.UL	0,504
	70	110	20	31	1,10	1,00	77,0	102,0	1,0	0,6	1,8	4,0	1,6	11,6	185	740	1610	147,0	242,0	326,0	72,0	30,8	17 000	28 000	XCB7014E.T.P4S.UL	0,504
	70	125	24	25	1,50	1,50	80,0	115,0	1,5	1,5					402	1300	2660	84,0	143,6	208,0	66,3	58,9	11 000	18 000	B7214C.T.P4S.UL	1,08
	70	125	24	35	1,50	1,50	80,0	115,0	1,5	1,5					600	2040	4240	195,0	310,0	422,0	62,7	56,2	10 000	17 000	B7214E.T.P4S.UL	1,08
	70	125	24	25	1,50	1,50	80,0	115,0	1,5	1,5					207	709	1480	72,0	120,0	170,0	66,3	41,2	14 000	22 000	HCB7214C.T.P4S.UL	0,925
	70	125	24	35	1,50	1,50	80,0	115,0	1,5	1,5					293	1100	2350	171,5	276,5	371,0	62,7	39,3	12 000	19 000	HCB7214E.T.P4S.UL	0,925
75	75	105	16	20	1,00	0,60	81,0	99,5	0,6	0,3					172	594	1244	68,3	118,4	172,3	31,3	29,4	12 000		B71915C.2RSD.T.P4S.UL	0,351
	75	105	16	29	1,00	0,60	81,0	99,5	0,6	0,3					234	900	1940	156,0	258,1	353,0	29,3	27,4	11 000		B71915E.2RSD.T.P4S.UL	0,351
	75	105	16	20	1,00	0,60	81,0	99,5	0,6	0,3	1,8	3,1	1,6	9,3	172	594	1244	68,3	118,4	172,3	31,3	29,4	12 000	19 000	B71915C.T.P4S.UL	0,351
	75	105	16	29	1,00	0,60	81,0	99,5	0,6	0,3	1,8	3,1	1,6	9,3	234	900	1940	156,0	258,1	353,0	29,3	27,4	11 000	18 000	B71915E.T.P4S.UL	0,351
	75	105	16	20	1,00	0,60	81,0	99,5	0,6	0,3	1,8	3,1	1,6	9,3	84	320	690	57,9	99,4	141,5	31,3	20,6	16 000	26 000	HCB71915C.T.P4S.UL	0,303
	75	105	16	29	1,00	0,60	81,0	99,5	0,6	0,3	1,8	3,1	1,6	9,3	96	455	1040	129,2	226,0	307,9	29,3	19,2	13 000	20 000	HCB71915E.T.P4S.UL	0,303
	75	105	16	20	1,00	0,60	81,0	99,5	0,6	0,3	1,8	3,1	1,6	9,3	84	320	690	57,9	99,4	141,5	50,0	20,6	20 000	34 000	XCB71915C.T.P4S.UL	0,303
	75	105	16	29	1,00	0,60	81,0	99,5	0,6	0,3	1,8	3,1	1,6	9,3	96	455	1040	129,2	226,0	307,9	47,0	19,2	17 000	28 000	XCB71915E.T.P4S.UL	0,303
	75	115	20	23	1,10	1,00	82,0	107,0	1,0	0,6					280	930	1925	76,6	132,0	192,0	48,7	49,2	12 000		B7015C.2RSD.T.P4S.UL	0,620
	75	115	20	32	1,10	1,00	82,0	107,0	1,0	0,6					405	1440	3030	177,5	288,0	390,0	45,8	45,7	11 000		B7015E.2RSD.T.P4S.UL	0,620
	75	115	20	23	1,10	1,00	82,0	107,0	1,0	0,6	1,8	4,0	1,6	11,6	280	930	1925	76,6	132,0	192,0	48,7	49,2	12 000	19 000	B7015C.T.P4S.UL	0,620
	75	115	20	32	1,10	1,00	82,0	107,0	1,0	0,6	1,8	4,0	1,6	11,6	405	1440	3030	177,5	288,0	390,0	45,8	45,7	11 000	18 000	B7015E.T.P4S.UL	0,620
	75	115	20	23	1,10	1,00	82,0	107,0	1,0	0,6	1,8	4,0	1,6	11,6	142	508	1070	66,1	111,0	157,0	48,7	34,4	15 000	24 000	HCB7015C.T.P4S.UL	0,530
	75	115	20	32	1,10	1,00	82,0	107,0	1,0	0,6	1,8	4,0	1,6	11,6	192	760	1670	154,0	254,0	343,0	45,8	32,0	13 000	20 000	HCB7015E.T.P4S.UL	0,530
	75	115	20	23	1,10	1,00	82,0	107,0	1,0	0,6	1,8	4,0	1,6	11,6	142	508	1070	66,1	111,0	157,0	77,8	34,4	19 000	32 000	XCB7015C.T.P4S.UL	0,530
	75	115	20	32	1,10	1,00	82,0	107,0	1,0	0,6	1,8	4,0	1,6	11,6	192	760	1670	154,0	254,0	343,0	73,3	32,0	16 000	26 000	XCB7015E.T.P4S.UL	0,530

12. Measurement tables

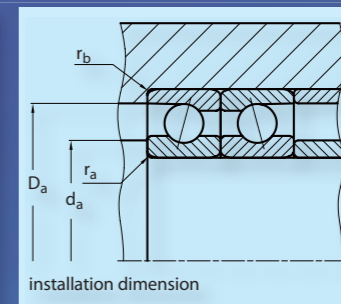
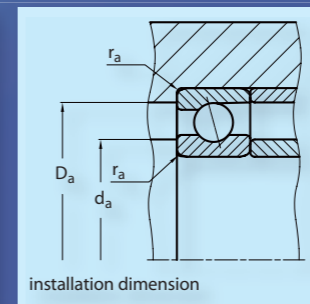
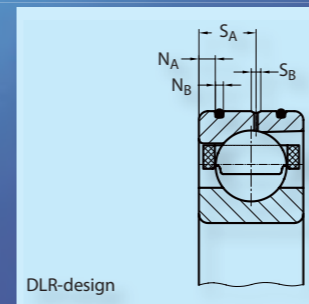
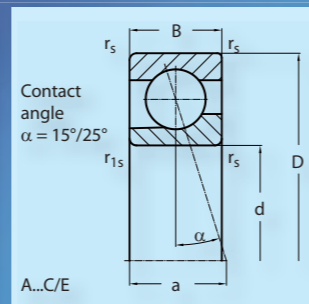
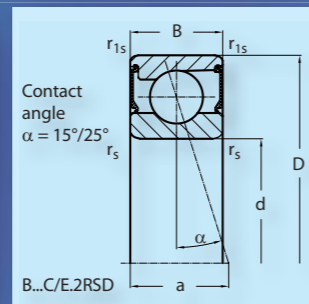
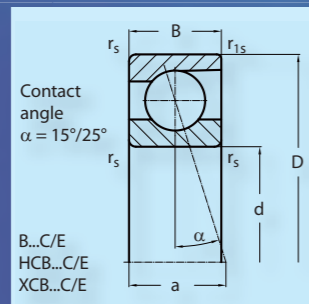

12. Measurement tables

Shaft	dimension (mm)						installation dimension (mm)				DLR-dimension (mm)				preload (N)			axial rigidity (N/μm)			load rating (kN)		speed limit (min ⁻¹)		Code	weight
	d	D	B	a	r _s min	r _{1s} min	d _a h12	D _a H12	r _a max	r _b max	N _B	N _A	S _B	S _A	L	M	S	L	M	S	dyn C	stat Co	grease	oil	bearing	kg
75	75	130	25	26	1,50	1,50	85,0	120,0	1,5	1,5					415	1345	2760	87,6	150,0	217,0	80,0	71,9	11 000	18 000	B7215C.T.P4S.UL	1,18
	75	130	25	36	1,50	1,50	85,0	120,0	1,5	1,5					620	2100	4390	205,0	325,0	441,9	75,8	68,5	9 500	16 000	B7215E.T.P4S.UL	1,18
	75	130	25	26	1,50	1,50	85,0	120,0	1,5	1,5					215	735	1530	75,0	126,0	177,5	80,0	50,3	14 000	22 000	HCB7215C.T.P4S.UL	0,987
	75	130	25	36	1,50	1,50	85,0	120,0	1,5	1,5					305	1140	2440	180,2	291,0	389,0	75,8	48,0	12 000	19 000	HCB7215E.T.P4S.UL	0,987
80	80	110	16	21	1,00	0,60	86,0	104,0	0,6	0,3					174	600	1260	70,1	120,0	175,0	32,5	31,7	12 000		B71916C.2RSD.T.P4S.UL	0,370
	80	110	16	30	1,00	0,60	86,0	104,0	0,6	0,3					236	910	1970	160,6	260,0	365,0	30,5	29,6	11 000		B71916E.2RSD.T.P4S.UL	0,370
	80	110	16	21	1,00	0,60	86,0	104,0	0,6	0,3	1,8	3,1	1,6	9,3	174	600	1260	70,1	120,0	175,0	32,5	31,7	12 000	19 000	B71916C.T.P4S.UL	0,370
	80	110	16	30	1,00	0,60	86,0	104,0	0,6	0,3	1,8	3,1	1,6	9,3	236	910	1970	160,6	260,0	365,0	30,5	29,6	11 000	18 000	B71916E.T.P4S.UL	0,370
	80	110	16	21	1,00	0,60	86,0	104,0	0,6	0,3	1,8	3,1	1,6	9,3	83	320	690	58,5	102,0	144,8	32,5	22,2	15 000	24 000	HCB71916C.T.P4S.UL	0,318
	80	110	16	30	1,00	0,60	86,0	104,0	0,6	0,3	1,8	3,1	1,6	9,3	95	460	1050	133,0	233,0	318,1	30,5	20,7	13 000	20 000	HCB71916E.T.P4S.UL	0,318
	80	110	16	21	1,00	0,60	86,0	104,0	0,6	0,3	1,8	3,1	1,6	9,3	83	320	690	58,5	102,0	144,8	52,0	22,2	19 000	32 000	XCB71916C.T.P4S.UL	0,318
	80	110	16	30	1,00	0,60	86,0	104,0	0,6	0,3	1,8	3,1	1,6	9,3	95	460	1050	133,0	233,0	318,1	48,8	20,7	16 000	26 000	XCB71916E.T.P4S.UL	0,318
	80	125	22	25	1,10	1,00	88,0	117,0	1,0	0,6					355	1160	2390	86,1	148,0	214,0	58,1	58,3	11 000		B7016C.2RSD.T.P4S.UL	0,857
	80	125	22	35	1,10	1,00	88,0	117,0	1,0	0,6					530	1830	3830	200,0	322,0	440,0	54,7	54,2	9 500		B7016E.2RSD.T.P4S.UL	0,857
	80	125	22	25	1,10	1,00	88,0	117,0	1,0	0,6	1,8	4,7	2,6	12,2	355	1160	2390	86,1	148,0	214,0	58,1	58,3	11 000	18 000	B7016C.T.P4S.UL	0,857
	80	125	22	35	1,10	1,00	88,0	117,0	1,0	0,6	1,8	4,7	2,6	12,2	530	1830	3830	200,0	322,0	440,0	54,7	54,2	9 500	16 000	B7016E.T.P4S.UL	0,857
80	125	22	25	1,10	1,00	88,0	117,0	1,0	0,6	1,8	4,7	2,6	12,2	185	640	1350	73,9	125,0	176,0	58,1	40,8	14 000	22 000	HCB7016C.T.P4S.UL	0,738	
80	125	22	35	1,10	1,00	88,0	117,0	1,0	0,6	1,8	4,7	2,6	12,2	250	970	2090	175,0	285,1	383,9	54,7	37,9	12 000	19 000	HCB7016E.T.P4S.UL	0,738	
80	125	22	25	1,10	1,00	88,0	117,0	1,0	0,6	1,8	4,7	2,6	12,2	185	640	1350	73,9	125,0	176,0	92,9	40,8	18 000	30 000	XCB7016C.T.P4S.UL	0,738	
80	125	22	35	1,10	1,00	88,0	117,0	1,0	0,6	1,8	4,7	2,6	12,2	250	970	2090	175,0	285,1	383,9	87,5	37,9	15 000	24 000	XCB7016E.T.P4S.UL	0,738	
80	140	26	28	2,00	2,00	91,0	129,0	2,0	2,0					555	1760	3600	95,2	162,0	234,0	92,1	82,3	10 000	17 000	B7216C.T.P4S.UL	1,45	
80	140	26	39	2,00	2,00	91,0	129,0	2,0	2,0					840	2780	5750	221,9	351,0	475,0	87,3	78,5	9 000	15 000	B7216E.T.P4S.UL	1,45	
80	140	26	28	2,00	2,00	91,0	129,0	2,0	2,0					290	960	1995	82,0	135,1	190,0	92,1	57,6	12 000	19 000	HCB7216C.T.P4S.UL	1,20	
80	140	26	39	2,00	2,00	91,0	129,0	2,0	2,0					420	1515	3200	196,0	312,0	416,0	87,3	55,0	11 000	18 000	HCB7216E.T.P4S.UL	1,20	
85	85	120	18	23	1,10	1,00	92,0	114,0	0,6	0,6					240	806	1675	80,1	138,0	200,0	41,9	43,3	11 000		B71917C.2RSD.T.P4S.UL	0,536
	85	120	18	33	1,10	1,00	92,0	114,0	0,6	0,6					335	1230	2630	184,9	300,0	410,0	39,4	40,3	9 500		B71917E.2RSD.T.P4S.UL	0,536
	85	120	18	23	1,10	1,00	92,0	114,0	0,6	0,6	1,8	4,0	2,2	10,4	240	806	1675	80,1	138,0	200,0	41,9	43,3	11 000	18 000	B71917C.T.P4S.UL	0,536
	85	120	18	33	1,10	1,00	92,0	114,0	0,6	0,6	1,8	4,0	2,2	10,4	335	1230	2630	184,9	300,0	410,0	39,4	40,3	9 500	16 000	B71917E.T.P4S.UL	0,536
	85	120	18	23	1,10	1,00	92,0	114,0	0,6	0,6	1,8	4,0	2,2	10,4	120	440	935	68,3	116,1	165,0	41,9	30,3	13 000	20 000	HCB71917C.T.P4S.UL	0,460
	85	120	18	33	1,10	1,00	92,0	114,0	0,6	0,6	1,8	4,0	2,2	10,4	148	640	1440	158,0	266,5	362,0	39,4	28,2	12 000	19 000	HCB71917E.T.P4S.UL	0,460
	85	120	18	23	1,10	1,00	92,0	114,0	0,6	0,6	1,8	4,0	2,2	10,4	120	440	935	68,3	116,1	165,0	67,0	30,3	18 000	30 000	XCB71917C.T.P4S.UL	0,460
	85	120	18	33	1,10	1,00	92,0	114,0	0,6	0,6	1,8	4,0	2,2	10,4	148	640	1440	158,0	266,5	362,0	63,0	28,2	15 000	24 000	XCB71917E.T.P4S.UL	0,460

12. Measurement tables

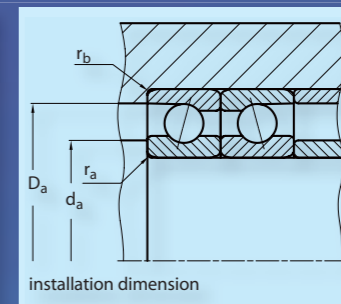
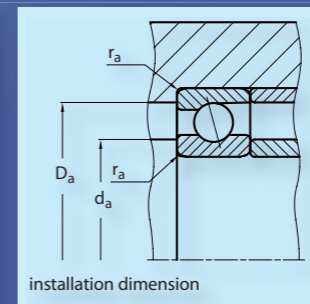
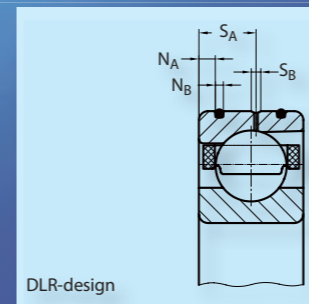
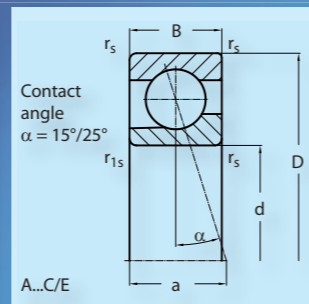
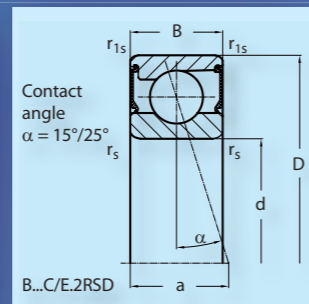
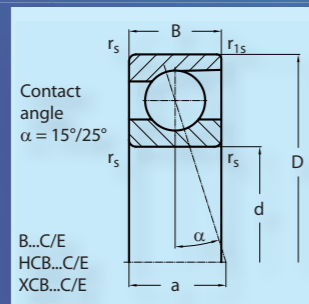

12. Measurement tables

Shaft	dimension (mm)						installation dimension (mm)				DLR-dimension (mm)				preload (N)			axial rigidity (N/μm)			load rating (kN)		speed limit (min ⁻¹)		Code	weight	
	d	D	B	a	r _s min	r _{1s} min	d _a h12	D _a H12	r _a max	r _b max	N _B	N _A	S _B	S _A	L	M	S	L	M	S	dyn C	stat Co	grease	oil	bearing	kg	
85	85	130	22	25	1,10	1,00	93,0	122,0	1,0	0,6					372	1205	2480	90,1	154,0	222,9	59,3	60,8	10 000		B7017C.2RSD.T.P4S.UL	0,903	
	85	130	22	36	1,10	1,00	93,0	122,0	1,0	0,6					544	1890	3950	211,0	336,9	457,1	55,9	56,5	9 000		B7017E.2RSD.T.P4S.UL	0,903	
	85	130	22	25	1,10	1,00	93,0	122,0	1,0	0,6	1,8	4,7	2,6	12,2	372	1205	2480	90,1	154,0	222,9	59,3	60,8	10 000	17 000	B7017C.T.P4S.UL	0,903	
	85	130	22	36	1,10	1,00	93,0	122,0	1,0	0,6	1,8	4,7	2,6	12,2	544	1890	3950	211,0	336,9	457,1	55,9	56,5	9 000	15 000	B7017E.T.P4S.UL	0,903	
	85	130	22	25	1,10	1,00	93,0	122,0	1,0	0,6	1,8	4,7	2,6	12,2	190	666	1400	78,0	129,9	185,0	59,3	42,6	13 000	20 000	HCB7017C.T.P4S.UL	0,778	
	85	130	22	36	1,10	1,00	93,0	122,0	1,0	0,6	1,8	4,7	2,6	12,2	262	1010	2180	185,0	300,0	401,0	55,9	39,6	11 000	18 000	HCB7017E.T.P4S.UL	0,778	
	85	130	22	25	1,10	1,00	93,0	122,0	1,0	0,6	1,8	4,7	2,6	12,2	190	666	1400	78,0	129,9	185,0	94,9	42,6	17 000	28 000	XCB7017C.T.P4S.UL	0,778	
	85	130	22	36	1,10	1,00	93,0	122,0	1,0	0,6	1,8	4,7	2,6	12,2	262	1010	2180	185,0	300,0	401,0	89,4	39,6	14 000	22 000	XCB7017E.T.P4S.UL	0,778	
	85	150	28	30	2,00	2,00	98,0	138,0	2,0	2,0					575	1830	3740	100,0	170,0	244,8	96,0	85,2	9 000	15 000	B7217C.T.P4S.UL	1,85	
	85	150	28	41	2,00	2,00	98,0	138,0	2,0	2,0					870	2890	5970	233,0	372,0	504,0	90,9	81,2	8 000	13 000	B7217E.T.P4S.UL	1,85	
	85	150	28	30	2,00	2,00	98,0	138,0	2,0	2,0					300	1000	2070	86,5	143,0	200,0	96,0	59,6	11 000	18 000	HCB7217C.T.P4S.UL	1,55	
	85	150	28	41	2,00	2,00	98,0	138,0	2,0	2,0					439	1570	3325	205,0	329,0	442,0	90,9	56,9	10 000	17 000	HCB7217E.T.P4S.UL	1,55	
	90	90	125	18	23	1,10	1,00	97,0	119,0	0,6	0,6					242	810	1690	82,5	142,0	206,0	37,4	39,5	10 000		B71918C.2RSD.T.P4S.UL	0,565
		90	125	18	34	1,10	1,00	97,0	119,0	0,6	0,6					339	1240	2660	190,0	310,0	424,0	35,1	36,8	9 000		B71918E.2RSD.T.P4S.UL	0,565
		90	125	18	23	1,10	1,00	97,0	119,0	0,6	0,6	1,8	4,0	2,4	10,4	242	810	1690	82,5	142,0	206,0	37,4	39,5	10 000	17 000	B71918C.T.P4S.UL	0,565
		90	125	18	34	1,10	1,00	97,0	119,0	0,6	0,6	1,8	4,0	2,4	10,4	339	1240	2660	190,0	310,0	424,0	35,1	36,8	9 000	15 000	B71918E.T.P4S.UL	0,565
90		125	18	23	1,10	1,00	97,0	119,0	0,6	0,6	1,8	4,0	2,4	10,4	121	444	950	70,7	120,0	170,2	37,4	27,6	13 000	20 000	HCB71918C.T.P4S.UL	0,493	
90		125	18	34	1,10	1,00	97,0	119,0	0,6	0,6	1,8	4,0	2,4	10,4	150	650	1460	162,0	275,0	375,0	35,1	25,8	11 000	18 000	HCB71918E.T.P4S.UL	0,493	
90		125	18	23	1,10	1,00	97,0	119,0	0,6	0,6	1,8	4,0	2,4	10,4	121	444	950	70,7	120,0	170,2	59,8	27,6	17 000	28 000	XCB71918C.T.P4S.UL	0,493	
90		125	18	34	1,10	1,00	97,0	119,0	0,6	0,6	1,8	4,0	2,4	10,4	150	650	1460	162,0	275,0	375,0	56,2	25,8	14 000	22 000	XCB71918E.T.P4S.UL	0,493	
90		140	24	27	1,50	1,10	100,0	131,0	1,5	0,6					440	1430	2930	96,2	164,0	235,0	75,1	76,0	9 500		B7018C.2RSD.T.P4S.UL	1,18	
90		140	24	39	1,50	1,10	100,0	131,0	1,5	0,6					650	2220	4630	222,8	357,0	482,0	70,8	70,6	8 500		B7018E.2RSD.T.P4S.UL	1,18	
90		140	24	27	1,50	1,10	100,0	131,0	1,5	0,6	1,8	4,4	2,6	13,3	440	1430	2930	96,2	164,0	235,0	75,1	76,0	9 500	16 000	B7018C.T.P4S.UL	1,18	
90		140	24	39	1,50	1,10	100,0	131,0	1,5	0,6	1,8	4,4	2,6	13,3	650	2220	4630	222,8	357,0	482,0	70,8	70,6	8 500	14 000	B7018E.T.P4S.UL	1,18	
90		140	24	27	1,50	1,10	100,0	131,0	1,5	0,6	1,8	4,4	2,6	13,3	223	777	1620	83,2	136,0	192,0	75,1	53,2	12 000	19 000	HCB7018C.T.P4S.UL	0,996	
90		140	24	39	1,50	1,10	100,0	131,0	1,5	0,6	1,8	4,4	2,6	13,3	320	1205	2590	198,0	320,0	428,0	70,8	49,4	10 000	17 000	HCB7018E.T.P4S.UL	0,996	
90		140	24	27	1,50	1,10	100,0	131,0	1,5	0,6	1,8	4,4	2,6	13,3	223	777	1620	83,2	136,0	192,0	120,2	53,2	15 000	24 000	XCB7018C.T.P4S.UL	0,996	
90		140	24	39	1,50	1,10	100,0	131,0	1,5	0,6	1,8	4,4	2,6	13,3	320	1205	2590	198,0	320,0	428,0	113,3	49,4	13 000	20 000	XCB7018E.T.P4S.UL	0,996	
90	160	30	32	2,00	2,00	104,0	147,0	2,0	2,0					740	2330	4750	110,0	186,0	268,0	118,1	110,3	8 500	14 000	B7218C.T.P4S.UL	2,25		
90	160	30	44	2,00	2,00	104,0	147,0	2,0	2,0					1140	3720	7650	256,0	405,0	550,0	111,9	105,3	7 500	12 000	B7218E.T.P4S.UL	2,25		
90	160	30	32	2,00	2,00	104,0	147,0	2,0	2,0					400	1310	2690	96,5	158,0	221,0	118,1	77,2	11 000	18 000	HCB7218C.T.P4S.UL	1,87		
90	160	30	44	2,00	2,00	104,0	147,0	2,0	2,0					580	2020	4250	231,0	363,0	485,0	111,9	73,7	9 000	15 000	HCB7218E.T.P4S.UL	1,87		

12. Measurement tables

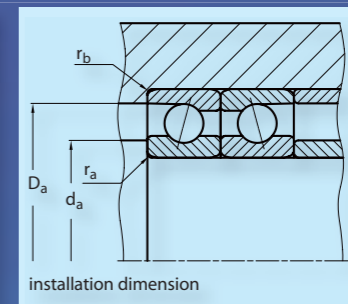
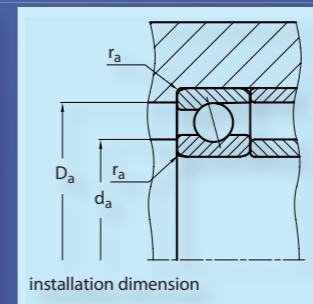
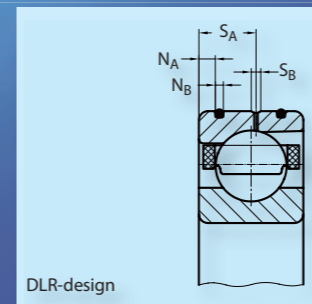
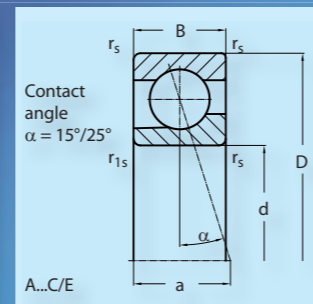
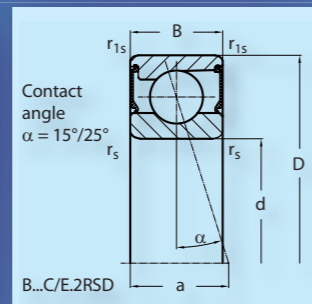
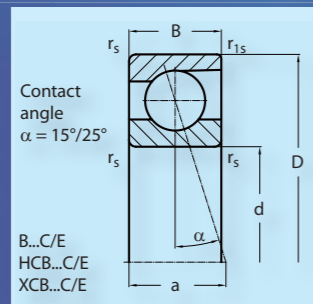

12. Measurement tables

Shaft	dimension (mm)						installation dimension (mm)				DLR-dimension (mm)				preload (N)			axial rigidity (N/μm)			load rating (kN)		speed limit (min ⁻¹)		Code	weight
	d	D	B	a	r _s min	r _{1s} min	d _a h12	D _a H12	r _a max	r _b max	N _B	N _A	S _B	S _A	L	M	S	L	M	S	dyn C	stat Co	grease	oil	bearing	kg
95	95	130	18	24	1,10	1,00	102,0	124,0	0,6	0,6					244	830	1720	84,6	146,0	211,9	43,3	46,6	9 500		B71919C.2RSD.T.P4S.UL	0,578
	95	130	18	35	1,10	1,00	102,0	124,0	0,6	0,6					345	1270	2715	195,0	320,5	436,8	40,7	43,4	8 500		B71919E.2RSD.T.P4S.UL	0,578
	95	130	18	24	1,10	1,00	102,0	124,0	0,6	0,6	1,8	4,0	2,4	10,4	244	830	1720	84,6	146,0	211,9	43,3	46,6	9 500	16 000	B71919C.T.P4S.UL	0,578
	95	130	18	35	1,10	1,00	102,0	124,0	0,6	0,6	1,8	4,0	2,4	10,4	345	1270	2715	195,0	320,5	436,8	40,7	43,4	8 500	14 000	B71919E.T.P4S.UL	0,578
	95	130	18	24	1,10	1,00	102,0	124,0	0,6	0,6	1,8	4,0	2,4	10,4	120	440	950	72,8	124,0	175,0	43,3	32,6	12 000	19 000	HCB71919C.T.P4S.UL	0,495
	95	130	18	35	1,10	1,00	102,0	124,0	0,6	0,6	1,8	4,0	2,4	10,4	150	665	1480	166,0	285,0	385,0	40,7	30,4	10 000	17 000	HCB71919E.T.P4S.UL	0,495
	95	130	18	24	1,10	1,00	102,0	124,0	0,6	0,6	1,8	4,0	2,4	10,4	120	440	950	72,8	124,0	175,0	69,3	32,6	16 000	26 000	XCB71919C.T.P4S.UL	0,495
	95	130	18	35	1,10	1,00	102,0	124,0	0,6	0,6	1,8	4,0	2,4	10,4	150	665	1480	166,0	285,0	385,0	65,1	30,4	14 000	22 000	XCB71919E.T.P4S.UL	0,495
	95	145	24	28	1,50	1,10	105,0	136,0	1,5	0,6					450	1450	2980	99,1	169,0	248,0	72,2	74,4	9 000		B7019C.2RSD.T.P4S.UL	1,19
	95	145	24	40	1,50	1,10	105,0	136,0	1,5	0,6					670	2315	4815	234,4	374,0	506,0	68,0	62,2	8 000		B7019E.2RSD.T.P4S.UL	1,19
	95	145	24	28	1,50	1,10	105,0	136,0	1,5	0,6	1,8	5,5	2,6	14,5	450	1450	2980	99,1	169,0	248,0	72,2	74,4	9 000	15 000	B7019C.T.P4S.UL	1,19
	95	145	24	40	1,50	1,10	105,0	136,0	1,5	0,6	1,8	5,5	2,6	14,5	670	2315	4815	234,4	374,0	506,0	68,0	62,2	8 000	13 000	B7019E.T.P4S.UL	1,19
	95	145	24	28	1,50	1,10	105,0	136,0	1,5	0,6	1,8	5,5	2,6	14,5	240	815	1690	86,7	144,5	202,5	72,2	52,1	11 000	18 000	HCB7019C.T.P4S.UL	1,02
	95	145	24	40	1,50	1,10	105,0	136,0	1,5	0,6	1,8	5,5	2,6	14,5	325	1230	2650	205,0	331,6	444,5	68,0	48,5	9 500	16 000	HCB7019E.T.P4S.UL	1,02
	95	145	24	28	1,50	1,10	105,0	136,0	1,5	0,6	1,8	5,5	2,6	14,5	240	815	1690	86,7	144,5	202,5	115,5	52,1	15 000	24 000	XCB7019C.T.P4S.UL	1,02
	95	145	24	40	1,50	1,10	105,0	136,0	1,5	0,6	1,8	5,5	2,6	14,5	325	1230	2650	205,0	331,6	444,5	108,8	48,5	13 000	20 000	XCB7019E.T.P4S.UL	1,02
95	170	32	34	2,10	2,10	110,5	154,0	2,0	2,0					770	2430	4930	114,9	196,0	282,0	117,9	107,3	8 000	13 000	B7219C.T.P4S.UL	2,72	
95	170	32	47	2,10	2,10	110,5	154,0	2,0	2,0					1195	3900	8040	274,2	432,0	582,0	111,7	102,3	7 000	11 000	B7219E.T.P4S.UL	2,72	
95	170	32	34	2,10	2,10	110,5	154,0	2,0	2,0					410	1350	2780	100,8	166,2	232,1	117,9	75,1	10 000	17 000	HCB7219C.T.P4S.UL	2,30	
95	170	32	47	2,10	2,10	110,5	154,0	2,0	2,0					600	2090	4400	243,0	382,6	510,0	111,7	71,6	8 500	14 000	HCB7219E.T.P4S.UL	2,30	
100	100	140	20	26	1,10	1,00	107,0	133,0	0,6	0,6					320	1060	2195	93,9	162,0	234,1	52,3	57,2	9 000		B71920C.2RSD.T.P4S.UL	0,882
	100	140	20	38	1,10	1,00	107,0	133,0	0,6	0,6					455	1630	3440	220,5	355,0	482,0	49,3	53,3	8 000		B71920E.2RSD.T.P4S.UL	0,882
	100	140	20	26	1,10	1,00	107,0	133,0	0,6	0,6	1,8	4,0	2,6	12,0	320	1060	2195	93,9	162,0	234,1	52,3	57,2	9 000	15 000	B71920C.T.P4S.UL	0,882
	100	140	20	38	1,10	1,00	107,0	133,0	0,6	0,6	1,8	4,0	2,6	12,0	455	1630	3440	220,5	355,0	482,0	49,3	53,3	8 000	13 000	B71920E.T.P4S.UL	0,882
	100	140	20	26	1,10	1,00	107,0	133,0	0,6	0,6	1,8	4,0	2,6	12,0	160	577	1220	81,2	136,3	192,0	52,3	40,1	11 000	18 000	HCB71920C.T.P4S.UL	0,758
	100	140	20	38	1,10	1,00	107,0	133,0	0,6	0,6	1,8	4,0	2,6	12,0	202	850	1880	187,5	314,0	424,3	49,3	37,3	9 500	16 000	HCB71920E.T.P4S.UL	0,758
	100	140	20	26	1,10	1,00	107,0	133,0	0,6	0,6	1,8	4,0	2,6	12,0	160	577	1220	81,2	136,3	192,0	83,7	40,1	15 000	24 000	XCB71920C.T.P4S.UL	0,758
	100	140	20	38	1,10	1,00	107,0	133,0	0,6	0,6	1,8	4,0	2,6	12,0	202	850	1880	187,5	314,0	424,3	78,8	37,3	12 000	19 000	XCB71920E.T.P4S.UL	0,758
	100	150	24	29	1,50	1,10	110,0	141,0	1,5	0,6					465	1520	3110	103,7	177,5	256,0	78,8	82,9	8 500		B7020C.2RSD.T.P4S.UL	1,28
	100	150	24	41	1,50	1,10	110,0	141,0	1,5	0,6					683	2345	4900	243,1	387,0	525,0	74,2	77,1	7 500		B7020E.2RSD.T.P4S.UL	1,28
100	150	24	29	1,50	1,10	110,0	141,0	1,5	0,6	1,8	5,5	2,6	14,5	465	1520	3110	103,7	177,5	256,0	78,8	82,9	8 500	14 000	B7020C.T.P4S.UL	1,28	
100	150	24	41	1,50	1,10	110,0	141,0	1,5	0,6	1,8	5,5	2,6	14,5	683	2345	4900	243,1	387,0	525,0	74,2	77,1	7 500	12 000	B7020E.T.P4S.UL	1,28	

12. Measurement tables

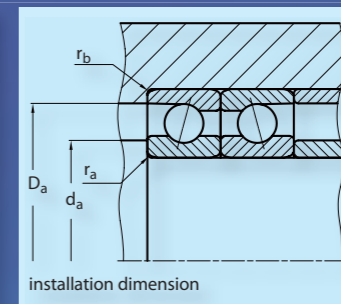
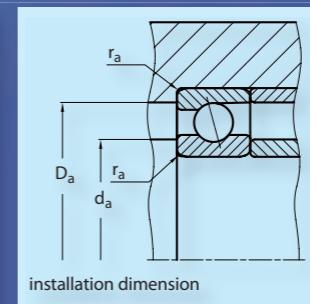
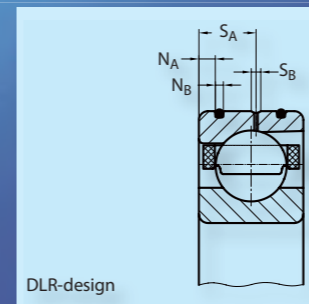
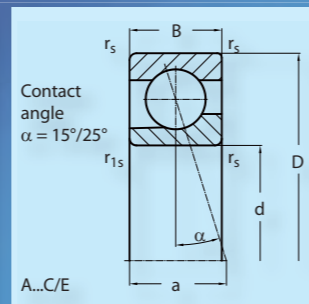
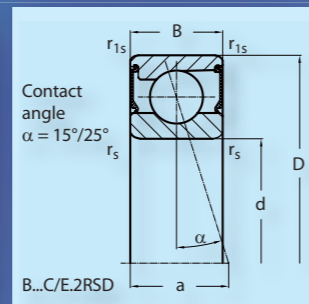
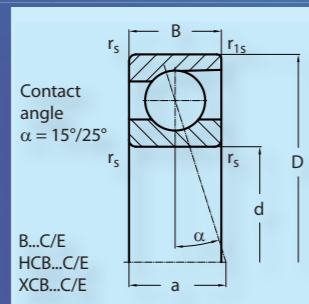

12. Measurement tables

Shaft	dimension (mm)						installation dimension (mm)				DLR-dimension (mm)				preload (N)			axial rigidity (N/μm)			load rating (kN)		speed limit (min ⁻¹)		Code	weight
	d	D	B	a	r _s min	r _{1s} min	d _a h12	D _a H12	r _a max	r _b max	N _B	N _A	S _B	S _A	L	M	S	L	M	S	dyn C	stat Co	grease	oil	bearing	kg
100	100	150	24	29	1,50	1,10	110,0	141,0	1,5	0,6	1,8	5,5	2,6	14,5	240	820	1705	89,2	149,5	208,5	78,8	58,1	11 000	18 000	HCB7020C.T.P4S.UL	1,08
	100	150	24	41	1,50	1,10	110,0	141,0	1,5	0,6	1,8	5,5	2,6	14,5	332	1270	2735	213,5	346,0	465,0	74,2	54,0	9 000	15 000	HCB7020E.T.P4S.UL	1,08
	100	150	24	29	1,50	1,10	110,0	141,0	1,5	0,6	1,8	5,5	2,6	14,5	240	820	1705	89,2	149,5	208,5	126,1	58,1	14 000	22 000	XCB7020C.T.P4S.UL	1,08
	100	150	24	41	1,50	1,10	110,0	141,0	1,5	0,6	1,8	5,5	2,6	14,5	332	1270	2735	213,5	346,0	465,0	118,7	54,0	12 000	19 000	XCB7020E.T.P4S.UL	1,08
	100	180	34	36	2,10	2,10	114,5	165,5	2,1	2,1	2,0	6,5	2,6	20,4	795	2520	5130	122,0	205,5	294,0	121,8	115,6	7 500	12 000	B7220C.T.P4S.UL	3,21
	100	180	34	50	2,10	2,10	114,5	165,5	2,1	2,1	2,0	6,5	2,6	20,4	1210	4000	8250	287,0	450,0	606,0	115,2	110,1	6 700	10 000	B7220E.T.P4S.UL	3,21
	100	180	34	36	2,10	2,10	114,5	165,5	2,1	2,1	2,0	6,5	2,6	20,4	430	1410	2900	105,9	174,6	245,0	121,8	80,9	9 500	16 000	HCB7220C.T.P4S.UL	2,76
	100	180	34	50	2,10	2,10	114,5	165,5	2,1	2,1	2,0	6,5	2,6	20,4	620	2180	5430	256,0	404,0	548,1	115,2	77,1	8 000	13 000	HCB7220E.T.P4S.UL	2,76
105	105	145	20	27	1,10	1,00	112,0	138,0	0,6	0,6					320	1060	2190	93,8	160,8	234,0	52,3	55,9	8 500		B71921C.2RSD.T.P4S.UL	0,810
	105	145	20	39	1,10	1,00	112,0	138,0	0,6	0,6					455	1630	3440	220,0	355,0	481,6	49,1	52,1	7 500		B71921E.2RSD.T.P4S.UL	0,810
	105	145	20	27	1,10	1,00	112,0	138,0	0,6	0,6	1,8	4,0	2,6	12,0	320	1060	2190	93,8	160,8	234,0	52,3	55,9	8 500	14 000	B71921C.T.P4S.UL	0,810
	105	145	20	39	1,10	1,00	112,0	138,0	0,6	0,6	1,8	4,0	2,6	12,0	455	1630	3440	220,0	355,0	481,6	49,1	52,1	7 500	12 000	B71921E.T.P4S.UL	0,810
	105	145	20	27	1,10	1,00	112,0	138,0	0,6	0,6	1,8	4,0	2,6	12,0	160	580	1220	81,5	137,8	190,5	52,3	39,1	11 000	18 000	HCB71921C.T.P4S.UL	0,686
	105	145	20	39	1,10	1,00	112,0	138,0	0,6	0,6	1,8	4,0	2,6	12,0	202	850	1880	186,9	315,0	424,3	49,1	36,4	9 000	15 000	HCB71921E.T.P4S.UL	0,686
	105	145	20	27	1,10	1,00	112,0	138,0	0,6	0,6	1,8	4,0	2,6	12,0	160	580	1220	81,5	137,8	190,5	83,6	39,1	14 000	22 000	XCB71921C.T.P4S.UL	0,686
	105	145	20	39	1,10	1,00	112,0	138,0	0,6	0,6	1,8	4,0	2,6	12,0	202	850	1880	186,9	315,0	424,3	78,6	36,4	12 000	19 000	XCB71921E.T.P4S.UL	0,686
	105	160	26	31	2,00	1,10	116,0	150,0	2,0	1,0					620	2000	4080	113,8	193,4	280,0	98,8	98,8	8 000		B7021C.2RSD.T.P4S.UL	1,52
	105	160	26	44	2,00	1,10	116,0	150,0	2,0	1,0					960	3200	6645	270,0	428,4	577,0	93,2	91,7	7 000		B7021E.2RSD.T.P4S.UL	1,52
	105	160	26	31	2,00	1,10	116,0	150,0	2,0	1,0	2,0	6,0	2,6	15,2	620	2000	4080	113,8	193,4	280,0	98,8	98,8	8 000	13 000	B7021C.T.P4S.UL	1,52
	105	160	26	44	2,00	1,10	116,0	150,0	2,0	1,0	2,0	6,0	2,6	15,2	960	3200	6645	270,0	428,4	577,0	93,2	91,7	7 000	11 000	B7021E.T.P4S.UL	1,52
	105	160	26	44	2,00	1,10	116,0	150,0	2,0	1,0	2,0	6,0	2,6	15,2	335	1130	2330	100,3	165,0	230,0	98,8	69,1	10 000	17 000	HCB7021C.T.P4S.UL	1,21
	105	160	26	44	2,00	1,10	116,0	150,0	2,0	1,0	2,0	6,0	2,6	15,2	470	1700	3620	236,0	380,0	505,0	93,2	64,2	8 500	14 000	HCB7021E.T.P4S.UL	1,21
	105	160	26	44	2,00	1,10	116,0	150,0	2,0	1,0	2,0	6,0	2,6	15,2	335	1130	2330	100,3	165,0	230,0	158,1	69,1	13 000	20 000	XCB7021C.T.P4S.UL	1,21
	105	160	26	44	2,00	1,10	116,0	150,0	2,0	1,0	2,0	6,0	2,6	15,2	470	1700	3620	236,0	380,0	505,0	149,2	64,2	11 000	18 000	XCB7021E.T.P4S.UL	1,21
105	190	36	38	2,10	2,10	120,5	174,5	2,1	2,1					1000	3130	6380	132,0	222,2	320,0	151,3	140,3	7 000	11 000	B7221C.T.P4S.UL	3,88	
105	190	36	52	2,10	2,10	120,5	174,5	2,1	2,1					1558	5050	10300	312,0	490,0	660,0	143,4	133,8	6 300	9 500	B7221E.T.P4S.UL	3,88	
105	190	36	38	2,10	2,10	120,5	174,5	2,1	2,1					530	1730	3560	114,8	188,0	263,0	151,3	98,2	9 000	15 000	HCB7221C.T.P4S.UL	3,25	
105	190	36	52	2,10	2,10	120,5	174,5	2,1	2,1					804	2760	5750	280,6	439,0	582,0	143,4	93,7	7 500	12 000	HCB7221E.T.P4S.UL	3,25	
110	110	150	20	27	1,10	1,00	117,0	143,0	0,6	0,6					315	1050	2190	96,5	164,5	235,0	52,7	59,0	8 000		B71922C.2RSD.T.P4S.UL	0,850
	110	150	20	40	1,10	1,00	117,0	143,0	0,6	0,6					460	1650	3495	226,3	365,0	496,0	49,6	55,0	7 500		B71922E.2RSD.T.P4S.UL	0,850
	110	150	20	27	1,10	1,00	117,0	143,0	0,6	0,6	1,8	4,0	2,6	12,0	315	1050	2190	96,5	164,5	235,0	52,7	59,0	8 000	13 000	B71922C.T.P4S.UL	0,850
	110	150	20	40	1,10	1,00	117,0	143,0	0,6	0,6	1,8	4,0	2,6	12,0	460	1650	3495	226,3	365,0	496,0	49,6	55,0	7 500	12 000	B71922E.T.P4S.UL	0,850

12. Measurement tables

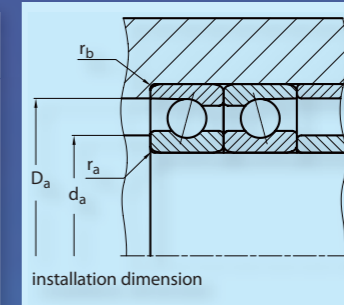
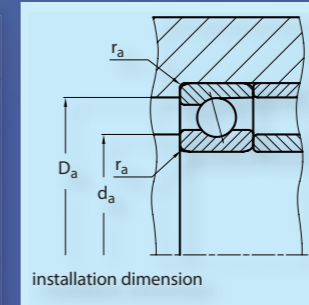
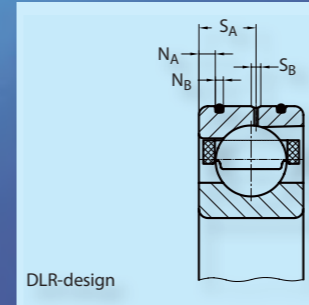
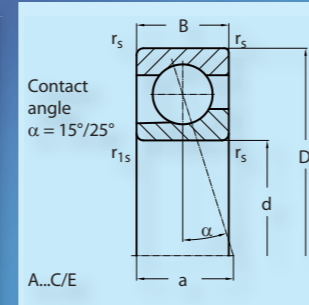
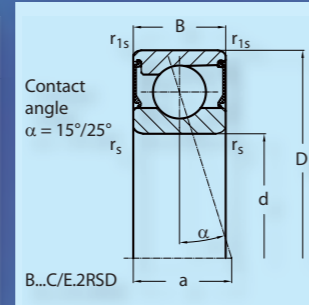
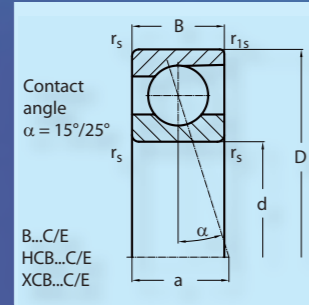

12. Measurement tables

Shaft	dimension (mm)						installation dimension (mm)				DLR-dimension (mm)				preload (N)			axial rigidity (N/μm)			load rating (kN)		speed limit (min ⁻¹)		Code	weight	
	d	D	B	a	r _s min	r _{1s} min	d _a h12	D _a H12	r _a max	r _b max	N _B	N _A	S _B	S _A	L	M	S	L	M	S	dyn C	stat Co	grease	oil	bearing	kg	
110	110	150	20	27	1,10	1,00	117,0	143,0	0,6	0,6	1,8	4,0	2,6	12,0	162	580	1235	84,4	142,0	197,5	52,7	41,3	10 000	17 000	HCB71922C.T.P4S.UL	0,721	
	110	150	20	40	1,10	1,00	117,0	143,0	0,6	0,6	1,8	4,0	2,6	12,0	203	860	1905	192,0	320,0	435,0	49,6	38,5	9 000	15 000	HCB71922E.T.P4S.UL	0,721	
	110	150	20	27	1,10	1,00	117,0	143,0	0,6	0,6	1,8	4,0	2,6	12,0	162	580	1235	84,4	142,0	197,5	84,4	41,3	13 000	20 000	XCB71922C.T.P4S.UL	0,721	
	110	150	20	40	1,10	1,00	117,0	143,0	0,6	0,6	1,8	4,0	2,6	12,0	203	860	1905	192,0	320,0	435,0	79,3	38,5	11 000	18 000	XCB71922E.T.P4S.UL	0,721	
	110	170	28	33	2,00	1,10	121,0	159,0	2,0	1,0					650	2070	4235	118,8	204,0	293,0	101,1	103,1	7 500		B7022C.2RSD.T.P4S.UL	1,94	
	110	170	28	47	2,00	1,10	121,0	159,0	2,0	1,0					975	3260	6760	284,0	445,0	600,0	95,3	95,8	6 700		B7022E.2RSD.T.P4S.UL	1,94	
	110	170	28	33	2,00	1,10	121,0	159,0	2,0	1,0	2,0	6,0	2,6	16,2	650	2070	4235	118,8	204,0	293,0	101,1	103,1	7 500	12 000	B7022C.T.P4S.UL	1,94	
	110	170	28	47	2,00	1,10	121,0	159,0	2,0	1,0	2,0	6,0	2,6	16,2	975	3260	6760	284,0	445,0	600,0	95,3	95,8	6 700	10 000	B7022E.T.P4S.UL	1,94	
	110	170	28	33	2,00	1,10	121,0	159,0	2,0	1,0	2,0	6,0	2,6	16,2	340	1145	2365	105,0	170,6	240,0	101,1	72,1	9 500	16 000	HCB7022C.T.P4S.UL	1,61	
	110	170	28	47	2,00	1,10	121,0	159,0	2,0	1,0	2,0	6,0	2,6	16,2	480	1740	3700	250,0	395,3	527,8	95,3	67,0	8 000	13 000	HCB7022E.T.P4S.UL	1,61	
	110	170	28	33	2,00	1,10	121,0	159,0	2,0	1,0	2,0	6,0	2,6	16,2	340	1145	2365	105,0	170,6	240,0	161,8	72,1	12 000	19 000	XCB7022C.T.P4S.UL	1,61	
	110	170	28	47	2,00	1,10	121,0	159,0	2,0	1,0	2,0	6,0	2,6	16,2	480	1740	3700	250,0	395,3	527,8	152,5	67,0	10 000	17 000	XCB7022E.T.P4S.UL	1,61	
	110	200	38	40	2,10	2,10	126,5	183,5	2,1	2,1	2,0	6,5	2,6	22,6	1000	3140	6380	131,0	222,2	322,0	150,3	142,1	6 700	10 000	B7222C.T.P4S.UL	4,59	
	110	200	38	55	2,10	2,10	126,5	183,5	2,1	2,1	2,0	6,5	2,6	22,6	1525	4940	10140	310,0	486,8	655,0	142,5	135,5	6 000	9 000	B7222E.T.P4S.UL	4,59	
	110	200	38	40	2,10	2,10	126,5	183,5	2,1	2,1	2,0	6,5	2,6	22,6	535	1740	3560	115,6	188,2	263,0	150,3	99,5	8 500	14 000	HCB7222C.T.P4S.UL	3,96	
	110	200	38	55	2,10	2,10	126,5	183,5	2,1	2,1	2,0	6,5	2,6	22,6	790	2705	5650	277,3	433,9	579,0	142,3	94,8	7 000	11 000	HCB7222E.T.P4S.UL	3,96	
	120	120	165	22	30	1,10	1,00	128,0	157,0	0,6	0,6					410	1345	2770	108,5	185,5	267,5	65,1	73,4	7 000		B71924C.2RSD.T.P4S.UL	1,16
		120	165	22	44	1,10	1,00	128,0	157,0	0,6	0,6					590	2090	4390	256,0	411,5	557,0	61,2	68,4	6 700		B71924E.2RSD.T.P4S.UL	1,16
120		165	22	30	1,10	1,00	128,0	157,0	0,6	0,6					410	1345	2770	108,5	185,5	267,5	65,1	73,4	7 000	11 000	B71924C.T.P4S.UL	1,16	
120		165	22	44	1,10	1,00	128,0	157,0	0,6	0,6					590	2090	4390	256,0	411,5	557,0	61,2	68,4	6 700	10 000	B71924E.T.P4S.UL	1,16	
120		165	22	30	1,10	1,00	128,0	157,0	0,6	0,6					210	740	1570	94,6	159,2	222,2	65,1	51,4	9 000	15 000	HCB71924C.T.P4S.UL	0,976	
120		165	22	44	1,10	1,00	128,0	157,0	0,6	0,6					276	1110	2420	221,6	365,9	492,0	61,2	47,9	8 000	13 000	HCB71924E.T.P4S.UL	0,976	
120		165	22	30	1,10	1,00	128,0	157,0	0,6	0,6					210	740	1570	94,6	159,2	222,2	104,2	51,4	12 000	19 000	XCB71924C.T.P4S.UL	0,976	
120		165	22	44	1,10	1,00	128,0	157,0	0,6	0,6					276	1110	2420	221,6	365,9	492,0	97,9	47,9	10 000	17 000	XCB71924E.T.P4S.UL	0,976	
120		180	28	34	2,00	1,10	131,0	169,0	2,0	1,0					660	2110	4310	124,0	209,5	302,0	102,8	107,1	6 700		B7024C.2RSD.T.P4S.UL	2,07	
120		180	28	49	2,00	1,10	131,0	169,0	2,0	1,0					990	3320	6880	289,6	460,0	622,0	96,8	99,6	6 300		B7024E.2RSD.T.P4S.UL	2,07	
120		180	28	34	2,00	1,10	131,0	169,0	2,0	1,0	2,0	6,0	2,6	16,2	660	2110	4310	124,0	209,5	302,0	102,8	107,1	6 700	10 000	B7024C.T.P4S.UL	2,07	
120		180	28	49	2,00	1,10	131,0	169,0	2,0	1,0	2,0	6,0	2,6	16,2	990	3320	6880	289,6	460,0	622,0	96,8	99,6	6 300	9 500	B7024E.T.P4S.UL	2,07	
120		180	28	34	2,00	1,10	131,0	169,0	2,0	1,0	2,0	6,0	2,6	16,2	350	1180	2440	106,5	178,0	250,0	102,8	75,0	8 500	14 000	HCB7024C.T.P4S.UL	1,72	
120		180	28	49	2,00	1,10	131,0	169,0	2,0	1,0	2,0	6,0	2,6	16,2	490	1780	3795	258,4	410,8	550,0	96,8	69,7	7 500	12 000	HCB7024E.T.P4S.UL	1,72	
120		180	28	34	2,00	1,10	131,0	169,0	2,0	1,0	2,0	6,0	2,6	16,2	350	1180	2440	106,5	178,0	250,0	164,5	75,0	11 000	18 000	XCB7024C.T.P4S.UL	1,72	
120		180	28	49	2,00	1,10	131,0	169,0	2,0	1,0	2,0	6,0	2,6	16,2	490	1780	3795	258,4	410,8	550,0	154,9	69,7	9 500	16 000	XCB7024E.T.P4S.UL	1,72	

12. Measurement tables

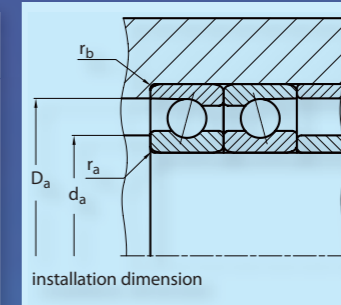
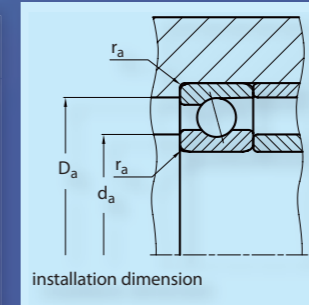
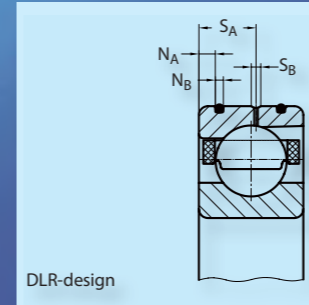
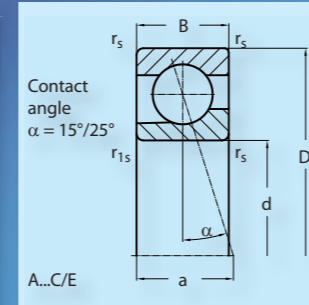
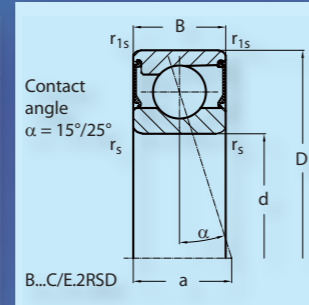
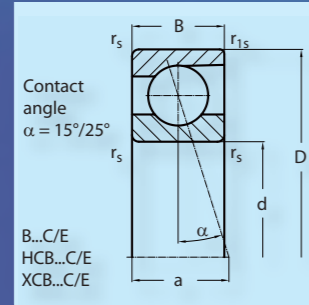

12. Measurement tables

Shaft	dimension (mm)						installation dimension (mm)				DLR-dimension (mm)				preload (N)			axial rigidity (N/μm)			load rating (kN)		speed limit (min ⁻¹)		Code	weight
	d	D	B	a	r _s min	r _{1s} min	d _a h12	D _a H12	r _a max	r _b max	N _B	N _A	S _B	S _A	L	M	S	L	M	S	dyn C	stat Co	grease	oil	bearing	kg
120	120	215	40	43	2,10	2,10	140,0	195,0	2,1	2,1					1270	3960	8040	139,6	234,0	335,7	189,4	183,7	6 000	9 000	B7224C.T.P4S.UL	5,29
	120	215	40	59	2,10	2,10	140,0	195,0	2,1	2,1					2000	6425	13100	334,0	520,0	700,0	180,1	175,6	5 300	8 000	B7224E.T.P4S.UL	5,29
	120	215	40	43	2,10	2,10	140,0	195,0	2,1	2,1					685	2190	4485	123,5	200,0	275,8	189,4	129,0	7 500	12 000	HCB7224C.T.P4S.UL	4,21
	120	215	40	59	2,10	2,10	140,0	195,0	2,1	2,1					1050	3500	7290	300,5	466,0	620,0	180,1	122,9	6 300	9 500	HCB7224E.T.P4S.UL	4,21
130	130	180	24	33	1,50	1,10	139,0	171,0	0,6	0,6					490	1600	3290	116,5	200,0	287,0	78,2	87,7	7 000		B71926C.2RSD.T.P4S.UL	1,52
	130	180	24	48	1,50	1,10	139,0	171,0	0,6	0,6					712	2480	5190	274,6	440,0	593,6	73,5	81,7	6 700		B71926E.2RSD.T.P4S.UL	1,52
	130	180	24	33	1,50	1,10	139,0	171,0	0,6	0,6					490	1600	3290	116,5	200,0	287,0	78,2	87,7	7 000	10 000	B71926C.T.P4S.UL	1,52
	130	180	24	48	1,50	1,10	139,0	171,0	0,6	0,6					712	2480	5190	274,6	440,0	593,6	73,5	81,7	6 700	9 000	B71926E.T.P4S.UL	1,52
	130	180	24	33	1,50	1,10	139,0	171,0	0,6	0,6					256	888	1858	101,9	170,5	235,8	78,2	61,4	8 500	14 000	HCB71926C.T.P4S.UL	1,28
	130	180	24	48	1,50	1,10	139,0	171,0	0,6	0,6					350	1355	2925	241,5	395,0	529,0	73,5	57,2	7 000	11 000	HCB71926E.T.P4S.UL	1,28
	130	180	24	33	1,50	1,10	139,0	171,0	0,6	0,6					256	888	1858	101,9	170,5	235,8	125,1	61,4	11 000	18 000	XCB71926C.T.P4S.UL	1,28
	130	180	24	48	1,50	1,10	139,0	171,0	0,6	0,6					350	1355	2925	241,5	395,0	529,0	117,6	57,2	9 500	16 000	XCB71926E.T.P4S.UL	1,28
	130	200	33	39	2,00	1,10	142,0	189,0	2,0	1,0					860	2720	5550	136,5	232,4	333,0	131,8	141,1	6 700		B7026C.2RSD.T.P4S.UL	3,15
	130	200	33	55	2,00	1,10	142,0	189,0	2,0	1,0					1320	4370	8960	329,0	517,2	692,2	124,3	132,8	6 000		B7026E.2RSD.T.P4S.UL	3,15
	130	200	33	39	2,00	1,10	142,0	189,0	2,0	1,0	2,0	6,0	2,6	19,5	860	2720	5550	136,5	232,4	333,0	131,8	141,1	6 700	9 000	B7026C.T.P4S.UL	3,15
	130	200	33	55	2,00	1,10	142,0	189,0	2,0	1,0	2,0	6,0	2,6	19,5	1320	4370	8960	329,0	517,2	692,2	124,3	132,8	6 000	8 500	B7026E.T.P4S.UL	3,15
	130	200	33	39	2,00	1,10	142,0	189,0	2,0	1,0	2,0	6,0	2,6	19,5	460	1520	3140	122,2	198,8	277,0	131,8	98,8	7 500	12 000	HCB7026C.T.P4S.UL	2,62
	130	200	33	55	2,00	1,10	142,0	189,0	2,0	1,0	2,0	6,0	2,6	19,5	675	2375	5020	290,5	460,5	615,0	124,3	93,0	6 700	10 000	HCB7026E.T.P4S.UL	2,62
	130	200	33	39	2,00	1,10	142,0	189,0	2,0	1,0	2,0	6,0	2,6	19,5	460	1520	3140	122,2	198,8	277,0	210,8	98,8	10 000	17 000	XCB7026C.T.P4S.UL	2,62
	130	200	33	55	2,00	1,10	142,0	189,0	2,0	1,0	2,0	6,0	2,6	19,5	675	2375	5020	290,5	460,5	615,0	198,9	93,0	8 500	14 000	XCB7026E.T.P4S.UL	2,62
130	230	40	44	3,00	3,00	148,0	211,5	2,5	2,5	2,0	9,0	2,6	24,5	1310	4100	8350	148,5	245,0	353,2	197,0	201,0	5 600	8 500	B7226C.T.P4S.UL	6,10	
130	230	40	62	3,00	3,00	148,0	211,5	2,5	2,5	2,0	9,0	2,6	24,5	2080	6675	13600	350,5	555,0	742,0	186,7	191,9	5 000	7 500	B7226E.T.P4S.UL	6,10	
130	230	40	44	3,00	3,00	148,0	211,5	2,5	2,5	2,0	9,0	2,6	24,5	720	2300	4700	129,5	212,0	292,5	197,0	140,7	7 000	11 000	HCB7226C.T.P4S.UL	5,00	
130	230	40	62	3,00	3,00	148,0	211,5	2,5	2,5	2,0	9,0	2,6	24,5	1080	3650	7520	316,0	496,0	654,0	186,7	134,3	6 000	9 000	HCB7226E.T.P4S.UL	5,00	
140	140	190	24	34	1,50	1,10	149,0	181,0	0,6	0,6					505	1665	3415	126,0	212,0	302,7	80,9	94,1	6 000		B71928C.2RSD.T.P4S.UL	1,63
	140	190	24	50	1,50	1,10	149,0	181,0	0,6	0,6					740	2580	5400	295,0	470,0	632,0	76,0	87,7	5 600		B71928E.2RSD.T.P4S.UL	1,63
	140	190	24	34	1,50	1,10	149,0	181,0	0,6	0,6					505	1665	3415	126,0	212,0	302,7	80,9	94,1	6 000	9 000	B71928C.T.P4S.UL	1,63
	140	190	24	50	1,50	1,10	149,0	181,0	0,6	0,6					740	2580	5400	295,0	470,0	632,0	76,0	87,7	5 600	8 500	B71928E.T.P4S.UL	1,63
	140	190	24	34	1,50	1,10	149,0	181,0	0,6	0,6					265	920	1930	109,4	183,0	252,0	80,9	65,8	7 500	12 000	HCB71928C.T.P4S.UL	1,37
	140	190	24	50	1,50	1,10	149,0	181,0	0,6	0,6					355	1390	3000	258,0	416,5	562,2	76,0	61,4	6 700	10 000	HCB71928E.T.P4S.UL	1,37
	140	190	24	34	1,50	1,10	149,0	181,0	0,6	0,6					265	920	1930	109,4	183,0	252,0	129,5	65,8	10 000	17 000	XCB71928C.T.P4S.UL	1,37
	140	190	24	50	1,50	1,10	149,0	181,0	0,6	0,6					355	1390	3000	258,0	416,5	562,2	121,7	61,4	8 500	14 000	XCB71928E.T.P4S.UL	1,37

12. Measurement tables

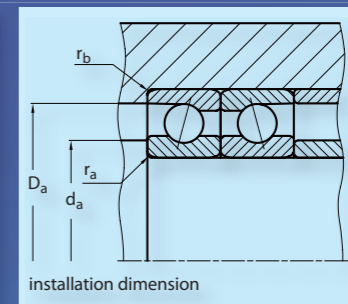
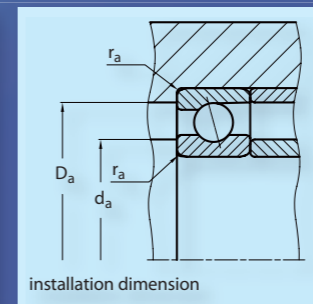
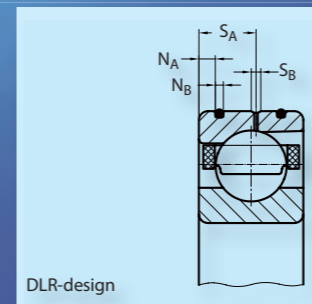
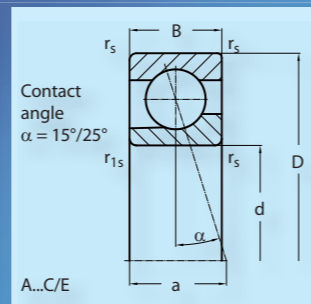
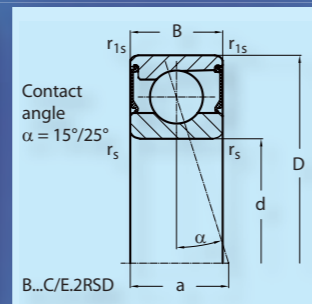
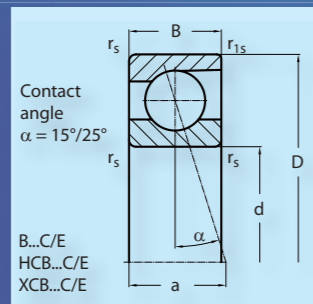

12. Measurement tables

Shaft	dimension (mm)						installation dimension (mm)				DLR-dimension (mm)				preload (N)			axial rigidity (N/μm)			load rating (kN)		speed limit (min ⁻¹)		Code	weight	
	d	D	B	a	r _s min	r _{1s} min	d _a h12	D _a H12	r _a max	r _b max	N _B	N _A	S _B	S _A	L	M	S	L	M	S	dyn C	stat Co	grease	oil	bearing	kg	
140	140	210	33	40	2,00	1,10	152,0	199,0	2,0	1,0					870	2775	5660	141,5	240,0	340,0	134,4	148,7	6 300		B7028C.2RSD.T.P4S.UL	3,34	
	140	210	33	57	2,00	1,10	152,0	199,0	2,0	1,0					1345	4445	9460	340,3	537,0	720,0	126,7	138,3	5 600		B7028E.2RSD.T.P4S.UL	3,34	
	140	210	33	40	2,00	1,10	152,0	199,0	2,0	1,0					870	2775	5660	141,5	240,0	340,0	134,4	148,7	6 300	8 500	B7028C.T.P4S.UL	3,34	
	140	210	33	57	2,00	1,10	152,0	199,0	2,0	1,0					1345	4445	9460	340,3	537,0	720,0	126,7	138,3	5 600	7 500	B7028E.T.P4S.UL	3,34	
	140	210	33	40	2,00	1,10	152,0	199,0	2,0	1,0					480	1580	3270	125,8	205,5	290,0	134,4	104,1	7 000	11 000	HCB7028C.T.P4S.UL	2,78	
	140	210	33	57	2,00	1,10	152,0	199,0	2,0	1,0					685	2435	5130	303,0	480,5	638,5	126,7	96,8	6 300	9 500	HCB7028E.T.P4S.UL	2,78	
	140	210	33	40	2,00	1,10	152,0	199,0	2,0	1,0					480	1580	3270	125,8	205,5	290,0	215,0	104,1	9 500	16 000	XCB7028C.T.P4S.UL	2,78	
	140	210	33	57	2,00	1,10	152,0	199,0	2,0	1,0					685	2435	5130	303,0	480,5	638,5	202,7	96,8	8 000	13 000	XCB7028E.T.P4S.UL	2,78	
	140	250	42	47	3,00	3,00	163,0	226,5	2,5	2,5					1360	4260	8640	154,8	260,0	370,0	220,5	247,9	5 000	7 500	B7228C.T.P4S.UL	7,87	
	140	250	42	66	3,00	3,00	163,0	226,5	2,5	2,5					2150	6930	14100	377,0	580,0	780,0	208,8	236,3	4 500	6 700	B7228E.T.P4S.UL	7,87	
	140	250	42	47	3,00	3,00	163,0	226,5	2,5	2,5					750	2400	4900	136,6	222,3	306,8	220,5	173,5	6 300	9 500	HCB7228C.T.P4S.UL	6,67	
	140	250	42	66	3,00	3,00	163,0	226,5	2,5	2,5					1130	3800	7910	340,0	522,6	690,0	208,8	165,4	5 300	8 000	HCB7228E.T.P4S.UL	6,67	
	150	150	210	28	38	2,00	1,10	160,0	199,0	1,0	1,0					710	2290	4680	140,5	238,0	342,0	110,3	124,5	5 600		B71930C.2RSD.T.P4S.UL	2,49
		150	210	28	56	2,00	1,10	160,0	199,0	1,0	1,0					1050	3540	7370	333,0	527,5	708,0	103,6	115,9	5 000		B71930E.2RSD.T.P4S.UL	2,49
150		210	28	38	2,00	1,10	160,0	199,0	1,0	1,0					710	2290	4680	140,5	238,0	342,0	110,3	124,5	5 600	8 500	B71930C.T.P4S.UL	2,49	
150		210	28	56	2,00	1,10	160,0	199,0	1,0	1,0					1050	3540	7370	333,0	527,5	708,0	103,6	115,9	5 000	7 500	B71930E.T.P4S.UL	2,49	
150		210	28	38	2,00	1,10	160,0	199,0	1,0	1,0					375	1260	2625	124,6	204,0	282,3	110,3	87,1	7 000	11 000	HCB71930C.T.P4S.UL	2,07	
150		210	28	56	2,00	1,10	160,0	199,0	1,0	1,0					520	1925	4115	295,0	471,4	630,0	103,6	81,1	6 000	9 000	HCB71930E.T.P4S.UL	2,07	
150		210	28	38	2,00	1,10	160,0	199,0	1,0	1,0					375	1260	2625	124,6	204,0	282,3	176,5	87,1	9 000	15 000	XCB71930C.T.P4S.UL	2,07	
150		210	28	56	2,00	1,10	160,0	199,0	1,0	1,0					520	1925	4115	295,0	471,4	630,0	165,8	81,1	8 000	13 000	XCB71930E.T.P4S.UL	2,07	
150		225	35	43	2,10	1,50	163,0	213,0	2,1	1,0					1100	3500	7150	156,0	265,3	378,4	167,5	183,5	5 300	8 000	B7030C.T.P4S.UL	3,99	
150		225	35	61	2,10	1,50	163,0	213,0	2,1	1,0					1700	5555	11420	373,2	584,2	785,0	158,0	173,3	4 800	7 000	B7030E.T.P4S.UL	3,99	
150		225	35	43	2,10	1,50	163,0	213,0	2,1	1,0					600	1960	4020	137,5	223,8	313,0	167,5	128,5	6 700	10 000	HCB7030C.T.P4S.UL	3,20	
150		225	35	61	2,10	1,50	163,0	213,0	2,1	1,0					900	3100	6500	335,5	527,5	700,0	158,0	121,3	5 600	8 500	HCB7030E.T.P4S.UL	3,20	
150		225	35	43	2,10	1,50	163,0	213,0	2,1	1,0					600	1960	4020	137,5	223,8	313,0	268,0	128,5	8 500	14 000	XCB7030C.T.P4S.UL	3,20	
150		225	35	61	2,10	1,50	163,0	213,0	2,1	1,0					900	3100	6500	335,5	527,5	700,0	252,8	121,3	7 500	12 000	XCB7030E.T.P4S.UL	3,20	
150		270	45	51	3,00	3,00	178,0	241,5	2,5	2,5					1400	4410	8950	165,5	274,0	388,5	226,9	268,2	4 500	6 700	B7230C.T.P4S.UL	10,1	
150		270	45	71	3,00	3,00	178,0	241,5	2,5	2,5					2190	7025	14400	393,3	605,5	815,0	214,5	255,3	4 000	6 000	B7230E.T.P4S.UL	10,1	
150	270	45	51	3,00	3,00	178,0	241,5	2,5	2,5					770	2470	5050	143,3	235,5	322,0	226,9	187,7	5 600	8 500	HCB7230C.T.P4S.UL	8,70		
150	270	45	71	3,00	3,00	178,0	241,5	2,5	2,5					1140	3860	8025	353,0	548,0	722,5	214,5	178,7	5 000	7 500	HCB7230E.T.P4S.UL	8,70		
160	160	220	28	40	2,00	1,10	170,0	209,0	1,0	1,0					730	2340	4790	145,5	245,3	353,0	111,5	128,6	5 000	7 500	B71932C.T.P4S.UL	2,62	
	160	220	28	58	2,00	1,10	170,0	209,0	1,0	1,0					1050	3600	7500	344,4	544,3	730,0	104,8	119,8	4 800	7 000	B71932E.T.P4S.UL	2,62	

12. Measurement tables

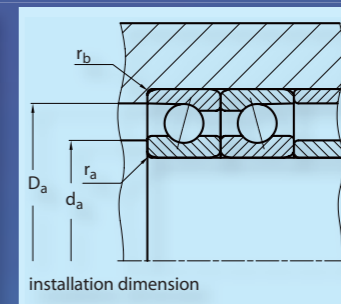
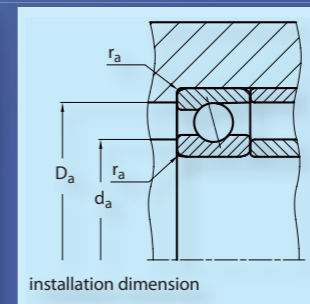
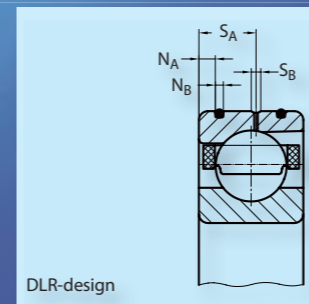
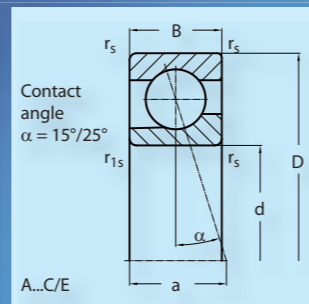
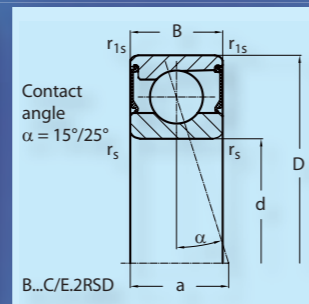
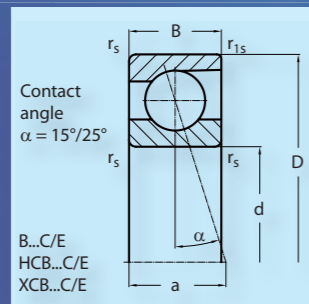

12. Measurement tables

Shaft	dimension (mm)						installation dimension (mm)				DLR-dimension (mm)				preload (N)			axial rigidity (N/μm)			load rating (kN)		speed limit (min ⁻¹)		Code	weight	
	d	D	B	a	r _s min	r _{1s} min	d _a h12	D _a H12	r _a max	r _b max	N _B	N _A	S _B	S _A	L	M	S	L	M	S	dyn C	stat Co	grease	oil	bearing	kg	
160	160	220	28	40	2,00	1,10	170,0	209,0	1,0	1,0					380	1285	2670	126,8	209,4	292,0	111,5	90,0	6 700	10 000	HCB71932C.T.P4S.UL	2,19	
	160	220	28	58	2,00	1,10	170,0	209,0	1,0	1,0					530	1965	4200	305,1	488,0	650,0	104,8	83,9	5 600	8 500	HCB71932E.T.P4S.UL	2,19	
	160	220	28	40	2,00	1,10	170,0	209,0	1,0	1,0					380	1285	2670	126,8	209,4	292,0	178,4	90,0	8 500	14 000	XCB71932C.T.P4S.UL	2,19	
	160	220	28	58	2,00	1,10	170,0	209,0	1,0	1,0					530	1965	4200	305,1	488,0	650,0	167,7	83,9	7 500	12 000	XCB71932E.T.P4S.UL	2,19	
	160	240	38	46	2,10	1,50	174,0	228,0	2,0	1,0					1150	3640	7400	163,3	275,0	395,0	170,6	193,9	4 800	7 000	B7032C.T.P4S.UL	5,01	
	160	240	38	66	2,10	1,50	174,0	228,0	2,0	1,0					1720	5640	11600	386,5	605,0	813,3	160,8	180,3	4 300	6 300	B7032E.T.P4S.UL	5,01	
	160	240	38	46	2,10	1,50	174,0	228,0	2,0	1,0					625	2030	4180	145,1	233,3	324,4	170,6	135,7	6 000	9 000	HCB7032C.T.P4S.UL	4,20	
	160	240	38	66	2,10	1,50	174,0	228,0	2,0	1,0					910	3160	6620	350,0	549,1	726,5	160,8	126,2	5 300	8 000	HCB7032E.T.P4S.UL	4,20	
	160	240	38	46	2,10	1,50	174,0	228,0	2,0	1,0					625	2030	4180	145,1	233,3	324,4	273,0	135,7	8 000	13 000	XCB7032C.T.P4S.UL	4,20	
	160	240	38	66	2,10	1,50	174,0	228,0	2,0	1,0					910	3160	6620	350,0	549,1	726,5	257,3	126,2	6 700	10 000	XCB7032E.T.P4S.UL	4,20	
	160	290	48	54	3,00	3,00	191,0	259,0	2,5	2,5					1500	4730	9600	182,0	300,0	425,0	241,3	304,5	4 300	6 300	B7232C.T.P4S.UL	12,9	
	160	290	48	76	3,00	3,00	191,0	259,0	2,5	2,5					2340	7530	15450	432,0	666,6	895,0	227,8	289,5	3 800	5 600	B7232E.T.P4S.UL	12,9	
	160	290	48	54	3,00	3,00	191,0	259,0	2,5	2,5					830	2660	5480	160,1	258,0	356,0	241,3	213,1	5 300	8 000	HCB7232C.T.P4S.UL	11,5	
	160	290	48	76	3,00	3,00	191,0	259,0	2,5	2,5					1230	4170	8670	390,0	606,0	798,0	227,8	202,6	4 500	6 700	HCB7232E.T.P4S.UL	11,5	
	170	170	230	28	41	2,00	1,10	180,0	219,0	1,0	1,0					750	2400	4950	152,0	260,6	370,0	115,5	137,7	4 800	7 000	B71934C.T.P4S.UL	2,78
		170	230	28	61	2,00	1,10	180,0	219,0	1,0	1,0					1100	3780	7870	365,0	580,0	779,0	108,5	128,3	4 300	6 300	B71934E.T.P4S.UL	2,78
170		230	28	41	2,00	1,10	180,0	219,0	1,0	1,0					390	1330	2770	135,1	222,0	309,0	115,5	96,4	6 000	9 000	HCB71934C.T.P4S.UL	2,31	
170		230	28	61	2,00	1,10	180,0	219,0	1,0	1,0					540	2030	4350	323,3	518,0	690,0	108,5	89,8	5 300	8 000	HCB71934E.T.P4S.UL	2,31	
170		260	42	50	2,10	2,10	185,0	246,0	2,0	1,0					1460	4560	9250	174,4	285,0	408,0	216,7	252,3	4 500	6 700	B7034C.T.P4S.UL	6,51	
170		260	42	71	2,10	2,10	185,0	246,0	2,0	1,0					2260	7280	14900	410,0	638,0	855,0	204,7	240,0	4 000	6 000	B7034E.T.P4S.UL	6,51	
170		310	52	58	4,00	4,00	205,0	275,0	3,0	3,0					1880	5840	11825	190,0	314,0	445,0	276,4	349,0	3 800	5 600	B7234C.T.P4S.UL	15,6	
170		310	52	82	4,00	4,00	205,0	275,0	3,0	3,0					2880	9185	18735	455,0	702,0	936,0	261,4	332,4	3 600	5 300	B7234E.T.P4S.UL	15,6	
180	180	250	33	46	2,00	1,10	192,0	238,0	1,0	1,0					962	3080	6300	168,8	282,0	401,0	147,4	179,2	4 500	6 700	B71936C.T.P4S.UL	4,13	
	180	250	33	67	2,00	1,10	192,0	238,0	1,0	1,0					1470	4915	10160	402,2	634,0	850,0	138,6	166,9	4 000	6 000	B71936E.T.P4S.UL	4,13	
	180	250	33	46	2,00	1,10	192,0	238,0	1,0	1,0					515	1700	3550	147,8	240,4	335,0	147,4	125,4	5 600	8 500	HCB71936C.T.P4S.UL	3,44	
	180	250	33	67	2,00	1,10	192,0	238,0	1,0	1,0					735	2640	5600	355,5	567,0	755,0	138,6	116,8	4 800	7 000	HCB71936E.T.P4S.UL	3,44	
	180	280	46	54	2,10	2,10	196,0	264,0	2,0	1,0					1510	4740	9600	179,9	300,0	425,0	221,8	270,3	4 000	6 000	B7036C.T.P4S.UL	8,77	
	180	280	46	77	2,10	2,10	196,0	264,0	2,0	1,0					2340	7530	15450	433,0	670,0	895,0	209,3	256,9	3 800	5 600	B7036E.T.P4S.UL	8,77	
	180	320	52	60	4,00	4,00	213,5	286,5	3,0	3,0					1900	5950	12000	200,0	329,0	465,0	285,1	373,1	3 800	5 600	B7236C.T.P4S.UL	16,3	
	180	320	52	84	4,00	4,00	213,5	286,5	3,0	3,0					2980	9500	19400	475,0	735,0	985,0	269,4	355,2	3 400	5 000	B7236E.T.P4S.UL	16,3	
190	190	260	33	47	2,00	1,10	202,0	247,0	1,0	1,0					895	3000	6200	166,6	282,0	408,0	149,3	185,1	4 300	6 300	B71938C.T.P4S.UL	4,31	
	190	260	33	69	2,00	1,10	202,0	247,0	1,0	1,0					1260	4575	9700	388,0	630,0	850,0	140,3	172,4	3 800	5 600	B71938E.T.P4S.UL	4,31	

12. Measurement tables

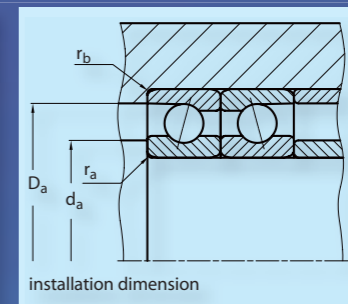
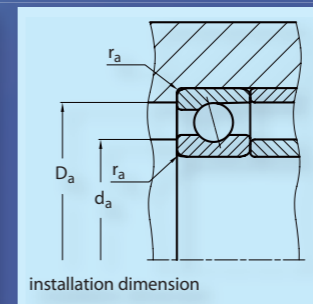
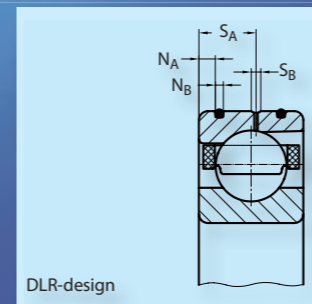
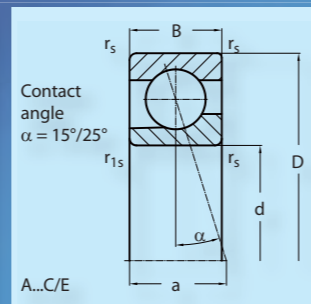
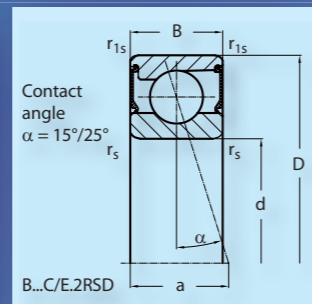
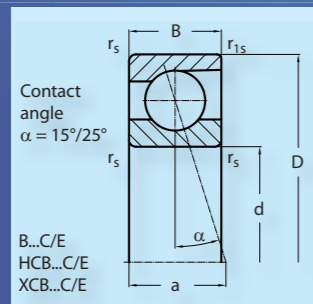

12. Measurement tables

Shaft	dimension (mm)						installation dimension (mm)				DLR-dimension (mm)				preload (N)			axial rigidity (N/μm)			load rating (kN)		speed limit (min ⁻¹)		Code	weight
	d	D	B	a	r _s min	r _{1s} min	d _a h12	D _a H12	r _a max	r _b max	N _B	N _A	S _B	S _A	L	M	S	L	M	S	dyn C	stat Co	grease	oil	bearing	kg
190	190	260	33	47	2,00	1,10	202,0	247,0	1,0	1,0					450	1620	3440	142,5	242,0	336,0	149,3	129,5	5 300	8 000	HCB71938C.T.P4S.UL	3,59
	190	260	33	69	2,00	1,10	202,0	247,0	1,0	1,0					565	2400	5310	333,3	560,0	757,0	140,3	120,7	4 500	6 700	HCB71938E.T.P4S.UL	3,59
	190	290	46	55	2,10	2,10	206,0	274,0	2,0	1,0					1450	4670	9580	181,0	303,0	440,0	227,5	287,0	3 800	5 600	B7038C.T.P4S.UL	9,18
	190	290	46	79	2,10	2,10	206,0	274,0	2,0	1,0					2150	7285	15230	430,0	680,0	913,0	214,6	270,8	3 600	5 300	B7038E.T.P4S.UL	9,18
	190	340	55	63	4,00	4,00	223,5	306,5	3,0	3,0					1860	5960	12160	202,0	335,0	478,0	292,4	399,1	3 400	5 000	B7238C.T.P4S.UL	20,0
	190	340	55	89	4,00	4,00	223,5	306,5	3,0	3,0					2815	9425	19525	485,0	760,0	1015,0	275,0	371,1	3 200	4 800	B7238E.T.P4S.UL	20,0
200	200	280	38	51	2,10	1,50	214,0	266,0	1,0	1,0					1135	3735	7700	180,0	305,0	435,0	183,4	225,3	3 800	5 600	B71940C.T.P4S.UL	6,03
	200	280	38	75	2,10	1,50	214,0	266,0	1,0	1,0					1645	5800	12200	425,0	680,0	915,0	172,5	209,8	3 600	5 300	B71940E.T.P4S.UL	6,03
	200	280	38	51	2,10	1,50	214,0	266,0	1,0	1,0					580	2030	4270	155,5	260,0	360,0	183,4	157,7	5 000	7 500	HCB71940C.T.P4S.UL	5,04
	200	280	38	75	2,10	1,50	214,0	266,0	1,0	1,0					760	3060	6660	365,0	602,0	810,0	172,5	146,9	4 300	6 300	HCB71940E.T.P4S.UL	5,04
	200	310	51	60	2,10	2,10	217,0	293,0	2,0	1,0					1800	5770	11780	194,0	322,0	458,0	284,1	374,9	3 600	5 300	B7040C.T.P4S.UL	11,6
	200	310	51	85	2,10	2,10	217,0	293,0	2,0	1,0					2730	9120	18890	463,0	725,0	970,0	268,4	354,3	3 200	4 800	B7040E.T.P4S.UL	11,6
	200	360	58	67	4,00	4,00	238,5	321,5	3,0	3,0					1915	6140	12500	210,5	350,0	498,0	299,1	417,6	3 200	4 800	B7240C.T.P4S.UL	24,1
	200	360	58	94	4,00	4,00	238,5	321,5	3,0	3,0					2900	9725	20160	506,0	795,0	1060,0	282,1	388,1	3 000	4 500	B7240E.T.P4S.UL	24,1
220	220	300	38	54	2,10	1,50	234,0	286,0	1,0	1,0					1190	3940	8140	197,0	332,0	475,0	193,6	250,0	3 600	5 300	B71944C.T.P4S.UL	6,57
	220	300	38	80	2,10	1,50	234,0	286,0	1,0	1,0					1715	6085	12865	463,0	742,0	998,0	182,0	232,9	3 200	4 800	B71944E.T.P4S.UL	6,57
	220	300	38	54	2,10	1,50	234,0	286,0	1,0	1,0					620	2180	4600	172,2	285,0	398,0	193,6	175,0	4 500	6 700	HCB71944C.T.P4S.UL	5,46
	220	300	38	80	2,10	1,50	234,0	286,0	1,0	1,0					800	3260	7120	400,0	660,0	890,0	182,0	163,0	3 800	5 600	HCB71944E.T.P4S.UL	5,46
	220	340	56	66	3,00	3,00	239,0	321,0	2,5	1,0					1915	6140	12540	213,0	352,0	500,0	299,1	417,6	3 200	4 800	B7044C.T.P4S.UL	15,7
	220	340	56	93	3,00	3,00	239,0	321,0	2,5	1,0					2905	9730	20165	507,0	795,0	1063,0	282,1	388,1	3 000	4 500	B7044E.T.P4S.UL	15,7
	220	400	65	74	4,00	4,00	264,0	356,0	3,0	3,0					2405	7620	15565	225,0	370,0	525,0	364,3	527,0	2 800	4 300	B7244C.T.P4S.UL	33,0
	220	400	65	104	4,00	4,00	264,0	356,0	3,0	3,0					3670	12080	24980	543,0	844,0	1130,0	344,3	501,5	2 600	4 000	B7244E.T.P4S.UL	33,0
240	240	320	38	57	2,10	1,50	254,0	307,0	1,0	1,0					1230	4080	8430	208,0	350,0	500,0	202,8	267,9	3 200	4 800	B71948C.T.P4S.UL	7,08
	240	320	38	84	2,10	1,50	254,0	307,0	1,0	1,0					1770	6300	13350	490,0	785,0	1060,0	190,6	249,6	3 000	4 500	B71948E.T.P4S.UL	7,08
	240	320	38	57	2,10	1,50	254,0	307,0	1,0	1,0					630	2240	4730	179,8	300,0	420,0	202,8	187,5	4 000	6 000	HCB71948C.T.P4S.UL	5,89
	240	320	38	84	2,10	1,50	254,0	307,0	1,0	1,0					795	3280	7200	420,0	695,0	930,0	190,6	174,7	3 600	5 300	HCB71948E.T.P4S.UL	5,89
	240	360	56	68	3,00	3,00	260,0	341,0	2,5	1,0					1970	6330	12925	220,0	365,0	518,0	304,3	434,0	3 000	4 500	B7048C.T.P4S.UL	16,7
	240	360	56	98	3,00	3,00	260,0	341,0	2,5	1,0					2930	9865	20450	520,0	820,0	1100,0	286,7	403,6	2 800	4 300	B7048E.T.P4S.UL	16,7
260	260	360	46	65	2,10	1,50	278,0	342,0	1,0	1,0					1630	5290	10875	222,2	372,3	529,0	254,9	365,9	3 000	4 500	B71952C.T.P4S.UL	12,1
	260	360	46	95	2,10	1,50	278,0	342,0	1,0	1,0					2390	8250	17270	530,0	840,0	1130,0	239,7	340,8	2 600	4 000	B71952E.T.P4S.UL	12,1
280	280	380	46	67	2,10	1,50	298,0	362,0	1,0	1,0					1700	5560	11440	239,0	398,0	560,0	263,4	391,2	2 600	4 000	B71956C.T.P4S.UL	12,9
	280	380	46	100	2,10	1,50	298,0	362,0	1,0	1,0					2460	8530	17850	560,0	890,0	1190,0	247,5	364,5	2 400	3 800	B71956E.T.P4S.UL	12,9

12. Measurement tables

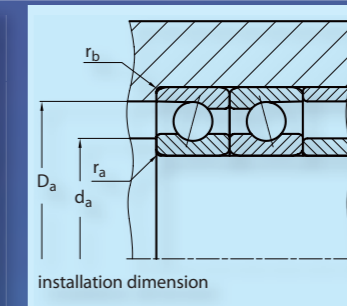
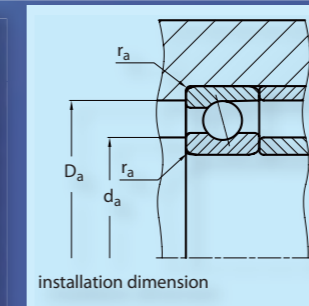
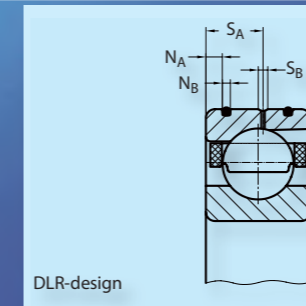
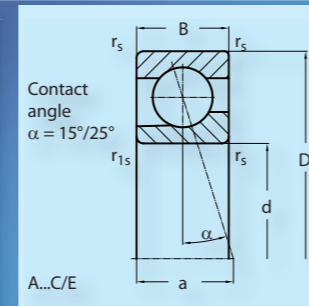
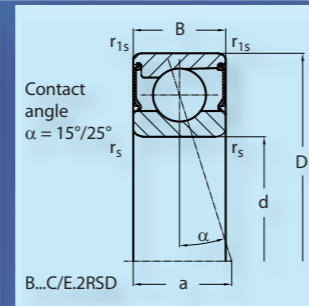
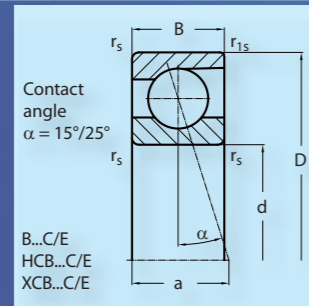

12. Measurement tables

Shaft	dimension (mm)						installation dimension (mm)				DLR-dimension (mm)				preload (N)			axial rigidity (N/μm)			load rating (kN)		speed limit (min ⁻¹)		Code	weight
	d	D	B	a	r _s min	r _{1s} min	d _a h12	D _a H12	r _a max	r _b max	N _B	N _A	S _B	S _A	L	M	S	L	M	S	dyn C	stat Co	grease	oil	bearing	kg
300	300	420	56	76	3,00	3,00	322,0	398,0	1,5	1,0					2100	6770	13860	250,0	414,0	585,0	326,7	504,3	2 400	3 800	B71960C.T.P4S.UL	20,4
	300	420	56	112	3,00	3,00	322,0	398,0	1,5	1,0					3120	10570	21990	600,0	940,0	1250,0	307,1	469,6	2 200	3 600	B71960E.T.P4S.UL	20,4
320	320	440	56	79	3,00	3,00	342,0	418,0	1,5	1,0					2180	7020	14400	267,0	440,0	620,0	339,3	543,4	2 200	3 600	B71964C.T.P4S.UL	21,6
	320	440	56	117	3,00	3,00	342,0	418,0	1,5	1,0					3240	11000	22900	640,0	1000,0	1335,0	318,9	506,2	2 000	3 400	B71964E.T.P4S.UL	21,6
340	340	460	56	82	3,00	3,00	362,0	438,0	1,5	1,0					2060	6880	14300	266,6	444,4	625,0	342,8	560,3	2 200	3 600	B71968C.T.P4S.UL	22,7
	340	460	56	121	3,00	3,00	362,0	438,0	1,5	1,0					2920	10600	22500	633,0	1010,0	1350,0	322,0	522,1	1 900	3 200	B71968E.T.P4S.UL	22,7
360	360	480	56	84	3,00	3,00	382,0	458,0	1,5	1,0					2100	7040	14640	280,0	465,0	655,0	354,0	597,1	2 000	3 400	B71972C.T.P4S.UL	23,9
	360	480	56	126	3,00	3,00	382,0	458,0	1,5	1,0					3030	11030	23400	670,0	1070,0	1440,0	332,5	556,6	1 800	3 000	B71972E.T.P4S.UL	23,9

12. Measurement tables

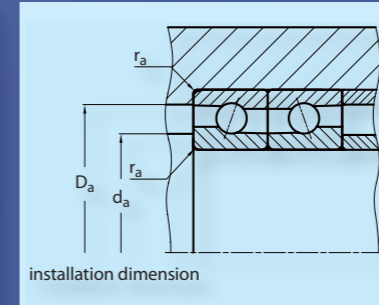
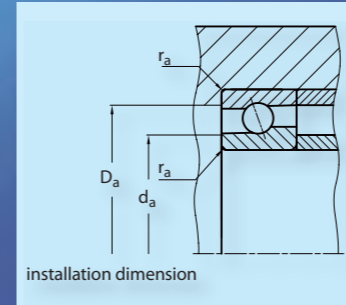
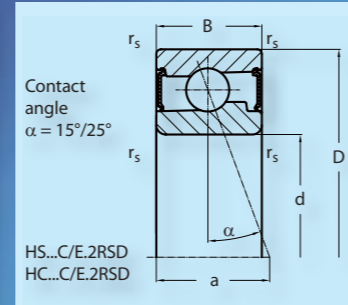
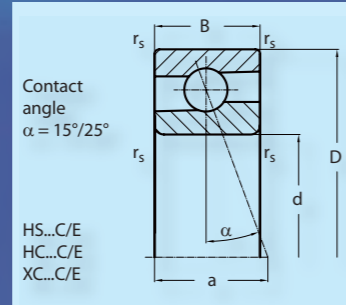

12. Measurement tables

12.2. High-speed spindle bearing

Shaft	dimension (mm)					installation dimension (mm)			preload (N)			axial rigidity (N/μm)			load rating (kN)		speed limit (min ⁻¹)		Code	weight	
	d	D	B	a	r _s min	d _a h12	D _a H12	r _a max	L	M	S	L	M	S	dyn C	stat Co	grease	oil	bearing	kg	
17	17	35	10	9	0,3	21,0	32,0	0,3	13	39	78	14,5	22,5	31,5	2,9	1,6	53 000		HS7003C.2RSD.T.P4S.UL	0,040	
	17	35	10	11	0,3	21,0	32,0	0,3	21	63	126	35,8	52,9	69,3	2,7	1,5	45 000		HS7003E.2RSD.T.P4S.UL	0,040	
	17	35	10	9	0,3	21,0	32,0	0,3	9	27	54	14,2	21,3	29,2	2,9	1,1	63 000		HC7003C.2RSD.T.P4S.UL	0,039	
	17	35	10	11	0,3	21,0	32,0	0,3	14	42	84	35,5	52,1	68,2	2,7	1,0	53 000		HC7003E.2RSD.T.P4S.UL	0,039	
	17	35	10	9	0,3	21,0	32,0	0,3	13	39	78	14,5	22,5	31,5	2,9	1,6	53 000	80 000	HS7003C.T.P4S.UL	0,040	
	17	35	10	11	0,3	21,0	32,0	0,3	21	63	126	35,8	52,9	69,3	2,7	1,5	45 000	67 000	HS7003E.T.P4S.UL	0,040	
	17	35	10	9	0,3	21,0	32,0	0,3	9	27	54	14,2	21,3	29,2	2,9	1,1	63 000	95 000	HC7003C.T.P4S.UL	0,039	
	17	35	10	11	0,3	21,0	32,0	0,3	14	42	84	35,5	52,1	68,2	2,7	1,0	53 000	80 000	HC7003E.T.P4S.UL	0,039	
	17	35	10	9	0,3	21,0	32,0	0,3	9	27	54	14,2	21,3	29,2	4,6	1,1	80 000	130 000	XC7003C.T.P4S.UL	0,039	
	17	35	10	11	0,3	21,0	32,0	0,3	14	42	84	35,5	52,1	68,2	4,3	1,0	70 000	100 000	XC7003E.T.P4S.UL	0,039	
	20	20	37	9	8	0,3	24,0	33,5	0,3	13	39	79	15,0	23,5	32,7	3,0	1,7	50 000		HS71904C.2RSD.T.P4S.UL	0,040
		20	37	9	11	0,3	24,0	33,5	0,3	21	63	126	37,0	55,0	72,8	2,9	1,6	43 000		HS71904E.2RSD.T.P4S.UL	0,040
		20	37	9	8	0,3	24,0	33,5	0,3	9	27	54	14,5	22,5	31,0	3,0	1,2	56 000		HC71904C.2RSD.T.P4S.UL	0,039
		20	37	9	11	0,3	24,0	33,5	0,3	15	45	90	37,5	54,5	71,5	2,9	1,1	48 000		HC71904E.2RSD.T.P4S.UL	0,039
20		37	9	8	0,3	24,0	33,5	0,3	13	39	79	15,0	23,5	32,7	3,0	1,7	50 000	75 000	HS71904C.T.P4S.UL	0,040	
20		37	9	11	0,3	24,0	33,5	0,3	21	63	126	37,0	55,0	72,8	2,9	1,6	43 000	63 000	HS71904E.T.P4S.UL	0,040	
20		37	9	8	0,3	24,0	33,5	0,3	9	27	54	14,5	22,5	31,0	3,0	1,2	56 000	85 000	HC71904C.T.P4S.UL	0,039	
20		37	9	11	0,3	24,0	33,5	0,3	15	45	90	37,5	54,5	71,5	2,9	1,1	48 000	70 000	HC71904E.T.P4S.UL	0,039	
20		37	9	8	0,3	24,0	33,5	0,3	9	27	54	14,5	22,5	31,0	4,9	1,2	75 000	120 000	XC71904C.T.P4S.UL	0,039	
20		37	9	11	0,3	24,0	33,5	0,3	15	45	90	37,5	54,5	71,5	4,6	1,1	63 000	95 000	XC71904E.T.P4S.UL	0,039	
20		42	12	10	0,6	25,0	37,0	0,6	20	63	126	20,0	31,5	43,5	4,7	2,7	45 000		HS7004C.2RSD.T.P4S.UL	0,080	
20		42	12	13	0,6	25,0	37,0	0,6	34	102	204	49,3	73,5	96,0	4,4	2,5	38 000		HS7004E.2RSD.T.P4S.UL	0,080	
20		42	12	10	0,6	25,0	37,0	0,6	15	45	90	19,5	30,0	41,0	4,7	1,9	53 000		HC7004C.2RSD.T.P4S.UL	0,077	
20		42	12	13	0,6	25,0	37,0	0,6	23	69	138	49,0	72,5	94,0	4,4	1,8	45 000		HC7004E.2RSD.T.P4S.UL	0,077	
20		42	12	10	0,6	25,0	37,0	0,6	20	63	126	20,0	31,5	43,5	4,7	2,7	45 000	67 000	HS7004C.T.P4S.UL	0,080	
20		42	12	13	0,6	25,0	37,0	0,6	34	102	204	49,3	73,5	96,0	4,4	2,5	38 000	56 000	HS7004E.T.P4S.UL	0,080	
20		42	12	10	0,6	25,0	37,0	0,6	15	45	90	19,5	30,0	41,0	4,7	1,9	53 000	80 000	HC7004C.T.P4S.UL	0,077	
20		42	12	13	0,6	25,0	37,0	0,6	23	69	138	49,0	72,5	94,0	4,4	1,8	45 000	67 000	HC7004E.T.P4S.UL	0,077	
20		42	12	10	0,6	25,0	37,0	0,6	15	45	90	19,5	30,0	41,0	7,5	1,9	67 000	100 000	XC7004C.T.P4S.UL	0,077	
20		42	12	13	0,6	25,0	37,0	0,6	23	69	138	49,0	72,5	94,0	7,1	1,8	56 000	85 000	XC7004E.T.P4S.UL	0,077	

12. Measurement tables

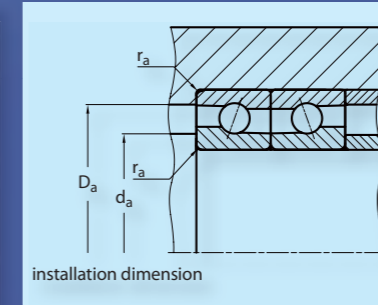
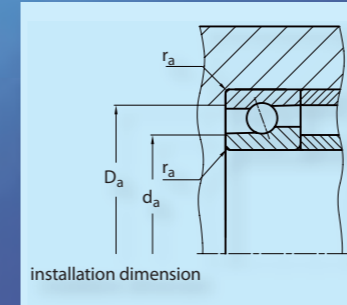
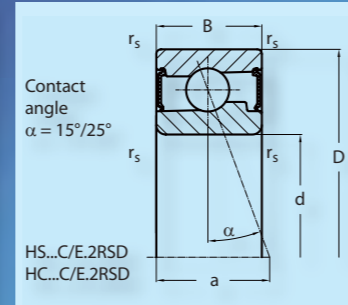
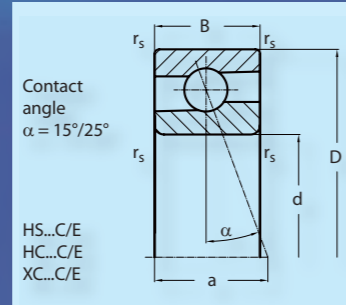

12. Measurement tables

Shaft	dimension (mm)					installation dimension (mm)			preload (N)			axial rigidity (N/μm)			load rating (kN)		speed limit (min ⁻¹)		Code	weight
	d	D	B	a	r _s min	d _a H12	D _a H12	r _a max	L	M	S	L	M	S	dyn C	stat Co	grease	oil	bearing	kg
25	25	42	9	9	0,3	29,0	38,5	0,3	14	42	84	17,0	26,5	36,5	3,3	2,1	43 000		HS71905C.2RSD.T.P4S.UL	0,050
	25	42	9	12	0,3	29,0	38,5	0,3	23	69	138	42,0	63,0	82,5	3,1	2,0	36 000		HS71905E.2RSD.T.P4S.UL	0,050
	25	42	9	9	0,3	29,0	38,5	0,3	10	30	60	16,5	25,5	34,5	3,3	1,5	48 000		HC71905C.2RSD.T.P4S.UL	0,048
	25	42	9	12	0,3	29,0	38,5	0,3	16	48	96	42,5	62,0	80,0	3,1	1,4	40 000		HC71905E.2RSD.T.P4S.UL	0,048
	25	42	9	9	0,3	29,0	38,5	0,3	14	42	84	17,0	26,5	36,5	3,3	2,1	43 000	63 000	HS71905C.T.P4S.UL	0,050
	25	42	9	12	0,3	29,0	38,5	0,3	23	69	138	42,0	63,0	82,5	3,1	2,0	36 000	53 000	HS71905E.T.P4S.UL	0,050
	25	42	9	9	0,3	29,0	38,5	0,3	10	30	60	16,5	25,5	34,5	3,3	1,5	48 000	70 000	HC71905C.T.P4S.UL	0,048
	25	42	9	12	0,3	29,0	38,5	0,3	16	48	96	42,5	62,0	80,0	3,1	1,4	40 000	60 000	HC71905E.T.P4S.UL	0,048
	25	42	9	9	0,3	29,0	38,5	0,3	10	30	60	16,5	25,5	34,5	5,2	1,5	63 000	95 000	XC71905C.T.P4S.UL	0,048
	25	42	9	12	0,3	29,0	38,5	0,3	16	48	96	42,5	62,0	80,0	5,0	1,4	53 000	80 000	XC71905E.T.P4S.UL	0,048
	25	47	12	11	0,6	30,0	42,0	0,6	21	63	126	20,5	33,0	45,5	4,7	2,9	38 000		HS7005C.2RSD.T.P4S.UL	0,090
	25	47	12	14	0,6	30,0	42,0	0,6	35	105	210	51,5	76,5	100,5	4,5	2,7	34 000		HS7005E.2RSD.T.P4S.UL	0,090
	25	47	12	11	0,6	30,0	42,0	0,6	15	45	90	20,1	31,5	42,0	4,7	2,0	45 000		HC7005C.2RSD.T.P4S.UL	0,087
	25	47	12	14	0,6	30,0	42,0	0,6	24	72	144	51,0	75,0	98,0	4,5	1,9	38 000		HC7005E.2RSD.T.P4S.UL	0,087
	25	47	12	11	0,6	30,0	42,0	0,6	21	63	126	20,5	33,0	45,5	4,7	2,9	38 000	56 000	HS7005C.T.P4S.UL	0,090
	25	47	12	14	0,6	30,0	42,0	0,6	35	105	210	51,5	76,5	100,5	4,5	2,7	34 000	50 000	HS7005E.T.P4S.UL	0,090
25	47	12	11	0,6	30,0	42,0	0,6	15	45	90	20,1	31,5	42,0	4,7	2,0	45 000	67 000	HC7005C.T.P4S.UL	0,087	
25	47	12	14	0,6	30,0	42,0	0,6	24	72	144	51,0	75,0	98,0	4,5	1,9	38 000	56 000	HC7005E.T.P4S.UL	0,087	
25	47	12	11	0,6	30,0	42,0	0,6	15	45	90	20,1	31,5	42,0	7,6	2,0	60 000	90 000	XC7005C.T.P4S.UL	0,087	
25	47	12	14	0,6	30,0	42,0	0,6	24	72	144	51,0	75,0	98,0	7,2	1,9	50 000	75 000	XC7005E.T.P4S.UL	0,087	
30	30	47	9	10	0,3	34,0	43,5	0,3	21	63	126	21,3	33,5	47,0	4,9	3,2	36 000		HS71906C.2RSD.T.P4S.UL	0,050
	30	47	9	13	0,3	34,0	43,5	0,3	35	105	210	53,2	79,5	103,5	4,7	3,0	32 000		HS71906E.2RSD.T.P4S.UL	0,050
	30	47	9	10	0,3	34,0	43,5	0,3	15	45	90	21,0	32,5	44,0	4,9	2,2	43 000		HC71906C.2RSD.T.P4S.UL	0,047
	30	47	9	13	0,3	34,0	43,5	0,3	24	72	144	53,0	78,0	101,5	4,7	2,1	36 000		HC71906E.2RSD.T.P4S.UL	0,047
	30	47	9	10	0,3	34,0	43,5	0,3	21	63	126	21,3	33,5	47,0	4,9	3,2	36 000	53 000	HS71906C.T.P4S.UL	0,050
	30	47	9	13	0,3	34,0	43,5	0,3	35	105	210	53,2	79,5	103,5	4,7	3,0	32 000	48 000	HS71906E.T.P4S.UL	0,050
	30	47	9	10	0,3	34,0	43,5	0,3	15	45	90	21,0	32,5	44,0	4,9	2,2	43 000	63 000	HC71906C.T.P4S.UL	0,047
	30	47	9	13	0,3	34,0	43,5	0,3	24	72	144	53,0	78,0	101,5	4,7	2,1	36 000	53 000	HC71906E.T.P4S.UL	0,047
	30	47	9	10	0,3	34,0	43,5	0,3	15	45	90	21,0	32,5	44,0	7,9	2,2	53 000	80 000	XC71906C.T.P4S.UL	0,047
	30	47	9	13	0,3	34,0	43,5	0,3	24	72	144	53,0	78,0	101,5	7,5	2,1	48 000	70 000	XC71906E.T.P4S.UL	0,047
	30	55	13	12	1,0	36,0	49,0	1,0	29	87	174	24,3	38,8	53,5	6,7	4,3	32 000		HS7006C.2RSD.T.P4S.UL	0,130
	30	55	13	16	1,0	36,0	49,0	1,0	48	144	288	61,0	90,5	118,0	6,3	4,0	28 000		HS7006E.2RSD.T.P4S.UL	0,130
	30	55	13	12	1,0	36,0	49,0	1,0	20	60	120	24,0	37,0	50,0	6,7	3,0	38 000		HC7006C.2RSD.T.P4S.UL	0,125
	30	55	13	16	1,0	36,0	49,0	1,0	33	99	198	60,5	89,5	116,0	6,3	2,8	32 000		HC7006E.2RSD.T.P4S.UL	0,125

12. Measurement tables

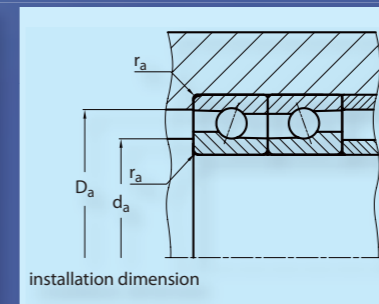
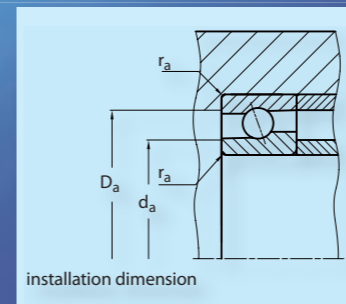
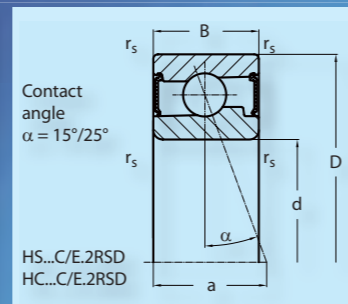
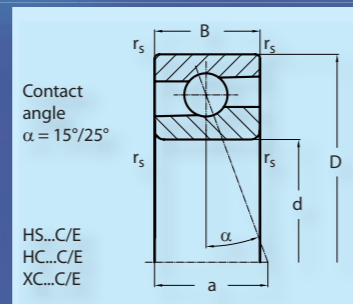

12. Measurement tables

Shaft	dimension (mm)					installation dimension (mm)			preload (N)			axial rigidity (N/μm)			load rating (kN)		speed limit (min ⁻¹)		Code	weight
	d	D	B	a	r _s min	d _a H12	D _a H12	r _a max	L	M	S	L	M	S	dyn C	stat Co	grease	oil	bearing	kg
30	30	55	13	12	1,0	36,0	49,0	1,0	29	87	174	24,3	38,8	53,5	6,7	4,3	32 000	48 000	HS7006C.T.P4S.UL	0,130
	30	55	13	16	1,0	36,0	49,0	1,0	48	144	288	61,0	90,5	118,0	6,3	4,0	28 000	43 000	HS7006E.T.P4S.UL	0,130
	30	55	13	12	1,0	36,0	49,0	1,0	20	60	120	24,0	37,0	50,0	6,7	3,0	38 000	56 000	HC7006C.T.P4S.UL	0,013
	30	55	13	16	1,0	36,0	49,0	1,0	33	99	198	60,5	89,5	116,0	6,3	2,8	32 000	48 000	HC7006E.T.P4S.UL	0,125
	30	55	13	12	1,0	36,0	49,0	1,0	20	60	120	24,0	37,0	50,0	10,7	3,0	50 000	75 000	XC7006C.T.P4S.UL	0,125
	30	55	13	16	1,0	36,0	49,0	1,0	33	99	198	60,5	89,5	116,0	10,1	2,8	40 000	60 000	XC7006E.T.P4S.UL	0,125
35	35	55	10	11	0,6	40,0	51,5	0,6	24	72	144	25,0	39,0	53,5	5,4	3,8	32 000		HS71907C.2RSD.T.P4S.UL	0,080
	35	55	10	16	0,6	40,0	51,5	0,6	38	114	228	61,5	91,5	119,5	5,1	3,6	26 000		HS71907E.2RSD.T.P4S.UL	0,080
	35	55	10	11	0,6	40,0	51,5	0,6	16	48	96	24,0	37,0	50,0	5,4	2,7	36 000		HC71907C.2RSD.T.P4S.UL	0,076
	35	55	10	16	0,6	40,0	51,5	0,6	26	78	156	60,5	90,5	117,0	5,1	2,5	30 000		HC71907E.2RSD.T.P4S.UL	0,076
	35	55	10	11	0,6	40,0	51,5	0,6	24	72	144	25,0	39,0	53,5	5,4	3,8	32 000	48 000	HS71907C.T.P4S.UL	0,080
	35	55	10	16	0,6	40,0	51,5	0,6	38	114	228	61,5	91,5	119,5	5,1	3,6	26 000	40 000	HS71907E.T.P4S.UL	0,080
	35	55	10	11	0,6	40,0	51,5	0,6	16	48	96	24,0	37,0	50,0	5,4	2,7	36 000	53 000	HC71907C.T.P4S.UL	0,076
	35	55	10	16	0,6	40,0	51,5	0,6	26	78	156	60,5	90,5	117,0	5,1	2,5	30 000	45 000	HC71907E.T.P4S.UL	0,076
	35	55	10	11	0,6	40,0	51,5	0,6	16	48	96	24,0	37,0	50,0	8,7	2,7	48 000	70 000	XC71907C.T.P4S.UL	0,076
	35	55	10	16	0,6	40,0	51,5	0,6	26	78	156	60,5	90,5	117,0	8,2	2,5	40 000	60 000	XC71907E.T.P4S.UL	0,076
	35	62	14	14	1,0	41,0	56,0	1,0	32	96	192	27,5	43,0	60,0	7,2	5,0	28 000		HS7007C.2RSD.T.P4S.UL	0,170
	35	62	14	18	1,0	41,0	56,0	1,0	51	153	306	67,5	101,5	132,5	6,8	4,7	24 000		HS7007E.2RSD.T.P4S.UL	0,170
	35	62	14	14	1,0	41,0	56,0	1,0	22	66	132	27,0	41,0	55,5	7,2	3,5	34 000		HC7007C.2RSD.T.P4S.UL	0,164
	35	62	14	18	1,0	41,0	56,0	1,0	36	108	216	68,5	100,5	130,0	6,8	3,3	28 000		HC7007E.2RSD.T.P4S.UL	0,164
	35	62	14	14	1,0	41,0	56,0	1,0	32	96	192	27,5	43,0	60,0	7,2	5,0	28 000	43 000	HS7007C.T.P4S.UL	0,170
	35	62	14	18	1,0	41,0	56,0	1,0	51	153	306	67,5	101,5	132,5	6,8	4,7	24 000	38 000	HS7007E.T.P4S.UL	0,170
	35	62	14	14	1,0	41,0	56,0	1,0	22	66	132	27,0	41,0	55,5	7,2	3,5	34 000	50 000	HC7007C.T.P4S.UL	0,164
	35	62	14	18	1,0	41,0	56,0	1,0	36	108	216	68,5	100,5	130,0	6,8	3,3	28 000	43 000	HC7007E.T.P4S.UL	0,164
35	62	14	14	1,0	41,0	56,0	1,0	22	66	132	27,0	41,0	55,5	11,5	3,5	43 000	63 000	XC7007C.T.P4S.UL	0,164	
35	62	14	18	1,0	41,0	56,0	1,0	36	108	216	68,5	100,5	130,0	10,8	3,3	36 000	53 000	XC7007E.T.P4S.UL	0,164	
40	40	62	12	13	0,6	45,0	58,5	0,6	25	75	150	27,0	42,0	58,0	5,7	4,4	28 000		HS71908C.2RSD.T.P4S.UL	0,130
	40	62	12	18	0,6	45,0	58,5	0,6	40	120	240	67,0	100,0	130,0	5,4	4,1	24 000		HS71908E.2RSD.T.P4S.UL	0,130
	40	62	12	13	0,6	45,0	58,5	0,6	17	51	102	26,5	40,5	54,5	5,7	3,1	32 000		HC71908C.2RSD.T.P4S.UL	0,126
	40	62	12	18	0,6	45,0	58,5	0,6	28	84	168	67,0	99,0	128,0	5,4	2,9	28 000		HC71908E.2RSD.T.P4S.UL	0,160

12. Measurement tables

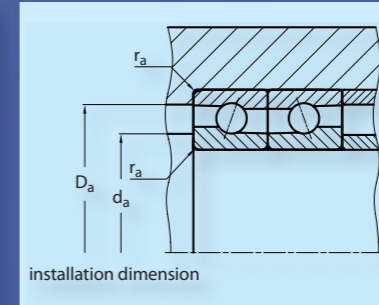
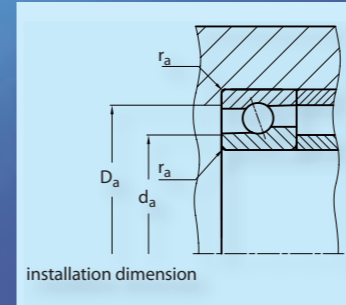
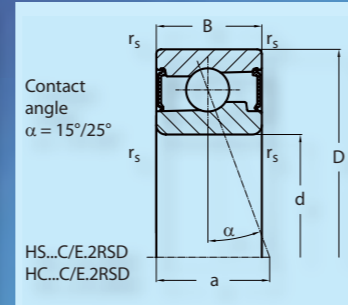
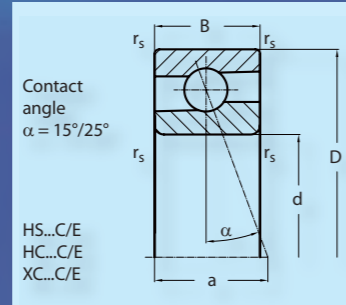

12. Measurement tables

Shaft	dimension (mm)					installation dimension (mm)			preload (N)			axial rigidity (N/μm)			load rating (kN)		speed limit (min ⁻¹)		Code	weight
	d	D	B	a	r _s min	d _a H12	D _a H12	r _a max	L	M	S	L	M	S	dyn C	stat Co	grease	oil	bearing	kg
40	40	62	12	13	0,6	45,0	58,5	0,6	25	75	150	27,0	42,0	58,0	5,7	4,4	28 000	43 000	HS71908C.T.P4S.UL	0,130
	40	62	12	18	0,6	45,0	58,5	0,6	40	120	240	67,0	100,0	130,0	5,4	4,1	24 000	38 000	HS71908E.T.P4S.UL	0,130
	40	62	12	13	0,6	45,0	58,5	0,6	17	51	102	26,5	40,5	54,5	5,7	3,1	32 000	48 000	HC71908C.T.P4S.UL	0,126
	40	62	12	18	0,6	45,0	58,5	0,6	28	84	168	67,0	99,0	128,0	5,4	2,9	28 000	43 000	HC71908E.T.P4S.UL	0,126
	40	62	12	13	0,6	45,0	58,5	0,6	17	51	102	26,5	40,5	54,5	9,1	3,1	40 000	60 000	XC71908C.T.P4S.UL	0,126
	40	62	12	18	0,6	45,0	58,5	0,6	28	84	168	67,0	99,0	128,0	8,6	2,9	36 000	53 000	XC71908E.T.P4S.UL	0,126
	40	68	15	15	1,0	46,0	62,0	1,0	34	102	204	30,0	48,0	65,0	7,6	5,7	26 000		HS7008C.2RSD.T.P4S.UL	0,220
	40	68	15	20	1,0	46,0	62,0	1,0	54	160	324	75,0	112,0	146,0	7,2	5,4	22 000		HS7008E.2RSD.T.P4S.UL	0,220
	40	68	15	15	1,0	46,0	62,0	1,0	23	69	138	29,5	45,5	61,0	7,6	4,0	30 000		HC7008C.2RSD.T.P4S.UL	0,213
	40	68	15	20	1,0	46,0	62,0	1,0	38	114	228	74,8	111,0	143,0	7,2	3,8	26 000		HC7008E.2RSD.T.P4S.UL	0,213
	40	68	15	15	1,0	46,0	62,0	1,0	34	102	204	30,0	48,0	65,0	7,6	5,7	26 000	40 000	HS7008C.T.P4S.UL	0,220
	40	68	15	20	1,0	46,0	62,0	1,0	54	160	324	75,0	112,0	146,0	7,2	5,4	22 000	36 000	HS7008E.T.P4S.UL	0,220
	40	68	15	15	1,0	46,0	62,0	1,0	23	69	138	29,5	45,5	61,0	7,6	4,0	30 000	45 000	HC7008C.T.P4S.UL	0,213
	40	68	15	20	1,0	46,0	62,0	1,0	38	114	228	74,8	111,0	143,0	7,2	3,8	26 000	40 000	HC7008E.T.P4S.UL	0,213
	40	68	15	15	1,0	46,0	62,0	1,0	23	69	138	29,5	45,5	61,0	12,2	4,0	38 000	56 000	XC7008C.T.P4S.UL	0,213
	40	68	15	20	1,0	46,0	62,0	1,0	38	114	228	74,8	111,0	143,0	11,5	3,8	34 000	50 000	XC7008E.T.P4S.UL	0,213
45	45	68	12	14	0,6	50,0	63,5	0,6	34	102	204	31,3	49,0	67,0	7,8	6,0	24 000		HS71909C.2RSD.T.P4S.UL	0,140
	45	68	12	19	0,6	50,0	63,5	0,6	55	165	330	77,7	115,5	151,0	7,4	5,6	22 000		HS71909E.2RSD.T.P4S.UL	0,140
	45	68	12	14	0,6	50,0	63,5	0,6	24	72	144	31,0	47,0	63,0	7,8	4,2	28 000		HC71909C.2RSD.T.P4S.UL	0,133
	45	68	12	19	0,6	50,0	63,5	0,6	38	114	228	77,0	114,0	148,0	7,4	3,9	24 000		HC71909E.2RSD.T.P4S.UL	0,133
	45	68	12	14	0,6	50,0	63,5	0,6	34	102	204	31,3	49,0	67,0	7,8	6,0	24 000	38 000	HS71909C.T.P4S.UL	0,140
	45	68	12	19	0,6	50,0	63,5	0,6	55	165	330	77,7	115,5	151,0	7,4	5,6	22 000	36 000	HS71909E.T.P4S.UL	0,140
	45	68	12	14	0,6	50,0	63,5	0,6	24	72	144	31,0	47,0	63,0	7,8	4,2	28 000	43 000	HC71909C.T.P4S.UL	0,133
	45	68	12	19	0,6	50,0	63,5	0,6	38	114	228	77,0	114,0	148,0	7,4	3,9	24 000	38 000	HC71909E.T.P4S.UL	0,133
	45	68	12	14	0,6	50,0	63,5	0,6	24	72	144	31,0	47,0	63,0	12,5	4,2	38 000	56 000	XC71909C.T.P4S.UL	0,133
	45	68	12	19	0,6	50,0	63,5	0,6	38	114	228	77,0	114,0	148,0	11,8	3,9	32 000	48 000	XC71909E.T.P4S.UL	0,133
	45	75	16	16	1,0	51,0	69,0	1,0	44	132	264	34,0	54,0	75,0	10,0	7,5	24 000		HS7009C.2RSD.T.P4S.UL	0,270
	45	75	16	22	1,0	51,0	69,0	1,0	71	213	426	86,0	128,0	168,0	9,4	7,1	20 000		HS7009E.2RSD.T.P4S.UL	0,270
	45	75	16	16	1,0	51,0	69,0	1,0	30	90	180	33,5	52,0	70,0	10,0	5,3	26 000		HC7009C.2RSD.T.P4S.UL	0,260
	45	75	16	22	1,0	51,0	69,0	1,0	49	147	294	85,0	126,0	163,5	9,4	5,0	24 000		HC7009E.2RSD.T.P4S.UL	0,260

12. Measurement tables

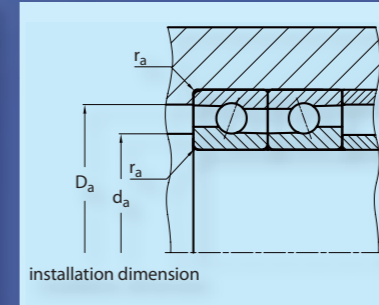
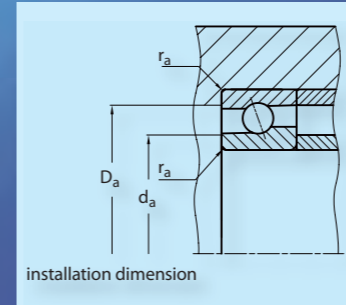
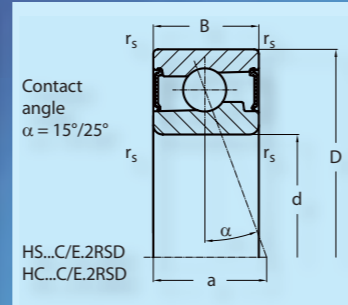
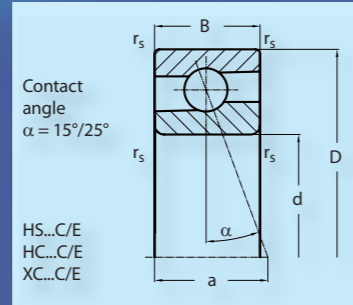

12. Measurement tables

Shaft	dimension (mm)					installation dimension (mm)			preload (N)			axial rigidity (N/μm)			load rating (kN)		speed limit (min ⁻¹)		Code	weight
	d	D	B	a	r _s min	d _a H12	D _a H12	r _a max	L	M	S	L	M	S	dyn C	stat Co	grease	oil	bearing	kg
45	45	75	16	16	1,0	51,0	69,0	1,0	44	132	264	34,0	54,0	75,0	10,0	7,5	24 000	38 000	HS7009C.T.P4S.UL	0,270
	45	75	16	22	1,0	51,0	69,0	1,0	71	213	426	86,0	128,0	168,0	9,4	7,1	20 000	34 000	HS7009E.T.P4S.UL	0,270
	45	75	16	16	1,0	51,0	69,0	1,0	30	90	180	33,5	52,0	70,0	10,0	5,3	26 000	40 000	HC7009C.T.P4S.UL	0,260
	45	75	16	22	1,0	51,0	69,0	1,0	49	147	294	85,0	126,0	163,5	9,4	5,0	24 000	38 000	HC7009E.T.P4S.UL	0,260
	45	75	16	16	1,0	51,0	69,0	1,0	30	90	180	33,5	52,0	70,0	15,9	5,3	34 000	50 000	XC7009C.T.P4S.UL	0,260
	45	75	16	22	1,0	51,0	69,0	1,0	49	147	294	85,0	126,0	163,5	15,1	5,0	30 000	45 000	XC7009E.T.P4S.UL	0,260
50	50	72	12	14	0,6	55,0	67,5	0,6	35	105	210	33,0	51,0	70,0	8,1	6,5	22 000		HS71910C.2RSD.T.P4S.UL	0,150
	50	72	12	20	0,6	55,0	67,5	0,6	58	174	348	82,0	122,0	160,0	7,6	6,1	20 000		HS71910E.2RSD.T.P4S.UL	0,150
	50	72	12	14	0,6	55,0	67,5	0,6	24	72	144	32,0	49,0	66,0	8,1	4,5	26 000		HC71910C.2RSD.T.P4S.UL	0,142
	50	72	12	20	0,6	55,0	67,5	0,6	39	117	234	81,7	120,0	156,0	7,6	4,3	22 000		HC71910E.2RSD.T.P4S.UL	0,142
	50	72	12	14	0,6	55,0	67,5	0,6	35	105	210	33,0	51,0	70,0	8,1	6,5	22 000	36 000	HS71910C.T.P4S.UL	0,150
	50	72	12	20	0,6	55,0	67,5	0,6	58	174	348	82,0	122,0	160,0	7,6	6,1	20 000	34 000	HS71910E.T.P4S.UL	0,150
	50	72	12	14	0,6	55,0	67,5	0,6	24	72	144	32,0	49,0	66,0	8,1	4,5	26 000	40 000	HC71910C.T.P4S.UL	0,142
	50	72	12	20	0,6	55,0	67,5	0,6	39	117	234	81,7	120,0	156,0	7,6	4,3	22 000	36 000	HC71910E.T.P4S.UL	0,142
	50	72	12	14	0,6	55,0	67,5	0,6	24	72	144	32,0	49,0	66,0	12,9	4,5	34 000	50 000	XC71910C.T.P4S.UL	0,142
	50	72	12	20	0,6	55,0	67,5	0,6	39	117	234	81,7	120,0	156,0	12,2	4,3	30 000	45 000	XC71910E.T.P4S.UL	0,142
	50	80	16	17	1,0	56,0	74,0	1,0	46	138	276	37,0	58,0	79,5	10,3	8,2	22 000		HS7010C.2RSD.T.P4S.UL	0,290
	50	80	16	23	1,0	56,0	74,0	1,0	74	222	444	91,0	136,0	178,0	9,8	7,7	18 000		HS7010E.2RSD.T.P4S.UL	0,290
	50	80	16	17	1,0	56,0	74,0	1,0	32	96	192	36,0	55,0	75,0	10,3	5,7	24 000		HC7010C.2RSD.T.P4S.UL	0,279
	50	80	16	23	1,0	56,0	74,0	1,0	51	153	306	91,5	134,5	174,0	9,8	5,4	22 000		HC7010E.2RSD.T.P4S.UL	0,279
	50	80	16	17	1,0	56,0	74,0	1,0	46	138	276	37,0	58,0	79,5	10,3	8,2	22 000	36 000	HS7010C.T.P4S.UL	0,290
	50	80	16	23	1,0	56,0	74,0	1,0	74	222	444	91,0	136,0	178,0	9,8	7,7	18 000	30 000	HS7010E.T.P4S.UL	0,290
	50	80	16	17	1,0	56,0	74,0	1,0	32	96	192	36,0	55,0	75,0	10,3	5,7	24 000	38 000	HC7010C.T.P4S.UL	0,279
	50	80	16	23	1,0	56,0	74,0	1,0	51	153	306	91,5	134,5	174,0	9,8	5,4	22 000	36 000	HC7010E.T.P4S.UL	0,279
50	80	16	17	1,0	56,0	74,0	1,0	32	96	192	36,0	55,0	75,0	16,5	5,7	32 000	48 000	XC7010C.T.P4S.UL	0,279	
50	80	16	23	1,0	56,0	74,0	1,0	51	153	306	91,5	134,5	174,0	15,6	5,4	28 000	43 000	XC7010E.T.P4S.UL	0,279	
55	55	80	13	16	1,0	60,0	75,5	0,6	46	138	276	38,0	59,0	82,0	10,4	8,5	20 000		HS71911C.2RSD.T.P4S.UL	0,200
	55	80	13	22	1,0	60,0	75,5	0,6	75	225	450	94,0	140,0	183,0	9,8	8,1	18 000		HS71911E.2RSD.T.P4S.UL	0,200
	55	80	13	16	1,0	60,0	75,5	0,6	32	96	192	37,0	57,0	77,0	10,4	6,0	24 000		HC71911C.2RSD.T.P4S.UL	0,188
	55	80	13	22	1,0	60,0	75,5	0,6	52	156	312	93,5	138,5	179,5	9,8	5,6	20 000		HC71911E.2RSD.T.P4S.UL	0,188

12. Measurement tables

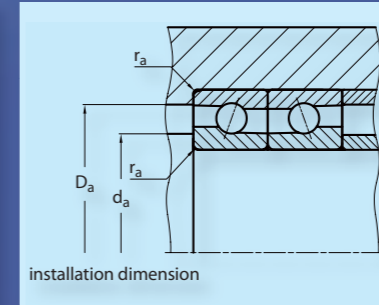
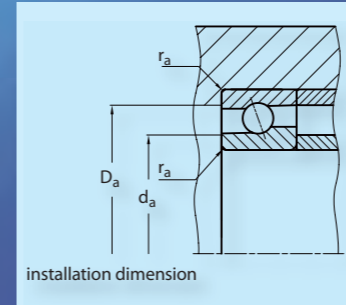
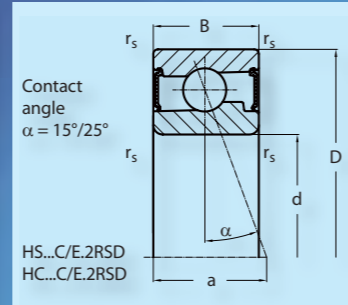
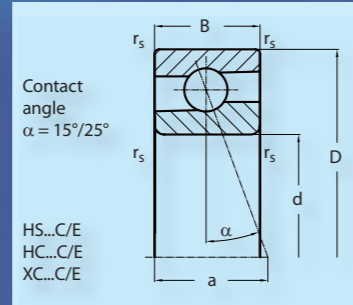

12. Measurement tables

Shaft	dimension (mm)					installation dimension (mm)			preload (N)			axial rigidity (N/μm)			load rating (kN)		speed limit (min ⁻¹)		Code	weight
	d	D	B	a	r _s min	d _a H12	D _a H12	r _a max	L	M	S	L	M	S	dyn C	stat Co	grease	oil	bearing	kg
55	55	80	13	16	1,0	60,0	75,5	0,6	46	138	276	38,0	59,0	82,0	10,4	8,5	20 000	34 000	HS71911C.T.P4S.UL	0,200
	55	80	13	22	1,0	60,0	75,5	0,6	75	225	450	94,0	140,0	183,0	9,8	8,1	18 000	30 000	HS71911E.T.P4S.UL	0,200
	55	80	13	16	1,0	60,0	75,5	0,6	32	96	192	37,0	57,0	77,0	10,4	6,0	24 000	38 000	HC71911C.T.P4S.UL	0,188
	55	80	13	22	1,0	60,0	75,5	0,6	52	156	312	93,5	138,5	179,5	9,8	5,6	20 000	34 000	HC71911E.T.P4S.UL	0,188
	55	80	13	16	1,0	60,0	75,5	0,6	32	96	192	37,0	57,0	77,0	16,6	6,0	32 000	48 000	XC71911C.T.P4S.UL	0,188
	55	80	13	22	1,0	60,0	75,5	0,6	52	156	312	93,5	138,5	179,5	15,7	5,6	26 000	40 000	XC71911E.T.P4S.UL	0,188
	55	90	18	19	1,1	62,0	83,0	1,0	64	192	384	42,5	67,0	92,5	14,4	11,5	19 000		HS7011C.2RSD.T.P4S.UL	0,430
	55	90	18	26	1,1	62,0	83,0	1,0	105	315	630	105,0	160,0	208,0	13,6	10,9	17 000		HS7011E.2RSD.T.P4S.UL	0,430
	55	90	18	19	1,1	62,0	83,0	1,0	45	135	270	42,0	65,0	87,0	14,4	8,0	22 000		HC7011C.2RSD.T.P4S.UL	0,411
	55	90	18	26	1,1	62,0	83,0	1,0	73	220	438	107,0	158,0	204,0	13,6	7,6	19 000		HC7011E.2RSD.T.P4S.UL	0,411
	55	90	18	19	1,1	62,0	83,0	1,0	64	192	384	42,5	67,0	92,5	14,4	11,5	19 000	32 000	HS7011C.T.P4S.UL	0,430
	55	90	18	26	1,1	62,0	83,0	1,0	105	315	630	105,0	160,0	208,0	13,6	10,9	17 000	28 000	HS7011E.T.P4S.UL	0,430
	55	90	18	19	1,1	62,0	83,0	1,0	45	135	270	42,0	65,0	87,0	14,4	8,0	22 000	36 000	HC7011C.T.P4S.UL	0,411
	55	90	18	26	1,1	62,0	83,0	1,0	73	220	438	107,0	158,0	204,0	13,6	7,6	19 000	32 000	HC7011E.T.P4S.UL	0,411
	55	90	18	19	1,1	62,0	83,0	1,0	45	135	270	42,0	65,0	87,0	23,0	8,0	28 000	43 000	XC7011C.T.P4S.UL	0,411
	55	90	18	26	1,1	62,0	83,0	1,0	73	220	438	107,0	158,0	204,0	21,8	7,6	24 000	38 000	XC7011E.T.P4S.UL	0,411
60	60	85	13	16	1,0	65,0	80,5	0,6	48	144	288	40,0	63,0	86,0	10,7	9,2	19 000		HS71912C.2RSD.T.P4S.UL	0,210
	60	85	13	23	1,0	65,0	80,5	0,6	78	234	468	100,0	150,0	194,0	10,1	8,7	17 000		HS71912E.2RSD.T.P4S.UL	0,210
	60	85	13	16	1,0	65,0	80,5	0,6	34	102	204	39,5	60,5	81,0	10,7	6,4	22 000		HC71912C.2RSD.T.P4S.UL	0,198
	60	85	13	23	1,0	65,0	80,5	0,6	53	159	318	99,0	146,0	189,0	10,1	6,1	19 000		HC71912E.2RSD.T.P4S.UL	0,198
	60	85	13	16	1,0	65,0	80,5	0,6	48	144	288	40,0	63,0	86,0	10,7	9,2	19 000	32 000	HS71912C.T.P4S.UL	0,210
	60	85	13	23	1,0	65,0	80,5	0,6	78	234	468	100,0	150,0	194,0	10,1	8,7	17 000	28 000	HS71912E.T.P4S.UL	0,210
	60	85	13	16	1,0	65,0	80,5	0,6	34	102	204	39,5	60,5	81,0	10,7	6,4	22 000	36 000	HC71912C.T.P4S.UL	0,198
	60	85	13	23	1,0	65,0	80,5	0,6	53	159	318	99,0	146,0	189,0	10,1	6,1	19 000	32 000	HC71912E.T.P4S.UL	0,198
	60	85	13	16	1,0	65,0	80,5	0,6	34	102	204	39,5	60,5	81,0	17,2	6,4	28 000	43 000	XC71912C.T.P4S.UL	0,198
	60	85	13	23	1,0	65,0	80,5	0,6	53	159	318	99,0	146,0	189,0	16,2	6,1	24 000	38 000	XC71912E.T.P4S.UL	0,198
	60	95	18	19	1,1	67,0	88,0	1,0	67	201	402	45,0	71,5	98,0	15,0	12,5	18 000		HS7012C.2RSD.T.P4S.UL	0,460
	60	95	18	27	1,1	67,0	88,0	1,0	107	321	642	113,0	168,0	220,0	14,1	11,8	15 000		HS7012E.2RSD.T.P4S.UL	0,460
	60	95	18	19	1,1	67,0	88,0	1,0	46	138	276	44,0	68,5	92,5	15,0	8,7	20 000		HC7012C.2RSD.T.P4S.UL	0,439
	60	95	18	27	1,1	67,0	88,0	1,0	75	225	450	112,0	166,0	216,0	14,1	8,3	18 000		HC7012E.2RSD.T.P4S.UL	0,439

12. Measurement tables

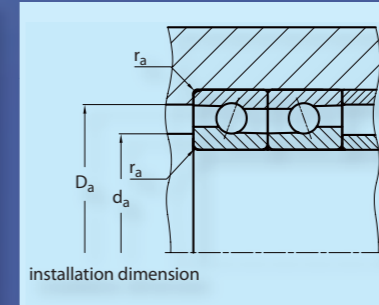
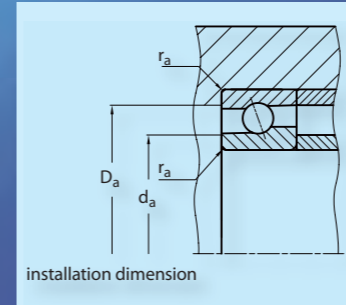
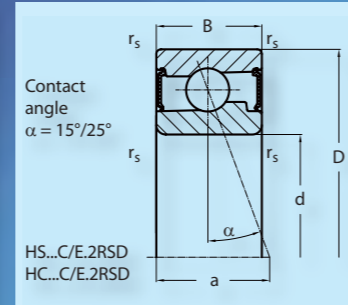
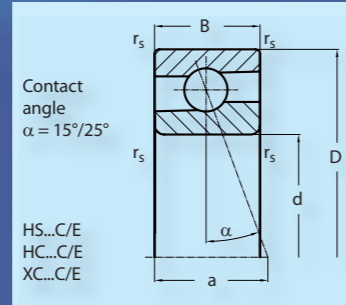

12. Measurement tables

Shaft	dimension (mm)					installation dimension (mm)			preload (N)			axial rigidity (N/μm)			load rating (kN)		speed limit (min ⁻¹)		Code	weight
	d	D	B	a	r _s min	d _a H12	D _a H12	r _a max	L	M	S	L	M	S	dyn C	stat Co	grease	oil	bearing	kg
60	60	95	18	19	1,1	67,0	88,0	1,0	67	201	402	45,0	71,5	98,0	15,0	12,5	18 000	30 000	HS7012C.T.P4S.UL	0,460
	60	95	18	27	1,1	67,0	88,0	1,0	107	321	642	113,0	168,0	220,0	14,1	11,8	15 000	24 000	HS7012E.T.P4S.UL	0,460
	60	95	18	19	1,1	67,0	88,0	1,0	46	138	276	44,0	68,5	92,5	15,0	8,7	20 000	34 000	HC7012C.T.P4S.UL	0,439
	60	95	18	27	1,1	67,0	88,0	1,0	75	225	450	112,0	166,0	216,0	14,1	8,3	18 000	30 000	HC7012E.T.P4S.UL	0,439
	60	95	18	19	1,1	67,0	88,0	1,0	46	138	276	44,0	68,5	92,5	23,9	8,7	28 000	43 000	XC7012C.T.P4S.UL	0,439
	60	95	18	27	1,1	67,0	88,0	1,0	75	225	450	112,0	166,0	216,0	22,6	8,3	24 000	38 000	XC7012E.T.P4S.UL	0,439
65	65	90	13	17	1,0	70,0	85,5	0,6	49	147	294	41,5	65,5	90,0	11,0	9,9	18 000		HS71913C.2RSD.T.P4S.UL	0,230
	65	90	13	25	1,0	70,0	85,5	0,6	80	240	480	105,0	156,0	202,0	10,4	9,3	15 000		HS71913E.2RSD.T.P4S.UL	0,230
	65	90	13	17	1,0	70,0	85,5	0,6	34	102	204	41,0	63,0	85,0	11,0	6,9	20 000		HC71913C.2RSD.T.P4S.UL	0,217
	65	90	13	25	1,0	70,0	85,5	0,6	55	165	330	104,0	154,0	199,0	10,4	6,5	18 000		HC71913E.2RSD.T.P4S.UL	0,217
	65	90	13	17	1,0	70,0	85,5	0,6	49	147	294	41,5	65,5	90,0	11,0	9,9	18 000	30 000	HS71913C.T.P4S.UL	0,230
	65	90	13	25	1,0	70,0	85,5	0,6	80	240	480	105,0	156,0	202,0	10,4	9,3	15 000	24 000	HS71913E.T.P4S.UL	0,230
	65	90	13	17	1,0	70,0	85,5	0,6	34	102	204	41,0	63,0	85,0	11,0	6,9	20 000	34 000	HC71913C.T.P4S.UL	0,217
	65	90	13	25	1,0	70,0	85,5	0,6	55	165	330	104,0	154,0	199,0	10,4	6,5	18 000	30 000	HC71913E.T.P4S.UL	0,217
	65	90	13	17	1,0	70,0	85,5	0,6	34	102	204	41,0	63,0	85,0	17,6	6,9	26 000	43 000	XC71913C.T.P4S.UL	0,217
	65	90	13	25	1,0	70,0	85,5	0,6	55	165	330	104,0	154,0	199,0	16,6	6,5	24 000	38 000	XC71913E.T.P4S.UL	0,217
	65	100	18	20	1,1	72,0	93,0	1,0	70	210	420	48,0	76,0	104,0	15,5	13,5	17 000		HS7013C.2RSD.T.P4S.UL	0,480
	65	100	18	28	1,1	72,0	93,0	1,0	112	336	672	120,0	178,0	233,0	14,6	12,7	15 000		HS7013E.2RSD.T.P4S.UL	0,480
	65	100	18	20	1,1	72,0	93,0	1,0	47	141	282	46,0	72,0	97,0	15,5	9,4	20 000		HC7013C.2RSD.T.P4S.UL	0,458
	65	100	18	28	1,1	72,0	93,0	1,0	77	231	462	119,0	176,0	225,0	14,6	8,9	17 000		HC7013E.2RSD.T.P4S.UL	0,458
	65	100	18	20	1,1	72,0	93,0	1,0	70	210	420	48,0	76,0	104,0	15,5	13,5	17 000	28 000	HS7013C.T.P4S.UL	0,480
	65	100	18	28	1,1	72,0	93,0	1,0	112	336	672	120,0	178,0	233,0	14,6	12,7	15 000	24 000	HS7013E.T.P4S.UL	0,480
	65	100	18	20	1,1	72,0	93,0	1,0	47	141	282	46,0	72,0	97,0	15,5	9,4	20 000	34 000	HC7013C.T.P4S.UL	0,458
	65	100	18	28	1,1	72,0	93,0	1,0	77	231	462	119,0	176,0	225,0	14,6	8,9	17 000	28 000	HC7013E.T.P4S.UL	0,458
65	100	18	20	1,1	72,0	93,0	1,0	47	141	282	46,0	72,0	97,0	24,7	9,4	26 000	40 000	XC7013C.T.P4S.UL	0,458	
65	100	18	28	1,1	72,0	93,0	1,0	77	231	462	119,0	176,0	225,0	23,3	8,9	22 000	36 000	XC7013E.T.P4S.UL	0,458	
70	70	100	16	19	1,0	76,0	94,5	0,6	64	192	384	48,0	75,0	103,0	14,3	12,9	16 000		HS71914C.2RSD.T.P4S.UL	0,370
	70	100	16	28	1,0	76,0	94,5	0,6	103	309	618	120,0	177,0	230,0	13,4	12,2	14 000		HS71914E.2RSD.T.P4S.UL	0,370
	70	100	16	19	1,0	76,0	94,5	0,6	44	132	264	47,0	72,0	96,0	14,3	9,1	19 000		HC71914C.2RSD.T.P4S.UL	0,350
	70	100	16	28	1,0	76,0	94,5	0,6	71	213	426	118,0	175,0	227,0	13,4	8,6	16 000		HC71914E.2RSD.T.P4S.UL	0,350

12. Measurement tables

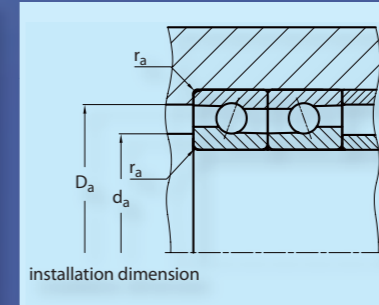
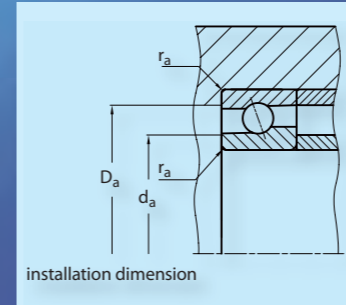
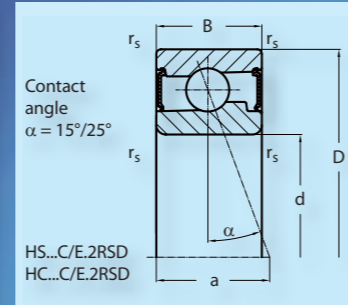
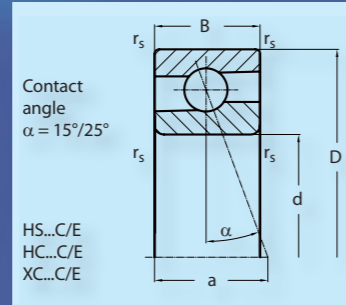

12. Measurement tables

Shaft	dimension (mm)					installation dimension (mm)			preload (N)			axial rigidity (N/μm)			load rating (kN)		speed limit (min ⁻¹)		Code	weight
	d	D	B	a	r _s min	d _a H12	D _a H12	r _a max	L	M	S	L	M	S	dyn C	stat Co	grease	oil	bearing	kg
70	70	100	16	19	1,0	76,0	94,5	0,6	64	192	384	48,0	75,0	103,0	14,3	12,9	16 000	26 000	HS71914C.T.P4S.UL	0,370
	70	100	16	28	1,0	76,0	94,5	0,6	103	309	618	120,0	177,0	230,0	13,4	12,2	14 000	22 000	HS71914E.T.P4S.UL	0,370
	70	100	16	19	1,0	76,0	94,5	0,6	44	132	264	47,0	72,0	96,0	14,3	9,1	19 000	32 000	HC71914C.T.P4S.UL	0,350
	70	100	16	28	1,0	76,0	94,5	0,6	71	213	426	118,0	175,0	227,0	13,4	8,6	16 000	26 000	HC71914E.T.P4S.UL	0,350
	70	100	16	19	1,0	76,0	94,5	0,6	44	132	264	47,0	72,0	96,0	22,8	9,1	24 000	40 000	XC71914C.T.P4S.UL	0,350
	70	100	16	28	1,0	76,0	94,5	0,6	71	213	426	118,0	175,0	227,0	21,5	8,6	22 000	36 000	XC71914E.T.P4S.UL	0,350
	70	110	20	22	1,1	77,0	102,0	1,0	89	267	534	53,0	82,5	114,0	20,0	17,2	16 000		HS7014C.2RSD.T.P4S.UL	0,670
	70	110	20	31	1,1	77,0	102,0	1,0	146	438	876	132,0	197,0	257,0	18,9	16,3	13 000		HS7014E.2RSD.T.P4S.UL	0,670
	70	110	20	22	1,1	77,0	102,0	1,0	63	189	378	52,0	80,0	107,5	20,0	12,1	18 000		HC7014C.2RSD.T.P4S.UL	0,636
	70	110	20	31	1,1	77,0	102,0	1,0	101	303	606	131,6	195,0	252,0	18,9	11,4	15 000		HC7014E.2RSD.T.P4S.UL	0,636
	70	110	20	22	1,1	77,0	102,0	1,0	89	267	534	53,0	82,5	114,0	20,0	17,2	16 000	26 000	HS7014C.T.P4S.UL	0,670
	70	110	20	31	1,1	77,0	102,0	1,0	146	438	876	132,0	197,0	257,0	18,9	16,3	13 000	20 000	HS7014E.T.P4S.UL	0,670
	70	110	20	22	1,1	77,0	102,0	1,0	63	189	378	52,0	80,0	107,5	20,0	12,1	18 000	30 000	HC7014C.T.P4S.UL	0,636
	70	110	20	31	1,1	77,0	102,0	1,0	101	303	606	131,6	195,0	252,0	18,9	11,4	15 000	24 000	HC7014E.T.P4S.UL	0,636
	70	110	20	22	1,1	77,0	102,0	1,0	63	189	378	52,0	80,0	107,5	32,0	12,1	24 000	38 000	XC7014C.T.P4S.UL	0,636
	70	110	20	31	1,1	77,0	102,0	1,0	101	303	606	131,6	195,0	252,0	30,3	11,4	20 000	34 000	XC7014E.T.P4S.UL	0,636
75	75	105	16	20	1,0	81,0	99,5	0,6	65	195	390	50,1	78,2	106,8	14,7	13,8	16 000		HS71915C.2RSD.T.P4S.UL	0,400
	75	105	16	29	1,0	81,0	99,5	0,6	105	310	630	125,0	185,0	240,5	13,8	13,0	13 000		HS71915E.2RSD.T.P4S.UL	0,400
	75	105	16	20	1,0	81,0	99,5	0,6	45	133	265	48,6	75,1	100,6	14,7	9,7	18 000		HC71915C.2RSD.T.P4S.UL	0,379
	75	105	16	29	1,0	81,0	99,5	0,6	72	220	435	124,5	185,4	238,0	13,8	9,1	15 000		HC71915E.2RSD.T.P4S.UL	0,379
	75	105	16	20	1,0	81,0	99,5	0,6	65	195	390	50,1	78,2	106,8	14,7	13,8	16 000	26 000	HS71915C.T.P4S.UL	0,400
	75	105	16	29	1,0	81,0	99,5	0,6	105	310	630	125,0	185,0	240,5	13,8	13,0	13 000	20 000	HS71915E.T.P4S.UL	0,400
	75	105	16	20	1,0	81,0	99,5	0,6	45	133	265	48,6	75,1	100,6	14,7	9,7	18 000	30 000	HC71915C.T.P4S.UL	0,379
	75	105	16	29	1,0	81,0	99,5	0,6	72	220	435	124,5	185,4	238,0	13,8	9,1	15 000	24 000	HC71915E.T.P4S.UL	0,379
	75	105	16	20	1,0	81,0	99,5	0,6	45	133	265	48,6	75,1	100,6	23,4	9,7	23 000	40 000	XC71915C.T.P4S.UL	0,379
	75	105	16	29	1,0	81,0	99,5	0,6	72	220	435	124,5	185,4	238,0	22,1	9,1	19 000	32 000	XC71915E.T.P4S.UL	0,379
	75	115	20	23	1,1	82,0	107,0	1,0	91	273	546	55,0	86,0	117,0	20,3	17,9	15 000		HS7015C.2RSD.T.P4S.UL	0,710
	75	115	20	32	1,1	82,0	107,0	1,0	148	444	888	136,0	202,0	262,0	19,1	17,0	13 000		HS7015E.2RSD.T.P4S.UL	0,710
	75	115	20	23	1,1	82,0	107,0	1,0	64	192	378	54,0	82,0	110,0	20,3	12,6	17 000		HC7015C.2RSD.T.P4S.UL	0,675
	75	115	20	32	1,1	82,0	107,0	1,0	102	306	610	134,0	199,0	257,0	19,1	11,9	15 000		HC7015E.2RSD.T.P4S.UL	0,675

12. Measurement tables

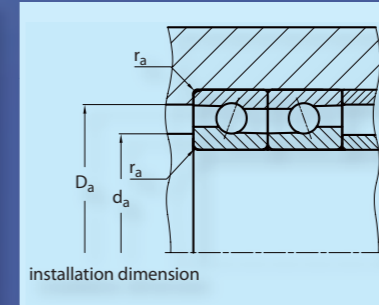
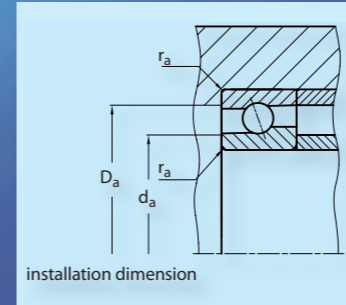
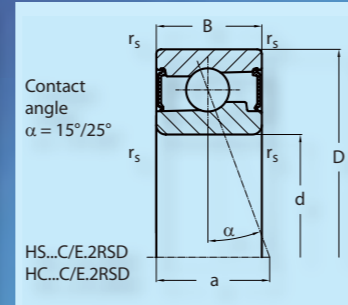
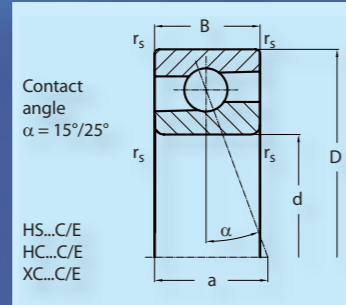

12. Measurement tables

Shaft	dimension (mm)					installation dimension (mm)			preload (N)			axial rigidity (N/μm)			load rating (kN)		speed limit (min ⁻¹)		Code	weight
	d	D	B	a	r _s min	d _a H12	D _a H12	r _a max	L	M	S	L	M	S	dyn C	stat Co	grease	oil	bearing	kg
75	75	115	20	23	1,1	82,0	107,0	1,0	91	273	546	55,0	86,0	117,0	20,3	17,9	15 000	24 000	HS7015C.T.P4S.UL	0,710
	75	115	20	32	1,1	82,0	107,0	1,0	148	444	888	136,0	202,0	262,0	19,1	17,0	13 000	20 000	HS7015E.T.P4S.UL	0,710
	75	115	20	23	1,1	82,0	107,0	1,0	64	192	378	54,0	82,0	110,0	20,3	12,6	17 000	28 000	HC7015C.T.P4S.UL	0,675
	75	115	20	32	1,1	82,0	107,0	1,0	102	306	610	134,0	199,0	257,0	19,1	11,9	15 000	24 000	HC7015E.T.P4S.UL	0,675
	75	115	20	23	1,1	82,0	107,0	1,0	64	192	378	54,0	82,0	110,0	32,5	12,6	22 000	36 000	XC7015C.T.P4S.UL	0,675
	75	115	20	32	1,1	82,0	107,0	1,0	102	306	610	134,0	199,0	257,0	30,6	11,9	19 000	32 000	XC7015E.T.P4S.UL	0,675
80	80	110	16	21	1,0	86,0	104,0	0,6	73	219	438	53,0	83,0	113,0	16,3	15,5	15 000		HS71916C.2RSD.T.P4S.UL	0,410
	80	110	16	30	1,0	86,0	104,0	0,6	117	351	702	132,0	196,0	256,0	15,4	14,6	13 000		HS71916E.2RSD.T.P4S.UL	0,410
	80	110	16	21	1,0	86,0	104,0	0,6	50	150	300	52,0	79,0	106,0	16,3	10,8	17 000		HC71916C.2RSD.T.P4S.UL	0,385
	80	110	16	30	1,0	86,0	104,0	0,6	81	243	486	130,0	194,0	251,0	15,4	10,2	15 000		HC71916E.2RSD.T.P4S.UL	0,385
	80	110	16	21	1,0	86,0	104,0	0,6	73	219	438	53,0	83,0	113,0	16,3	15,5	15 000	24 000	HS71916C.T.P4S.UL	0,410
	80	110	16	30	1,0	86,0	104,0	0,6	117	351	702	132,0	196,0	256,0	15,4	14,6	13 000	20 000	HS71916E.T.P4S.UL	0,410
	80	110	16	21	1,0	86,0	104,0	0,6	50	150	300	52,0	79,0	106,0	16,3	10,8	17 000	28 000	HC71916C.T.P4S.UL	0,385
	80	110	16	30	1,0	86,0	104,0	0,6	81	243	486	130,0	194,0	251,0	15,4	10,2	15 000	24 000	HC71916E.T.P4S.UL	0,385
	80	110	16	21	1,0	86,0	104,0	0,6	50	150	300	52,0	79,0	106,0	26,1	10,8	22 000	36 000	XC71916C.T.P4S.UL	0,385
	80	110	16	30	1,0	86,0	104,0	0,6	81	243	486	130,0	194,0	251,0	24,6	10,2	19 000	32 000	XC71916E.T.P4S.UL	0,385
	80	125	22	25	1,1	88,0	117,0	1,0	109	327	654	59,0	93,0	128,0	24,4	21,8	14 000		HS7016C.2RSD.T.P4S.UL	0,960
	80	125	22	35	1,1	88,0	117,0	1,0	175	525	1050	148,0	220,0	288,0	23,1	20,6	12 000		HS7016E.2RSD.T.P4S.UL	0,960
	80	125	22	25	1,1	88,0	117,0	1,0	74	222	444	57,0	88,0	119,0	24,4	15,2	16 000		HC7016C.2RSD.T.P4S.UL	0,915
	80	125	22	35	1,1	88,0	117,0	1,0	123	369	738	147,0	218,0	283,0	23,1	14,4	13 000		HC7016E.2RSD.T.P4S.UL	0,192
	80	125	22	25	1,1	88,0	117,0	1,0	109	327	654	59,0	93,0	128,0	24,4	21,8	14 000	22 000	HS7016C.T.P4S.UL	0,960
	80	125	22	35	1,1	88,0	117,0	1,0	175	525	1050	148,0	220,0	288,0	23,1	20,6	12 000	19 000	HS7016E.T.P4S.UL	0,960
	80	125	22	25	1,1	88,0	117,0	1,0	74	222	444	57,0	88,0	119,0	24,4	15,2	16 000	26 000	HC7016C.T.P4S.UL	0,915
	80	125	22	35	1,1	88,0	117,0	1,0	123	369	738	147,0	218,0	283,0	23,1	14,4	13 000	20 000	HC7016E.T.P4S.UL	0,915
80	125	22	25	1,1	88,0	117,0	1,0	74	222	444	57,0	88,0	119,0	39,1	15,2	20 000	34 000	XC7016C.T.P4S.UL	0,915	
80	125	22	35	1,1	88,0	117,0	1,0	123	369	738	147,0	218,0	283,0	36,9	14,4	17 000	28 000	XC7016E.T.P4S.UL	0,915	
85	85	120	18	23	1,1	92,0	114,0	0,6	76	228	456	58,0	89,0	121,0	17,0	17,0	14 000		HS71917C.2RSD.T.P4S.UL	0,610
	85	120	18	33	1,1	92,0	114,0	0,6	123	369	738	142,0	210,0	274,0	16,0	16,0	12 000		HS71917E.2RSD.T.P4S.UL	0,610
	85	120	18	23	1,1	92,0	114,0	0,6	53	159	318	56,0	85,0	115,0	17,0	11,9	16 000		HC71917C.2RSD.T.P4S.UL	0,582
	85	120	18	33	1,1	92,0	114,0	0,6	84	252	504	141,0	207,5	269,0	16,0	11,2	13 000		HC71917E.2RSD.T.P4S.UL	0,582

12. Measurement tables

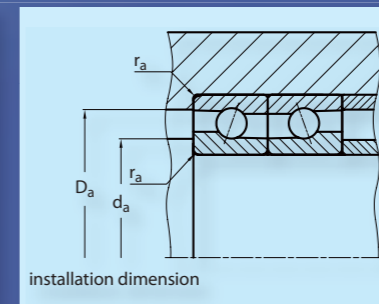
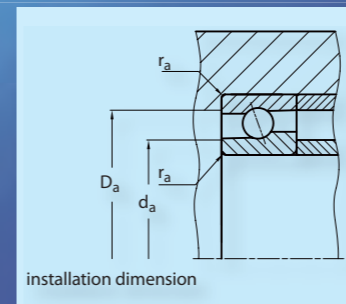
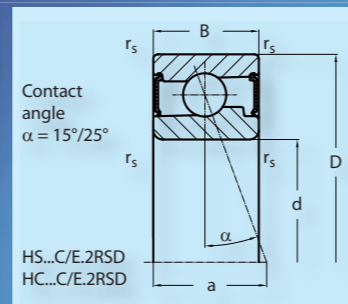
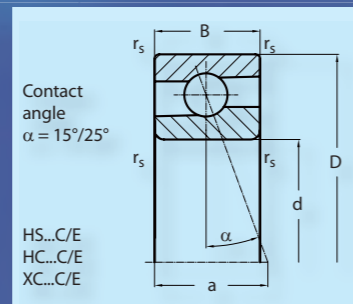

12. Measurement tables

Shaft	dimension (mm)					installation dimension (mm)			preload (N)			axial rigidity (N/μm)			load rating (kN)		speed limit (min ⁻¹)		Code	weight
	d	D	B	a	r _s min	d _a H12	D _a H12	r _a max	L	M	S	L	M	S	dyn C	stat Co	grease	oil	bearing	kg
85	85	120	18	23	1,1	92,0	114,0	0,6	76	228	456	58,0	89,0	121,0	17,0	17,0	14 000	22 000	HS71917C.T.P4S.UL	0,610
	85	120	18	33	1,1	92,0	114,0	0,6	123	369	738	142,0	210,0	274,0	16,0	16,0	12 000	19 000	HS71917E.T.P4S.UL	0,610
	85	120	18	23	1,1	92,0	114,0	0,6	53	159	318	56,0	85,0	115,0	17,0	11,9	16 000	26 000	HC71917C.T.P4S.UL	0,582
	85	120	18	33	1,1	92,0	114,0	0,6	84	252	504	141,0	207,5	269,0	16,0	11,2	13 000	20 000	HC71917E.T.P4S.UL	0,582
	85	120	18	23	1,1	92,0	114,0	0,6	53	159	318	56,0	85,0	115,0	27,1	11,9	20 000	34 000	XC71917C.T.P4S.UL	0,582
	85	120	18	33	1,1	92,0	114,0	0,6	84	252	504	141,0	207,5	269,0	25,6	11,2	17 000	28 000	XC71917E.T.P4S.UL	0,582
	85	130	22	25	1,1	93,0	122,0	1,0	109	327	654	61,0	95,0	130,0	24,6	22,6	13 000		HS7017C.2RSD.T.P4S.UL	0,990
	85	130	22	36	1,1	93,0	122,0	1,0	178	534	1068	152,0	225,0	295,0	23,2	21,4	11 000		HS7017E.2RSD.T.P4S.UL	0,990
	85	130	22	25	1,1	93,0	122,0	1,0	76	228	456	60,0	92,0	123,0	24,6	15,8	15 000		HC7017C.2RSD.T.P4S.UL	0,942
	85	130	22	36	1,1	93,0	122,0	1,0	123	369	738	152,0	224,0	289,0	23,2	15,0	13 000		HC7017E.2RSD.T.P4S.UL	0,942
	85	130	22	25	1,1	93,0	122,0	1,0	109	327	654	61,0	95,0	130,0	24,6	22,6	13 000	20 000	HS7017C.T.P4S.UL	0,990
	85	130	22	36	1,1	93,0	122,0	1,0	178	534	1068	152,0	225,0	295,0	23,2	21,4	11 000	18 000	HS7017E.T.P4S.UL	0,990
	85	130	22	25	1,1	93,0	122,0	1,0	76	228	456	60,0	92,0	123,0	24,6	15,8	15 000	24 000	HC7017C.T.P4S.UL	0,942
	85	130	22	36	1,1	93,0	122,0	1,0	123	369	738	152,0	224,0	289,0	23,2	15,0	13 000	20 000	HC7017E.T.P4S.UL	0,942
	85	130	22	25	1,1	93,0	122,0	1,0	76	228	456	60,0	92,0	123,0	39,3	15,8	19 000	32 000	XC7017C.T.P4S.UL	0,942
	85	130	22	36	1,1	93,0	122,0	1,0	123	369	738	152,0	224,0	289,0	37,1	15,0	16 000	26 000	XC7017E.T.P4S.UL	0,942
90	90	125	18	23	1,1	97,0	119,0	0,6	83	249	498	58,0	91,0	125,0	18,6	18,7	13 000		HS71918C.2RSD.T.P4S.UL	0,630
	90	125	18	34	1,1	97,0	119,0	0,6	133	399	798	146,0	215,0	280,0	17,7	17,7	11 000		HS71918E.2RSD.T.P4S.UL	0,630
	90	125	18	23	1,1	97,0	119,0	0,6	57	171	342	56,0	87,0	117,0	18,6	13,1	15 000		HC71918C.2RSD.T.P4S.UL	0,598
	90	125	18	34	1,1	97,0	119,0	0,6	92	276	552	145,0	215,0	277,0	17,7	12,4	13 000		HC71918E.2RSD.T.P4S.UL	0,598
	90	125	18	23	1,1	97,0	119,0	0,6	83	249	498	58,0	91,0	125,0	18,6	18,7	13 000	20 000	HS71918C.T.P4S.UL	0,630
	90	125	18	34	1,1	97,0	119,0	0,6	133	399	798	146,0	215,0	280,0	17,7	17,7	11 000	18 000	HS71918E.T.P4S.UL	0,630
	90	125	18	23	1,1	97,0	119,0	0,6	57	171	342	56,0	87,0	117,0	18,6	13,1	15 000	24 000	HC71918C.T.P4S.UL	0,598
	90	125	18	34	1,1	97,0	119,0	0,6	92	276	552	145,0	215,0	277,0	17,7	12,4	13 000	20 000	HC71918E.T.P4S.UL	0,598
	90	125	18	23	1,1	97,0	119,0	0,6	57	171	342	56,0	87,0	117,0	29,7	13,1	19 000	32 000	XC71918C.T.P4S.UL	0,598
	90	125	18	34	1,1	97,0	119,0	0,6	92	276	552	145,0	215,0	277,0	28,3	12,4	16 000	26 000	XC71918E.T.P4S.UL	0,598
	90	140	24	27	1,5	100,0	131,0	1,5	130	390	780	66,0	104,0	142,0	28,7	26,6	12 000		HS7018C.2RSD.T.P4S.UL	1,31
	90	140	24	39	1,5	100,0	131,0	1,5	207	621	1242	165,0	245,0	318,0	27,1	25,1	10 000		HS7018E.2RSD.T.P4S.UL	1,31
	90	140	24	27	1,5	100,0	131,0	1,5	89	267	534	64,0	99,5	133,5	28,7	18,6	14 000		HC7018C.2RSD.T.P4S.UL	1,25
	90	140	24	39	1,5	100,0	131,0	1,5	146	438	876	165,0	245,0	315,0	27,1	17,6	12 000		HC7018E.2RSD.T.P4S.UL	1,25

12. Measurement tables

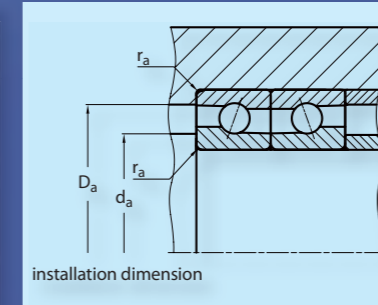
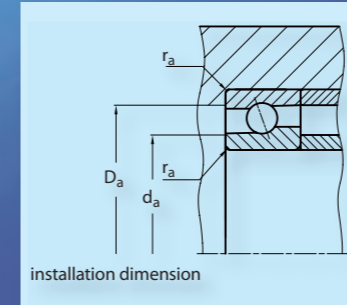
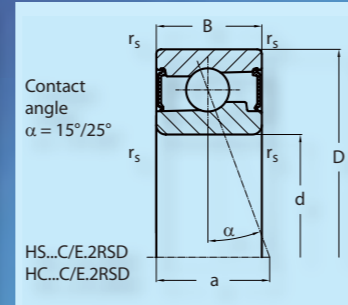
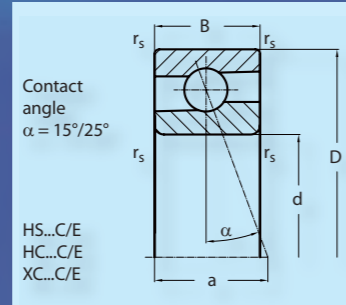

12. Measurement tables

Shaft	dimension (mm)					installation dimension (mm)			preload (N)			axial rigidity (N/μm)			load rating (kN)		speed limit (min ⁻¹)		Code	weight
	d	D	B	a	r _s min	d _a H12	D _a H12	r _a max	L	M	S	L	M	S	dyn C	stat Co	grease	oil	bearing	kg
90	90	140	24	27	1,5	100,0	131,0	1,5	130	390	780	66,0	104,0	142,0	28,7	26,6	12 000	19 000	HS7018C.T.P4S.UL	1,31
	90	140	24	39	1,5	100,0	131,0	1,5	207	621	1242	165,0	245,0	318,0	27,1	25,1	10 000	17 000	HS7018E.T.P4S.UL	1,31
	90	140	24	27	1,5	100,0	131,0	1,5	89	267	534	64,0	99,5	133,5	28,7	18,6	14 000	22 000	HC7018C.T.P4S.UL	1,25
	90	140	24	39	1,5	100,0	131,0	1,5	146	438	876	165,0	245,0	315,0	27,1	17,6	12 000	19 000	HC7018E.T.P4S.UL	1,25
	90	140	24	27	1,5	100,0	131,0	1,5	89	267	534	64,0	99,5	133,5	45,9	18,6	18 000	30 000	XC7018C.T.P4S.UL	1,25
	90	140	24	39	1,5	100,0	131,0	1,5	146	438	876	165,0	245,0	315,0	43,3	17,6	15 000	24 000	XC7018E.T.P4S.UL	1,25
95	95	130	18	24	1,1	102,0	124,0	0,6	85	255	509	60,8	94,8	129,4	19,1	19,8	12 000		HS71919C.2RSD.T.P4S.UL	0,660
	95	130	18	35	1,1	102,0	124,0	0,6	138	414	828	152,8	226,9	295,0	18,0	18,7	10 000		HS71919E.2RSD.T.P4S.UL	0,660
	95	130	18	24	1,1	102,0	124,0	0,6	59	177	354	59,7	91,4	122,5	19,1	13,9	14 000		HC71919C.2RSD.T.P4S.UL	0,626
	95	130	18	35	1,1	102,0	124,0	0,6	96	288	575	153,1	225,5	290,4	18,0	13,1	12 000		HC71919E.2RSD.T.P4S.UL	0,626
	95	130	18	24	1,1	102,0	124,0	0,6	85	255	509	60,8	94,8	129,4	19,1	19,8	12 000	19 000	HS71919C.T.P4S.UL	0,660
	95	130	18	35	1,1	102,0	124,0	0,6	138	414	828	152,8	226,9	295,0	18,0	18,7	10 000	17 000	HS71919E.T.P4S.UL	0,660
	95	130	18	24	1,1	102,0	124,0	0,6	59	177	354	59,7	91,4	122,5	19,1	13,9	14 000	22 000	HC71919C.T.P4S.UL	0,626
	95	130	18	35	1,1	102,0	124,0	0,6	96	288	575	153,1	225,5	290,4	18,0	13,1	12 000	19 000	HC71919E.T.P4S.UL	0,626
	95	130	18	24	1,1	102,0	124,0	0,6	59	177	354	59,7	91,4	122,5	30,5	13,9	18 000	30 000	XC71919C.T.P4S.UL	0,626
	95	130	18	35	1,1	102,0	124,0	0,6	96	288	575	153,1	225,5	290,4	28,7	13,1	16 000	26 000	XC71919E.T.P4S.UL	0,626
	95	145	24	28	1,5	105,0	136,0	1,5	130	390	780	67,5	105,0	144,0	29,1	27,6	11 000		HS7019C.2RSD.T.P4S.UL	1,34
	95	145	24	40	1,5	105,0	136,0	1,5	211	633	1266	170,0	252,0	328,0	27,4	26,1	9 500		HS7019E.2RSD.T.P4S.UL	1,34
	95	145	24	28	1,5	105,0	136,0	1,5	89	267	534	65,0	101,0	135,0	29,1	19,3	13 000		HC7019C.2RSD.T.P4S.UL	1,28
	95	145	24	40	1,5	105,0	136,0	1,5	146	438	876	169,0	249,0	321,0	27,4	18,3	11 000		HC7019E.2RSD.T.P4S.UL	1,28
	95	145	24	28	1,5	105,0	136,0	1,5	130	390	780	67,5	105,0	144,0	29,1	27,6	11 000	18 000	HS7019C.T.P4S.UL	1,34
	95	145	24	40	1,5	105,0	136,0	1,5	211	633	1266	170,0	252,0	328,0	27,4	26,1	9 500	16 000	HS7019E.T.P4S.UL	1,34
	95	145	24	28	1,5	105,0	136,0	1,5	89	267	534	65,0	101,0	135,0	29,1	19,3	13 000	20 000	HC7019C.T.P4S.UL	1,28
	95	145	24	40	1,5	105,0	136,0	1,5	146	438	876	169,0	249,0	321,0	27,4	18,3	11 000	18 000	HC7019E.T.P4S.UL	1,28
95	145	24	28	1,5	105,0	136,0	1,5	89	267	534	65,0	101,0	135,0	46,5	19,3	17 000	28 000	XC7019C.T.P4S.UL	1,28	
95	145	24	40	1,5	105,0	136,0	1,5	146	438	876	169,0	249,0	321,0	43,9	18,3	14 000	22 000	XC7019E.T.P4S.UL	1,28	
100	100	140	20	26	1,1	107,0	133,0	0,6	102	306	612	66,0	102,5	140,0	22,7	23,5	11 000		HS71920C.2RSD.T.P4S.UL	0,900
	100	140	20	38	1,1	107,0	133,0	0,6	166	498	996	166,0	245,0	320,0	21,4	22,1	9 500		HS71920E.2RSD.T.P4S.UL	0,900
	100	140	20	26	1,1	107,0	133,0	0,6	70	210	420	64,0	98,0	131,0	22,7	16,4	13 000		HC71920C.2RSD.T.P4S.UL	0,855
	100	140	20	38	1,1	107,0	133,0	0,6	115	345	690	164,0	243,0	314,0	21,4	15,5	11 000		HC71920E.2RSD.T.P4S.UL	0,855

12. Measurement tables

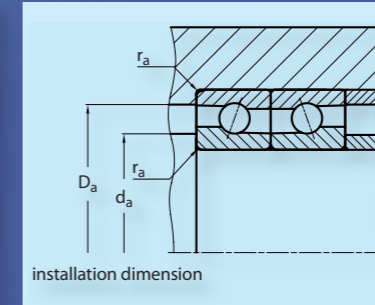
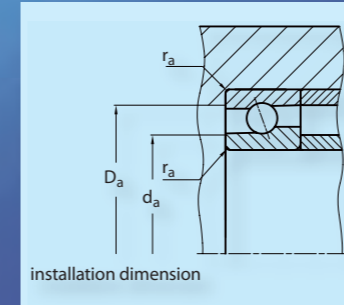
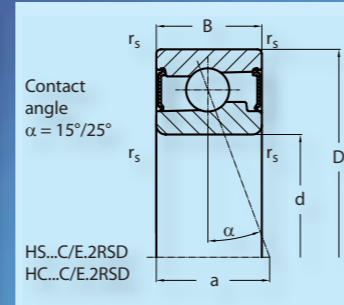
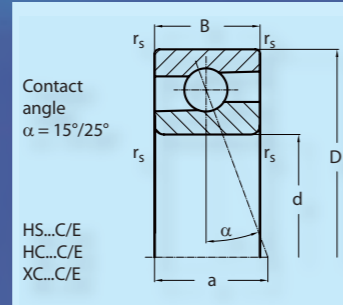

12. Measurement tables

Shaft	dimension (mm)					installation dimension (mm)			preload (N)			axial rigidity (N/μm)			load rating (kN)		speed limit (min ⁻¹)		Code	weight
	d	D	B	a	r _s min	d _a H12	D _a H12	r _a max	L	M	S	L	M	S	dyn C	stat Co	grease	oil	bearing	kg
100	100	140	20	26	1,1	107,0	133,0	0,6	102	306	612	66,0	102,5	140,0	22,7	23,5	11 000	18 000	HS71920C.T.P4S.UL	0,900
	100	140	20	38	1,1	107,0	133,0	0,6	166	498	996	166,0	245,0	320,0	21,4	22,1	9 500	16 000	HS71920E.T.P4S.UL	0,900
	100	140	20	26	1,1	107,0	133,0	0,6	70	210	420	64,0	98,0	131,0	22,7	16,4	13 000	20 000	HC71920C.T.P4S.UL	0,855
	100	140	20	38	1,1	107,0	133,0	0,6	115	345	690	164,0	243,0	314,0	21,4	15,5	11 000	18 000	HC71920E.T.P4S.UL	0,855
	100	140	20	26	1,1	107,0	133,0	0,6	70	210	420	64,0	98,0	131,0	36,3	16,4	17 000	28 000	XC71920C.T.P4S.UL	0,855
	100	140	20	38	1,1	107,0	133,0	0,6	115	345	690	164,0	243,0	314,0	34,2	15,5	14 000	22 000	XC71920E.T.P4S.UL	0,855
	100	150	24	29	1,5	110,0	141,0	1,5	134	402	804	70,0	109,0	149,5	29,4	28,6	11 000		HS7020C.2RSD.T.P4S.UL	1,40
	100	150	24	41	1,5	110,0	141,0	1,5	215	645	1290	174,0	259,0	335,0	27,8	27,0	9 000		HS7020E.2RSD.T.P4S.UL	1,40
	100	150	24	29	1,5	110,0	141,0	1,5	91	273	546	67,0	104,0	138,5	29,4	20,0	12 000		HC7020C.2RSD.T.P4S.UL	1,33
	100	150	24	41	1,5	110,0	141,0	1,5	148	444	888	173,0	255,0	330,0	27,8	18,9	11 000		HC7020E.2RSD.T.P4S.UL	1,33
	100	150	24	29	1,5	110,0	141,0	1,5	134	402	804	70,0	109,0	149,5	29,4	28,6	11 000	18 000	HS7020C.T.P4S.UL	1,40
	100	150	24	41	1,5	110,0	141,0	1,5	215	645	1290	174,0	259,0	335,0	27,8	27,0	9 000	15 000	HS7020E.T.P4S.UL	1,40
	100	150	24	29	1,5	110,0	141,0	1,5	91	273	546	67,0	104,0	138,5	29,4	20,0	12 000	19 000	HC7020C.T.P4S.UL	1,33
	100	150	24	41	1,5	110,0	141,0	1,5	148	444	888	173,0	255,0	330,0	27,8	18,9	11 000	18 000	HC7020E.T.P4S.UL	1,33
	100	150	24	29	1,5	110,0	141,0	1,5	91	273	546	67,0	104,0	138,5	47,1	20,0	16 000	26 000	XC7020C.T.P4S.UL	1,33
	100	150	24	41	1,5	110,0	141,0	1,5	148	444	888	173,0	255,0	330,0	44,4	18,9	14 000	22 000	XC7020E.T.P4S.UL	1,33
105	105	145	20	27	1,1	112,0	138,0	0,6	104	312	624	68,0	106,5	145,0	22,9	24,2	11 000	18 000	HS71921C.T.P4S.UL	0,900
	105	145	20	39	1,1	112,0	138,0	0,6	169	507	1014	172,0	255,0	332,0	21,5	22,8	9 000	15 000	HS71921E.T.P4S.UL	0,900
	105	145	20	27	1,1	112,0	138,0	0,6	71	213	426	67,0	102,0	137,0	22,9	16,9	12 000	19 000	HC71921C.T.P4S.UL	0,850
	105	145	20	39	1,1	112,0	138,0	0,6	117	351	702	171,0	253,0	327,0	21,5	16,0	11 000	18 000	HC71921E.T.P4S.UL	0,850
	105	145	20	27	1,1	112,0	138,0	0,6	71	213	426	67,0	102,0	137,0	36,6	16,9	16 000	26 000	XC71921C.T.P4S.UL	0,850
	105	145	20	39	1,1	112,0	138,0	0,6	117	351	702	171,0	253,0	327,0	34,5	16,0	14 000	22 000	XC71921E.T.P4S.UL	0,850
	105	160	26	31	2,0	116,0	150,0	2,0	170	510	1020	76,0	120,0	162,0	38,3	36,4	10 000	17 000	HS7021C.T.P4S.UL	1,80
	105	160	26	44	2,0	116,0	150,0	2,0	276	828	1656	190,0	285,0	369,0	36,1	34,4	8 500	14 000	HS7021E.T.P4S.UL	1,80
	105	160	26	31	2,0	116,0	150,0	2,0	118	354	708	74,0	114,0	152,0	38,3	25,4	12 000	19 000	HC7021C.T.P4S.UL	1,70
	105	160	26	44	2,0	116,0	150,0	2,0	192	576	1152	190,0	280,0	363,0	36,1	24,0	10 000	17 000	HC7021E.T.P4S.UL	1,70
	105	160	26	31	2,0	116,0	150,0	2,0	118	354	708	74,0	114,0	152,0	61,3	25,4	15 000	24 000	XC7021C.T.P4S.UL	1,70
	105	160	26	44	2,0	116,0	150,0	2,0	192	576	1152	190,0	280,0	363,0	57,8	24,0	13 000	21 000	XC7021E.T.P4S.UL	1,70
110	110	150	20	27	1,1	117,0	143,0	0,6	121	363	726	71,0	112,0	152,0	27,1	28,5	10 000	17 000	HS71922C.T.P4S.UL	1,00
	110	150	20	40	1,1	117,0	143,0	0,6	196	588	1175	180,0	268,0	349,0	25,6	26,8	8 500	14 000	HS71922E.T.P4S.UL	1,00
	110	150	20	27	1,1	117,0	143,0	0,6	83	249	498	70,0	107,0	144,0	27,1	19,9	12 000	19 000	HC71922C.T.P4S.UL	0,940
	110	150	20	40	1,1	117,0	143,0	0,6	135	405	810	180,0	265,0	340,0	25,6	18,8	10 000	17 000	HC71922E.T.P4S.UL	0,940
	110	150	20	27	1,1	117,0	143,0	0,6	83	249	498	70,0	107,0	144,0	43,4	19,9	15 000	24 000	XC71922C.T.P4S.UL	0,940
	110	150	20	40	1,1	117,0	143,0	0,6	135	405	810	180,0	265,0	340,0	40,9	18,8	13 000	20 000	XC71922E.T.P4S.UL	0,940

12. Measurement tables

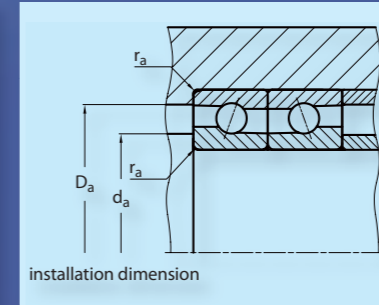
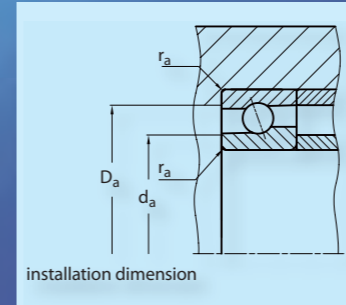
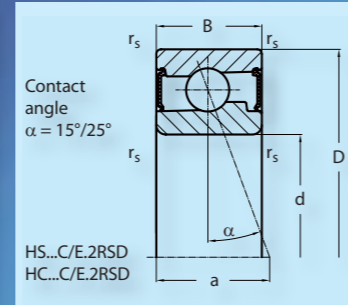
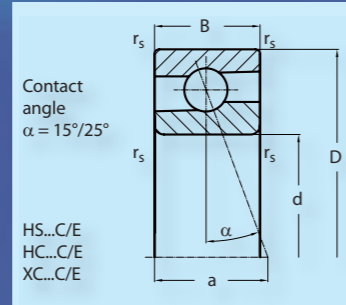

12. Measurement tables

Shaft	dimension (mm)					installation dimension (mm)			preload (N)			axial rigidity (N/μm)			load rating (kN)		speed limit (min ⁻¹)		Code	weight
	d	D	B	a	r _s min	d _a H12	D _a H12	r _a max	L	M	S	L	M	S	dyn C	stat Co	grease	oil	bearing	kg
110	110	170	28	33	2,0	121,0	159,0	2,0	174	522	1044	78,0	122,0	167,0	38,5	37,9	9 500	16 000	HS7022C.T.P4S.UL	2,20
	110	170	28	47	2,0	121,0	159,0	2,0	280	840	1680	196,0	292,0	378,5	36,4	35,8	8 000	13 000	HS7022E.T.P4S.UL	2,20
	110	170	28	33	2,0	121,0	159,0	2,0	118	354	708	76,0	117,0	157,0	38,5	26,5	11 000	18 000	HC7022C.T.P4S.UL	2,10
	110	170	28	47	2,0	121,0	159,0	2,0	192	576	1152	195,0	287,0	370,0	36,4	25,0	9 000	15 000	HC7022E.T.P4S.UL	2,10
	110	170	28	33	2,0	121,0	159,0	2,0	118	354	708	76,0	117,0	157,0	61,7	26,5	14 000	22 000	XC7022C.T.P4S.UL	2,10
	110	170	28	47	2,0	121,0	159,0	2,0	192	576	1152	195,0	287,0	370,0	58,2	25,0	12 000	19 000	XC7022E.T.P4S.UL	2,10
120	120	165	22	30	1,1	128,0	157,0	0,6	127	381	762	78,0	122,0	165,0	28,2	30,6	9 000	15 000	HS71924C.T.P4S.UL	1,30
	120	165	22	44	1,1	128,0	157,0	0,6	207	621	1242	196,0	291,0	379,0	26,8	28,8	8 000	13 000	HS71924E.T.P4S.UL	1,30
	120	165	22	30	1,1	128,0	157,0	0,6	88	264	528	76,0	116,0	155,0	28,2	21,4	11 000	18 000	HC71924C.T.P4S.UL	1,23
	120	165	22	44	1,1	128,0	157,0	0,6	143	429	858	195,0	288,0	371,0	26,6	20,2	9 000	15 000	HC71924E.T.P4S.UL	1,23
	120	165	22	30	1,1	128,0	157,0	0,6	88	264	528	76,0	116,0	155,0	45,2	21,4	14 000	22 000	XC71924C.T.P4S.UL	1,23
	120	165	22	44	1,1	128,0	157,0	0,6	143	429	858	195,0	288,0	371,0	42,6	20,2	12 000	19 000	XC71924E.T.P4S.UL	1,23
	120	180	28	34	2,0	131,0	169,0	2,0	179	537	1074	82,5	128,0	175,0	39,6	40,6	8 500	14 000	HS7024C.T.P4S.UL	2,30
	120	180	28	49	2,0	131,0	169,0	2,0	288	864	1728	207,0	305,0	398,0	37,3	38,3	7 500	12 000	HS7024E.T.P4S.UL	2,30
	120	180	28	34	2,0	131,0	169,0	2,0	123	369	738	81,0	123,0	165,0	39,6	28,4	10 000	17 000	HC7024C.T.P4S.UL	2,10
	120	180	28	49	2,0	131,0	169,0	2,0	199	597	1194	204,0	303,0	390,0	37,3	26,8	8 500	14 000	HC7024E.T.P4S.UL	2,10
	120	180	28	34	2,0	131,0	169,0	2,0	123	369	738	81,0	123,0	165,0	63,4	28,4	13 000	20 000	XC7024C.T.P4S.UL	2,10
	120	180	28	49	2,0	131,0	169,0	2,0	199	597	1194	204,0	303,0	390,0	59,7	26,8	11 000	18 000	XC7024E.T.P4S.UL	2,10
130	130	180	24	33	1,5	139,0	171,0	0,6	145	435	870	83,0	128,5	175,0	32,5	36,5	8 500	14 000	HS71926C.T.P4S.UL	1,80
	130	180	24	48	1,5	139,0	171,0	0,6	238	714	1428	208,0	309,0	400,0	30,7	34,4	7 000	11 000	HS71926E.T.P4S.UL	1,80
	130	180	24	33	1,5	139,0	171,0	0,6	100	300	600	82,0	124,0	164,0	32,5	25,6	9 500	16 000	HC71926C.T.P4S.UL	1,70
	130	180	24	48	1,5	139,0	171,0	0,6	163	489	978	207,0	305,0	392,0	30,7	24,1	8 000	13 000	HC71926E.T.P4S.UL	1,70
	130	180	24	33	1,5	139,0	171,0	0,6	100	300	600	82,0	124,0	164,0	52,1	25,6	12 000	19 000	XC71926C.T.P4S.UL	1,70
	130	180	24	48	1,5	139,0	171,0	0,6	163	489	978	207,0	305,0	392,0	49,0	24,1	11 000	18 000	XC71926E.T.P4S.UL	1,70
	130	200	33	39	2,0	142,0	189,0	2,0	228	684	1368	93,0	145,0	198,0	50,9	53,2	7 500	12 000	HS7026C.T.P4S.UL	3,70
	130	200	33	55	2,0	142,0	189,0	2,0	368	1104	2208	234,0	347,0	450,0	48,0	50,2	6 700	10 000	HS7026E.T.P4S.UL	3,70
	130	200	33	39	2,0	142,0	189,0	2,0	159	477	954	91,0	140,0	187,0	50,9	37,2	9 000	15 000	HC7026C.T.P4S.UL	3,50
	130	200	33	55	2,0	142,0	189,0	2,0	257	771	1542	232,0	345,0	444,0	48,0	35,2	7 500	12 000	HC7026E.T.P4S.UL	3,50
	130	200	33	39	2,0	142,0	189,0	2,0	159	477	954	91,0	140,0	187,0	81,4	37,2	12 000	19 000	XC7026C.T.P4S.UL	3,50
	130	200	33	55	2,0	142,0	189,0	2,0	257	771	1542	232,0	345,0	444,0	76,8	35,2	10 000	17 000	XC7026E.T.P4S.UL	3,50

13.1. General

High-precision cylindrical roller bearings are manufactured in single and double-row design and represent ideal floating bearings. They are distinguished by a high radial stiffness. Besides use as floating bearing, they are also used where radially stiff, stable and high-precision bearings are required. The standard version of the bearings has a tapered bore for precise adjustment of radial play (taper 1:12). The desired radial clearance or radial pretensioning is thus adjusted by an axial shifting on the tapered shaft seat.

There are moreover cylindrical roller bearings with cylindrical bore. The order designation does not include the „K“ (e.g. NN3012M.HP).

The main dimensions correspond with the general rolling bearing dimensional plans as per DIN 616 (ISO 15).

13.2. Heat treatment

The high-precision cylindrical roller bearings are heat-treated such that they can be used with operating temperatures of up to 150°C. Bearings with an outer diameter greater than 120mm are dimensionally stable up to 200°C.

13.3. Designs

Single-row high-precision cylindrical roller bearings are produced in series N19 and N10. In case of design N, the inner ring has two ribs and the outer ring is without a rib.



Fig. 13.1. single-row high-precision cylindrical roller bearing

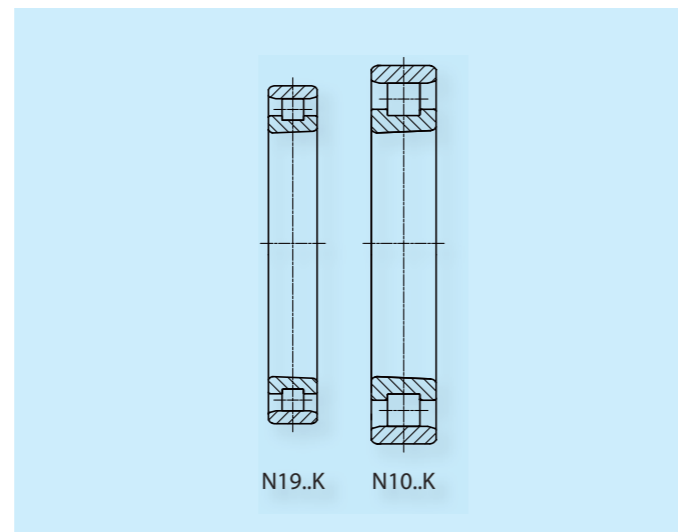

Fig. 13.2. series of single-row high-precision cylindrical roller bearing

Double-row high-precision cylindrical roller bearings are produced in series NN30 and NNU49 in accordance with DIN 5412-4. The NN designation implies that the bearing is double-row, the inner ring has three ribs, while the outer ring has not ribs. In case of design NNU, the outer ring has three ribs, while the inner ring is without a rib.

Upon request, the outer ring can be delivered with a lubrication groove and at least three lubrication holes. In this regard, an „S“ is indicated in the order designation after the code (e.g. NN3012K.S.M.HP). As a result, the lubricant can be supplied directly between the rollers.



Fig. 13.3. double-row high-precision cylindrical roller bearing, series NN30

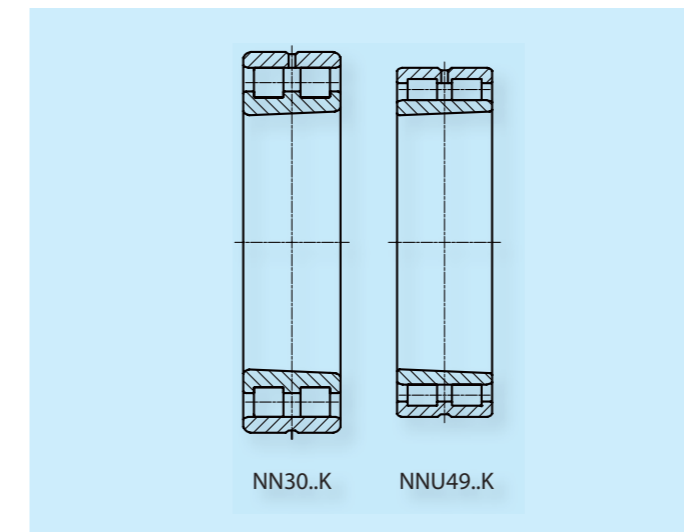

Fig. 13.5. series of double-row high-precision cylindrical roller bearing



Fig. 13.4. double-row high-precision cylindrical roller bearing, series NNU49

13.4. Hybrid cylindrical roller bearings

The hybrid cylindrical roller bearings of the HCN10 series have ceramic cylindrical rollers. Their use significantly improves characteristics in terms of friction and wear and tear. This results in decreased lubricant stress and lower temperatures. For this reason, higher speeds are also permissible.



Fig. 13.9. Hybrid cylindrical roller bearing

13.5. Materials

In the standard design, the bearing rings and cylindrical rollers of the high-precision cylindrical roller bearings are made of vacuum degassed chromium steel 100Cr6 or 100CrMnSi6-4 in case of larger dimensions.

The high-precision cylindrical roller bearings usually have a solid brass cage guided by rolling elements. Upon request, PEEK cages can also be used for single-row high-precision cylindrical roller bearings.



Fig. 13.7. PEEK cage, single-row



Fig. 13.6. brass cage, single-row



Fig. 13.8. brass cage, double-row

Tolerance class HP

The cylindrical roller bearings have a high precision due to their use and thus exhibit a tolerance class HP. It satisfies the tolerance class SP according to DIN 5412-4. Bearings with UP tolerance class can be manufactured for

applications with even greater demands according to DIN 5412-4. Upon request, the bearings are also available in other tolerance classes.

Inner ring (Dimensions in mm)											
Nominal bore diameter	over to	18 30	30 50	50 80	80 120	120 150	180 250	250 315	315 400	400 500	500 630
Tolerance class HP (Tolerances in μm)											
Cylindrical bore deviation	$\Delta_{\text{dmp}}, \Delta_{\text{ds}}$	0 -6	0 -8	0 -9	0 -10	0 -13	0 -15	0 -18	0 -23	0 -27	0 -30
Roundness	$V_{\text{dp}/2}$	1,5	2	2,5	2,5	3,5	4	4,5	6	7	8
Tapered bore deviation	Δ_{ds}	10 0	12 0	15 0	20 0	25 0	30 0	35 0	40 0	45 0	50 0
Roundness	$V_{\text{dp}/2}$	1,5	2	2,5	2,5	3,5	4	4,5	6	7	8
Deviation	$\Delta_{\text{d1mp}} - \Delta_{\text{dmp}}$	4 0	6 0	6 0	8 0	8 0	10 0	12 0	12 0	14 0	16 0
Width deviation	Δ_{Bs}	0 -120	0 -120	0 -150	0 -200	0 -250	0 -300	0 -350	0 -400	0 -450	0 -500
Width variation	V_{Bs}	5	5	6	7	8	10	13	15	17	20
Radial runout	K_{ia}	3	4	4	5	6	8	8	10	10	12
Variation in inclination of outside cylindrical surface to bore	S_{d}	8	8	8	9	10	11	13	15	17	20
Assembled bearing inner ring face runout with raceway (axial runout)	S_{ia}	8	8	8	9	10	13	15	20	23	25

Outer ring (Dimensions in mm)												
Nominal outside diameter	over to	30 50	50 80	80 120	120 150	150 180	180 250	250 315	315 400	400 500	500 630	630 800
Tolerance class HP (Tolerances in μm)												
Deviation	$\Delta_{\text{Dmp}}, \Delta_{\text{Ds}}$	0 -7	0 -9	0 -10	0 -11	0 -13	0 -15	0 -18	0 -20	0 -23	0 -28	0 -35
Variation	$V_{\text{Dp}/2}$	2	2,5	2,5	3	3,5	4	4,5	5	6	7	9
Radial runout	K_{ea}	5	5	6	7	8	10	11	13	15	17	20
Variation in inclination of outside cylindrical surface to outer ring side face	S_{D}	8	8	9	10	10	11	13	13	15	18	20
Assembled bearing outer ring face runout with raceway (axial runout)	S_{ea}	8	10	11	13	14	15	18	20	23	25	30

The width tolerances Δ_{CS} and V_{CS} are identical to Δ_{BS} and V_{BS} for the associated inner ring.

Tolerance class UP

Inner ring (Dimensions in mm)											
Nominal bore diameter	over to	18 30	30 50	50 80	80 120	120 150	180 250	250 315	315 400	400 500	500 630
Tolerance class UP (Tolerances in μm)											
Cylindrical bore deviation	$\Delta_{\text{dmp}}, \Delta_{\text{ds}}$	0 -5	0 -6	0 -7	0 -8	0 -10	0 -12	0 -15	0 -19	0 -23	0 -26
Roundness	$V_{\text{dp}/2}$	1,5	1,5	2	2	2,5	3	4	5	6	7
Tapered bore deviation	Δ_{ds}	6 0	7 0	8 0	10 0	12 0	14 0	15 0	17 0	19 0	20 0
Roundness	$V_{\text{dp}/2}$	1,5	1,5	2	2	2,5	3	4	5	6	7
Deviation	$\Delta_{\text{d1mp}} - \Delta_{\text{dmp}}$	2	3	3	4	4	5	6	6	7	8
Width deviation	Δ_{Bs}	-25	-30	-40	-50	-60	-75	-100	-100	-100	-125
Width variation	V_{Bs}	1,5	2	3	3	4	5	5	6	7	8
Radial runout	K_{ia}	1,5	2	2	3	3	4	4	5	5	6
Variation in inclination of outside cylindrical surface to bore	S_{d}	3	3	4	4	5	6	6	7	8	9
Assembled bearing inner ring face runout with raceway (axial runout)	S_{ia}	3	3	3	4	6	7	8	9	10	12

Outer ring (Dimensions in mm)												
Nominal outside diameter	over to	30 50	50 80	80 120	120 150	150 180	180 250	250 315	315 400	400 500	500 630	630 800
Tolerance class UP (Tolerances in μm)												
Deviation	$\Delta_{\text{Dmp}}, \Delta_{\text{Ds}}$	0 -5	0 -6	0 -7	0 -8	0 -9	0 -10	0 -12	0 -14	0 -17	0 -20	0 -25
Roundness	$V_{\text{Dp}/2}$	1,5	1,5	2	2	2,5	2,5	3	3,5	4,5	5	6,5
Radial runout	K_{ea}	3	3	3	4	4	5	6	7	8	9	11
Variation in inclination of outside cylindrical surface to outer ring side face	S_{D}	2	2	3	3	3	4	4	5	5	6	7
Assembled bearing outer ring face runout with raceway (axial runout)	S_{ea}	4	4	5	6	7	9	9	12	12	14	17

The width tolerances Δ_{CS} and V_{CS} are identical to Δ_{BS} and V_{BS} for the associated inner ring.

Radial clearance of single-row and double-row high-precision cylindrical roller bearings C1

The bearings have a standard radial clearance C1 (smaller than normal play CN). Based on this bearing clearance, the bearings are not interchangeable, i.e. the outer rings cannot be switched out between the individual bearings as is the

case, e.g., with single-row cylindrical roller bearings. Both C1 and NA (for not interchangeable) is not indicated. Other radial clearances are available upon request.

Dimensions in mm																									
Nominal bore diameter	over to	24	30	40	50	65	80	100	120	140	160	180	200	225	250	280	315	355	400	450	500	560	630	710	800
with cylindrical bore (Bearing clearance in μm)																									
clearance group C1	over to	5	5	5	5	5	10	10	10	10	10	10	15	15	15	20	20	20	25	25	25	25	30	30	35
with tapered bore (Bearing clearance in μm)																									
clearance group C1	over to	10	15	15	17	20	25	35	40	45	50	55	60	60	65	75	80	90	100	110	120	130	140	160	170

16.1. General

The design calculation for the basic load rating and service life of bearings is based on the standard DIN ISO 76 (Static Load Ratings) and DIN ISO 281 (Dynamic Load Ratings and Nominal Rating Life). These standards describe comprehensive design calculations. As a result, we will only focus on the fundamental design calculations below. These design calculations are used to provide an approximate assessment of a bearing.

More in-depth bearing evaluations are possible by calculating the Hertzian contact pressure between rolling elements and race while taking into account the actual lubrication conditions with the aid of specific calculation programs. Please contact our Design department in this regard.

16.2. Nominal rating life

The bearing's rating life is indicated by the number of revolutions or hours of running until the bearing shows the first signs of damage. The most frequent causes are wear and tear, seizing up, and overheating due to overloading (mechanical and thermal) as well as material fatigue. The most frequent cause for failure in high-speed applications is overheating followed by the bearing seizing up. According to DIN ISO 281 the nominal service life of cylindrical roller bearings is calculated as follows:

$L_{10} = \left(\frac{C_r}{P_r}\right)^{10/3}$	in millions revolutions
$L_{10h} = \frac{L_{10} \cdot 10^6}{60 \cdot n}$	in hours

L_{10}	Nominal rating life in millions of revolutions with 10% failure probability
L_{10h}	Nominal rating life in hours with 10% failure probability
C_r	Dynamic radial load rating in N
P_r	Dynamic equivalent radial loading in N
F_r	Radial load in N
n	Revolutions in min^{-1}

16.3. Equivalent dynamic loading

If the bearings are subject to radial and axial loading at the same time, such loads are combined into an equivalent load for calculating the service life. There is only one radial load for high-precision cylindrical roller bearings.

The equivalent dynamic loading of cylindrical roller bearings with contact angle = 0° is:

$P_r = F_r$	in N
-------------	------

17.1. Machining tolerances of the parts surrounding the bearings

The high capacity of cylindrical roller bearings is only guaranteed if the accuracy of the relevant adjacent parts are adapted according to the precision of bearings. This is necessary since the rings of the cylindrical roller bearings adapt to the shape of the shaft or the housing bore. This can result in defects in form and misalignment, which in turn lead to increased operating temperatures. The higher the required speeds and levels of precision are for the bearing, the more these faults become evident. The average roughness Ra of the bearing seats must be complied with in order to ensure that the corresponding fit only varies very slightly in case of installation (smoothing of surfaces).

17.2. Guidelines for machining of cylindrical shafts

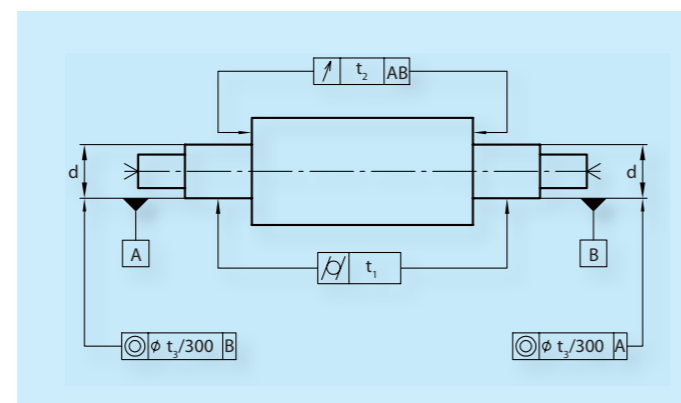

Fig. 17.1. Machining of cylindrical shafts

Installation tolerances of cylindrical shafts

		Nominal size of shaft d (in mm)											
		Tolerance class of bearing	over to	18 30	30 50	50 80	80 120	120 180	180 250	250 315	315 400	400 500	500 630
		Dimensions and tolerances (in μm)											
Dimension for d	HP (SP)			3 -3	3,5 -3,5	4 -4	5 -5	6 -6	7 -7	8 -8	9 -9	10 -10	11 -11
	UP			2 -2	2 -2	2,5 -2,5	3 -3	4 -4	5 -5	6 -6	6,5 -6,5	7,5 -7,5	8 -8
Cylindrical form t ₁	HP (SP)			1	1	1,2	1,5	2	3	4	5	6	7
	UP			0,6	0,6	0,8	1	1,2	2	2,5	3	4	5
Axial run-out t ₂	HP (SP)			1,5	1,5	2	2,5	3,5	4,5	6	7	8	9
	UP			1	1	1,2	1,5	2	3	4	5	6	7
Concentricity t ₃	HP (SP)			4	4	5	6	8	10	12	13	15	16
	UP			2,5	2,5	3	4	5	7	8	9	10	11
Average roughness Ra	HP (SP), UP			0,2	0,2	0,2	0,2	0,2	0,2	0,4	0,4	0,4	0,4

17.3. Guidelines for machining of tapered shafts

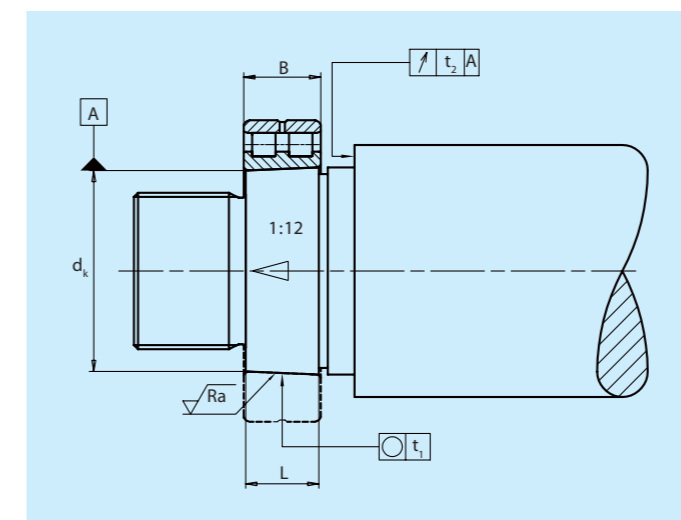

Fig. 17.2. Machining of tapered shafts

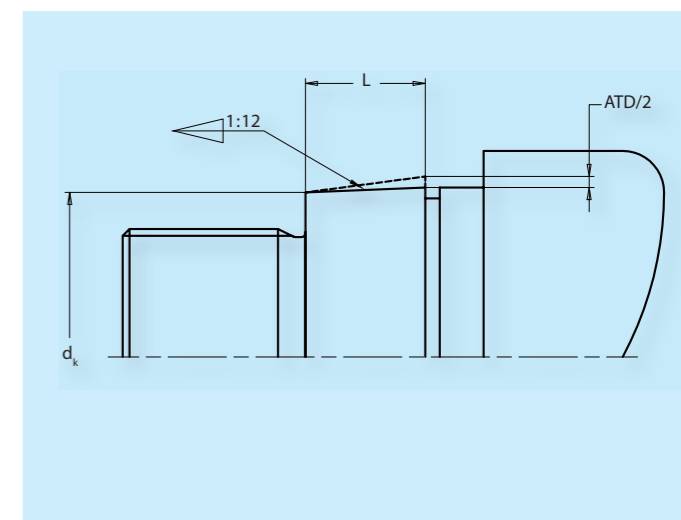

Fig. 17.3. Machining of tapered shafts (detail)

Installation tolerances of tapered shafts (1)

		Nominal size of shaft d (in mm)												
		Tolerance class of bearing	over to	18 30	30 40	40 50	50 65	65 80	80 100	100 120	120 140	140 160	160 180	180 200
		Dimensions and tolerances (in μm)												
Dimension for dk	HP(SP), UP			73 64	94 80	108 97	135 122	159 146	193 178	225 210	266 248	298 280	328 310	370 350
Roundness t ₁	HP(SP)			1	1	1	1,2	1,2	1,5	1,5	2	2	2	3
	UP			0,6	0,6	0,6	0,8	0,8	1	1	1,2	1,2	1,2	2
Axial run-out t ₂	HP(SP)			1,5	1,5	1,5	2	2	2,5	2,5	3,5	3,5	3,5	4,5
	UP			1	1	1	1,2	1,2	1,5	1,5	2	2	2	3
Average roughness Ra	HP(SP), UP			0,2	0,2	0,2	0,2	0,2	0,2	0,2	0,2	0,2	0,2	0,2

Installation tolerances of tapered shafts (2)

		Nominal size of shaft d (in mm)											
Tolerance class of bearing		over to	200 225	225 250	250 280	280 315	315 355	355 400	400 450	450 500	500 560	560 630	630 710
		Dimensions and tolerances (in μm)											
Dimension for d_k	HP(SP), UP		405 385	445 425	498 475	548 525	615 590	685 660	767 740	847 820	928 900	1008 980	1092 1060
Roundness t_1	HP(SP)		3	3	4	4	5	5	6	6	7	7	8
	UP		2	2	2,5	2,5	3	3	4	4	5	5	5
Axial run-out t_2	HP(SP)		4,5	4,5	6	6	7	7	8	8	9	9	10
	UP		3	3	4	4	5	5	6	6	7	7	8
Average roughness R_a	HP(SP), UP		0,2	0,2	0,4	0,4	0,4	0,4	0,4	0,4	0,4	0,4	0,4

Taper angle tolerance

		Taper length in L (in mm)					
Tolerance class of bearing		> 16...25	> 25...40	> 40...63	> 63...100	> 100...160	> 160...250
		Tolerances (in μm)					
Taper angle tolerance ATD	HP (SP)	+2...+3,2 0	+2,5...+4 0	+3,2...+5 0	+4...+6,3 0	+5...+8 0	+6,3...+10 0
	UP	+1,3...+2 0	+1,6...+2,5 0	+2...+3,2 0	+2,5...+4 0	+3,2...+5 0	+4...+6,3 0

17.4. Guidelines for machining of housing bores



Abb. 17.4. Machining of housing bores

		Nominal size of housing bore D (in mm)										
Tolerance class of bearing		over to	30 50	50 80	80 120	120 180	180 250	250 315	315 400	400 500	500 630	630 800
		Dimensions and tolerances (in μm)										
Dimension for d	HP (SP)		2 -9	3 -10	2 -13	3 -15	2 -18	3 -20	3 -22	2 -25	0 -29	0 -32
	UP		1 -6	1 -7	1 -9	1 -11	0 -14	0 -16	0 -17	0 -20	0 -22	0 -24
Cylindrical form t_1	HP (SP)		1,5	2	2,5	3,5	4,5	6	7	8	9	10
	UP		1	1,2	1,5	2	3	4	5	6	7	8
Axial run-out t_2	HP (SP)		2,5	3	4	5	7	8	9	10	11	12
	UP		1,5	2	2,5	3,5	4,5	6	7	8	9	10
Concentricity t_3	HP (SP)		4	5	6	8	10	12	13	15	16	18
	UP		2,5	3	4	5	7	8	9	10	11	12
Average roughness R_a	HP (SP), UP		0,2	0,4	0,4	0,4	0,4	0,8	0,8	0,8	1,6	1,6

18.1. Preparation of installation

Super precision bearings fulfill the stringent requirements on cleanliness and precision. The bearings should be installed with the utmost care. Make sure that they are installed in a room that is as clean as possible and free of dust with regulated temperature. Prior to installing the bearings, the dimensional accuracy of the connecting parts must be checked. Only provide and use tools that are suited for installation. Only open the bearing packages right before the installation. Remove excessive anti-corrosion oil with the aid of a clean lint-free cloth. In case of multiple bearings, the inner rings cannot be interchanged.

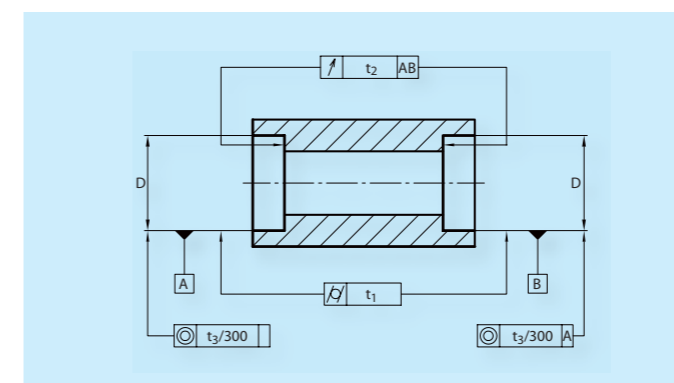
18.2. Greasing of bearings

In case of greasing and incompatibility of the anti-corrosion oil with the provided grease, the bearings are to be washed using a low-viscosity oil or kerosene and dry. Afterwards, apply the recommended amount of grease evenly to the outer and/or inner contour of the cage between the rollers, use your fingers to spread the grease on the rollers while manually turning them. *(The information on recommended amount of grease can be found in Section 23.2.3. Amount of grease).*

18.3. Bearing installation

The cylindrical roller bearings with tapered bore have a greater bearing clearance compared to those with a cylindrical bore. The tapered inner rings are secured to the shaft taper by means of clamping nuts. Depending on how much they are displaced axially, the inner ring expands and the bearing can be installed with play, without play or even with pretensioning.

Adjustment using envelop circle measuring device

To this end, the outer ring (series NN or N) is first installed in the housing and the race diameter is calculated. Subsequently, the outer envelop circle diameter of the cylindrical rollers are measured at the pretensioned inner ring with roller race. The difference between the race diameter and the envelop circle diameter results in the current bearing play and/or pretensioning. The desired parameters can be adjusted by further axial displacement.

The relevant dimension L must be calculated in order to be able to fix the bearing in this position with an adapter ring. For this purpose, the distance between the bearing's inner ring and shaft shoulder is measured at four measuring points staggered by 90°. After removing the inner ring, the smoothed adapter ring is slid onto the cylindrical part of the shaft between the shaft shoulder and inner ring. The inner ring is finally secured by means of a clamping nut.

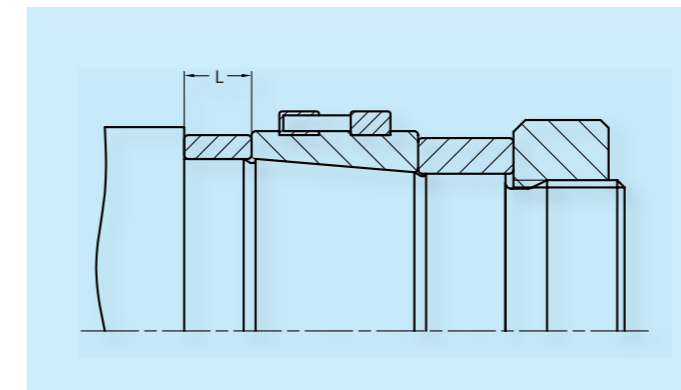

Fig. 18.1. Adjustment with envelop circle measuring device

Adjustment without envelop circle measuring device

Install the outer ring in the housing. Arbitrarily tension the inner ring with the roller race on the shaft taper and align it precisely in the housing. Measure the radial play by radially sliding the inner ring to the outer ring.

Allow for the desired radial play or pretensioning by axially shifting the inner ring. In case of taper 1:12, the sliding distance with solid shafts is approx. 20 times greater than the resulting radial expansion. Secure the bearing with an adapter ring in line with the adjustment using the envelop circle measuring device.

The set radial play or pretensioning influences the attainable speed as follows:

Single-row cylindrical roller bearings	
Radial play / pretensioning	Attainable speed
Pretensioning -5 bis 0 µm	<0,75 * n(grease)
0 µm, free of play	0,75 to 1 * n(grease)
Radial play 0 to 5 µm	1 to 1,1 * n(grease)
Radial play 0 to 5 µm	1 * n(oil)

Double-row cylindrical roller bearings	
Radial play / pretensioning	Attainable speed
Pretensioning -5 bis 0 µm	<0,5 * n(grease)
Radial play 0 to 2 * 10 ⁻⁵ * dm (mm)	0,5 bis 0,75 * n(grease)
Radial play 2 * 10 ⁻⁵ * dm to 4 * 10 ⁻⁵ * dm (mm)	0,75 bis 1 * n(grease)
Radial play 0 to 1 * 10 ⁻⁵ * dm (mm)	1 * n(oil)

Average bearing diameter $dm = (d+D)/2$

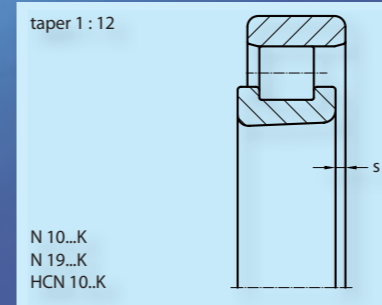
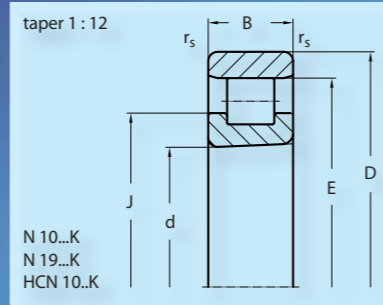

21.1. High-precision cylindrical roller bearings, single-row

Shaft	dimension (mm)							load rating (kn)		speed limit (min ⁻¹)		Code	weight
	d	D	B	r _s min	E	J	s	C dyn	Co stat	grease	oil	bearing	kg
30	30	55	13	0,6	48,5	38,7	1,9	20,7	21,0	19 000	22 000	N 1006K.M1.HP	0,130
	30	55	13	0,6	48,5	38,7	1,9	16,5	16,8	24 000	28 000	HCN 1006K.M1.HP	0,120
35	35	62	14	0,6	55,0	44,4	2,0	25,7	27,5	16 000	18 000	N 1007K.M1.HP	0,170
	35	62	14	0,6	55,0	44,4	2,0	20,6	22,0	22 000	25 000	HCN 1007K.M1.HP	0,150
40	40	68	15	0,6	61,0	49,7	2,1	29,9	32,7	15 000	17 000	N 1008K.M1.HP	0,210
	40	68	15	0,6	61,0	49,7	2,1	23,9	26,2	20 000	24 000	HCN 1008K.M1.HP	0,190
45	45	75	16	0,6	67,5	55,4	2,2	35,5	40,0	13 000	15 000	N 1009K.M1.HP	0,260
	45	75	16	0,6	67,5	55,4	2,2	28,4	32,0	17 000	19 000	HCN 1009K.M1.HP	0,230
50	50	72	12	0,6	66,5	57,9	1,8	22,4	27,5	13 000	15 000	N 1910K.M1.HP	0,150
	50	80	16	0,6	72,5	60,5	2,2	36,5	42,4	12 000	14 000	N 1010K.M1.HP	0,280
	50	80	16	0,6	72,5	60,5	2,2	29,2	33,9	16 000	18 000	HCN 1010K.M1.HP	0,250
55	55	80	13	1,0	73,5	64,1	1,9	25,0	31,5	12 000	14 000	N 1911K.M1.HP	0,210
	55	90	18	1,0	80,5	67,7	2,5	41,3	49,7	11 000	13 000	N 1011K.M1.HP	0,440
	55	90	18	1,0	80,5	67,7	2,5	33,0	39,8	14 000	16 000	HCN 1011K.M1.HP	0,400
60	60	85	13	1,0	78,5	69,1	1,9	26,0	34,0	11 000	13 000	N 1912K.M1.HP	0,220
	60	95	18	1,0	85,5	72,6	2,5	44,9	56,8	10 000	12 000	N 1012K.M1.HP	0,470
	60	95	18	1,0	85,5	72,6	2,5	35,9	45,5	13 000	15 000	HCN 1012K.M1.HP	0,410
65	65	90	13	1,0	83,5	74,1	1,9	29,0	40,0	10 000	12 000	N 1913K.M1.HP	0,240
	65	100	18	1,0	90,5	77,6	2,5	44,7	57,0	9 500	11 000	N 1013K.M1.HP	0,500
	65	100	18	1,0	90,5	77,6	2,5	36,0	46,0	12 000	14 000	HCN 1013K.M1.HP	0,450
70	70	100	16	1,0	92,5	81,0	2,3	36,5	49,0	9 500	11 000	N 1914K.M1.HP	0,380
	70	110	20	1,0	100,0	83,9	2,5	64,6	81,0	9 000	10 000	N 1014K.M1.HP	0,670
	70	110	20	1,0	100,0	83,9	2,5	51,6	64,8	12 000	14 000	HCN 1014K.M1.HP	0,590
75	75	105	16	1,0	97,0	86,0	2,3	38,0	53,0	9 000	10 000	N 1915K.M1.HP	0,410
	75	115	20	1,0	105,0	88,9	2,5	66,6	85,0	8 500	9 500	N 1015K.M1.HP	0,710
	75	115	20	1,0	105,0	88,9	2,5	53,3	68,0	11 000	13 000	HCN 1015K.M1.HP	0,630
80	80	110	16	1,0	102,5	91,0	2,3	39,0	56,0	8 500	9 500	N 1916K.M1.HP	0,430
	80	125	22	1,0	113,5	95,8	3,0	77,1	98,5	7 500	8 500	N 1016K.M1.HP	1,00
	80	125	22	1,0	113,5	95,8	3,0	61,7	78,8	10 000	12 000	HCN 1016K.M1.HP	0,880
85	85	120	18	1,0	110,5	97,9	2,5	52,1	74,8	7 500	8 500	N 1917K.M1.HP	0,600
	85	130	22	1,0	118,5	100,7	3,0	78,4	103,2	7 500	8 500	N 1017K.M1.HP	1,04
	85	130	22	1,0	118,5	100,7	3,0	62,7	82,6	10 000	12 000	HCN 1017K.M1.HP	0,920

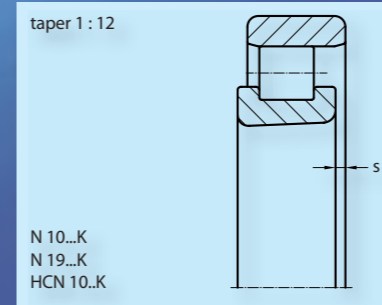
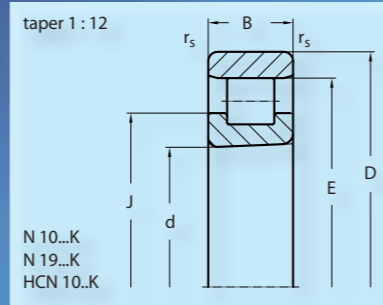

Shaft	dimension (mm)							load rating (kn)		speed limit (min ⁻¹)		Code	weight
	d	D	B	r _s min	E	J	s	C dyn	Co stat	grease	oil	bearing	kg
90	90	125	18	1,0	115,5	102,9	2,5	52,0	77,5	7 500	8 500	N 1918K.M1.HP	0,630
	90	140	24	1,1	127,0	107,6	3,2	93,0	124,0	6 700	7 500	N 1018K.M1.HP	1,39
	90	140	24	1,1	127,0	107,6	3,2	74,4	99,3	9 000	10 000	HCN 1018K.M1.HP	1,23
95	95	130	18	1,0	120,5	107,9	2,5	53,1	80,1	7 000	8 000	N 1919K.M1.HP	0,660
	95	145	24	1,1	132,0	112,6	3,2	95,8	129,7	6 300	7 000	N 1019K.M1.HP	1,34
	95	145	24	1,1	132,0	112,6	3,2	76,6	103,8	8 000	9 000	HCN 1019K.M1.HP	1,20
100	100	140	20	1,0	130,0	114,2	2,5	76,9	112,0	6 300	7 000	N 1920K.M1.HP	0,894
	100	150	24	1,1	137,0	117,6	3,2	97,8	134,0	6 000	6 700	N 1020K.M1.HP	1,39
	100	150	24	1,1	137,0	117,6	3,2	78,2	107,2	8 000	9 000	HCN 1020K.M1.HP	1,23
105	105	145	20	1,0	135,0	119,2	2,5	78,7	117,0	6 000	6 700	N 1921K.M1.HP	0,930
	105	160	26	1,1	145,5	124,5	3,4	113,6	156,9	5 600	6 300	N 1021K.M1.HP	1,82
	105	160	26	1,1	145,5	124,5	3,4	90,8	125,5	7 500	8 500	HCN 1021K.M1.HP	1,61
110	110	150	20	1,0	140,0	123,9	2,5	80,6	121,0	6 000	6 700	N 1922K.M1.HP	0,960
	110	170	28	1,1	155,0	130,8	3,4	140,6	189,5	5 300	6 000	N 1022K.M1.HP	2,23
	110	170	28	1,1	155,0	130,8	3,4	112,4	151,6	7 000	8 000	HCN 1022K.M1.HP	1,94
120	120	165	22	1,0	153,5	135,6	3,0	96,1	146,0	5 300	6 000	N 1924K.M1.HP	1,33
	120	180	28	1,1	165,0	140,8	3,4	148,0	208,5	5 000	5 600	N 1024K.M1.HP	2,45
	120	180	28	1,1	165,0	140,8	3,4	118,4	166,8	6 700	7 500	HCN 1024K.M1.HP	2,14
130	130	180	24	1,1	167,0	147,7	3,2	113,0	174,0	4 800	5 300	N 1926K.M1.HP	1,77
	130	200	33	1,1	182,0	154,6	4,2	181,0	257,0	4 300	4 800	N 1026K.M1.HP	3,62
140	140	190	24	1,1	177,0	158,0	3,2	117,6	190,0	4 300	4 800	N 1928K.M1.HP	1,89
	140	210	33	1,1	192,0	164,6	4,2	186,6	268,6	4 000	4 500	N 1028K.M1.HP	3,83
150	150	210	28	1,1	194,0	171,7	3,6	153,6	243,0	4 000	4 500	N 1930K.M1.HP	2,93
	150	225	35	1,5	205,5	176,5	4,4	213,4	313,2	3 800	4 300	N 1030K.M1.HP	4,71
160	160	220	28	1,1	204,0	181,7	3,6	156,4	259,0	3 800	4 300	N 1932K.M1.HP	3,13
	160	240	38	1,5	220,0	187,8	4,6	244,8	356,4	3 400	3 800	N 1032K.M1.HP	5,79
170	170	230	28	1,1	214,0	191,6	3,6	159,6	267,0	3 400	3 800	N 1934K.M1.HP	3,23
	170	260	42	2,1	237,0	200,9	5,0	297,8	441,0	3 200	3 600	N 1034K.M1.HP	7,70
180	180	250	33	1,1	232,0	204,8	4,2	215,2	348,0	3 200	3 600	N 1936K.M1.HP	4,82
	180	280	46	2,1	255,0	214,1	5,6	370,4	541,2	3 000	3 400	N 1036K.M1.HP	9,96
190	190	260	33	1,1	242,0	214,8	4,2	220,1	360,0	3 000	3 400	N 1938K.M1.HP	5,00
	190	290	46	2,1	265,0	224,1	5,6	376,5	566,6	2 800	3 200	N 1038K.M1.HP	10,4
200	200	280	38	1,5	259,0	228,5	4,8	268,9	443,0	2 800	3 200	N 1940K.M1.HP	6,00
	200	310	51	2,1	281,0	239,1	6,4	405,9	616,4	2 600	3 000	N 1040K.M1.HP	13,7

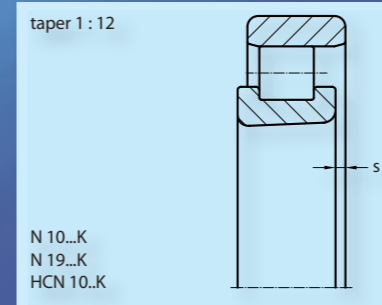
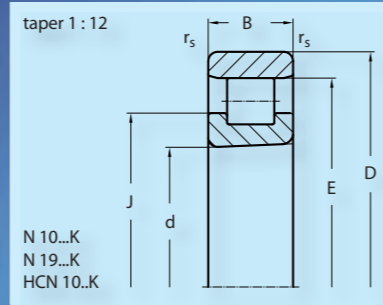

Shaft	dimension (mm)							load rating (kn)		speed limit (min ⁻¹)		Code	weight
	d	D	B	r _s min	E	J	s	C dyn	Co stat	grease	oil	bearing	kg
220	220	300	38	1,5	279,0	248,5	4,8	274,5	474,0	2 600	3 000	N 1944K.M1.HP	7,63
	220	340	56	3,0	310,0	261,7	6,6	516,2	775,0	2 400	2 800	N 1044K.M1.HP	17,9
240	240	320	38	1,5	299,0	268,5	4,8	292,5	519,0	2 400	2 800	N 1948K.M1.HP	8,22
	240	360	56	3,0	330,0	281,7	6,6	540,4	846,3	2 200	2 600	N 1048K.M1.HP	19,2
260	260	360	46	1,5	334,0	295,4	5,4	439,6	750,0	2 000	2 400	N 1952K.M1.HP	16,8
	260	400	65	4,0	364,0	309,3	8,1	669,0	1057,0	1 900	2 200	N 1052K.M1.HP	28,6
280	280	380	46	1,5	354,0	313,1	5,4	459,4	800,0	1 900	2 200	N 1956K.M1.HP	14,6
	280	420	65	4,0	384,0	329,3	8,1	708,8	1149,0	1 800	2 000	N 1056K.M1.HP	30,4
300	300	420	56	3,0	390,0	341,7	6,6	609,0	1061,0	1 700	1 900	N 1960K.M1.HP	23,1
	300	460	74	4,0	420,0	355,7	8,7	906,0	1437,0	1 600	1 800	N 1060K.M1.HP	43,0
320	320	440	56	3,0	410,0	361,7	6,6	637,0	1133,0	1 600	1 800	N 1964K.M1.HP	24,9
	320	480	74	4,0	440,0	375,7	8,7	920,0	1503,0	1 500	1 700	N 1064K.M1.HP	45,2
340	340	460	56	3,0	430,0	381,7	6,6	665,0	1204,0	1 500	1 700	N 1968K.M1.HP	26,3
	340	520	82	5,0	475,0	402,7	9,3	1100,0	1795,0	1 400	1 600	N 1068K.M1.HP	60,7
360	360	480	56	3,0	450,0	401,7	6,6	662,0	1243,0	1 400	1 600	N 1972K.M1.HP	27,5
	360	540	82	5,0	495,0	421,6	9,3	1132,0	1876,0	1 300	1 500	N 1072K.M1.HP	64,4
380	380	520	65	4,0	484,0	429,6	8,1	815,0	1500,0	1 300	1 500	N 1976K.M1.HP	40,0
	380	560	82	5,0	515,0	441,6	9,3	1165,0	1958,0	1 300	1 500	N 1076K.M1.HP	66,8
400	400	540	65	4,0	504,0	449,6	8,1	815,0	1580,0	1 300	1 500	N 1980K.M1.HP	41,7
	400	600	90	5,0	550,0	470,0	10,4	1435,0	2448,0	1 200	1 400	N 1080K.M1.HP	86,2
420	420	560	65	4,0	524,0	469,6	8,1	850,0	1630,0	1 200	1 400	N 1984K.M1.HP	43,5
	420	620	90	5,0	570,0	489,7	10,4	1400,0	2400,0	1 100	1 300	N 1084K.M1.HP	90,7
440	440	600	74	4,0	558,0	497,2	9,1	1020,0	1960,0	1 100	1 300	N 1988K.M1.HP	60,2
	440	650	94	6,0	597,0	513,5	10,8	1560,0	2750,0	1 100	1 300	N 1088K.M1.HP	106
460	460	620	74	4,0	578,0	517,2	9,1	1060,0	2080,0	1 100	1 300	N 1992K.M1.HP	62,6
	460	680	100	6,0	624,0	536,5	11,6	1660,0	3000,0	1 000	1 200	N 1092K.M1.HP	120
480	480	650	78	5,0	605,0	541,0	9,5	1140,0	2240,0	1 000	1 200	N 1996K.M1.HP	73,1
	480	700	100	6,0	644,0	556,4	11,6	1700,0	3100,0	0 950	1 100	N 1096K.M1.HP	125
500	500	670	78	5,0	625,0	561,0	9,5	1180,0	2360,0	1 000	1 200	N 19/500K.M1.HP	75,7
	500	720	100	6,0	664,0	576,5	11,6	1760,0	3200,0	950	1 100	N 10/500K.M1.HP	130

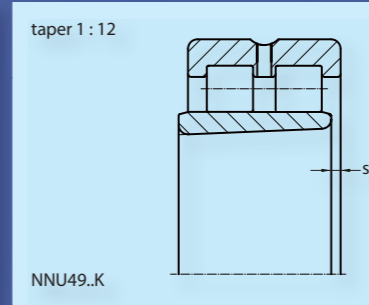
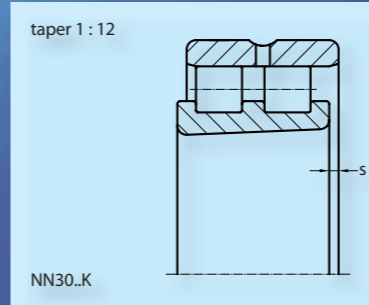
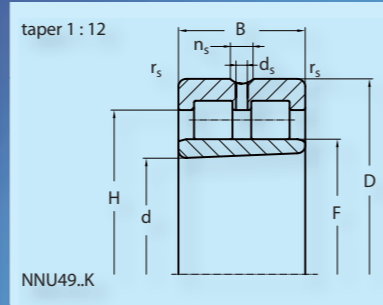
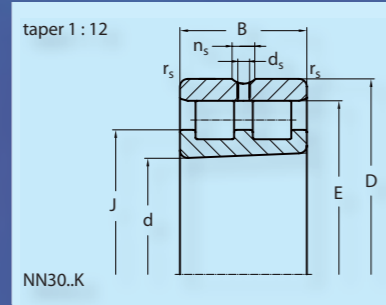

21.2. High-precision cylindrical roller bearings, double-row

Shaft	dimension (mm)											load rating (kn)		speed limit (min ⁻¹)		Code	weight
	d	D	B	r _s min	E	J	F	H	n _s	d _s	s	C dyn	Co stat	grease	oil	bearing	kg
30	30	55	19	1,0	48,5	39,7			4,8	3,2	1,4	29	34	16 000	19 000	NN3006K.M.HP	0,191
35	35	62	20	1,0	55,0	45,4			4,8	3,2	1,4	36	44	14 000	17 000	NN3007K.M.HP	0,249
40	40	68	21	1,0	61,0	50,6			4,8	3,2	1,4	42	53	12 000	15 000	NN3008K.M.HP	0,303
45	45	75	23	1,0	67,5	56,3			4,8	3,2	1,7	54	72	11 000	14 000	NN3009K.M.HP	0,393
50	50	80	23	1,0	72,5	61,3			4,8	3,2	1,7	57	79	10 000	13 000	NN3010K.M.HP	0,426
55	55	90	26	1,1	81,0	68,2			4,8	3,2	1,9	71	100	9 000	11 000	NN3011K.M.HP	0,630
60	60	95	26	1,1	86,1	73,3			4,8	3,2	1,9	74	109	8 500	10 000	NN3012K.M.HP	0,674
65	65	100	26	1,1	91,0	78,2			4,8	3,2	1,9	77	114	8 000	9 500	NN3013K.M.HP	0,715
70	70	110	30	1,1	100,0	85,6			6,5	3,2	2,3	98	148	7 000	8 500	NN3014K.M.HP	1,04
75	75	115	30	1,1	105,0	90,6			6,5	3,2	2,3	99	155	6 700	8 000	NN3015K.M.HP	1,07
80	80	125	34	1,1	113,0	97,0			6,5	3,2	2,5	120	186	6 300	7 500	NN3016K.M.HP	1,50
85	85	130	34	1,1	118,0	102,0			6,5	3,2	2,5	125	201	6 000	7 000	NN3017K.M.HP	1,56
90	90	140	37	1,5	127,0	109,4			6,5	3,2	2,6	140	225	5 600	6 700	NN3018K.M.HP	2,05
95	95	145	37	1,5	132,0	114,4			6,5	3,2	2,6	144	234	5 300	6 300	NN3019K.M.HP	2,13
100	100	140	40	1,1			113,0	125,8	6,5	3,2	2,0	129	253	5 300	6 300	NNU4920K.M.HP	1,85
	100	150	37	1,5	137,0	119,4			6,5	3,2	2,6	148	243	5 300	6 300	NN3020K.M.HP	2,28
105	105	145	40	1,1			118,0	130,8	6,5	3,2	2,0	128	261	5 300	6 300	NNU4921K.M.HP	1,92
	105	160	41	2,0	146,0	125,2			6,5	3,2	2,6	195	314	4 800	5 600	NN3021K.M.HP	2,84
110	110	150	40	1,1			123,0	135,8	6,5	3,2	2,0	131	269	5 000	6 000	NNU4922K.M.HP	2,07
	110	170	45	2,0	155,0	132,6			6,5	3,2	2,9	222	361	4 500	5 300	NN3022K.M.HP	3,61
120	120	165	45	1,1			134,5	150,5	6,5	3,2	2,3	175	341	4 500	5 300	NNU4924K.M.HP	2,75
	120	180	46	2,0	165,0	142,6			6,5	3,2	3,1	242	416	4 300	5 000	NN3024K.M.HP	3,92
130	130	180	50	1,5			146,0	162,0	6,5	3,2	2,7	186	385	4 000	4 800	NNU4926K.M.HP	3,80
	130	200	52	2,0	182,0	156,4			9,5	4,8	3,1	296	498	3 800	4 500	NN3026K.M.HP	5,80
140	140	190	50	1,5			156,0	172,0	6,5	3,2	2,7	190	398	3 800	4 500	NNU4928K.M.HP	4,05
	140	210	53	2,0	192,0	166,4			9,5	4,8	3,4	299	520	3 600	4 300	NN3028K.M.HP	6,15
150	150	210	60	2,0			168,5	191,0	6,5	3,2	2,7	331	652	3 600	4 300	NNU4930K.M.HP	6,00
	150	225	56	2,1	206,0	178,8			9,5	4,8	3,8	336	592	3 400	4 000	NN3030K.M.HP	7,53
160	160	220	60	2,0			178,5	201,0	6,5	3,2	2,7	331	676	3 400	4 000	NNU4932K.M.HP	6,40
	160	240	60	2,1	219,0	190,2			9,5	4,8	4,3	376	669	3 200	3 800	NN3032K.M.HP	9,10
170	170	230	60	2,0			188,5	211,0	6,5	3,2	2,7	339	700	3 200	3 800	NNU4934K.M.HP	6,68
	170	260	67	2,1	236,0	204,0			9,5	4,8	4,6	449	805	3 000	3 600	NN3034K.M.HP	12,5
180	180	250	69	2,0			202,0	222,0	9,5	4,8	3,2	404	856	3 000	3 600	NNU4936K.M.HP	9,89
	180	280	74	2,1	255,0	218,2			12,2	6,3	4,8	566	996	2 800	3 400	NN3036K.M.HP	16,4

21. Measurement tables

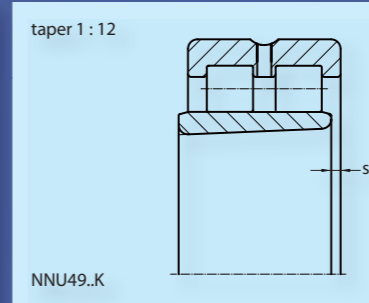
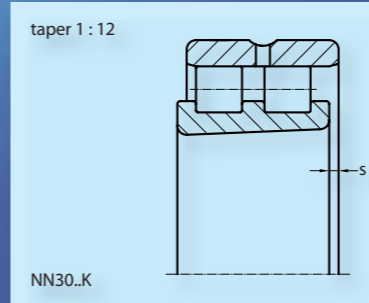
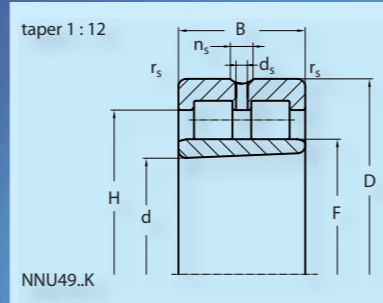
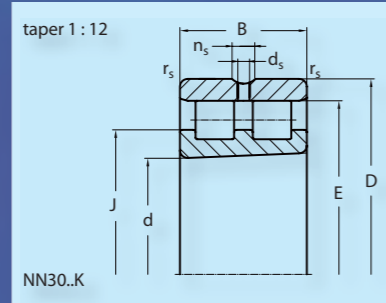

21. Measurement tables

Shaft	dimension (mm)											load rating (kn)		speed limit (min ⁻¹)		Code	weight
	d	D	B	r _s min	E	J	F	H	n _s	d _s	s	C dyn	Co stat	grease	oil	bearing	kg
190	190	260	69	2,0			212,0	236,0	9,5	4,8	3,2	413	885	2 800	3 400	NNU4938K.M.HP	10,2
	190	290	75	2,1	265,0	228,2			12,2	6,3	4,8	583	1039	2 600	3 200	NN3038K.M.HP	17,3
200	200	280	80	2,1			225,0	252,2	12,2	6,3	4,3	488	1040	2 600	3 200	NNU4940K.M.HP	14,5
	200	310	82	2,1	282,0	242,0			12,2	6,3	5,7	655	1190	2 400	3 000	NN3040K.M.HP	22,2
220	220	300	80	2,1			245,0	272,2	12,2	6,3	4,3	505	1139	2 400	3 000	NNU4944K.M.HP	15,7
	220	340	90	3,0	310,0	265,2			15,0	8,0	5,7	806	1454	2 200	2 800	NN3044K.M.HP	29,1
240	240	320	80	2,1			265,0	292,2	12,2	6,3	4,3	525	1206	2 200	2 800	NNU4948K.M.HP	16,8
	240	360	92	3,0	330,0	285,2			15,0	8,0	6,1	838	1577	2 000	2 600	NN3048K.M.HP	31,6
260	260	360	100	2,1			292,0	325,6	15,0	8,0	5,4	755	1690	2 000	2 600	NNU4952K.M.HP	29,3
	260	400	104	4,0	364,0	312,8			15,0	8,0	6,6	1073	2006	1 900	2 400	NN3052K.M.HP	46,2
280	280	380	100	2,1			312,0	345,6	15,0	8,0	5,4	764	1794	1 900	2 400	NNU4956K.M.HP	31,2
	280	420	106	4,0	384,0	332,8			15,0	8,0	6,9	1085	2093	1 800	2 200	NN3056K.M.HP	49,7
300	300	420	118	3,0			339,0	379,0	17,7	9,5	6,3	1040	2380	1 700	2 000	NNU4960K.M.HP	48,7
	300	460	118	4,0	418,0	360,4			17,7	9,5	7,5	1256	2402	1 600	1 900	NN3060K.M.HP	68,8
320	320	440	118	3,0			359,0	399,0	17,7	9,5	6,3	1084	2527	1 600	1 900	NNU4964K.M.HP	51,0
	320	480	121	4,0	438,0	380,4			17,7	9,5	8,0	1330	2600	1 600	1 900	NN3064K.M.HP	74,2
340	340	460	118	3,0			379,0	419,0	17,7	9,5	6,3	1095	2670	1 500	1 800	NNU4968K.M.HP	56,3
	340	520	133	5,0	473,0	409,0			17,7	9,5	8,8	1625	3220	1 400	1 700	NN3068K.M.HP	99,3
360	360	480	118	3,0			399,0	439,0	17,7	9,5	6,3	1137	2820	1 500	1 800	NNU4972K.M.HP	59,2
	360	540	134	5,0	493,0	429,0			17,7	9,5	8,8	1665	3350	1 400	1 700	NN3072K.M.HP	104
380	380	520	140	4,0			426,0	470,0	17,7	9,5	7,2	1434	3620	1 400	1 700	NNU4976K.M.HP	87,5
	380	560	135	5,0	513,0	449,0			17,7	9,5	9,1	1695	3480	1 300	1 600	NN3076K.M.HP	110
400	400	540	140	4,0			446,0	491,0	17,7	9,5	7,2	1490	3821	1 300	1 600	NNU4980K.M.HP	91,7
	400	600	148	5,0	549,0	477,0			17,7	9,5	9,5	2160	4500	1 200	1 500	NN3080K.M.HP	143
420	420	560	140	4,0			466,0	511,0	17,7	9,5	7,2	1546	4022	1 300	1 600	NNU4984K.M.HP	95,4
	420	620	150	5,0	569,0	497,0			17,7	9,5	10,0	2100	4520	1 200	1 500	NN3084K.M.HP	148
440	440	600	160	4,0			490,0	545,0	17,7	9,5	6,8	2010	5157	1 200	1 500	NNU4988K.M.HP	133
	440	650	157	6,0	597,0	520,0			23,5	12,5	10,2	2460	5120	1 100	1 400	NN3088K.M.HP	170
460	460	620	160	4,0			510,0	564,0	17,7	9,5	6,8	2092	5457	1 100	1 400	NNU4992K.M.HP	135
	460	680	163	6,0	624,0	544,0			23,5	12,5	10,9	2610	5395	1 100	1 400	NN3092K.M.HP	197
480	480	650	170	5,0			534,0	593,0	17,7	9,5	7,2	2326	6113	1 100	1 400	NNU4996K.M.HP	156
	480	700	165	6,0	644,0	564,0			23,5	12,5	11,2	2690	5860	1 000	1 300	NN3096K.M.HP	203
500	500	670	170	5,0			554,0	613,0	17,7	9,5	7,2	2258	5900	1 000	1 300	NNU49/500K.M.HP	161
	500	720	167	6,0	664,0	584,0			23,5	12,5	11,7	2600	5840	1 000	1 300	NN30/500K.M.HP	212

22.1. Bore diameter

d	Nominal diameter of bore
d_s	Individual bore diameter
d_{sp}	Individual bore diameter in single plane
Δ_{ds}	Deviation of individual bore diameter, difference between an individual bore diameter and the nominal diameter of the bore, $\Delta_{ds} = d_s - d$
V_{ds}	Variation in bore diameter, difference between the largest and smallest individual bore diameter of an individual ring, $V_{ds} = d_{smax} - d_{smin}$
d_m	Average bore diameter, arithmetic mean of the largest and smallest of the individual bore diameters of an individual ring, $d_m = (d_{smay} + d_{smin}) / 2$
Δ_{dm}	Deviation of average bore diameter, difference between the average bore diameter and the nominal diameter of the bore, $\Delta_{dm} = d_m - d$
d_{mp}	Average bore diameter in a single plane, arithmetic mean of the largest and smallest individual bore diameter determinable in a radial plane, $d_{mp} = (d_{spmax} + d_{spmin}) / 2$
Δ_{dmp}	Deviation of average bore diameter in a single plane, difference between the average bore diameter and the nominal diameter in a radial plane, $\Delta_{dmp} = d_{mp} - d$
V_{d_p}	Variation of individual bore diameter in a single plane, difference between the largest and smallest bore diameter determinable in a radial plane, $V_{d_p} = d_{pmax} - d_{pmin}$
V_{dmp}	Variation of medium bore diameter, difference between the largest and smallest medium bore diameter determinable in individual radial planes respectively at an individual ring, $V_{dmp} = d_{mpmax} - d_{mpmin}$
V_{d_p}/2}	Roundness of a level

22.2. Shell diameter

D	Nominal diameter of shell (outer diameter)
D_s	Individual shell diameter
D_{sp}	Individual shell diameter in a single plane
Δ_{Ds}	Deviation of individual shell diameter, difference between an individual shell diameter and the nominal diameter of the shell, $\Delta_{Ds} = D_s - D$
V_{Ds}	Variation of shell diameter, difference between the largest and smallest individual shell diameter of an individual ring, $V_{Ds} = D_{smax} - D_{smin}$
D_m	Average shell diameter, arithmetic mean of the largest and smallest individual shell diameter of an individual ring, $D_m = (D_{smax} + D_{smin}) / 2$
Δ_{Dm}	Deviation of average shell diameter, difference between the average shell diameter and the nominal diameter of the shell, $\Delta_{Dm} = D_m - D$
D_{mp}	Average shell diameter in a single plane, arithmetic mean of the largest and smallest individual shell diameter determinable in a radial plane, $D_{mp} = (D_{spmax} + D_{spmin}) / 2$
Δ_{Dmp}	Deviation of average shell diameter in a single plane, difference between the average shell diameter and the nominal diameter of the shell in an individual radial plane, $\Delta_{Dmp} = D_{mp} - D$
V_{D_p}	Variation of individual shell diameter in a single plane, difference between the largest and smallest individual shell diameter determinable in an individual radial plane, $V_{D_p} = D_{pmax} - D_{pmin}$
V_{Dmp}	Variation of average shell diameter, difference between the largest and smallest average shell diameter determinable in individual radial planes respectively at an individual ring, $V_{Dmp} = D_{mpmax} - D_{mpmin}$
V_{D_p}/2}	Roundness of a level

22.3. Width

B	Nominal width of inner ring
C	Nominal width of outer ring
B_s	Individual inner ring width
C_s	Individual outer ring width
Δ_{Bs}	Deviation of individual inner ring width, difference between an individual inner ring width and the nominal width of the inner ring, $\Delta_{Bs} = B_s - B$
Δ_{Cs}	Deviation of individual outer ring width, difference between an individual outer ring width and the nominal width of the outer ring, $\Delta_{Cs} = C_s - C$
V_{Bs}	Variation of inner ring width, difference between the largest and smallest actual individual ring width of an individual inner ring, $V_{Bs} = B_{smax} - B_{smin}$
V_{Cs}	Variation of outer ring width, difference between the largest and smallest actual individual ring width of an individual outer ring, $V_{Cs} = C_{smax} - C_{smin}$
B_m	Average inner ring width, arithmetic mean of the largest and smallest individual ring width determinable at an outer ring, $B_m = (B_{smax} + B_{smin}) / 2$
C_m	Average outer ring width, arithmetic mean of the largest and smallest individual ring width determinable at an outer ring, $C_m = (C_{smax} + C_{smin}) / 2$

22.4. Corner radius

	Nominal chamfer dimensions
r_s	Individual chamfer dimensions
r_{smin}	Smallest individual chamfer dimensions, smallest permissible and individual radial and axial chamfer dimensions of a ring
r_{smax}	Largest individual chamfer dimensions, largest permissible and individual radial and axial chamfer dimensions of a ring

22.5. Variation in wall thickness

K_i	Variation in wall thickness between inner ring/race and bore, difference between the largest and smallest radial distance between the bore surface and the race on the outside of the inner ring, in middle of race
K_e	Variation in wall thickness between outer ring/race and outer ring/shell, difference between the largest and smallest radial distance between the shell surface and the race on the inside of the outer ring, in middle of race

22.6. Running accuracy

22.6.1. Radial run-out

K_{ia}	Radial run-out of the inner ring at the assembled bearing, difference between the largest and smallest radial distance between the bore surface of the inner ring, with different angle position of the inner ring, and a fixed point relating to the outer ring
K_{ea}	Radial run-out of the outer ring at the assembled bearing, difference between the largest and smallest radial distance between the shell surface of the outer ring, with different angle position of the outer ring, and a fixed point relating to the inner ring

22.6.2. Axial run-out

S_{ia}	Axial run-out of the inner ring at the assembled bearing, difference between the largest and smallest axial distance between the reference side surface of the inner ring, with different angle positions of the inner ring, at a radial distance from the inner ring axis equal to half of the race diameter of the inner ring and at a fixed point relating to the outer ring
S_{ea}	Axial run-out of the outer ring at the assembled bearing, difference between the largest and smallest axial distance between the reference side surface of the outer ring, with different angle positions of the outer ring, at a radial distance from the outer ring axis equal to half of the race diameter of the outer ring and at a fixed point relating to the inner ring

22.6.3. Lateral run-out

S_d	Axial run-out of the inner ring lateral surface to the bore (lateral run-out)
S_D	Variation in slope of the shell line to the reference side surface (lateral run-out)

23.1. General

Both grease and oil may be used as lubricants. The lubricant is a load-bearing element that separates the rolling elements and sliding elements from one another.

That's why it is necessary to ensure that lubricant is applied at all points of contact. In case of continuous lubrication, it also assumes the role of cooling at the same time. The choice of lubrication approach depends on the different operating conditions, such as speeds, temperatures and loads.

23.1. Grease lubrication

Grease is normally used as lubricant if extremely high speeds are not to be expected, Advantages of grease include:

- Less complex design
- Less system complexity
- Possibly of lifetime lubrication
- Compact size for lubrication equipment and seals
- Environmentally friendly

Thanks to the constant advances and innovations made in lubricating greases, it has been possible to increase bearing speeds considerably. Greased and sealed bearings also offer the advantage of ensuring maximum cleanliness, since the interior of the bearing is protected against dirt.

23.2.1. Grease service life

A grease's effectiveness deteriorates during operation and thus has a corresponding impact of the bearing's operation. That's why the grease service life is regarded as a key factor for the fatigue life of bearings.

k_f	1 for N10 and N19
k_f	2 for NN30 and NNU49
k_f	0,75 for spindle bearings with contact angle 15°
k_f	0,9 for spindle bearings with contact angle 25°
n	Speed
d_m	medium bearing diameter $(D+d)/2$

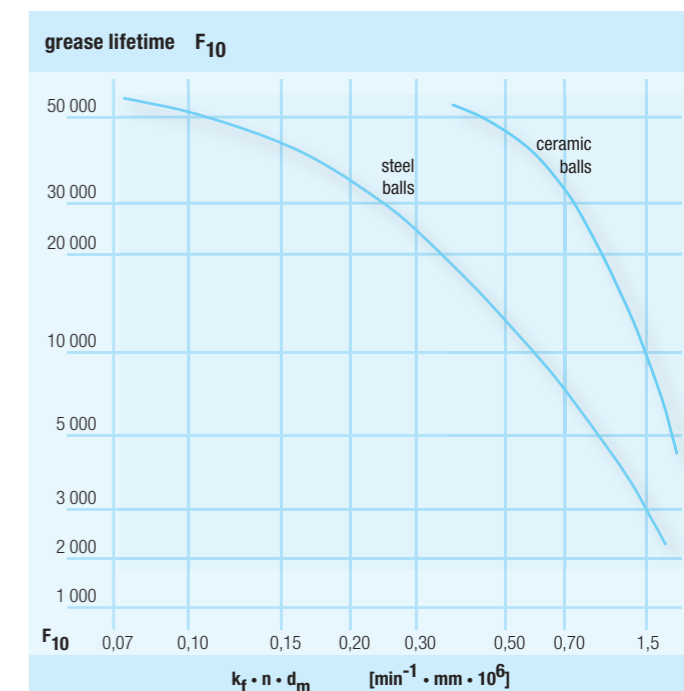

23.2.2. Running-in of grease

The performance of the bearings and thus their service life is influenced in a positive manner due to the careful commissioning of greased bearings. Running-in is recommended, which consists of running time and down time.

This ensures both a uniform distribution of the lubricating grease and prevents bearings from overheating during operation. For higher speeds, the running-in process should be implemented first at 50% and then at 0.75 times the expected rotational speed. The necessary number of running-in processes may vary depending on the size and number of bearings as well as maximum speed and bearing environment.

In general, we recommend the following start/stop cycle:

Speed	Run-time	Shutdown time	Repetition	Total time
0,5 * n_{max}	20 s	2 min	5x	11 min 40 s
0,75 * n_{max}	20 s	2 min	5x	11 min 40 s
n_{max}	20 s	2 min	5x	11 min 40 s
n_{max}	30 s	2 min	10x	25 min
n_{max}	1 min	1 min	10x	20 min

If the steady-state temperature is still not achieved, additional cycles are implemented with longer running periods and shorter downtimes.

23.2.3. Amount of grease

The amount of grease complies with the normal fill quantity N of the spindle bearing and refer to approx. 50% of the trouble-free interior of the bearing.

Spindle bearings					
bearing-series	HS719	HS70	B719	B70	B72
	HC719	HC70	HCB719	HCB70	HCB72
	XC719	XC70	XCB719	XCB70	XCB72
Bore number	Amount of grease in cm ³ per bearing				
02	0,25	0,43	0,16	0,31	0,47
03	0,29	0,55	0,16	0,42	0,63
04	0,41	0,92	0,31	0,7	1,2
05	0,5	0,87	0,36	0,8	1,4
06	0,64	1,38	0,39	1,16	2,2
07	0,94	2	0,74	1,52	2,9
08	1,56	2,5	1,12	2	3,7
09	1,71	3,6	1,31	2,8	4,4
10	1,77	4	1,45	2,7	4,2
11	2,4	5,5	1,88	3,6	6,3
12	2,5	5,3	2,3	4,1	7,8
13	2,7	6,4	2,4	4,2	8,9
14	4,4	8	4	7,1	9,6
15	5	9	4,4	7,5	12,5
16	4,3	9,8	4,1	10,2	11,9
17	7,6	12	6	9,9	17,8
18	7,7	14,9	6,1	11,5	18,5

Spindle bearings					
bearing-series	HS719	HS70	B719	B70	B72
	HC719	HC70	HCB719	HCB70	HCB72
	XC719	XC70	XCB719	XCB70	XCB72
Bore number	Amount of grease in cm ³ per bearing				
19	8,8	17,2	6,7	13,3	25,3
20	10,8	16,6	10,2	12,3	26,4
21	12	23,1	10,1	14,4	35,2
22	13,2	26,5	9,5	20,7	42,6
24	16,1	28,5	14,2	21,2	37,6
26	20,8	41,1	16,4	35,5	40,6
28	25,6	46,3	15,6	37,6	56,8
30	37,8	57,1	26,5	42,9	78,9
32	39,9	69,7	28,8	55,9	99,8
34			30,4	62,7	117
36			45,5	91,1	122
38			48	95,1	151
40			67,8	114	182
44			65,6	166	243
48			70,8	178	
52			113		
56			121		



Spindel- und Lagerungstechnik
Fraureuth GmbH

Fabrikgelände 5
08427 Fraureuth

Tel.: +49 (0) 37 61 / 80 10
Fax: +49 (0) 37 61 / 80 11 50

E-Mail: slf@slf-fraureuth.de
www.slf-fraureuth.de



**SPINDEL- UND LAGERUNGSTECHNIK
FRAUREUTH GMBH**

