



Rolling Element Bearings

unique design solutions
to complex problems



The Global Leader in Aerospace Bearings

Rolling Element Bearings

Aircraft Control Bearings

Ball Bearing Rod Ends

Needle and Lined Track Roller Bearings

Thin Section Ball Bearings

Custom Ball and Roller Bearing Applications

www.rbcbearings.com

INTRODUCTION

Industrial Heritage and Know-How	3
• Warranty	5
• Contact Information	6

AIRFRAME CONTROL AND ROD ENDS

• Engineering for Airframe Control and Ball Bearing Rod Ends	7–25
--	------

AIRFRAME CONTROL BALL BEARINGS

Airframe Control Bearings: Section Header – Index	26
• Product Nomenclature	27
Tables – Airframe Control Ball Bearings	
Single Row Ball Bearings	28–45
• Standard Series	28–38
• Precision Series	39–45
Double Row Ball Bearings	46–54
• Standard Series	46–51
• Precision Series	52–54

AIRFRAME CONTROL ROLLER BEARINGS

Airframe Control Roller Bearings: Section Header – Index	55
• Product Nomenclature	56
Tables – Airframe Control Roller Bearings	
• Single Row Self-aligning Convex Roller Bearings	57
• Double Row Self-aligning Concave Roller Bearings	58–59

BALL BEARING ROD ENDS

Ball Bearing Rod Ends: Section Header – Index	60
• Product Nomenclature	61
Tables – Ball Bearing Rod Ends	
• External Threaded Series	62
• AeroCres® Fracture-tough Airframe Products	63–64
• Internal Threaded Series	65
• Hollow & Solid Shank Series	66
Tables – Roller Rod Ends	
• RA/RR External Threaded Series	67
• RA/RR Internal Threaded Series	68

AIRFRAME CONTROL RADIAL BALL BEARINGS

Radial Ball Bearings: Section Header – Index	69
• Product Nomenclature	70
Tables – Radial Ball Bearings	
• Ultra-Light 9300K Series	71
• Extra-Light 9100K Series	72
• Engineering for Radial Ball Bearings	73–74

Continued on next page 

AIRFRAME CONTROL NEEDLE TRACK ROLLERS

Airframe Control Needle Roller Bearings: Section Header – Index	75
• Product Nomenclature	76
• Engineering for Needle Roller Bearings	77–82
Tables – Airframe Control Needle Roller Bearings	
• Single/Double Row Sealed Series	83–84
• AeroCres® Reduced Maintenance Products	85–86
• AeroCres® Reduced Maintenance Needle Track Roller Series	87–88
• Single/Double Row, Heavy Loads, Slow Speeds Series	89–90
• Single Row, Outer Supported by Housing Series	91–92
• Single/Double Row Self-aligning Series	93–94
• Single Row, Minimum Section Series	95–96
Tables – Airframe Control Stud-type Needle Roller Bearings	
• Stud-type Track Roller Series	97–98
• AeroCres® Fracture-tough Airframe Products	99–100
• AeroCres® Fracture-tough Stud-type Track Rollers	101–102
• Special Designs	103

AIRFRAME CONTROL LINED TRACK ROLLERS

Airframe Control Lined Roller Bearings: Section Header – Index	104
• Product Nomenclature	105
• Engineering for Lined Roller Bearings	106
Tables – Airframe Control Lined Track Rollers	
• Lined Track Rollers Series	107
• Lined Stud-type Track Roller Series	108

THIN SECTION BALL BEARINGS

Thin Section Ball Bearings: Section Header – Index	109
• Product Nomenclature	110–112
• Engineering for Thin Section Ball Bearings	113–121
• Thin Section Ball Bearings Tolerance and Fits	122–124
Tables – Thin Section Ball Bearings	
• Radial Contact, C-Type Series	126–131
• Angular Contact, A-Type Series	132–137
• 4-Point Contact, X-Type Series	138–143
• Sealed Radial Contact, C-Type Series	144–145
• Sealed 4-Point Contact, X-Type Series	146–147
• SuperDuplex™ Sealed Bearings Series	148–149
• Y-PWI Duplex Series	150
• THERMAL-COMP®	151

SAMPLE APPLICATIONS

• Thin Section Ball Bearings Custom Bearing Applications	152–165
• Helicopter Applications	166–167
• Airframe Applications	168–169

CONVERSION TABLES	170–171
--------------------------	----------------



RBC Aerospace Bearings – Plain Bearings Catalog

RBC Aerospace Bearings also offers a catalog dedicated to our precision Plain Bearing products including spherical bearings, rod end bearings, journal bearings, links and assemblies. This catalog features detailed information regarding general features and technical product specifications, part drawings, complete engineering sections for each product category, and ordering information.

Also available online.

Please visit us online at rbcbearings.com

RBC Aerospace Bearings Locations

**RBC AeroStructures
123 Commerce Way
Westminster, SC 29693
Phone: 864.886.4601**

**Aircraft Products, Inc.
2788 Winsted Road
Torrington, CT 06790
Phone: 860.626.7800**

**Allpower Manufacturing Company
13141 Molette Street
Santa Fe Springs, CA 90670
Phone: 562.802.2640**

**Heim Bearings Company
60 Round Hill Road
Fairfield, CT 06824
Phone: 203.255.1512**

**Kahr Bearing
5675 West Burlingame Road
Tucson, AZ 85743
Phone: 520.744.1000**

**Industrial Tectonics Bearings Corporation
18301 South Santa Fe Avenue
Rancho Dominguez, CA 90221
Phone: 310.537.3750**

**RBC West Trenton
400 Sullivan Way
West Trenton, NJ 08628
Phone: 609.882.5050**

**Schaublin SA
Rue de la Blancherie 9
CH-2800
Delémont, Switzerland
Phone: 011.41.32.421.13.00**

**Southwest Products/US Bearing
5001 B Commerce Drive
Baldwin Park, CA 91010
Phone: 626.358.0181**

**Transport Dynamics
3131 West Segerstrom Avenue
Santa Ana, CA 92704
Phone: 714.546.3131**



**RBC Bearings Corporate Headquarters
Oxford, Connecticut U.S.A.**

INDUSTRIAL HERITAGE AND KNOW-HOW

RBC Bearings has a long and impressive history as an innovator in bearing technology – one that has been highlighted by patents for creative engineering design. Today, the company comprises a number of facilities throughout North America and Europe, with a global network of sales engineers, aerospace distributors, and authorized agents. Publicly held (Nasdaq: ROLL), RBC has grown steadily through strategic planning and acquisitions. Since the early nineties, these acquisitions have continued to expand the breadth of an extensive product line of bearings and related products that serve global industries – chief among them, aerospace.

Since its earliest days in West Trenton, New Jersey, the company has been at the forefront of bearing technology. **Roller Bearing Company of America**, founded in 1919, manufactured a variety of bearing products. In 1941, Roller Bearing Company became the sole source supplier for the landing gear bearings on military aircraft manufactured by Ford Motor Company. The RBC facility in West Trenton continues today to be a major supplier of helicopter main and tail rotor flight control bearings to, among others, the U.S. Government.

In 1990, RBC acquired **Industrial Tectonics Bearings (ITB)**. Located in Rancho Dominguez, California, the division was founded in 1955. ITB manufactures custom bearings along with a complete line of thin section ball bearings with capabilities up to 40 inches outside diameter. Typical aerospace applications include engine, gearbox and transmission bearings, helicopter swashplate bearings and electro-optical targeting pods. ITB specializes in the manufacturing of complex, high precision bearings, utilizing special materials and coatings, while serving the aerospace and defense markets.

Transport Dynamics, founded in 1955, and was acquired in 1992. Also located in southern California, Transport Dynamics is one of RBC's main producers of plain bearings, manufacturing journal bearings (bushings), spherical plain, and rod end product with a focus on engine and helicopter applications. Plain bearings at Transport Dynamics are constructed in metal-to-metal and as lined, self-lubricating product. Transport Dynamics offers over 30 different liner systems depending upon the loading, wear, and temperature conditions in the application (including the patented Fibriloid®, Fabroid®, and Fiberglide® liner technology). Transport Dynamics manufactures plain bearing product in both conventional swaged configurations and as load slot entry bearings (Messerschmidt design). Transport Dynamics was actually the inventor of the lined spherical bearing, with the first application developed in 1957 for the Chevrolet Corvette suspension joint. Boeing adopted this new bearing design and soon it was used throughout the 727 model aircraft. Transport Dynamics actually licensed this technology to all their competitors back in the 1960s.

Heim® Bearings, Fairfield, Connecticut, joined the RBC family in 1993. Founded by Louis Heim in 1942, the Heim® name has been known and respected for designing the first integral rod end bearing, specifically the Unibal® spherical bearing rod end. This bearing was originally designed to solve aircraft delivery delays due to critical shortages in rod ends and self-aligning bearings during the war effort. Heim® Bearings Company is also well known for inventing centerless grinding and for inventing the swaging process used in the manufacture of spherical plain bearings. In addition to rod end and spherical bearings, Heim® Bearings Company manufactures specialized radial ball bearings, such as a cobalt race hybrid bearing with silicon nitride balls for a hot bleed air valve application in

aircraft auxiliary power units, suspension applications on Military land vehicles, elastomeric bearings and machinable liner systems. Heim® Bearings Company is also the world's largest provider of aerospace ball bearing rod ends, including manufacture with the corrosion-resistant AeroCres® material. Ball bearing rod ends can be found throughout aircraft in positioning and linkage assemblies, as well as on swaged tubes throughout the airframe.

In 2000, RBC acquired **Schaublin SA** based in Delémont, Switzerland. As a result, RBC added Schaublin's metric rod ends and metric spherical bearings to the family of global RBC products, and a base with which to service the European market. Within this 140,000 sq. ft. facility, RBC has established the company's European Distribution Center. In addition, Schaublin was licensed by Heim® Bearings to market Unibal® rod ends back in the 1950s. Schaublin specializes in light weight titanium bearing solutions, including next level assemblies utilizing integral split ball designs for the aerospace industry. RBC also acquired what is now called **RBC France** — a sales, engineering, marketing, and distribution arm for Schaublin product, located in Les Ulis, France.

In December, 2003, RBC acquired the business of the former Torrington "Standard" Plant — a long-established leader in airframe products. This facility, referred to as **RBC Aircraft Products, Inc. (API)** was founded in 1866. The Torrington name is synonymous with quality engineering and precision — and complements the RBC portfolio of aerospace product offerings. At the API plant, RBC produces aircraft needle track roller bearings, lined track rollers, cam followers, radial ball bearings, and is RBC's main facility for the production of 52100 cad plated, 440C stainless, and zinc nickel plate airframe control ball bearings. RBC has become the number one producer worldwide of airframe control product and has virtually every series and size Mil Spec approval along with an extensive list of European approvals.

RBC has made an additional aerospace business acquisition in each of the years 2004, 2005, and 2006; acquiring **U.S. Bearing**, Chatsworth, California; **Southwest Products Inc.**, Baldwin Park, California; and **Allpower Manufacturing**, Santa Fe Springs, California, respectively. **Southwest Products/US Bearings** has the capability to offer unique swaged bearing solutions (up to 11" OD), in addition to low friction liners and hard coat machining. The product offering has evolved to include split ball spherical and rod ends, large trunnion bearings, specialty rod ends and solid and welded links. SWP/USB has played a major role in the design and support of plain bearings for commercial and military aircraft, helicopter, power plant, satellite, military land vehicle and submarine

applications. **Allpower Manufacturing**, a Boeing and Airbus approved supplier, produces a full line of precision bushings, spacers, sleeves, and specialty machined parts servicing the aerospace industry. Capable of offering specialized materials, All Power is proficient with stainless steel, carbon steel, beryllium copper, Inconel®, titanium, aluminum, aluminum bronze and colbalt raw materials, to name a few.

In December, 2008, RBC acquired **A.I.D. Corporation**, now recognized as **RBC AeroStructures**, located in Westminster, SC. RBC AeroStructures compliments the RBC product offering by producing tight tolerance, precision fabricated tubular and machined parts. With a primary focus on fixed-wing and rotary-wing aircraft, some typical applications include: control rods, push-pull rods, connecting links, torque tubes, rod assemblies, struts and cargo tie-downs. This is a vertically intergrated product line to the already broadest line of aerospace bearings offered by RBC in the industry.

In April, 2015, RBC aquired **Kahr Bearings**, as part of the **Sargent Aerospace and Defense** acquisition. Located in Tucson, AZ, Kahr specializes in the design and manufacture of PTFE lined and metal-to-metal monoball and sliding element bearings for military and commercial aircraft and rotorcraft, industrial and passenger railcars, and military marine applications. Kahr's line of Kahr-Lon® liner systems consists of 10 different liner systems which excel in high vibration and high load environments and are common in many aerospace and industrial applications.

Aerospace Segments Served

Aerospace segments served by RBC include commercial and military alike, fixed and rotary wing. RBC serves the world's major airframers (large transport, regional, and general aviation), engines and accessories, defense (land and marine vehicles, missile and bomb, optical targeting), space (vehicles and engine), major subsystem providers (landing gear, electrical generation, etc.), and smaller subsystem and component applications (primary and secondary flight control actuation, swaged tube bearing, and structural applications, etc.)

RBC's aerospace operations count among their customers a long list of prestigious names, including Airbus, Boeing, Lockheed Martin, SAAB, Northrop Grumman, BAE Systems, Bombardier, Embraer Aircraft, Spirit Aerosystems, NASA, Bell Helicopter, Sikorsky, Boeing Mesa and Rotocrafts, Rolls-Royce, GE Aircraft Engines, Snecma, Pratt & Whitney, Honeywell, ASCO, Goodrich Aerospace, Moog, Smiths Aerospace, Parker Aerospace, Messier-Dowty, Raytheon, Primus University Swage, LeFiell, and Tyee.

The RBC aerospace divisions are well versed in the many bearing materials, from the standard chrome 52100, to the CRES 440C and 15-5/17-4 stainless product, to the processing of exotic materials like ALTEMP® A286*, Stellite®**, titanium, Inconel®***, beryllium copper, Pyrowear®, and AeroCres®.

Combined revenue of the RBC aircraft divisions, is approximately 75% aerospace. The predominant non-aerospace markets include high-end industrial applications requiring the same stringent tolerances and high-quality precision product.

Quality Statement

All of RBC's aerospace bearings divisions have a formal, documented, and aerospace-approved quality program/system in place. The company is approved to many OEM quality systems, including Airbus, Rolls-Royce, Pratt & Whitney, GE Aircraft Engines, Boeing Commercial Aircraft, Boeing Helicopter, Sikorsky, Lockheed Martin, Northrop Grumman, Snecma, Goodrich, BAE Systems, and the U.S. Government, among others. RBC is on a self-release program with many of these companies.

For example, Industrial Tectonic Bearings (ITB), Rancho Dominguez, California, was promoted to Gold Level Preferred Supplier status at Lockheed Martin Missiles and Fire Control, Orlando, Florida. At this point, RBC is the only Gold bearing supplier to the Lockheed organization. In a statement given by a senior manager for Lockheed Martin Missiles and Fire Control, "...the ITB facility is key in helping us create a world-class supply base." To assess ITB's supplier status, Lockheed Martin performed an on-site business system review, the team concluding that RBC demonstrated a dedication to continuous improvement and process improvement. The Gold status allows ITB to perform its own final inspection of hardware, facilitating a "dock-to-stock" receipt at Lockheed Martin's Orlando factory.

All aerospace divisions of RBC are ISO 9001:2008 and AS9100 certified. Additionally, they are NADCAP accredited in-house for non-destructive testing, heat treat, and weld, or are using NADCAP accredited sourcing. The company is constantly audited by the many major aerospace customers in the world, as well as by the FAA. RBC is aware that material, specification, and/or processing changes are all critical. As such, the company has a traceability process for its manufacturing locations including a procedure for preserving the identity and origin of the bearing and all its components. RBC has the capability to isolate and recall suspect bearings from use and trace the cause of failure to a specific manufacturing lot, material process, or component.

Strategic Plan and Vision

RBC Bearings' strategic plan and vision is to continue down the path of profitability and growth — organic growth including market penetration and the addition of new products and growth via acquisition to which RBC's uncompromising track record of aerospace acquisition attests. RBC has become the world's broadest supplier of aerospace bearing product, serving the industry with spherical, rod end, and journal plain bearings, ball bearings, cylindrical roller bearings, needle track roller bearings, cam follower bearings, tapered roller bearings, airframe control, thin section ball bearings, and ball bearing rod ends. RBC is focused on the aerospace industry and intends to continually complement its broad offering with new products, new technologies, and acquisitions.

RBC has a long tradition of engineering design excellence and innovation in creating solutions to problems, as our patents reflect. The company also strives to stay on the forefront of bearing material, plating, and design technology. Investing in qualified personnel, capital equipment, material and bearing testing is paramount. RBC also strives to continually refine its manufacturing processes, both to maintain the reputation for quality product and long life, and to remain the industry's cost leader.

A very important part of our strategic vision is to develop/expand on a current business partnership with targeted customers. RBC's goals, objectives, and investments support the aerospace market, while many companies are choosing to exit the industry. RBC believes that its objectives are soundly aligned with the needs of the aerospace industry, both short and long term. All of us at RBC look forward to supplying more of our aircraft offerings through all the RBC aerospace divisions participating in your business.

Warranty

RBC's sole warranty is against defects in materials or workmanship. The foregoing warranty is exclusive, and in lieu of all other warranties (whether written, oral or implied) including, but not limited to, the warranty of merchantability, and the warranty of fitness for a particular purpose. A no charge replacement will be made on any product manufactured by RBC, which upon examination by RBC, appears to be defective, provided it is returned to RBC, transportation prepaid, within ninety (90) days of date of sale, and further provided it has been properly selected, installed or mounted and lubricated and not subject to abuse.

Pyrowear® is a registered trademark of Carpenter Technology Corporation.

*ALTEMP® A286 is a registered trademark of ATI Allegheny Ludlum.

**Stellite® is a registered trademark of the Deloro Stellite Company, Inc.

***Inconel® is a registered trademark of Alloys International, Inc. and The International Nickel Company, Inc.

CONTACT US**Domestic****Corporate Headquarters**

One Tribology Center
102 Willenbrock Road
Oxford, CT 06478
Phone: 203.267.7001
Fax: 203.267.5012

RBC AeroStructures

123 Commerce Way
Westminster, SC 29693
Phone: 864.886.4601
Fax: 864.886.4615

Aircraft Products, Inc

2788 Winsted Road
Torrington, CT 06790
Phone: 860.626.7800
Fax: 860.626.7886

Allpower Manufacturing Company

13141 Molette Street
Santa Fe Springs, CA 90670
Phone: 562.802.2640
Fax: 562.921.9933

Heim Bearings Company

60 Round Hill Road
Fairfield, CT 06824
Phone: 203.255.1512
Fax: 203.319.7709

Kahr Bearing

5675 West Burlingame Road
Tucson, AZ 85743
Phone: 520.744.1000
Fax: 520.744.9494

Industrial Tectonics Bearings Corporation

18301 South Santa Fe Avenue
Rancho Dominguez, CA 90221
Phone: 310.537.3750
Fax: 310.537.2909

RBC West Trenton

400 Sullivan Way
West Trenton, NJ 08628
Phone: 609.882.5050
Fax: 609.882.5533

Southwest Products Inc./US Bearing

5001 B Commerce Drive
Baldwin Park, CA 91010
Phone: 626.358.0181
Fax: 626.303.6141

Transport Dynamics

3131 W. Segerstrom Avenue
Santa Ana, CA 92704.9998
Phone: 714.546.3131
Fax: 714.545.9885

International**RBC France SAS**

19, Avenue de Norvege
ZA de Courtaboeuf 1
91953 Les Ulis Cedex
France
Phone: 011.33.1.60.92.17.35
Fax: 011.33.1.69.86.12.84

Schaublin SA

Rue de la Blancherie 9
CH-2800 Delémont
Switzerland
Phone: 011.41.32.421.13.00
Fax: 011.41.32.421.1301

INTRODUCTION

The first RBC bearings designed expressly for airframe controls were manufactured in 1929. As pioneers in this field, these early control bearings paved the way for later generations of RBC products which are recognized as design and performance standards by the global aircraft industry.

Over the years RBC has steadily expanded its aircraft line to meet the increasingly exacting demands imposed by newer, larger aircraft and airborne vehicles. This line now offers the widest range of types and sizes available to the aircraft industry. Many of these products have been specifically designed to meet the demands for elevated temperatures, low torque, closer tolerances, compactness, and greatest load capacity to bearing weight ratios.

Although most bearings listed on the following pages are designed primarily for the airframe industry, many have been used successfully in other fields in which the motion is mainly oscillatory. These bearings are manufactured with the high standards of precision and quality synonymous with RBC's reputation throughout the industry.

GENERAL INFORMATION

RBC airframe (or aircraft) control bearings and RBC ball bearing rod ends are manufactured in compliance to U.S. Government and Aerospace Industry Standards and Specifications.

Airframe control bearings and ball bearing rod ends are of lightweight design, corrosion protected, grease-lubricated, and typically sealed. Although designed and manufactured under demanding quality control requirements for airborne systems, these bearings have been successfully used in other fields of application, where motions are mainly oscillatory and/or with limited rotation.

PRECISION

RBC supplies airframe control bearings both in "Standard" and "Precision" series. The prefix "M" in a bearing number indicates that it is of a precision series. RBC supplies ball bearing rod ends as a Precision series.

MATERIAL

Rings and balls are made of hardened bearing alloy, AISI 52100. All exposed surfaces except bearing bore are cadmium or zinc nickel plated for corrosion protection, unless otherwise noted.

For improved corrosion protection, RBC also supplies bearings made of hardened stainless steel alloy, AISI 440C, AMS 5930, or CREN. This alloy may, in addition, be passivated, cadmium plated, or zinc nickel plated for enhanced corrosion protection.

On ball bearing rod ends the outer rod body is made of a selectively hardened AISI 8620 or RBC AeroCres[®] fracture-tough material. AeroCres fracture-tough airframe products use a specialized carburized stainless steel. RBC has developed and optimized the heat treatment process resulting in a homogeneous microstructure — delivering both corrosion protection and core fracture toughness.

PERFORMANCE

Please refer to the individual Engineering Section for specific useful information on bearing performance characteristics as for load rating, installation and application.

Tabulated performance data provided in this catalog are guidelines only. Rotational load ratings listed are calculated assuming intermittent slow rotation. When selecting bearings, the loads, motion modes of oscillation or rotation, and speeds must be taken into account.

We strongly recommend that you consult RBC before finalizing your selection, especially when considering a full complement airframe control or rod end bearing for continuous rotational application.

RBC airframe control and rod end bearings offer the following key design features

- Inch and metric sizes with final as-plated dimensions.
- Corrosion Resistance available with stainless steel and/or cadmium plated alloy steels on all exposed surfaces except bore and seals. RBC also offers other corrosion resistant plated materials, which include zinc nickel plated alloy steels and RBC AeroCres[®] fracture-tough airframe products.
- High load capacities in a compact, lightweight design.
- Inert polytetrafluoroethylene (PTFE) —Teflon[®]— seals standard on most sizes.
- Extended inner rings eliminate the need for spacers.
- Bearings with suffix FS428 are prepacked with lubricant conforming to specification MIL-PRF-23827, Type 1 and BMS3-33 and are equipped with PTFE seals.

- Bearings with suffix FS464 are prepacked 80% to 100% with lubricant conforming to specification MIL-PRF-81322 and are equipped with PTFE seals.
- Most self-aligning designs permit up to 10° misalignment in either direction.
- RBC airframe control ball bearings conform to SAE-AS7949 (formerly MIL-B-7949) and all major OEM specifications.
- RBC ball bearing rod ends conform to SAE-AS6039 (formerly MIL-B-6039) and OEM specifications.
- NSA ball bearing rod ends.

U.S. GOVERNMENT SPECIFICATIONS

It should be noted that all bearings listed in this section, whether covered by military specification or not, are manufactured to the same high standards of quality and reliability. RBC's objective is to engineer and fabricate control bearings which will meet and exceed the customer's needs, however exacting they may be. By utilizing the latest technology in bearing design and manufacture, RBC surpasses standards set by military specifications. Keeping abreast of advances in the field is RBC's assurance that RBC bearings will be available to fill the most demanding performance requirements as flight vehicles of the future become reality.

SAE-AS7949 SPECIFICATIONS

The airframe control bearings listed on the following pages are manufactured in accordance with the U.S. Government standards as set forth under the appropriate military specifications. The government specification covering the largest number of bearings is SAE-AS7949. Standards applicable under this specification and the bearing series to which they apply are shown in Table 1 below.

SAE-AS6039 SPECIFICATIONS

The rod end bearings listed on the following pages are manufactured in accordance with the U.S. Government standards as set forth under the appropriate military specifications. The government specification covering the largest number of bearings is SAE-AS6039. Standards applicable under this specification and the bearing series to which they apply are shown below:

- MS21150REP-SSolid Shank Rod End
- MS21151REP-MMale Rod End
- MS21152REP-HHollow Shank Rod End
- MS21153REP-FFemale Rod End

Two additional groups of rod ends, referred to as the "Balanced Design" series, are manufactured to meet the National Aircraft Standards Specification NAS661. Under this specification Balanced Design rod ends conform to standards NAS659 and NAS660.

Table 1

RADIAL PLAY AND GREASE VARIATIONS FOR SAE-AS7949 BEARINGS

MS Series	RBC Series	Standard Radial Play MIL-PRF-81322 Grease		Reduced Radial Play MIL-PRF-81322 Grease		Standard Radial Play MIL-PRF-23827, Type 1 Grease		Reduced Radial Play MIL-PRF-23827, Type 1 Grease	
		MS Suffix	RBC Suffix	MS Suffix	RBC Prefix/Suffix	MS Suffix	RBC Suffix	MS Suffix	RBC Prefix/Suffix
27640	KP								
27641	KP-A	NONE	FS464	R	M/FS464	G	FS428	RG	M/FS428
27643	DSP								
27645	KSP								
27644	DPP								
27646	B500DD								
27648	KP-BS	NONE	FS464	NA	NA	G	FS428	NA	NA
27649	AW-AK								
21428	MB500DD								
21443	P, KP-K								
27647	DW	NONE	FS464	R	M/FS464	L	M/FS464	RL	M/FS428
27642	KP-B(1)			S ⁽¹⁾	FS464	G		SG ⁽¹⁾	FS428

⁽¹⁾ MKP-B Series are used for MS27642 bearings with an S or SG suffix (MS27642-16S is RBC MKP16B FS464)

AIRFRAME CONTROL & ROD END BEARINGS

Bearings listed herein are tabulated in two groups: (1) full complement bearings, which have no separators (retainers or cages); and, (2) bearings with separators (retainers or cages). The full complement bearings and concave roller bearings should be used in applications where the motion is mainly oscillatory; whereas, the bearings with ball separators may be used in applications where the motion may be continuous rotation or oscillatory under relatively light loads.

Airframe Control Full Complement (No Cage) Bearings

KP, MKP, AMKP Series
 KP-A, MKP-A, AMKP-A Series
 KSP, MKSP, AMKSP Series
 KSP-A, MKSP-A, AMKSP-A Series
 KP-B, MKP-B, AMKP-B Series
 KP-BS, MKP-BS, AMKP-BS Series
 DPP Series
 DPP-W Series
 DSP, MDSP Series
 DSRP, GDSRP Series
 DW (except DWK, DWK2 and MDW-K), AMDWK Series
 GDW (except GDW4K and GDW4K2)
 B500DD, MB500DD, AMB500DD Series
 B500, MB500, AMB500 Series
 B5500WZZ Series
 P8 Pulley Series
 K Series, D Series

Rod End Full Complement (No Cage) Bearings

REP Series
 RAP Series
 RA Series (NAS659)
 RR Series (NAS660)

Airframe Control Bearings with Separators

AW-AK Series
 DW4K and DW4K2 Series
 GDW4K and GDW4K2 Series
 KP-K Series
 P Series (except P8)
 BCP Bell Crank Series
 HGS Series

STANDARDS OF QUALITY

All RBC bearings are manufactured to the same high standards of quality and reliability. RBC strives to engineer and utilize the latest available manufacturing technologies for producing bearings which meet and exceed all existing customer standards and expectations. This is RBC's assurance that its bearings will be available to fill the most demanding performance requirements in a variety of applications.

BEARING SELECTION, KEY CONSIDERATIONS

When selecting bearings, the primary focus should be on application requirements. Once the application requirements are clearly understood and specified, selecting bearing type and design is relatively straightforward. What are the main application requirements for bearings? Loads (radial, axial, moment, and magnitude), motion (oscillatory, rotating, or intermittent), speed (fast or slow), bearing life requirements (long or short), operating temperature (hot or cold), and operating medium (clean or contaminated air, water, vacuum, etc.) are among key application requirements. Depending on combination and severity of such factors, an RBC Aerospace Bearings sales engineer can offer guidance in selecting bearings for optimum service in the application.

As an aid in the preliminary stages of bearing selection, but not as a substitute for the services of a skilled bearing engineer, the following points are listed for the guidance of designers and inspectors:

1. If the bearing is used for continuous rotation, or in a delicate instrument application, do not consider any of the control type series, such as KP, KP-A, KP-B, KSP, DPP, DSP, HGS, etc., but refer to standard radial bearings or other more specialized types listed in other RBC catalogs.
2. All control surface hinge bearings should be of the sealed type. The sealed type is recommended on installations exposed to salt water spray, aircraft cleaning solutions, and where subjected to severe dust or dirt. Bearings having no shields or seals should be completely enclosed by the housing in which they are mounted to provide protection against external contaminants from entering the bearing and prevent lubricant inside from migrating or escape out of the bearing.
3. Airframe control self-aligning bearings of the KSP series are intended to compensate for misalignment due to initial setup and deflection in structure. They

should not be used as rod end bearings in non-planar linkages. For such applications, the DSP, DSRP or HGS series should be considered.

4. Bearing design intent and installation guidelines should be followed closely. Due consideration should be given to how a bearing would perform as installed and loaded in the next level assembly, as opposed to how it performs during free-state handling. Inspectors, therefore, should not reject KSP, DSP, DSRP or HGS series bearings because of tightness and/or roughness when the bearing is spun in a misaligned position. A study of the internal design will show that in pure misalignment (not accompanied by rotation) the rolling elements do not roll, but skid across the rolling elements raceway due to their wedging action. Any inspector's insistence that bearings be loosely fitted to ensure ease of misalignment would be unjustified and might cause flutter because of sloppy controls. A reasonable amount of tightness in self-aligning bearings (not excess binding) will ensure the desired rigidity in the control linkage system. Please adhere to instructions on shaft and housing fits provided in this catalog.
5. On applications in which a pair of bearings is assembled in a housing, such as on a bell crank pivot, for example, the following considerations are vital to satisfactory service:
 - a. Bearings should not be preloaded when the nut is tightened up on the bolt or shaft supporting the two bearings.
 - b. Ensure concentricity of bearing seats in the housing to avoid binding of bearing with respect to each other, when the bolt is passed through. As rule of thumb, to prevent premature bearing failures, the size and form precision of the supporting housing and shaft should be comparable to those of the bearing itself.

Questions concerning information in this section should be directed to the appropriate RBC Aerospace Bearings sales engineer.

LOAD RATINGS, LIMIT, AND STATIC RATINGS

The limit load ratings published in this catalog for airframe control bearings are the product of a special study undertaken jointly in 1949 by the Bureau of Aeronautics, the United States Air Force, the National Aircraft Standards Committee (NASC), and the American Bearing Manufacturers Association (ABMA). The purpose

of this study was to develop a system for rating airframe control bearings based on criteria that would simulate more closely conditions encountered in real flight.

The basic equation is:

$$\text{Limit load rating} = Knd^2$$

where K = Load rating constant

n = Number of balls

d = Ball diameter

Typical K factors for radial limit load ratings are about 10,000 for deep groove bearings, 4800 for single row self-aligning bearings, 3800 for double row self-aligning bearings and 3200 for rod end bearings. In no case does the limit load rating exceed two-thirds of the bearing's minimum static fracture strength. That is, the minimum static fracture strength is 1.5 times the limit load rating.

OSCILLATING LOAD RATINGS

For bearing life and load calculations under oscillating conditions, consult an RBC Aerospace Bearings sales engineer.

Full complement type bearings should not be used for rotating applications either intermittent or continuous. If it becomes necessary to consider these bearings in such applications, consult an RBC Aerospace Bearings sales engineer prior to making selections.

An oscillating load rating system was accepted by AFBMA as an unpublished standard in 1959.

This standard permits selection of the smallest bearing that will operate under the normal loading for the desired life. This data is presented as tables of radial load ratings for 10,000 complete 90° oscillatory cycles. The 90° angle was selected as typical, a good value for test work, and conservative for bearing selection until more data is accumulated on the effect of various angles of oscillation. Rating are given for:

- Case I: where the load is fixed with respect to the outer race (inner ring oscillation)
- Case II: where the load is fixed with respect to the inner race. (outer ring oscillation)

Radial load ratings for any other number of oscillatory cycles may be readily obtained by multiplying the basic 10,000 cycle rating by a life factor obtained from a life factor curve.

The formulas for the ratings and life factors were derived from data accumulated by testing many bearings of different sizes and types under several different radial loads.

Briefly then, in selecting a bearing there are two steps:

1. Select a bearing that has a radial limit load rating equal to or in excess of application limit load.
2. Check the oscillatory rating of this bearing to ensure that the desired average life will be obtained under the normal loading.

In actual service, the load on any control position varies as the number of times the various loads are applied. Knowing the different loads and their duration, it is possible to calculate one equivalent load that would give the same number of cycles average life as the various loads. No one load may be greater than the limit load rating of the bearing. The equivalent load may be calculated from the formula:

$$P = [\sum K_i (P_i)^{3.6}]^{1/3.6}$$

where P = Equivalent load – Pounds or Newtons

P_i = Actual applied load – Pounds or Newtons

K_i = Proportion of service time that P_i is applied

For example, suppose a particular application carries a radial load of 500 lbs. for 15% of the total service time, 1000 lbs. for 75% and 2000 lbs. for 10%. Then the equivalent load on this bearing is:

$$P = [.15(500)^{3.6} + .75(1000)^{3.6} + .10(2000)^{3.6}]^{1/3.6} = 1208 \text{ lbs.}$$

The tabulated values shown in various load rating tables will give an average life of 10,000 complete oscillatory cycles for two conditions of operation. Case I values are for bearing capacities with the load fixed with respect to the outer race. Case II values are for loads fixed with respect to the inner race.

A Life Factor Chart is provided to determine bearing capacity for an average life greater than 10,000 cycles and is used with the load rating tables. The life factor for the required average life is taken from the chart. The Case I or Case II rating of the bearing is then multiplied by this life factor. This product is the load which the bearing can carry to give the required average life. For life requirements of less than 10,000 cycles, we advise using the 10,000 cycle rating. Beyond this point, the criteria that determined this graph do not remain constant.

The proportionate amount of time that the various service loads are carried by a bearing can best be determined by the designer, who is familiar with the type of aircraft under consideration. With accumulated experience it is expected that shortcuts in using this method of bearing selection will be developed for each type of aircraft.

Following are typical examples of bearing selection based upon the procedure described previously.

Example 1

Taking the 1208 lb. equivalent load (above) in an application in which the heaviest of three radial loads is 2000 lbs., we can proceed through the KP and KP-A Series locating the smallest acceptable bearing as follows:

If there is no oscillatory life requirement stated and set-up of an overhaul period according to oscillatory life indicated, then proceed through the KP Series until the KP4 is reached, which is the first size having a radial limit load rating exceeding 2000 lbs. (2680 lbs.) and Case II rating 2030 lbs. Both of which exceed the 1208 lb. equivalent. The average oscillatory life for 1208 lbs. on a KP4 for Case I condition is 120,200 cycles for a Life Factor of $1208/2410 = .501$. The average oscillatory life for 1208 lbs. on a KP4 for Case II condition is 64,700 cycles for a Life Factor of $1208/2030 = .595$. The overhaul schedule can be set up for these average lives or on the basis of one-fifth of these lives for minimum life (90% survival).

Similar procedure in the KP-A Series shows KP5A as the smallest acceptable size with an average life of 43,700 cycles for Case I and 27,500 cycles for Case II. Minimum life is again one-fifth of these average life values.

Example 2

For another case, keep this 1208 lb. equivalent load and 2000 lb. maximum load and select a bearing which would have a Case I average life requirement of 690,000 cycles. The Life Factor to give this life is .309 or the Case I range must exceed 3910 (from $1208/.309$). A KP5 or KP10A are the smallest bearing sizes in these series to satisfy this condition.

RATED RADIAL CAPACITIES

The rated radial capacities for complete rotation given in this catalog are based on AFBMA Standard Section 9, Method of Evaluating Load Ratings for Ball Bearings. The Life Basis is for 2500 hours average life at 100,300 and 500 rpm. For other Life Basis and/or speed conditions, consult an RBC Aerospace Bearings sales engineer.

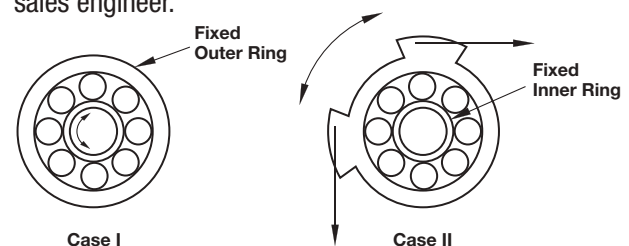

LIFE FACTOR CHART*

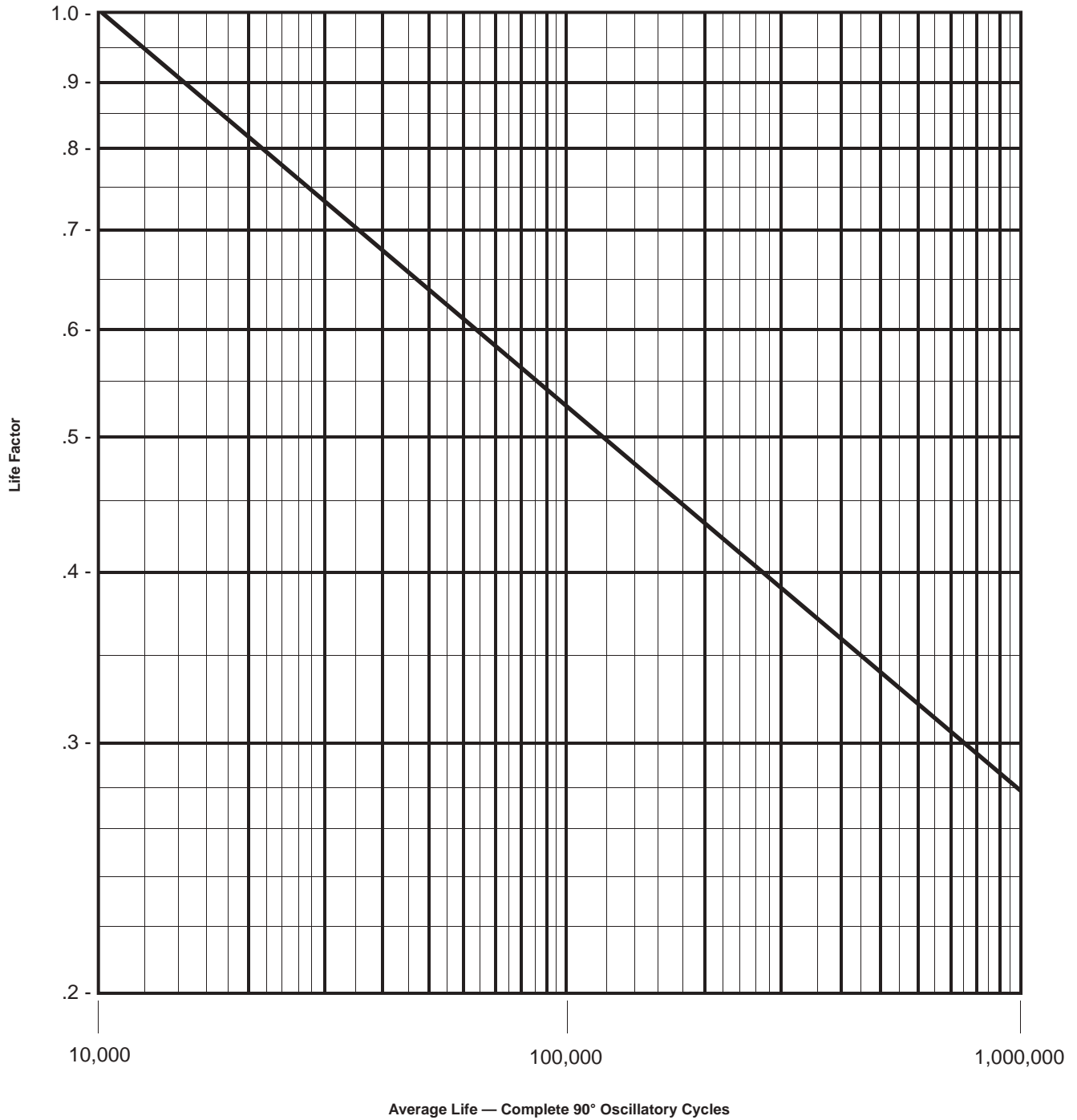

*Excluding concave roller series

AIRFRAME CONTROL
& BALL BEARING
ROD ENDS

EXAMPLES OF BEARING SELECTION UNDER COMBINED LOADING CONDITIONS

Equivalent Limit Load – Combined Loading

When radial load, thrust load and moment load are encountered in combination (all three or any two) on a single bearing mounting, an equivalent thrust limit load is obtained and the customer can select an airframe bearing of a size having a thrust limit rating exceeding the equivalent thrust load. This is for static conditions and disregards life requirements under oscillation.

The formula for an individual size of bearing follows here and footnotes under various series tables give approximations for sizes within a series with applicable approximate ratios of ratings given:

$$\begin{aligned} \text{Equiv. thrust load} = & \\ \frac{\text{Thrust limit load rating}}{\text{Radial limit load rating}} & \times \text{Radial load} \\ & + \text{Thrust load} + \text{Moment constant} \\ & \times \text{Moment in inch pounds} \end{aligned}$$

As an example on a KP6A bearing

$$\begin{aligned} \text{Equiv. thrust load} = & (1100/2500) \times \text{Radial load} \\ & + \text{Thrust load} + 7.68 \times \text{Moment} \end{aligned}$$

Note that it is necessary to be dealing with a certain bearing size especially when moment is involved, and trial sizes are chosen having pure moment ratings larger than moment load involved to leave the capacity to be absorbed by radial and thrust components. If moment load is a big part of the loading, then it is necessary to select a bearing from a series having good moment ratings. When only radial and thrust loads are present, the problem is not so involved as any certain series has a fairly constant ratio of radial and thrust limit load ratings.

COMBINED LOADS INCLUDING MOMENT LOADS FOR SINGLE AND DOUBLE ROW BEARINGS

Note that the dynamic thrust load should not exceed 60% of the applied radial load for a full type bearing.

To illustrate the use of the moment constants given in the load rating tables, here are two typical calculations.

Using the safety factor formula:

$$\text{Safety factor} = \frac{\text{Static thrust}}{\text{Equivalent thrust load}}$$

Problem 1

We want to figure the equivalent thrust load and the safety factor on a KP10 (single row) bearing in an application where the radial load imposed is 4000 lbs., the thrust load is 200 lbs., and the overturning moment load is 425 in. lbs.

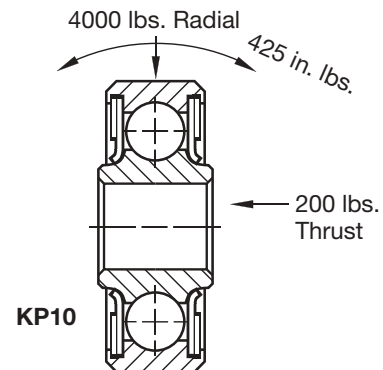

Substituting in the formula:

$$\begin{aligned} \text{Equivalent thrust load} &= (.44 \times 4000 \text{ lbs.}) + 200 \text{ lbs.} \\ &+ (4.09 \times 425 \text{ in. lbs.}) = 3698 \text{ lbs.} \\ \text{Safety factor} &= (6200 \text{ lbs.}/3698 \text{ lbs.}) = 1.68 \end{aligned}$$

Problem 2

Consider a DPP8 (double row) bearing in an application where the loads imposed are as follows: 1000 lbs. radial load, 350 lbs. thrust load and an overturning moment load of 130 in. lbs.

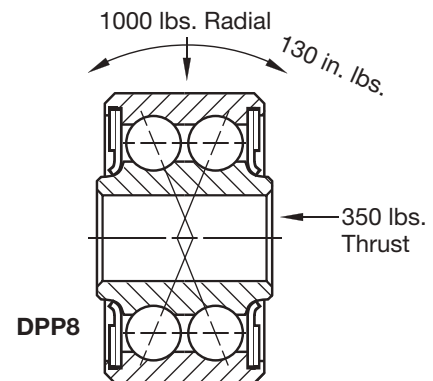

Substituting in the formula:

$$\begin{aligned} \text{Equivalent thrust load} &= (.3 \times 1000 \text{ lbs.}) + 350 \text{ lbs.} \\ &+ (13.2 \times 130 \text{ in. lbs.}) = 2366 \text{ lbs.} \\ \text{Safety factor} &= (7800 \text{ lbs.}/2366 \text{ lbs.}) = 3.30 \end{aligned}$$

TORQUE

Torque in rolling element bearings can be conveniently classified under two headings: inherent torque and induced torque.

Inherent Torque

The first, inherent torque, is the cumulative effect of the following factors:

Geometry: Surface finish of mating parts, deviations from roundness in the races, ball sphericity, and tolerances between functional surfaces.

Internal fit-up: Race curvatures, contact angle, radial internal clearance, and number of rolling elements.

Bearing type: Full complement, radial or angular contact, type of retainer, shields, and seals, if any.

Lubricant: Type and quantity.

The term “inherent torque” is used to emphasize the nature of the torque due to the above causes. While the amount of torque in inch-ounces or gram-centimeters varies according to the degree of precision exercised in the manufacture of a bearing, a certain mean value is attained for each set of conditions, and that level of torque cannot practically be further reduced. The actual no-load, slow-speed inherent torque is very small compared with the torque induced by external causes during operation. At best, inherent torque is a comparative quality for bearing evaluation. Therefore, it is often measured with only a few drops of oil in the bearing. It is controlled almost entirely by the manufacturer, rather than by the customer.

Induced Torque

The second category, induced torque, is the cumulative effect of the following factors, all of which are external in origin to the bearing:

Loads: Both the magnitude and direction of the loads.

Speeds: The variation of, and maximum rpm.

Fits: The shaft and housing fits, plus the alignment of shaft and housing.

Temperature: The effect on fits and lubricant properties.

Contamination: Both foreign matter that enters the bearing and by-products of lubricant breakdown within the bearing.

The term “Induced Torque” as used herein denotes torque resulting from the method of bearing operation and its environment. With the exception of very lightly loaded, slow-speed applications, induced torque far exceeds inherent torque in a ball bearing, by a factor of 50 or more. The customer, therefore, has the final control over how much torque the bearings he uses will exhibit. Reduction of induced torque is primarily the customer’s responsibility.

Design Criteria

The designer or engineer who strives to achieve the lowest economical torque must begin this task before placing the order. The bearing manufacturer can furnish bearings with minimum inherent torque and the least potential for induced torque only if a complete description of the application is made available. Such description will include the following:

Speeds: Maximum; normal; acceleration, if it is rapid.

Loads: Radial, axial or moment loading; magnitude; and relation to speed when possible.

Temperature: Minimum; maximum; normal operating; duration at extremes; shut-down conditions if soak-back is involved when the bearing is stationary; loads during high temperatures.

Lubrication: Whether grease or oil is required; if a circulating or splash-feed oil system is used, accurate determination of the quantity of oil available.

Materials: Specification of shaft and housing material and configurations (i.e., wall thickness, hollow, solid or splined shaft).

Environment: Specify if air, hot gases, fluids, dust, mud, etc. If a foreign substance, either a liquid or slurry, is present, indicate whether it is present continuously or only as a spray or occasional splashing.

Frequently, an inquiry for a ball bearing application includes most of the above, but no drawing accompanies the data. Both a drawing and a complete description as outlined above are required to properly specify the bearing to be used.

Shaft and Housing Fits

Once the bearings are ordered, the designer must ensure that the mating components are consistent with requirements. Housing and shaft fits must be held within specified limits while maintaining close control on roundness for these two dimensions. Interference fits directly affect the internal clearance in ball bearings — as much as 50% to 80% of the interference translates into reduced radial internal clearance, depending on the size of the bearing involved. Paralleling this situation, unequal heating of the inner and outer rings can have the same effect. Frequently, both conditions exist simultaneously; a press fit on the shaft, and higher shaft temperatures than housing temperatures. The result can be an increase in bearing torque or even complete failure due to damage caused by internal interference. Heat soak-back can also damage bearings due to thermal expansion occurring while the bearing is not rotating.

Effect of Low Temperature

Very low temperature conditions can also cause torque to increase sharply. The increase results from a change in housing fits due to thermal contraction and is very pronounced with dissimilar metals such as aluminum housings and steel bearings. There is also a marked increase in lubricant viscosity, particularly with greases. An example is found in aircraft control bearings, which are frequently mounted in aluminum housings and sealed with a quantity of grease enclosed. During ground handling and take-off, there is no detrimental torque in the bearings. However, during extended cruise at altitudes where the air temperature drops to -65°F (-54°C) or lower, the bearing may be literally frozen, due to interference and/or stiffened lubricant. After returning to more normal temperatures, the bearing may operate satisfactorily if only the stiff grease caused it to freeze; however, if the housing interference was excessive, and the races are brinnelled, subsequent operation will be rough and noisy.

Misalignment

Misalignment of the rotating member and the housing can cause high torque by applying a preload as the balls travel from one side of the race to the other during each revolution of the bearing. At sustained speeds, there is also a temperature rise, and the possibility of exceeding the load capacity of the lubricant. This condition, if self-sustaining, rapidly worsens to the point of bearing failure.

Loading

Torque in bearings increases directly as a function of load: either radial, axial, or a combination of the two. When loads are substantial, the designer should allow for the largest bearing possible, consistent with overall requirements early in the design stage. High torque due to loading cannot be significantly reduced for a given size bearing.

Seals

In applications where low speeds or oscillation are involved and where seals are needed to protect the bearing and retain lubricant, it is essential that information relative to contaminants be included with the description of the application. A variety of materials is available for seals; however, each one is unique in its ability to resist chemical attack by lubricants, hydraulic fluids, etc., and in its physical characteristics such as flexibility. For a particular condition of temperature, lubricant, and outside contamination, there is usually only one specific seal material that will best satisfy all requirements. The standard seal material used in the RBC airframe control and rod end bearings is PTFE.

STARTING TORQUE LEVELS

Proper interpretation of the graph on page 16 on starting torque levels under radial loads requires that the user keep the following limitations in mind. The values were obtained under laboratory conditions with controlled fits, pure radial loading, and at room temperature. Therefore, the torque values are probably lower than those expected in airframe installations. The numerous other external factors that contribute to induced torque, as previously discussed, are not accounted for in the chart. For example, the effect of low temperature on starting torque due to grease stiffness varies widely. A KP3A bearing may show a 100% increase in starting torque at -65°F (-54°C), whereas a KP47B may show only about 10% greater torque, when both bearings are radially loaded to 75% of their rated capacity. Interference fits in housings, differential thermal expansion and contraction of steel bearings and aluminum housings, thrust loads, moment loads, etc., will all add significantly to the chart values for starting torque.

For applications in which low torque is critical, consult an RBC Aerospace Bearings sales engineer for recommendations, giving full particulars of the application.

STARTING TORQUE CHART

Note: This chart is intended only as a guide.

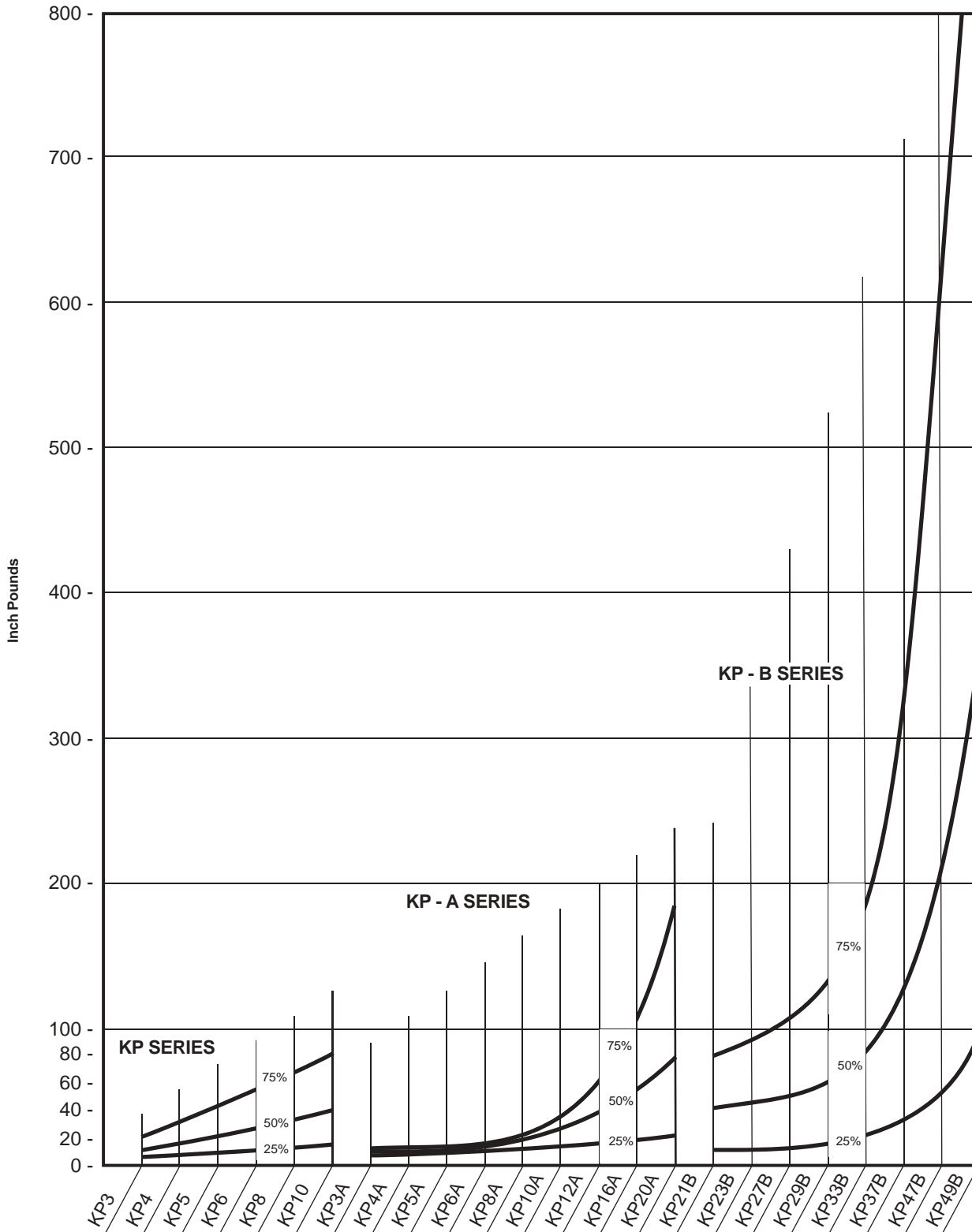

Representative Starting Torque Levels at 25%-50% and 75% of Radial Limit Load:
KP, KP-A, and KP-B Series

© 2008, 2011, 2018 RBC Bearings Incorporated. All rights reserved.

AIRFRAME CONTROL & BALL BEARING ROD ENDS

SHAFT AND HOUSING FITS FOR AIRFRAME BEARINGS

It is essential for proper operation that small, heavily loaded bearings in oscillating service be mounted in housings with a light, but positive, interference (press) fit. Staking or spinning of the housing over the outer ring chamfer is recommended to secure the bearing axially. In some applications involving considerable thrust load, a housing shoulder is desirable.

Minimum and Maximum Fits

The minimum and maximum press fits shown in the following tables represent a compromise condition. Actually, the optimum press fit is approximately .0005 in., .013mm for steel and approximately .0007 in., .018mm for aluminum or magnesium. However, since the bearing outside diameter tolerance is .0005 in., .013mm and a housing bore tolerance of .0005 in., .013mm is the least which can be maintained by usual manufacturing practice, a total possible range of fit of .0010 in., .025mm results. The average outside diameter pressed into the average housing bore results in a press fit range of approximately .0006 in., .015mm; namely, for steel .0002 in. - .0008 in., .005mm - .020mm and for aluminum or magnesium .0005 in. - .0010 in., .013mm - .025mm. Housing bores should not be allowed to run consistently to the low side of the tolerance, as this will obviously increase the average interference and raise the percentage of extreme fits.

Radial Clearance

In all but specially assembled aircraft bearings, a small amount (less than .0010 in., .025mm) of radial clearance is provided between balls and races. When the outer ring is press-fitted into a housing, a portion of

the interference is absorbed by contraction of the outer ring, the balance by the expansion of the housing – the proportions, depending on the relative sections, and the modulus of elasticity of the material.

When the press fit becomes too heavy, the initial radial clearance in the bearing may be removed, resulting in a radially preloaded bearing. Such preloading lessens the capacity of the bearing for applied loads. Hence, excessive press fits should be carefully avoided.

Mean Fits (Tight or Loose)

The expected mean fits listed in the tables result when bearings are mounted on shafts and in housings having the recommended diameters. In the manufacture of ball bearings, most of the bores and outside diameters are near the mean diameter of the tolerance. Similarly, the majority of shafts and housings are held to diameters near the mean of the recommended tolerances. Experience has shown that when standard bearings are mounted on shafts and in housings, the diameters of which are held to recommended tolerances, 85% to 90% of the assemblies will be close to the mean expected fits, and less than 2% will be near the extremes for tightness and looseness.

Although selective assembly is not feasible in most aircraft plants, when extreme fits are encountered, as evidenced by pronounced drag in bearing rotation after mounting, it is recommended that the bearing be removed and fitted to a slightly larger housing bore. This is seldom necessary with rigid type bearings, but may be desirable with self-aligning bearings.

SHAFT AND HOUSING FITS FOR OSCILLATORY SERVICE AW-AK, KP, KP-A, KSP, KSP-A, DPP, DPP-W, DSP, DSRP, GDSRP, DW, GDW, P SERIES

Housing Fits – Standard Series

Bearing O.D.		Steel Housing Bore		Mean Fit Tight		Aluminum or Magnesium Housing Bore		Mean Fit Tight	
in.	mm	in.	mm	in.	mm	in.	mm	in.	mm
0.6250	15.875	0.6245	15.862	0.0005	0.013	0.6243	15.857	0.0007	0.018
0.6245	15.862	0.6240	15.849			0.6238	15.844		
0.7500	19.050	0.7495	19.037	0.0005	0.013	0.7493	19.032	0.0007	0.018
0.7495	19.037	0.7490	19.024			0.7488	19.019		
0.7774	19.746	0.7769	19.733	0.0005	0.013	0.7767	19.728	0.0007	0.018
0.7769	19.733	0.7764	19.720			0.7762	19.715		
0.8125	20.638	0.8120	20.625	0.0005	0.013	0.8118	20.620	0.0007	0.018
0.8120	20.625	0.8115	20.612			0.8113	20.607		
0.8750	22.225	0.8745	22.212	0.0005	0.013	0.8743	22.207	0.0007	0.018
0.8745	22.212	0.8740	22.199			0.8738	22.194		
0.9014	22.896	0.9009	22.883	0.0005	0.013	0.9007	22.878	0.0007	0.018
0.9009	22.883	0.9004	22.870			0.9002	22.865		
0.9375	23.812	0.9370	23.800	0.0005	0.013	0.9368	23.795	0.0007	0.018
0.9370	23.800	0.9365	23.787			0.9363	23.782		
1.0625	26.988	1.0620	26.975	0.0005	0.013	1.0618	26.970	0.0007	0.018
1.0620	26.975	1.0615	26.962			1.0613	26.957		
1.1250	28.575	1.1245	28.562	0.0005	0.013	1.1243	28.557	0.0007	0.018
1.1245	28.562	1.1240	28.546			1.1238	28.544		
1.1875	30.162	1.1870	30.149	0.0005	0.013	1.1868	30.145	0.0007	0.018
1.1870	30.149	1.1865	30.136			1.1863	30.132		
1.2500	31.750	1.2495	31.737	0.0005	0.013	1.2493	31.732	0.0007	0.018
1.2495	31.737	1.2490	31.724			1.2488	31.719		
1.3750	34.925	1.3745	34.912	0.0005	0.013	1.3743	34.907	0.0007	0.018
1.3745	34.912	1.3740	34.899			1.3738	34.894		
1.4375	36.512	1.4370	36.499	0.0005	0.013	1.4368	36.495	0.0007	0.018
1.4370	36.499	1.4365	36.486			1.4363	36.482		
1.6250	41.275	1.6245	41.262	0.0005	0.013	1.6243	41.257	0.0007	0.018
1.6245	41.262	1.6240	41.249			1.6238	41.244		
1.6875	42.862	1.6870	42.849	0.0005	0.013	1.6868	42.845	0.0007	0.018
1.6870	42.849	1.6865	42.836			1.6863	42.832		
1.9375	49.212	1.9370	49.199	0.0005	0.013	1.9368	49.195	0.0007	0.018
1.9370	49.199	1.9365	42.186			1.9363	49.182		
2.0000	50.800	1.9995	50.787	0.0005	0.013	1.9993	50.782	0.0007	0.018
1.9995	50.787	1.9990	50.774			1.9988	50.769		
2.2500	57.150	2.2495	50.137	0.0005	0.013	2.2493	57.132	0.0007	0.018
2.2495	57.137	2.2490	57.124			2.2488	57.119		

Shaft Fits – Standard Series

For oscillating service in which bearings are not mounted on standard aircraft bolts, and are not clamped axially on shafts, it is recommended that shaft diameters from nominal bearing bore size -0.0005 in. (-0.013 mm) to nominal bearing bore size -0.0010 in. (-0.025 mm) be used.

SHAFT AND HOUSING FITS FOR OSCILLATORY SERVICE MKP, MKP-A, MKSP, MKSP-A, MDPP, MDSP, MDW(K) SERIES

Housing Fits – Precision M Series

Bearing O.D.		Steel Housing Bore		Mean Fit Tight		Aluminum or Magnesium Housing Bore		Mean Fit Tight	
in.	mm	in.	mm	in.	mm	in.	mm	in.	mm
0.6250	15.875	0.6246	15.865	0.00045	0.0115	0.6244	15.860	0.00065	0.0165
0.6246	15.865	0.6241	15.852			0.6239	15.847		
0.7500	19.050	0.7496	19.040	0.00045	0.0115	0.7494	19.035	0.00065	0.0165
0.7496	19.040	0.7491	19.027			0.7489	19.072		
0.7774	19.746	0.7770	19.736	0.00045	0.0115	0.7768	19.731	0.00065	0.0165
0.7770	19.736	0.7765	19.723			0.7763	19.718		
0.8125	20.638	0.8121	20.628	0.00045	0.0115	0.8119	20.622	0.00065	0.0165
0.8121	20.628	0.8116	20.615			0.8114	20.609		
0.8750	22.225	0.8746	22.215	0.00045	0.0115	0.8744	22.210	0.00065	0.0165
0.8746	22.215	0.8741	22.202			0.8739	22.197		
0.9014	22.896	0.9010	22.886	0.00045	0.0115	0.9008	22.880	0.00065	0.0165
0.9010	22.886	0.9005	22.873			0.9003	22.867		
1.0625	26.988	1.0621	26.978	0.00045	0.0115	1.0619	26.972	0.00065	0.0165
1.0621	26.978	1.0616	26.965			1.0614	26.959		
1.1250	28.575	1.1246	28.565	0.00045	0.0115	1.1244	28.560	0.00065	0.0165
1.1246	28.565	1.1241	28.552			1.1239	28.547		
1.2500	31.750	1.2496	31.740	0.00045	0.0115	1.2494	31.735	0.00065	0.0165
1.2496	31.740	1.2491	31.727			1.2489	31.722		
1.3750	34.925	1.3746	34.915	0.00045	0.0115	1.3744	34.910	0.00065	0.0165
1.3746	34.915	1.3741	34.902			1.3739	34.897		
1.4375	36.512	1.4371	36.502	0.00045	0.0115	1.4369	36.497	0.00065	0.0165
1.4371	36.502	1.4366	36.489			1.4364	36.484		
1.6250	41.275	1.6246	41.265	0.00045	0.0115	1.6244	41.260	0.00065	0.0165
1.6246	41.265	1.6241	41.252			1.6239	41.247		
1.6875	42.862	1.6871	42.852	0.00045	0.0115	1.6869	42.847	0.00065	0.0165
1.6871	42.852	1.6866	42.839			1.6864	42.834		
1.9375	49.212	1.9371	49.202	0.00045	0.0115	1.9369	49.197	0.00065	0.0165
1.9371	49.202	1.9366	49.189			1.9364	49.184		
2.0000	50.800	1.9996	50.790	0.00045	0.0115	1.9994	50.785	0.00065	0.0165
1.9996	50.790	1.9991	50.777			1.9889	50.782		
2.2500	57.150	2.2496	57.140	0.00045	0.0115	2.2494	57.135	0.00065	0.0165
2.2496	57.140	2.2491	57.127			2.2489	57.122		

Shaft Fits – Precision M Series

For oscillating service in which bearings are not mounted on standard aircraft bolts, and are not clamped axially on shafts, it is recommended that shaft diameters from nominal bearing bore size $-.0003$ in. ($-.008$ mm) to nominal bearing bore size $-.0008$ in. ($.020$ mm) be used.

SHAFT AND HOUSING FITS FOR OSCILLATORY SERVICE (M)*KP-B, (M)*KP-BS SERIES

Bearing Number	Shaft Fits						Housing Fits										
	Bearing Bore		Steel, Aluminum or Magnesium Shaft		Mean Fit Loose		Bearing O.D.				Steel, Aluminum or Magnesium Housing		Mean Fit Loose				
	in.	mm	in.	mm	in.	mm	KP-B		KP-BS		KP-B		KP-BS		in.	mm	
KP16B	KP16BS	1.0000	25.400	0.9995	25.387	0.0005	0.013	1.7500	44.450	1.9375	49.212	1.7510	44.475	1.9385	49.238	0.0010	0.025
		0.9995	25.387	0.9990	25.375			1.7490	44.425	1.9365	49.187	1.7500	44.450	1.9375	49.213		
KP21B	KP21BS	1.3130	33.350	1.3120	33.325	0.0010	0.025	2.0625	52.388	2.2500	57.150	2.0635	52.413	2.2510	57.175	0.0010	0.025
		1.3120	33.325	1.3110	33.299			2.0615	52.362	2.2490	57.125	2.0625	52.388	2.2500	57.150		
KP23B	KP23BS	1.4380	36.525	1.4370	36.500	0.0010	0.025	2.1875	55.562	2.3750	60.325	2.1885	55.588	2.3760	60.350	0.0010	0.025
		1.4370	36.500	1.4360	36.474			2.1865	55.537	2.3740	60.300	2.1875	55.562	2.3750	60.325		
KP25B	KP25BS	1.5630	39.700	1.5620	39.675	0.0010	0.025	2.3125	58.738	2.5000	63.500	2.3135	58.763	2.5010	63.525	0.0010	0.025
		1.5620	39.675	1.5610	39.649			2.3115	58.712	2.4990	63.475	2.3125	58.738	2.5000	63.500		
KP29B	KP29BS	1.8130	46.050	1.8120	46.025	0.0010	0.025	2.5625	65.088	2.7500	69.850	2.5635	65.113	2.7510	69.875	0.0010	0.025
		1.8120	46.025	1.8110	45.999			2.5615	65.062	2.7490	69.825	2.5625	65.088	2.7500	69.850		
KP33B	KP33BS	2.0630	52.400	2.0620	52.375	0.0010	0.025	2.8125	71.438	3.0000	76.200	2.8135	71.463	3.0010	76.225	0.0010	0.025
		2.0620	52.375	2.0610	52.349			2.8115	71.412	2.9990	76.175	2.8125	71.438	3.0000	76.200		
KP37B	KP37BS	2.3130	58.750	2.3120	58.725	0.0010	0.025	3.0625	77.788	3.2500	82.550	3.0635	77.813	3.2510	82.575	0.0010	0.025
		2.3120	58.725	2.3110	58.699			3.0615	77.762	3.2490	82.525	3.0625	77.788	3.2500	82.550		
KP47B	KP47BS	2.9380	74.625	2.9370	74.600	0.0010	0.025	3.8750	98.425	4.1250	104.775	3.8760	98.450	4.1260	104.800	0.0010	0.025
		2.9370	74.600	2.9360	74.574			3.8740	98.400	4.1240	104.750	3.8750	98.425	4.1250	104.775		
—	KP48BS	3.0000	76.200	2.9990	76.175	0.0010	0.025	—	—	4.2500	107.950	—	—	4.2510	107.975	0.0010	0.025
		2.9990	76.175	2.9980	76.149			—	—	4.2490	107.925	—	—	4.2500	107.950		
KP49B	KP49BS	3.0630	77.800	3.0620	77.775	0.0010	0.025	4.0000	101.600	4.2500	107.950	4.0010	101.625	4.2510	107.975	0.0010	0.025
		3.0620	77.775	3.0610	77.749			3.9990	101.575	4.2490	107.925	4.0000	101.600	4.2500	107.950		
KP52B	—	3.2500	82.550	3.2490	82.525	0.0010	0.025	4.1875	106.363	—	—	4.1885	106.388	—	—	0.0010	0.025
		3.2490	82.525	3.2480	82.499			4.1865	106.337	—	—	4.1875	106.363	—	—		
KP56B	—	3.5000	88.900	3.4990	88.875	0.0010	0.025	4.4375	112.713	—	—	4.4385	112.738	—	—	0.0010	0.025
		3.4990	88.875	3.4980	88.849			4.4365	112.687	—	—	4.4375	112.713	—	—		
KP60B	—	3.7500	95.250	3.7490	92.225	0.0010	0.025	4.6875	119.063	—	—	4.6885	119.088	—	—	0.0010	0.025
		3.7490	95.225	3.7480	95.199			4.6865	119.037	—	—	4.6875	119.063	—	—		

* For precision (M) series, KP-B and KP-BS, 16-49, use the same shaft outside diameter and housing bore diameter.

AIRFRAME CONTROL & BALL BEARING ROD ENDS

SHAFT AND HOUSING FITS FOR OSCILLATORY SERVICE (M)*B500 AND (M)*B500DD SERIES

Bearing Number	Shaft Fits						Housing Fits					
	Bearing Bore		Steel, Aluminum or Magnesium Shaft		Mean Fit Loose		Bearing O.D.		Steel, Aluminum or Magnesium Housing		Mean Fit Loose	
	in.	mm	in.	mm	in.	mm	in.	mm	in.	mm	in.	mm
B538, B538DD	0.6257	15.893	0.6243	15.857	0.0012	0.030	1.0625	26.988	1.0635	27.013	0.0010	0.025
	0.6243	15.857	0.6233	15.832			1.0615	26.962	1.0625	26.988		
B539, B539DD	0.7507	19.068	0.7493	19.032	0.0012	0.030	1.1875	30.162	1.1885	30.187	0.0010	0.025
	0.7493	19.032	0.7483	19.007			1.1865	30.137	1.1875	30.162		
B540, B540DD	0.8757	20.243	0.8743	22.207	0.0012	0.030	1.3125	33.338	1.3135	33.363	0.0010	0.025
	0.8743	22.207	0.8733	22.182			1.3115	33.313	1.3125	33.338		
B541, B541DD	1.0632	27.005	1.0618	26.970	0.0012	0.030	1.5000	38.100	1.5010	38.125	0.0010	0.025
	1.0618	26.970	1.0608	26.944			1.4990	38.075	1.5000	38.100		
B542, B542DD	1.3132	33.355	1.3118	33.320	0.0012	0.030	1.7500	44.450	1.7510	44.475	0.0010	0.025
	1.3118	33.320	1.3108	33.294			1.7490	44.425	1.7500	44.450		
B543, B543DD	1.5632	39.705	1.5618	39.670	0.0012	0.030	2.0000	50.800	2.0010	50.825	0.0010	0.025
	1.5618	39.670	1.5608	39.644			1.9990	50.775	2.0000	50.800		
B544, B544DD	1.8135	46.063	1.8115	46.012	0.0015	0.038	2.2500	57.150	2.2510	57.175	0.0012	0.030
	1.8115	46.012	1.8105	45.987			2.2485	57.112	2.2500	57.150		
B545, B545DD	2.0635	52.413	2.0615	52.362	0.0015	0.038	2.6250	66.675	2.6260	66.700	0.0012	0.030
	2.0615	52.362	2.0605	52.337			2.6235	66.637	2.6250	66.675		
B546, B546DD	2.3135	58.763	2.3115	58.712	0.0015	0.038	2.8750	73.025	2.8760	73.050	0.0012	0.030
	2.3115	58.712	2.3105	58.687			2.8735	72.987	2.8750	73.025		

* For precision (M) series, B500 and B500DD, 538-546, use the same shaft outside diameter and housing bore diameter.

SHAFT AND HOUSING FITS FOR OSCILLATORY SERVICE B500WZZ SERIES

Bearing Number	Shaft Fits						Housing Fits					
	Bearing Bore		Steel, Aluminum or Magnesium Shaft		Mean Fit Loose		Bearing O.D.		Steel, Aluminum or Magnesium Housing		Mean Fit Loose	
	in.	mm	in.	mm	in.	mm	in.	mm	in.	mm	in.	mm
B5538WZZ	0.6250	15.875	0.6245	15.862	0.0005	0.013	1.0625	26.988	1.0625	26.988	LINE	
	0.6245	15.862	0.6240	15.849			1.0620	26.975	1.0620	26.975		
B5539WZZ	0.7500	19.050	0.7495	19.037	0.0005	0.013	1.1875	30.162	1.1875	30.163	—	
	0.7495	19.037	0.7490	19.024			1.1870	30.150	1.1870	30.150		
B5540WZZ	0.8750	22.225	0.8745	22.212	0.0005	0.013	1.3125	33.338	1.3125	33.338	—	
	0.8745	22.212	0.8740	22.199			1.3120	33.325	1.3120	33.325		
B5541WZZ	1.0625	26.988	1.0620	26.975	0.0005	0.013	1.5000	38.100	1.5000	38.100	—	
	1.0620	26.975	1.0615	26.962			1.4995	38.087	1.4995	38.087		
B5542WZZ	1.3125	33.338	1.3120	33.325	0.0005	0.013	1.7500	44.450	1.7500	44.450	—	
	1.3120	33.325	1.3115	33.312			1.7495	44.437	1.7495	44.437		
B5543WZZ	1.5625	39.688	1.5620	39.675	0.0005	0.013	2.0000	50.800	2.0000	50.800	LINE	
	1.5620	39.675	1.5615	39.662			1.9995	50.787	1.9995	50.787		
B5544WZZ	1.8125	46.038	1.8117	46.018	0.0007	0.016	2.2500	57.150	2.2500	57.150	0.0001	0.003
	1.8117	46.018	1.8112	46.005			2.2493	57.132	2.2495	57.137		
B5545WZZ	2.0625	52.388	2.0617	52.368	0.0007	0.016	2.6250	66.675	2.6250	66.675	0.0001	0.003
	2.0617	52.368	2.0612	52.355			2.6243	66.657	2.6245	66.662		
B5546WZZ	2.3125	58.738	2.3117	58.718	0.0007	0.016	2.8750	73.025	2.8750	73.025	0.0001	0.003
	2.3117	58.718	2.3112	58.705			2.8743	73.007	2.8745	73.012		

Shaft diameter = Same dimensions as bearing bore.

Maximum housing bore = Maximum bearing O.D. plus the O.D. tolerance.

Minimum housing bore = Maximum bearing O.D.

The ideal fit for these series is "line-to-line". Therefore, wherever possible, selective assembly should be used.

SHAFT AND HOUSING FITS FOR OSCILLATORY SERVICE HGS SERIES

Bearing Description	Bearing O.D.		Housing						Shaft	
			Housing Bore		Mean Fit Slip		Roundness		Recommended Shaft fit from Nominal Bearing Bore	
	in.	mm	in.	mm	in.	mm	in.	mm	in.	mm
AAHGS0416	1.0000	25.400	1.0010	25.425	+ 0.001	+ 0.025	0.0004	0.01	-0.0005	-0.013
	.9995	25.387	1.0005	25.413						
AAHGS0520	1.2500	31.750	1.2510	31.775	+ 0.001	+ 0.025	0.0004	0.01	-0.0005	-0.013
	1.2495	31.737	1.2505	31.763						
AAHGS0520 A1*	1.2500	31.750	1.2510	31.775	+ 0.001	+ 0.025	0.0004	0.01	-0.0005	-0.013
	1.2495	31.737	1.2505	31.763						
AAHGS0623	1.4375	36.513	1.4385	36.538	+ 0.001	+ 0.025	0.0004	0.01	-0.0005	-0.013
	1.4370	36.500	1.4380	36.525						
AAHGS0624	1.5000	38.100	1.5010	38.125	+ 0.001	+ 0.025	0.0004	0.01	-0.0005	-0.013
	1.4995	38.087	1.5005	38.113						
AAHGS0725	1.5625	39.688	1.5635	37.713	+ 0.001	+ 0.025	0.0004	0.01	-0.0005	-0.013
	1.5620	39.675	1.5630	39.700						
AAHGS0828	1.7500	44.450	1.7510	44.475	+ 0.001	+ 0.025	0.0004	0.01	-0.0005	-0.013
	1.7495	44.437	1.7505	44.463						
AAHGS0828 A1*	1.7500	44.450	1.7510	44.475	+ 0.001	+ 0.025	0.0004	0.01	-0.0005	-0.013
	1.7495	44.437	1.7505	44.463						
AAHGS1031	1.9375	49.213	1.9385	49.238	+ 0.001	+ 0.025	0.0004	0.01	-0.0005	-0.013
	1.9370	49.200	1.9380	49.225						
AAHGS1031 A1*	1.9375	49.213	1.9385	49.238	+ 0.001	+ 0.025	0.0004	0.01	-0.0005	-0.013
	1.9370	49.200	1.9380	49.225						
AAHGS1231	1.9375	49.213	1.9385	49.238	+ 0.001	+ 0.025	0.0004	0.01	-0.0005	-0.013
	1.9370	49.200	1.9380	49.225						
AAHGS1242	2.6250	66.675	2.6262	66.705	+ 0.0012	+ 0.03	0.0005	0.013	-0.0005	-0.013
	2.6243	66.657	2.6257	66.693						
AAHGS1448	3.0000	76.200	3.0012	76.230	+ 0.0012	+ 0.03	0.0005	0.013	-0.0005	-0.018
	2.9993	76.182	3.0007	76.218						
AAHGS1640	2.5000	63.500	2.5012	63.530	+ 0.0012	+ 0.03	0.0005	0.013	-0.0005	-0.018
	2.4993	63.482	2.5007	63.518						
AAHGS1842	2.6250	66.675	2.6262	66.705	+ 0.0012	+ 0.03	0.0005	0.013	-0.0005	-0.018
	2.6243	66.657	2.6257	66.693						

*A1=Dimensional difference from nominal design.

AIRFRAME CONTROL & BALL BEARING ROD ENDS

HOUSING SHOULDER DIAMETERS

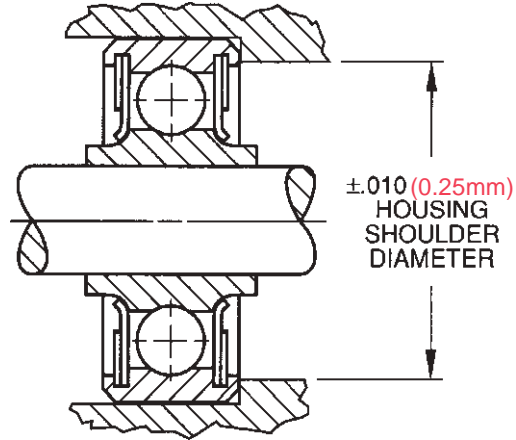

AIRFRAME CONTROL & BALL BEARING ROD ENDS

Bearing Number	Housing Shoulder Diameter	
	in.	mm
KP3L	0.564	14.30
KP3	0.622	15.80
KP4	0.732	18.60
KP5	1.014	25.80
KP6	1.234	31.30
KP8	1.454	36.90
KP10	1.646	41.80
KP3A	0.520	13.20
KP4A	0.620	15.70
KP5A	0.684	17.40
KP6A	0.754	19.20
KP8A	0.976	24.80
KP10A	1.214	30.80
KP12A	1.464	37.20
KP16A	1.764	44.80
KP20A	2.026	51.50
KSP3L	0.564	14.30
KSP4A	0.661	16.80
KSP5A	0.717	18.20
KSP6A	0.786	20.00
KSP3	0.656	16.70
KSP4	0.798	20.30
KSP5	1.058	26.90
KSP6	1.202	30.50
KSP8	1.532	38.90
KSP10	1.608	40.80

Bearing Number	Housing Shoulder Diameter	
	in.	mm
KP16B	1.593	40.50
KP21B	1.894	48.10
KP23B	2.016	51.20
KP25B	2.132	54.20
KP29B	2.372	60.20
KP33B	2.672	67.90
KP37B	2.910	73.90
KP47B	3.600	91.40
KP49B	3.768	95.70
KP52B	3.928	99.80
KP56B	4.188	106.40
KP60B	4.448	113.00
KP21BS	2.028	51.50
KP23BS	2.155	54.70
KP25BS	2.282	58.00
KP29BS	2.535	64.40
KP33BS	2.787	70.80
KP37BS	3.039	77.20
KP47BS	3.846	97.70
KP48BS	3.972	100.90
KP49BS	3.972	100.90

Bearing Number	Housing Shoulder Diameter	
	in.	mm
DPP3	0.634	16.10
DPP3W	0.634	16.10
DPP4	0.718	18.20
DPP4W	0.718	18.20
DPP5	1.078	27.40
DPP5W	1.078	27.40
DPP6	1.248	31.70
DPP6W	1.248	31.70
DPP	1.468	37.30
DPP8W	1.468	37.30
DPP10	1.638	41.60
DPP10W	1.638	41.60
DSP3	0.610	15.50
DSP4	0.714	18.10
DSP5	0.974	24.70
DSP6	1.168	29.70
DSP8	1.400	35.60
DSP10	1.638	41.60
DSRP4	0.714	18.10
DSRP5	0.974	24.70
DSRP6	1.168	29.70
DSRP8	1.400	35.60
DSRP10	1.638	41.60
DSRP12	1.850	47.00

Bearing Number	Housing Shoulder Diameter	
	in.	mm
B538	0.924	23.50
B539	1.042	26.50
B540	1.162	29.50
B541	1.360	34.50
B542	1.598	40.60
B543	1.838	46.70
B544	2.116	53.70
B545	2.434	61.80
B546	2.678	68.00
DW4K2	0.530	13.50
DW4K	0.644	16.40
DW4	0.644	16.40
DW5	0.758	19.30
DW6	0.938	23.80
DW8	1.232	31.30
BCP4W10	0.634	16.10
BCP5W11	0.758	19.30
P4K	0.728	18.50
P5K	0.724	18.40
PD5K	0.768	19.50
P8(FT)	1.454	36.90
P10K	1.022	26.00

AIRFRAME CONTROL & BALL BEARING ROD ENDS

COMPARISON OF INSPECTION LIMITS - STANDARD SERIES VERSUS PRECISION SERIES

Bearing Series	Standard KP, KP-A, KSP ⁽¹⁾ , KSP-A ⁽¹⁾ , DPP, DSP, DW, DSRP, GDSRP		Precision MKP, MKP-A, MKSP, MKSP-A, MDPP, MDSP, MDW, MDSRP		Standard KP-B and KP-BS		Precision MKP-B and MKP-BS		Standard B538(DD) thru B543(DD)		Precision MB538(DD) thru MB543(DD)		Standard B544(DD) and up		Precision MB544(DD) and up		
	in.	mm	in.	mm	in.	mm	in.	mm	in.	mm	in.	mm	in.	mm	in.	mm	
bore:	mean diameter	+0.0000	+0.000	+0.0000	+0.000	+0.0000	+0.000	+0.0000	+0.000	+0.0007	+0.018	+0.0000	+0.000	+0.0010	+0.025	+0.0000	+0.000
		-0.0005	-0.013	-0.0003	-0.008	-0.0010	-0.025	-0.0005	-0.013	-0.0007	-0.018	-0.0005	-0.013	-0.0010	-0.025	-0.0008	-0.020
O.D.:	mean diameter	+0.0000	+0.000	+0.0000	+0.000	+0.0000	+0.000	+0.0000	+0.000	+0.0000	+0.000	+0.0000	+0.000	+0.0000	+0.000	+0.0000	+0.000
		-0.0005	-0.013	-0.0004	-0.010	-0.0010	-0.025	-0.0010	-0.025	-0.0010	-0.025	-0.0005	-0.013	-0.0015	-0.038	-0.0007	-0.018
width:	inner	+0.0000	+0.000	+0.0000	+0.000	+0.0000	+0.000	+0.0000	+0.000	+0.0000	+0.000	+0.0000	+0.000	+0.0000	+0.000	+0.0000	+0.000
		-0.0050	-0.130	-0.0025	-0.064	-0.0050	-0.130	-0.0025	-0.064	-0.0050	-0.130	-0.0025	-0.064	-0.0050	-0.130	-0.0025	-0.064
width:	outer	+0.0000	+0.000	+0.0000	+0.000	+0.0000	+0.000	+0.0000	+0.000	+0.0000	+0.000	+0.0000	+0.000	+0.0000	+0.000	+0.0000	+0.000
		-0.0050	-0.130	-0.0050	-0.130	-0.0050	-0.130	-0.0050	-0.130	-0.0050	-0.130	-0.0050	-0.130	-0.0050	-0.130	-0.0050	-0.130
parallelism:	inner	0.0008	0.020	0.0005	0.013	0.0008	0.020	0.0004	0.010	0.0008	0.020	0.0004	0.010	0.0008	0.020	0.0004	0.010
	outer	0.0008	0.020	0.0005	0.013	0.0008	0.020	0.0004	0.010	0.0008	0.020	0.0004	0.010	0.0008	0.020	0.0004	0.010
squareness:	inner	0.0010	0.025	0.0005	0.013	0.0010	0.025	0.0005	0.013	0.0010	0.025	0.0005	0.013	0.0010	0.025	0.0005	0.013
	outer	0.0010	0.025	0.0005	0.013	0.0010	0.025	0.0005	0.013	0.0010	0.025	0.0005	0.013	0.0010	0.025	0.0005	0.013
radial eccentricity:	inner	0.0010	0.025	0.0005	0.013	0.0010	0.025	0.0008	0.020	0.0020	0.050	0.0008	0.020	0.0020	0.050	0.0008	0.020
	outer	0.0016	0.040	0.0008	0.020	0.0016	0.040	0.0008	0.020	0.0016	0.040	0.0008	0.020	0.0016	0.040	0.0008	0.020
face runout:	inner	0.0010	0.025	0.0007	0.018	0.0010	0.025	0.0008	0.020	0.0020	0.050	0.0008	0.020	0.0020	0.050	0.0008	0.020
	outer	0.0016	0.040	0.0010	0.025	0.0016	0.040	0.0010	0.025	0.0016	0.040	0.0008	0.020	0.0016	0.040	0.0008	0.020

(1) Radial play for KSP and KSP-A series is .000 in. / .0010 in.

(2) Not applicable to self-aligning bearings.

Note: These tolerances conform to those shown in ANSIBAMA standard 16.2

INTERNAL CLEARANCES

Bearing Sizes		Radial Play ⁽²⁾			
Standard	Precision M Series	in.		mm	
KP, KP-A ⁽¹⁾		0.0004	0.0010	0.010	0.025
	MKP, MKP-A	0.0002	0.0005	0.005	0.013
KSP, KSP-A		0.0000	0.0010	0.000	0.025
	MKSP, MKSP-A	0.0001	0.0005	0.003	0.013
	MKP-B(S)	0.0001	0.0005	0.003	0.013
DSRP, GDSRP	MDSRP	0.0004	0.0008	0.010	0.020
KP16B(S)-KP49B(S)		0.0003	0.0010	0.008	0.025
KP52B(S) and up		0.0003	0.0015	0.008	0.038
B538(DD)-B546(DD)		0.0008	0.0018	0.020	0.046
	MB538(DD)- MB546(DD)	0.0001	0.0005	0.003	0.013
DW, DPP ⁽¹⁾		0.0010	0.0030	0.025	0.076
DSP ⁽¹⁾	MDSRP	0.0035	0.0055	0.089	0.140
	MDW, MDPP	0.0010	0.0020	0.025	0.051

⁽¹⁾ For reduced radial play of .0002 in.\.0005 in., .005mm\0.013mm.

⁽²⁾ Under 5.5 lb. (2.49kg) gage load.

INTERNAL CLEARANCES HGS SERIES

Bearing Description	Internal Clearance			
	Axial		Radial	
	in.	mm	in.	mm
AAHGS0416	.0005 -.0054	.013 -.137	.0002-.0010	.005-.025
AAHGS0520	.0005 -.0052	.013 -.132	.0002-.0010	.005-.025
AAHGS0520 A1	.0005 -.0052	.013 -.132	.0002-.0010	.005-.025
AAHGS0623	.0005 -.0052	.013 -.132	.0002-.0010	.005-.025
AAHGS0624	.0005 -.0052	.013 -.132	.0002-.0010	.005-.025
AAHGS0725	.0005 -.0052	.013 -.132	.0002-.0010	.005-.025
AAHGS0828	.0006 -.0060	.015 -.152	.0002-.0010	.005-.025
AAHGS0828 A1	.0006 -.0030	.015 -.076	.0002-.0010	.005-.025
AAHGS1031	.0006 -.0058	.015 -.147	.0002-.0010	.005-.025
AAHGS1031 A1	.0006 -.0030	.015 -.176	.0002-.0010	.005-.025
AAHGS1231	.0012 -.0058	.030-.147	.0004-.0010	.010-.025
AAHGS1242	.0024 MAX	.061 MAX	.0004 MAX	.010 MAX
AAHGS1448	.0024 MAX	.061 MAX	.0004 MAX	.010 MAX
AAHGS1640	.0026 MAX	.066 MAX	.0004 MAX	.010 MAX
AAHGS1842	.0030 MAX	.076 MAX	.0004 MAX	.010 MAX

RBC Airframe Control Ball Bearings

PRODUCT NOMENCLATURE 27

SINGLE ROW BALL BEARINGS

Standard Series

MS27640 KP Series: Radial, Heavy Duty 28

MS27641 KP-A Series: Deep Groove, Medium Duty 29

MS27649 AW-AK Series: Deep Groove, CRES, Not Plated 30

MS27645 KSP, KSP-A Series: Self-aligning, Light and Heavy Duty 31

MS27642 KP-B Series: Torque Tube, Light Duty 32

MS27648 KP-BS Series: External Self-aligning, Extra Light 33

B500 Series: Extra Light Torque Tube, Not Plated, No Seals 34

MS27646 B500DD Series: Extra Light Torque Tube, Reinforced Teflon® Shields 35

K Series: 36

MS21443 P Series: Heavy Duty 37

MS21443 Pulley Series: For MIL-P-7034 Pulleys 38

Precision Series

MS27640-R MKP Series: Radial, Heavy Duty, Precision 39

MS27641-R MKP-A Series: Deep Groove, Medium Duty, Precision 40

MS27645-R MKSP, MKSP-A Series: Self-aligning Light and Heavy Duty, Precision 41

MS27642-S MKP-B Series: Torque Tube, Light Duty, Precision 42

MKP-BS Series: External Self-aligning, Extra Light, Precision 43

MB500 Series: Extra Light Torque Tube, Not Plated, No Seals, Precision 44

MS21428 MB500DD Series: Extra Light Torque Tube, Reinforced Teflon® Shields, Precision 45

DOUBLE ROW BALL BEARINGS

Standard Series

MS27644 DPP,DPP-W Series: Light and Heavy Series 46

MS27643 DSP Series: Self-aligning, Heavy Duty 47

MS27647 DW,GDW Series: Extra Wide, Medium Duty 48

B5500WZZ Series: Extra Light Duty 49

D Series 50

G, BCP Series 51

Precision Series

MDPP Series: Light and Heavy Duty, Precision 52

MS27643-R MDSP Series: Self-aligning, Heavy Duty, Precision 53

MS27647-R MDW Series: Medium Duty, Precision 54

AIRFRAME CONTROL BALL BEARINGS

GENERAL FEATURES AND TECHNICAL SPECIFICATIONS

Inner and Outer Rings

Rings are made from thru-hardened 52100 or CRES 440C to accommodate the application's need. The external ring surfaces are plated with cadmium or zinc nickel to provide protection from galvanic corrosion.

Seals and Retaining Caps

These bearings are equipped with PTFE seals and held in place by corrosion resistance retaining caps.

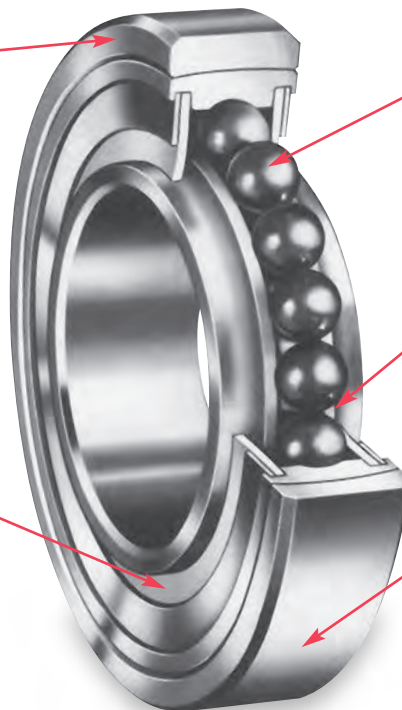

Load Capabilities

Airframe Ball bearings are designed with a full complement of balls to maximize load carrying capacity.

Lubrication

Bearings are 80 to 100% filled with greases in compliance with MIL-PRF-81322 and MIL-PRF-23827.

Construction

Available in single and double row construction to accommodate different load requirements. Self-aligning constructions are also available to accommodate misalignment needs.

© 2008, 2011, 2018 RBC Bearings Incorporated. All rights reserved.

AIRFRAME CONTROL BALL BEARINGS

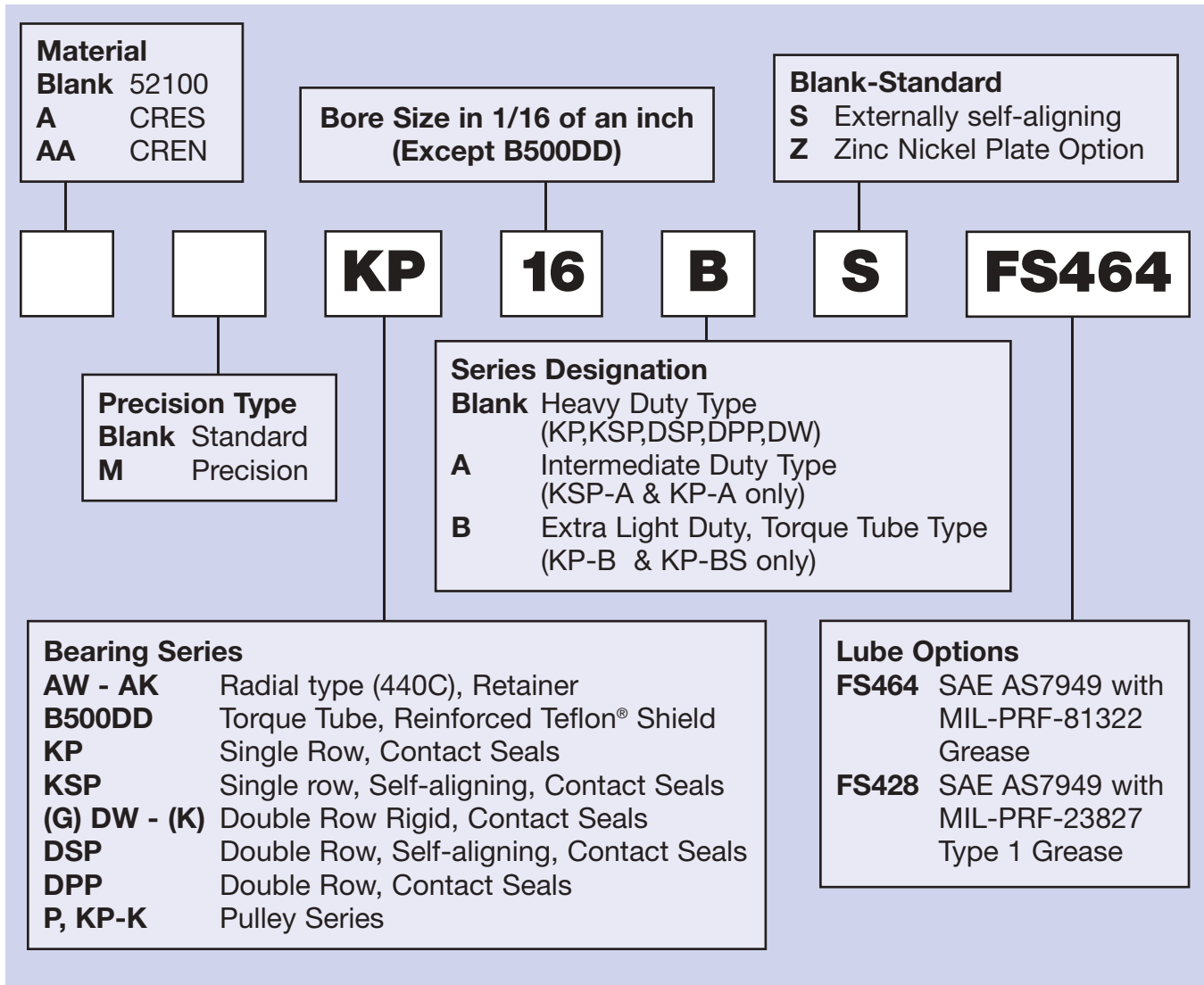

AIRFRAME CONTROL BALL BEARINGS

MS27640 • SAE-AS7949

- Single row, ball, heavy duty
- PTFE seals and CRES sealcaps
- Exposed surfaces except bore, caps, and seals are cadmium plated
- Prelubricated for life
- Also offered with CRES 440C material and/or zinc nickel plating per OEM specifications

AIRFRAME CONTROL BALL BEARINGS

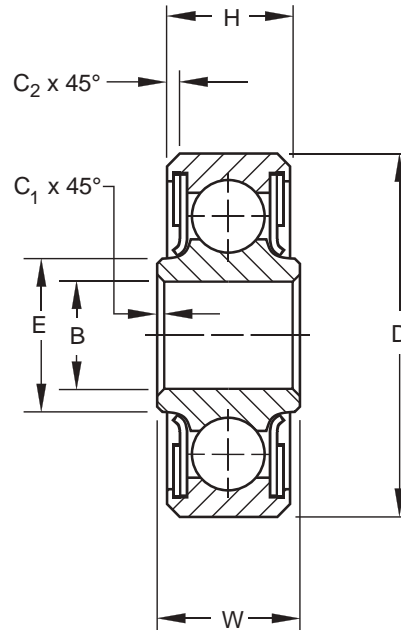

SPECIFICATIONS AND ORDERING INFORMATION

TO ORDER, SPECIFY BEARING NUMBER AND FACTORY SPECIFICATION. SEE TABLE 1 ON PG 8. (Example KP3L FS464)

Bearing Number	MS 27640 Dash No.	Bore B		Outside Diameter D		Widths				E	C ₁		C ₂		Wt.		Radial Limit Load Rating	Thrust Limit Load Rating			
						W		H							Approx.						
		in.	mm	in.	mm	in.	mm	in.	mm		in.	mm	in.	mm	in.	mm			lbs.	kg	
KP3L ⁽¹⁾	-3A	0.1900	4.826	0.6250	15.875	0.245	6.22	0.203	5.16	0.285	7.24	0.005	0.13	0.010	0.25	0.01	0.005	1560	6950	700	3100
KP3	-3	0.1900	4.826	0.7774	19.746	0.297	7.54	0.270	6.86	0.336	8.53	0.005	0.13	0.022	0.56	0.03	0.014	1880	8400	900	4000
KP4	-4	0.2500	6.350	0.9014	22.896	0.484	12.29	0.335	8.51	0.395	10.03	0.005	0.13	0.032	0.81	0.04	0.018	2680	12000	1200	5300
KP5	-5	0.3125	7.938	1.2500	31.750	0.558	14.17	0.375	9.53	0.474	12.04	0.015	0.38	0.032	0.81	0.09	0.041	5620	25000	2500	11200
KP6	-6	0.3750	9.525	1.4375	36.513	0.620	15.75	0.469	11.91	0.596	15.14	0.015	0.38	0.032	0.81	0.15	0.068	7910	35500	3500	15600
KP8	-8	0.5000	12.700	1.6875	42.863	0.620	15.75	0.500	12.70	0.773	19.63	0.015	0.38	0.044	1.12	0.21	0.095	11800	52500	5200	23200
KP10	-10	0.6250	15.875	1.9375	49.213	0.620	15.75	0.500	12.70	0.855	21.72	0.015	0.38	0.044	1.12	0.28	0.127	14100	62800	6200	27600

⁽¹⁾ Bonded PTFE Seals.

MS27641 • SAE-AS7949

- Single row, ball, deep groove, medium duty
- PTFE seals and CRES sealcaps
- Exposed surfaces except bore, caps, and seals are cadmium plated
- Prelubricated for life
- Also offered with CRES 440C material and/or zinc nickel plating per OEM specifications

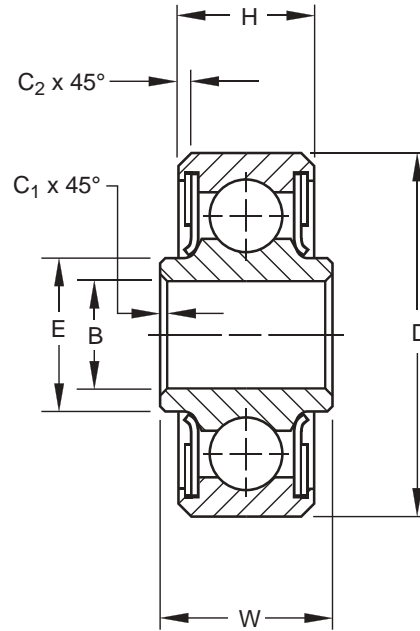

AIRFRAME CONTROL BALL BEARINGS

SPECIFICATIONS AND ORDERING INFORMATION

TO ORDER, SPECIFY BEARING NUMBER AND FACTORY SPECIFICATION. SEE TABLE 1 ON PG 8. (Example KP3AL FS464)

Bearing Number	MS 27641 Dash No.	Bore B		Outside Diameter D		Widths				E	C ₁		C ₂		Wt.		Radial Limit Load Rating	Thrust Limit Load Rating			
						W		H							Approx.						
		in.	mm	in.	mm	in.	mm	in.	mm	in.	mm	in.	mm	in.	mm	lbs.	kg	lbf.	N	lbf.	N
KP3AL ⁽¹⁾	-	0.1900	4.826	0.5000	12.700	0.237	6.02	0.196	4.98	0.261	6.63	0.005	0.13	0.012	0.30	0.01	0.005	970	4350	430	1950
KP3A	-3	0.1900	4.826	0.6250	15.875	0.297	7.54	0.234	5.94	0.302	7.67	0.005	0.13	0.016	0.41	0.01	0.005	1560	6950	700	3150
KP4A	-4	0.2500	6.350	0.7500	19.050	0.281	7.14	0.219	5.56	0.385	9.78	0.005	0.13	0.016	0.41	0.02	0.009	1880	8400	900	4000
KP5A	-5	0.3125	7.938	0.8125	20.638	0.297	7.54	0.234	5.94	0.433	11.00	0.015	0.38	0.016	0.41	0.02	0.009	2190	9800	1000	4500
KP6A	-6	0.3750	9.525	0.8750	22.225	0.313	7.95	0.250	6.35	0.512	13.00	0.015	0.38	0.016	0.41	0.03	0.014	2500	11200	1100	4900
KP8A	-8	0.5000	12.700	1.1250	28.575	0.375	9.53	0.313	7.95	0.638	16.21	0.015	0.38	0.016	0.41	0.05	0.023	3910	17400	1700	7600
KP10A	-10	0.6250	15.875	1.3750	34.925	0.406	10.31	0.344	8.74	0.773	19.63	0.015	0.38	0.032	0.81	0.08	0.036	6700	30000	3000	13400
KP12A	-12	0.7500	19.050	1.6250	41.275	0.437	11.10	0.375	9.53	0.967	24.56	0.015	0.38	0.032	0.81	0.13	0.059	8790	39100	3900	17400
KP16A	-16	1.0000	25.400	2.0000	50.800	0.500	12.70	0.438	11.13	1.268	32.21	0.015	0.38	0.032	0.81	0.22	0.100	11900	53000	5200	23200
KP20A	-20	1.2500	31.750	2.2500	57.150	0.500	12.70	0.438	11.13	1.503	38.18	0.015	0.38	0.032	0.81	0.26	0.118	13800	61400	6100	27200

⁽¹⁾ KP3AL not MS27641.

AIRFRAME CONTROL BALL BEARINGS — AW-AK SERIES RADIAL, STAINLESS STEEL



MS27649 • SAE-AS7949

- Single row, ball, deep groove
- Rings and balls are made of CRES 440C (not cadmium plated)
- PTFE seals and CRES sealcaps
- Prelubricated for life
- Bores and outside diameters of this series are the same as for corresponding sizes of the KP-A Series on page 28, but rings are wider for retainers and seals, and offsets between inner and outer ring faces are greater, providing increased bracket clearance at mounting

AIRFRAME CONTROL BALL BEARINGS

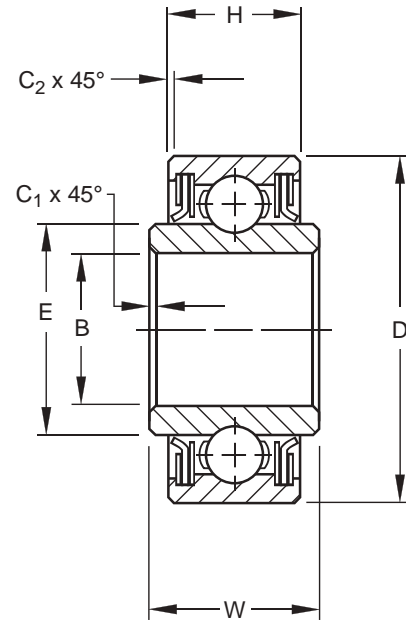

SPECIFICATIONS AND ORDERING INFORMATION

TO ORDER, SPECIFY BEARING NUMBER AND FACTORY SPECIFICATION. SEE TABLE 1 ON PG 8. (Example AW3AK FS464)

Bearing Number	MS 27649 Dash No.	Bore B		Outside Diameter D		Widths				E	C ₁		C ₂		Wt.		Radial Limit Load Rating	Thrust Limit Load Rating			
		+0.0000, -0.0005 +0.000, -0.013		+0.0000, -0.0005 +0.000, -0.013		+0.0000, -0.0025 +0.000, -0.064		+0.000, -0.005 +0.00, -0.13			Approx.		+0.015, -0.000 +0.38, -0.00		+0.015, -0.000 +0.38, -0.00				Approx.		
		in.	mm	in.	mm	in.	mm	in.	mm	in.	mm	in.	mm	in.	mm	lbs.	kg	lbf.	N	lbf.	N
*AW3AK	-3	0.1900	4.826	0.6250	15.875	0.4060	10.310	0.312	7.92	0.317	8.05	0.005	0.13	0.016	0.41	0.018	0.008	750	3350	350	1560
*AW4AK	-4	0.2500	6.350	0.7500	19.050	0.4380	11.130	0.312	7.92	0.415	10.54	0.005	0.13	0.016	0.41	0.028	0.013	880	3900	410	1830
*AW5AK	-5	0.3125	7.938	0.8125	20.638	0.4690	11.910	0.344	8.74	0.462	11.73	0.015	0.38	0.016	0.41	0.033	0.015	1370	6100	640	2850
*AW6AK	-6	0.3750	9.525	0.8750	22.225	0.4690	11.910	0.344	8.74	0.520	13.21	0.015	0.38	0.016	0.41	0.034	0.015	1370	6100	640	2850
*AW8AK	-8	0.5000	12.700	1.1250	28.575	0.5620	14.270	0.438	11.13	0.681	17.30	0.015	0.38	0.016	0.41	0.075	0.034	2250	10000	1050	4650
*AW10AK ⁽¹⁾	-10	0.6250	15.875	1.3750	34.925	0.5940	15.090	0.469	11.91	0.848	21.54	0.015	0.38	0.032	0.81	0.119	0.054	3060	13600	1430	6400
*AW12AK ⁽¹⁾	-12	0.7500	19.050	1.6250	41.275	0.6560	16.660	0.531	13.49	1.052	26.72	0.015	0.38	0.032	0.81	0.189	0.086	4000	17800	1870	8300
*AW16AK ⁽¹⁾	-16	1.0000	25.400	2.0000	50.800	0.6880	17.480	0.562	14.27	1.334	33.88	0.015	0.38	0.032	0.81	0.296	0.134	5000	22300	2340	10400
*AW20AK ⁽¹⁾	-20	1.2500	31.750	2.2500	57.150	0.6880	17.480	0.562	14.27	1.615	41.02	0.015	0.38	0.032	0.81	0.355	0.161	6000	26700	2800	12500

⁽¹⁾ Not in production. Will be produced as requirements justify tooling.

* Check for availability.

MS27645 • SAE-AS7949

- Single row, ball, self-aligning, light and heavy duty
- Bonded PTFE seals
- Exposed surfaces except bore, caps, and seals are cadmium plated
- Prelubricated for life
- Also offered with CRES 440C material and/or zinc nickel plating per OEM specifications

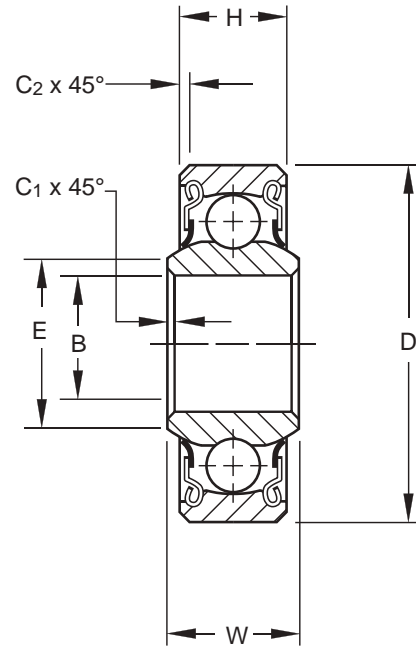

AIRFRAME CONTROL BALL BEARINGS

SPECIFICATIONS AND ORDERING INFORMATION

TO ORDER, SPECIFY BEARING NUMBER AND FACTORY SPECIFICATION. SEE TABLE 1 ON PG 8. (Example KSP3L FS464)

Bearing Number ⁽¹⁾	MS 27645 Dash No.	Bore B		Outside Diameter D		Widths				E		C ₁		C ₂		Wt.		Radial Limit Load Rating	Thrust Limit Load Rating		
		+0.0000, -0.0005 +0.000, -0.013		+0.0000, -0.0005 +0.000, -0.013		+0.0000, -0.005 +0.000, -0.13		+0.000, -0.005 +0.00, -0.13		Approx.		+0.015, -0.000 +0.38, -0.00		+0.015, -0.000 +0.38-0.00		Approx.					
		in.	mm	in.	mm	in.	mm	in.	mm	in.	mm	in.	mm	in.	mm	lbs.	kg			lb.	N
KSP3L	-3A	0.1900	4.826	0.6250	15.875	0.245	6.22	0.203	5.16	0.256	6.50	0.005	0.13	0.016	0.41	0.01	0.005	550	2450	100	450
KSP4A ⁽¹⁾	-4A	0.2500	6.350	0.7500	19.050	0.281	7.14	0.219	5.56	0.328	8.33	0.005	0.13	0.016	0.41	0.02	0.009	900	4000	200	900
KSP5A ⁽¹⁾	-5A	0.3125	7.938	0.8125	20.638	0.297	7.54	0.234	5.94	0.389	9.88	0.015	0.38	0.016	0.41	0.02	0.009	1000	4400	200	900
KSP6A ⁽¹⁾	-6A	0.3750	9.525	0.8750	22.225	0.313	7.95	0.250	6.35	0.462	11.73	0.016	0.41	0.016	0.41	0.03	0.014	1120	5000	200	900
KSP3	-3	0.1900	4.826	0.7774	19.746	0.297	7.54	0.270	6.86	0.297	7.54	0.005	0.13	0.022	0.56	0.03	0.014	900	4000	200	900
KSP4	-4	0.2500	6.350	0.9014	22.896	0.484	12.29	0.335	8.51	0.396	10.06	0.005	0.13	0.032	0.81	0.04	0.018	1410	6300	300	1340
KSP5	-5	0.3125	7.938	1.2500	31.750	0.558	14.17	0.375	9.52	0.567	14.40	0.015	0.38	0.032	0.81	0.10	0.045	2190	9800	300	1340
KSP6	-6	0.3750	9.525	1.4375	36.512	0.620	15.75	0.469	11.91	0.612	15.54	0.015	0.38	0.032	0.81	0.15	0.068	2980	13200	400	1780
KSP8	-8	0.5000	12.700	1.6875	42.862	0.620	15.75	0.500	12.70	0.796	20.22	0.015	0.38	0.044	1.12	0.23	0.104	3670	16300	500	2230
KSP10	-10	0.6250	15.875	1.9375	49.212	0.813	20.65	0.625	15.88	0.922	23.42	0.015	0.38	0.044	1.12	0.37	0.168	5320	23600	600	2670

⁽¹⁾ These bearings are self-aligning for 10° in either direction except KSP4A, KSP5A and KSP6A which are self-aligning for 8° in either direction.

MS27642 • SAE-AS7949

- Single row, ball, light duty
- PTFE seals and CRES sealcaps
- Exposed surfaces except bore, caps, and seals are cadmium plated
- Prelubricated for life
- Also offered with CRES 440C material and/or zinc nickel plating per OEM specifications

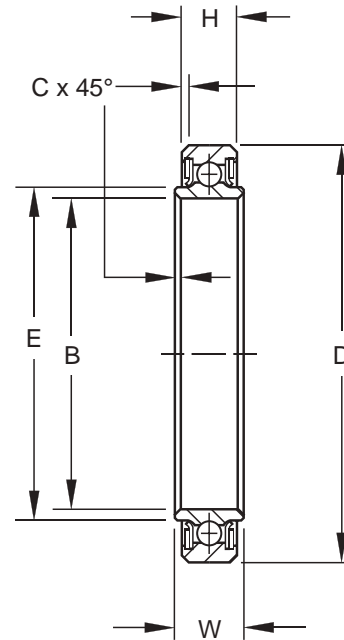

AIRFRAME CONTROL BALL BEARINGS

SPECIFICATIONS AND ORDERING INFORMATION

TO ORDER, SPECIFY BEARING NUMBER AND FACTORY SPECIFICATION. SEE TABLE 1 ON PG 8. (Example KP16B FS464)

Bearing Number	MS 27642 Dash No.	Bore B		Outside Diameter D		Widths		E	C	Wt.	Radial Limit Load Rating	Thrust Limit Load Rating							
						W	H												
				+0.0000, -0.0010 +0.000, -0.025	+0.0000, -0.0010 +0.000, -0.025	+0.0000, -0.005 +0.000, -0.13	+0.000, -0.005 +0.00, -0.13	Approx.	+0.015, -0.000 +0.38, -0.00	Approx.									
		in.	mm	in.	mm	in.	mm	in.	mm	lbs.	kg	lbf.	N	lbf.	N				
KP16B	-16	1.0000 ⁽¹⁾	25.400 ⁽¹⁾	1.7500	44.450	0.437	11.10	0.375	9.53	1.150	29.21	0.024	0.61	0.14	0.064	8085	36000	3600	16000
KP21B	-21	1.3130	33.350	2.0625	52.388	0.437	11.10	0.375	9.53	1.465	37.21	0.024	0.61	0.16	0.073	9840	43800	4400	19600
KP23B	-23	1.4380	36.525	2.1875	55.563	0.437	11.10	0.375	9.53	1.585	40.26	0.024	0.61	0.17	0.077	10500	46700	4700	20900
KP25B	-25	1.5630	39.700	2.3125	58.738	0.437	11.10	0.375	9.53	1.700	43.18	0.024	0.61	0.19	0.086	11300	50300	5000	22300
KP29B	-29	1.8130	46.050	2.5625	65.088	0.437	11.10	0.375	9.53	1.940	49.28	0.024	0.61	0.21	0.095	12700	56500	5600	25000
KP33B	-33	2.0630	52.400	2.8125	71.438	0.437	11.10	0.375	9.53	2.234	56.74	0.024	0.61	0.23	0.104	14400	64000	6400	28600
KP37B	-37	2.3130	58.750	3.0625	77.788	0.437	11.10	0.375	9.53	2.475	62.87	0.024	0.61	0.26	0.118	15800	70300	7000	31100
KP47B	-47	2.9380	74.625	3.8750	98.425	0.531	13.49	0.469	11.91	3.105	78.87	0.039	0.99	0.49	0.222	24700	110000	10900	48500
KP49B	-49	3.0630	77.800	4.0000	101.600	0.531	13.49	0.469	11.91	3.230	82.04	0.039	0.99	0.53	0.240	27500	122500	12100	54000
*KP52B	-52	3.2500	82.550	4.1875	106.363	0.531	13.49	0.469	11.91	3.460	87.88	0.039	0.99	0.55	0.249	28700	127700	12600	56000
*KP56B	-56	3.5000	88.900	4.4375	112.713	0.531	13.49	0.469	11.91	3.734	94.84	0.039	0.99	0.61	0.277	31200	140000	13700	61000
*KP60B	-60	3.7500	95.250	4.6875	119.063	0.531	13.49	0.469	11.91	3.972	100.89	0.039	0.99	0.64	0.290	33100	147300	14600	65000
*KP64B	-64	4.0000	101.600	4.9375	125.413	0.531	13.49	0.469	11.91	4.217	107.11	0.039	0.99	0.64	0.290	35500	157900	15400	68500
*KP68B	-68	4.2500	107.950	5.3125	134.938	0.593	15.06	0.531	13.49	4.478	113.74	0.039	0.99	0.73	0.331	41900	186400	18400	81800
*KP72B	-72	4.5000	114.300	5.5625	142.875	0.593	15.06	0.531	13.49	4.736	120.29	0.039	0.99	0.76	0.345	44300	197000	19500	86700

⁽¹⁾ +0.0000, -0.0005 in.; +0.000, -0.013mm.

*Check for availability.

MS27648 • SAE-AS7949

- Single row, ball, external self aligning, extra light duty
- PTFE seals and CRES sealcaps
- Exposed surfaces except bore, caps, and seals are cadmium plated
- Prelubricated for life
- Series is internally identical to the KP-B series. Self-alignment is provided by an external self-aligning ring whose internal spherically-ground surface is accurately matched to the external spherically-ground surface of the outer ring. These bearings are designed to compensate for initial misalignment
- Also offered with CRES 440C material and/or zinc nickel plating per OEM specifications

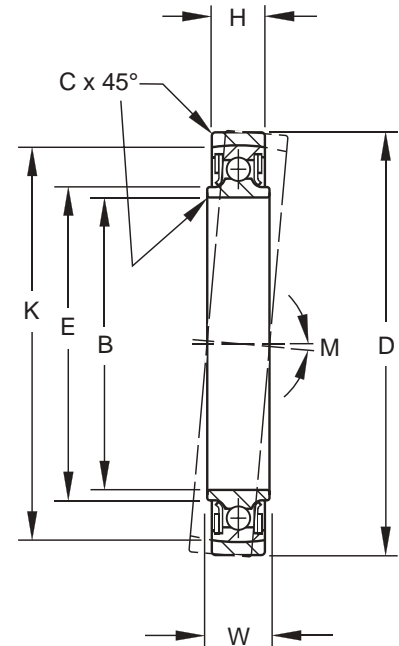

AIRFRAME CONTROL BALL BEARINGS

SPECIFICATIONS AND ORDERING INFORMATION

TO ORDER, SPECIFY BEARING NUMBER AND FACTORY SPECIFICATION. SEE TABLE 1 ON PG 8. (Example KP16BS FS464)

Bearing Number	MS 27648 Dash No.	Bore B		Outside Diameter D		Widths				E	C		K To Sharp Corner (Ref.)	M Mis-alignment Either Direction (Ref.)	Wt.		Radial Limit Load Rating	Thrust Limit Load Rating				
		+0.0000, -0.0010 +0.000, -0.025		+0.0000, -0.0010 +0.000, -0.025		+0.0000, -0.005 +0.000, -0.13		+0.000, -0.005 +0.00, -0.13			+0.015, -0.000 +0.38, -0.00				Approx.							
		in.	mm	in.	mm	in.	mm	in.	mm	in.	mm	in.	mm	in.	mm	lbs.	kg	lb.	N	lb.	N	
KP16BS	-16	1.0000 ⁽¹⁾	25.400 ⁽¹⁾	1.9375	49.213	0.437	11.10	0.375	9.53	1.150	29.21	0.024	0.61	1.709	43.41	7°25'	0.18	0.082	8085	36000	1600	7100
KP21BS	-21	1.3130	33.350	2.2500	57.150	0.437	11.10	0.375	9.53	1.465	37.21	0.024	0.61	2.028	51.51	6°30'	0.20	0.091	9840	43800	2000	9000
KP23BS	-23	1.4380	36.525	2.3750	60.325	0.437	11.10	0.375	9.53	1.585	40.26	0.024	0.61	2.155	54.74	6°	0.22	0.100	10500	46700	2200	9800
KP25BS	-25	1.5630	39.700	2.5000	63.500	0.437	11.10	0.375	9.53	1.700	43.18	0.024	0.61	2.282	57.96	5°45'	0.25	0.113	11300	50300	2300	10200
KP29BS	-29	1.8130	46.050	2.7500	69.850	0.437	11.10	0.375	9.53	1.940	49.28	0.024	0.61	2.535	64.39	5°	0.27	0.122	12700	56500	2600	11600
KP33BS	-33	2.0630	52.400	3.0000	76.200	0.437	11.10	0.375	9.53	2.234	56.74	0.024	0.61	2.787	70.79	5°	0.30	0.136	14400	64000	2900	12900
KP37BS	-37	2.3130	58.750	3.2500	82.550	0.437	11.10	0.375	9.53	2.475	62.87	0.024	0.61	3.039	77.19	4°30'	0.33	0.150	15800	70300	3200	14300
KP47BS	-47	2.9380	74.625	4.1250	104.775	0.531	13.49	0.469	11.91	3.105	78.87	0.039	0.99	3.846	97.69	4°30'	0.64	0.290	24700	110000	5000	22300
*KP48BS	-48	3.0000	76.200	4.2500	107.950	0.531	13.49	0.469	11.91	3.230	82.04	0.039	0.99	3.972	100.89	4°	0.69	0.313	27500	122000	5500	24500
KP49BS	-49	3.0625	77.788	4.2500	107.950	0.531	13.49	0.469	11.91	3.230	82.04	0.039	0.99	3.972	100.89	4°	0.69	0.313	27500	122000	5500	24500

⁽¹⁾ +0.0000 in. (.000mm), -0.0005 in. (.013mm).

* Check for availability.

B500 Series

- Extra light duty
- Single row, ball
- This series is made of bearing quality chromium-alloy, high carbon steel, and is not cadmium plated
- Open type — no seals or shields (unsealed version of B500DD)
- Packaged/shipped with preservative oil
- Also offered with CRES 440C material per OEM specifications

AIRFRAME CONTROL BALL BEARINGS

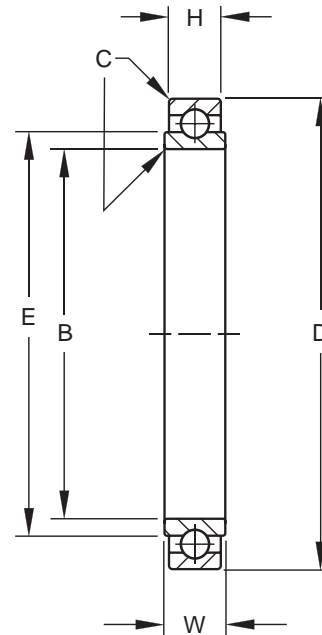

SPECIFICATIONS AND ORDERING INFORMATION

TO ORDER, SPECIFY BEARING NUMBER AND FACTORY SPECIFICATION. (Example B538 FS216)

Bearing Number	Bore B		Outside Diameter D		Widths W		H		E		C		Wt.		Radial Limit Load Rating	Thrust Limit Load Rating		
	+0.0007, -0.0007 +0.018, -0.018		+0.0000, -0.0010 +0.000, -0.025		+0.000, -0.005 +0.00, -0.13		+0.000, -0.005 +0.00, -0.13		Approx.		+0.015, -0.000 +0.38, -0.00		Approx.					
	in.	mm	in.	mm	in.	mm	in.	mm	in.	mm	in.	mm	lbs.	kg			lbf.	N
B538	0.6250	15.875	1.0625	26.988	0.281	7.14	0.250	6.35	0.781	19.84	0.015	0.38	0.02	0.009	3280	14600	1500	6700
B539	0.7500	19.050	1.1875	30.163	0.281	7.14	0.250	6.35	0.898	22.81	0.015	0.38	0.03	0.014	3750	16700	1700	7600
B540	0.8750	22.225	1.3125	33.338	0.281	7.14	0.250	6.35	1.019	25.88	0.015	0.38	0.04	0.018	4220	18800	1900	8500
B541	1.0625	26.988	1.5000	38.100	0.281	7.14	0.250	6.35	1.219	30.96	0.015	0.38	0.05	0.023	5000	22300	2200	9800
B542	1.3125	33.338	1.7500	44.450	0.281	7.14	0.250	6.35	1.454	36.93	0.015	0.38	0.07	0.032	5950	26500	2700	12000
B543	1.5625	39.688	2.0000	50.800	0.281	7.14	0.250	6.35	1.706	43.33	0.015	0.38	0.08	0.036	6880	30600	3200	14300
B544	1.8125 ⁽¹⁾	46.038 ⁽¹⁾	2.2500 ⁽²⁾	57.150 ⁽²⁾	0.281	7.14	0.250	6.35	1.974	50.14	0.015	0.38	0.09	0.041	7980	35500	3600	16000
B545	2.0625 ⁽¹⁾	52.388 ⁽¹⁾	2.6250 ⁽²⁾	66.675 ⁽²⁾	0.281	7.14	0.250	6.35	2.291	58.19	0.015	0.38	0.13	0.059	9220	41000	4000	17800
B546	2.3125 ⁽¹⁾	58.738 ⁽¹⁾	2.8750 ⁽²⁾	73.025 ⁽²⁾	0.281	7.14	0.250	6.35	2.531	64.29	0.015	0.38	0.15	0.068	10150	45200	4400	19600

⁽¹⁾ +0.0010 in. (+0.025mm), -0.0010 in. (-0.025mm).

⁽²⁾ +0.0000 in. (+0.000mm), -0.0015 in. (-0.038mm).

MS27646 • SAE-AS7949

- Extra light duty
- Single row, ball
- PTFE seals
- Exposed surfaces except bore and reinforced Teflon® shields are cadmium plated
- Prelubricated for life
- This series is dimensionally interchangeable with the unsealed B500 series
- Also offered with CRES 440C material and/or zinc nickel plating per OEM specifications

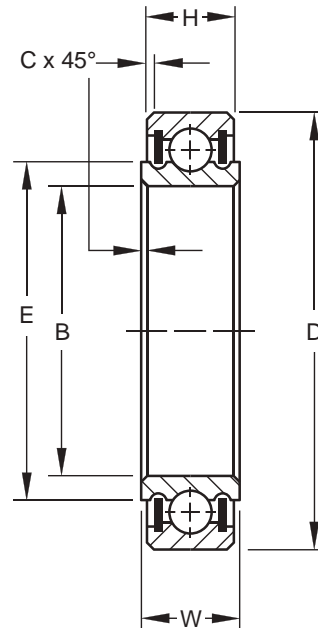

AIRFRAME CONTROL BALL BEARINGS

SPECIFICATIONS AND ORDERING INFORMATION

TO ORDER, SPECIFY BEARING NUMBER AND FACTORY SPECIFICATION. SEE TABLE 1 ON PG 8. (Example B538DD FS464)

Bearing Number	MS 27646 Dash No.	Bore B		Outside Diameter D		Widths		E	C	Wt.		Radial Limit Load Rating	Thrust Limit Load Rating						
		+0.0007, -0.0007 +0.018, -0.018		+0.0000, -0.0010 +0.000, -0.025		+0.000, -0.005 +0.00, -0.13	+0.000, -0.005 +0.00, -0.13			Approx.	+0.015-0.000 +0.38, -0.00			Approx.					
		in.	mm	in.	mm	in.	mm	in.	mm	in.	mm	lbs.	kg	lb.	N	lb.	N		
B538DD	-38	0.6250	15.875	1.0625	26.988	0.281	7.14	0.250	6.35	0.781	19.84	0.015	0.38	0.03	0.014	3280	14600	1500	6700
B539DD	-39	0.7500	19.050	1.1875	30.163	0.281	7.14	0.250	6.35	0.898	22.81	0.015	0.38	0.04	0.018	3750	16700	1700	7600
B540DD	-40	0.8750	22.225	1.3125	33.338	0.281	7.14	0.250	6.35	1.019	25.88	0.015	0.38	0.05	0.023	4220	18800	1900	8500
B541DD	-41	1.0625	26.988	1.5000	38.100	0.281	7.14	0.250	6.35	1.219	30.96	0.015	0.38	0.06	0.027	5000	22300	2200	9800
B542DD	-42	1.3125	33.338	1.7500	44.450	0.281	7.14	0.250	6.35	1.454	36.93	0.015	0.38	0.09	0.041	5950	26500	2700	12000
B543DD	-43	1.5625	39.688	2.0000	50.800	0.281	7.14	0.250	6.35	1.706	43.33	0.015	0.38	0.10	0.045	6880	30600	3200	14300
B544DD	-44	1.8125 ⁽¹⁾	46.038 ⁽¹⁾	2.2500 ⁽²⁾	57.150 ⁽²⁾	0.281	7.14	0.250	6.35	1.974	50.14	0.015	0.38	0.11	0.050	7980	35500	3600	16000
B545DD	-45	2.0625 ⁽¹⁾	52.388 ⁽¹⁾	2.6250 ⁽²⁾	66.675 ⁽²⁾	0.281	7.14	0.250	6.35	2.291	58.19	0.015	0.38	0.15	0.068	9220	41000	4000	17800
B546DD	-46	2.3125 ⁽¹⁾	58.738 ⁽¹⁾	2.8750 ⁽²⁾	73.025 ⁽²⁾	0.281	7.14	0.250	6.35	2.531	64.29	0.015	0.38	0.17	0.077	10150	45200	4400	19600

⁽¹⁾ +0.0010 in. (+0.025mm), -0.0010 in. (-0.025mm).

⁽²⁾ +0.0000 in. (+0.000mm), -0.0015 in. (-0.038mm).

K Series

- Single row, ball
- Exposed surfaces except bore and shields are cadmium plated
- PTFE seals or CRES shields
- Also offered with CRES 440C material and/or zinc nickel plating per OEM specifications

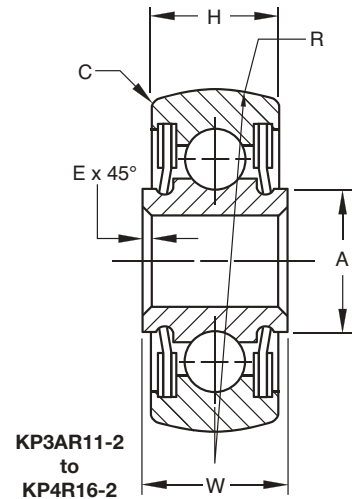
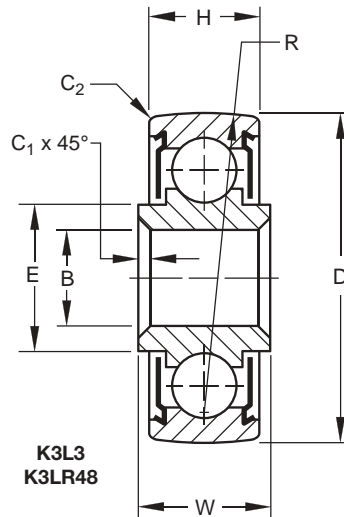
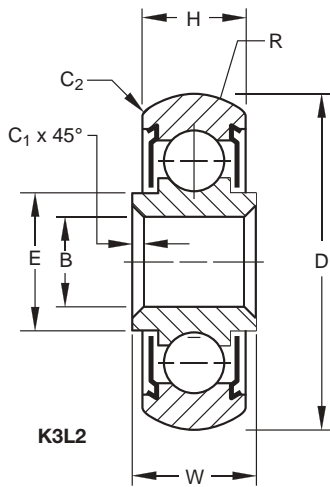

SPECIFICATIONS AND ORDERING INFORMATION

TO ORDER, SPECIFY BEARING NUMBER AND FACTORY SPECIFICATION. (Example K3L2 FS464)

Bearing Number	Bore B		Outside Diameter D		Widths				E		C ₁		C ₂		R	Max. Safe Working Load Radial ⁽¹⁾		Wt.		
	+0.0000, -0.0005 +0.00, -0.013				+0.000, -0.005 +0.000, -0.13		+0.000, -0.005 +0.000, -0.13		Approx.		+0.015, -0.000 +0.38, -0.00		(Ref.)			lb.	N	lbs.	kg	
	in.	mm	in.	mm	in.	mm	in.	mm	in.	mm	in.	mm	in.	mm	in.	mm				
*K3L2 ⁽²⁾	0.1900	4.826	0.687	17.45	0.245	6.22	0.203	5.16	0.275	6.98	0.005	0.13	0.020R	0.51	0.187	4.75	200	880	0.01	0.005
			0.685	17.40											0.182	4.62				
*K3L3 ⁽²⁾	0.1900	4.826	0.635	16.13	0.245	6.22	0.203	5.16	0.275	6.98	0.005	0.13	0.020R	0.51	0.550	13.97	200	880	0.01	0.005
			0.632	16.05											0.500	12.70				
K3LR48	0.1900	4.826	0.687	17.45	0.245	6.22	0.203	5.16	0.275	6.98	0.005	0.13	0.020R	0.51	3.015	76.58	200	880	0.02	0.009
			0.685	17.40											2.985	75.82				
KP3AR11-2	0.1900	4.826	0.718	18.24	0.297	7.54	0.265	6.73	0.297	7.54	0.005	0.13	0.015R	0.38	0.359	9.12	300	1330	0.02	0.009
			0.716	18.19											0.358	9.09				
KP4AR13	0.2500	6.350	0.800	20.32	0.281	7.14	0.219	7.39	0.375	9.53	0.005	0.13	0.015 x 45°	0.38	0.812	20.62	400	1780	0.02	0.009
			0.798	20.27											0.802	20.37				
KP4R16	0.2500	6.350	0.901	22.89	0.484	12.29	0.335	8.51	0.390	9.91	0.005	0.13	0.015 x 45°	0.38	1.000	25.40	400	1780	0.04	0.018
			0.899	22.83											0.990	25.15				
KP4R16-2	0.2500	6.350	1.000	25.40	0.390	9.91	0.335	8.51	0.390	9.91	0.005	0.13	0.015 x 45°	0.38	1.000	25.40	500	2220	0.06	0.027
			0.998	25.35											0.990	25.15				

⁽¹⁾ The maximum working radial load to obtain 100,000 ft. (30,500m) peripheral travel life.

⁽²⁾ Prepacked with lubricant conforming to MIL-PRF-23827 Type 1. Equipped with CRES shields.

*Check for availability.

AIRFRAME CONTROL BALL BEARINGS

MS21443 • SAE-AS7949 Pulley Series

- PTFE seals and CRES sealcaps
- Exposed surfaces except bore, caps, and seals are cadmium plated

- Prelubricated for life
- Retainer type (except P8)
- For MIL-P-7034 pulleys

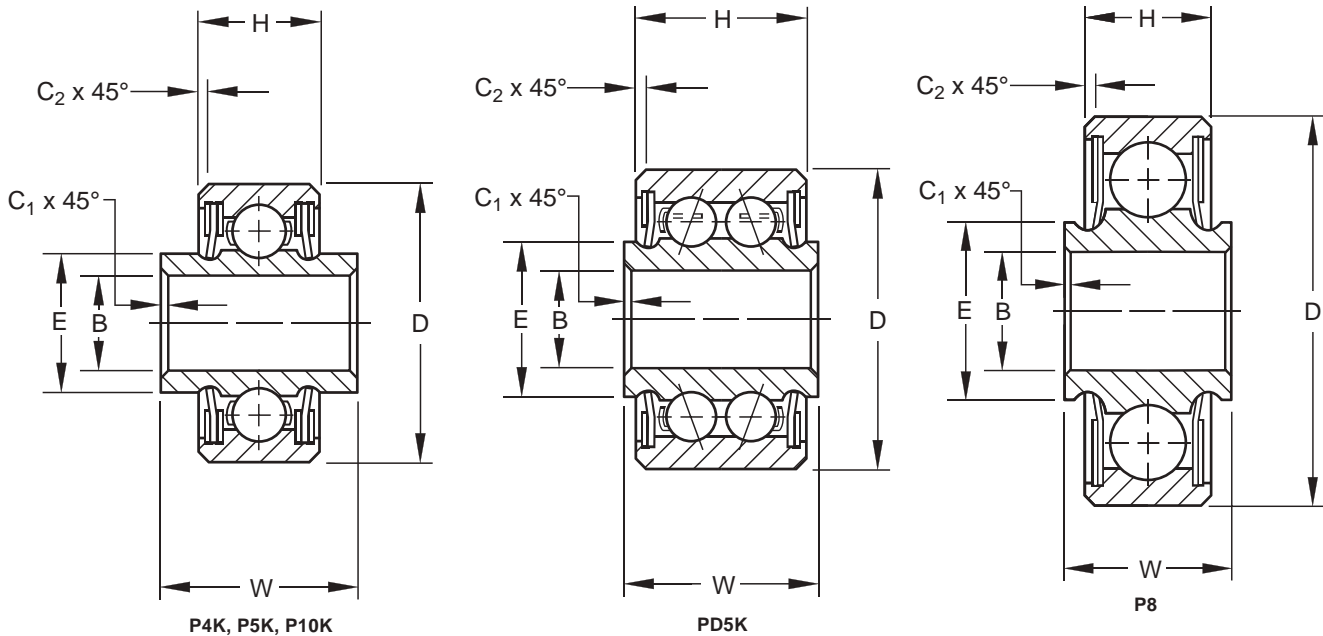

AIRFRAME CONTROL BALL BEARINGS

SPECIFICATIONS AND ORDERING INFORMATION

TO ORDER, SPECIFY BEARING NUMBER AND FACTORY SPECIFICATION. SEE TABLE 1 ON PG 8. (Example MKP3L FS464)

Bearing Number	MS 21443 Dash No.	Bore B		Outside Diameter D		Widths				E		C ₁		C ₂		Wt.		Radial Limit Load Rating	Thrust Limit Load Rating		
		in.	mm	in.	mm	in.	mm	in.	mm	in.	mm	in.	mm	in.	mm	lbs.	kg		lb.	N	lb.
P4K	4B	0.2500	6.350	0.8750	22.225	0.438	11.13	0.375	9.52	0.423	10.74	0.005	0.13	0.022	0.56	0.04	0.018	1710	7600	800	3550
P5K	5A	0.3125	7.938	0.8750	22.225	0.625	15.88	0.375	9.52	0.455	11.56	0.005	0.13	0.022	0.56	0.04	0.018	1710	7600	800	3550
PD5K	5B	0.3125	7.938	0.9375	23.812	0.625	15.88	0.563	14.30	0.455	11.56	0.005	0.13	0.022	0.56	0.07	0.032	3420	15200	1030	4600
P8 ⁽¹⁾	8	0.5000	12.700	1.6875	42.862	0.750	19.05	0.563	14.30	0.768	19.51	0.005	0.13	0.032	0.81	0.24	0.109	11800	52500	5200	23200
P10K	10	0.6250	15.875	1.1875	30.162	0.438	11.13	0.375	9.52	0.769	19.53	0.005	0.13	0.022	0.56	0.06	0.027	2440	10800	1100	4900

⁽¹⁾ Full type — No retainer.

Note: Although the P Series bearings are designed for use in pulleys, they are well suited for use in other airframe applications.

MS21443 • SAE-AS7949 Pulley Series

- Single row, ball, heavy duty
- PTFE seals and CRES sealcaps
- Exposed surfaces except bore, caps, and seals are cadmium plated
- Prelubricated for life
- Retainer type
- For MIL-P-7034 pulleys
- Also offered with CRES 440C material and/or zinc nickel plating per OEM specifications

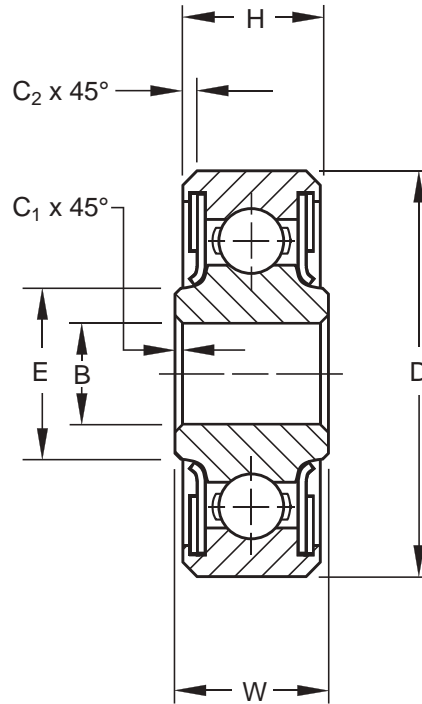

AIRFRAME CONTROL BALL BEARINGS

SPECIFICATIONS AND ORDERING INFORMATION

TO ORDER, SPECIFY BEARING NUMBER AND FACTORY SPECIFICATION. SEE TABLE 1 ON PG 8. (Example KP3K FS464)

Bearing Number	MS 21443 Dash No.	Bore B		Outside Diameter D		Widths				E	C ₁		C ₂		Wt.		Radial Limit Load Rating	Thrust Limit Load Rating			
						W		H							Approx.						
		in.	mm	in.	mm	in.	mm	in.	mm	in.	mm	in.	mm	in.	mm	lbs.	kg	lbf.	N	lbf.	N
*KP3K	3B	0.1900	4.826	0.7774	19.746	0.297	7.54	0.270	6.86	0.332	8.43	0.005	0.13	0.024	0.61	0.02	0.009	1090	4800	600	2650
*KP3AK	3A	0.1900	4.826	0.6250	15.875	0.297	7.54	0.234	5.94	0.297	7.54	0.005	0.13	0.016	0.41	0.01	0.005	705	3150	385	1700
*KP3AK-2 ⁽¹⁾	-	0.1900	4.826	0.6250	15.875	0.625	15.88	0.234	5.94	0.297	7.54	0.005	0.13	0.016	0.41	0.02	0.009	705	3150	385	1700
*W4AK	4A	0.2500	6.350	0.7500	19.050	0.438	11.13	0.312	7.92	0.372	9.45	0.005	0.13	0.016	0.41	0.03	0.014	1090	4800	600	2650
*KP4K	4C	0.2500	6.350	0.9014	22.896	0.484	12.29	0.335	8.51	0.390	9.91	0.005	0.13	0.034	0.86	0.04	0.018	1710	7600	800	3550

⁽¹⁾ Not used in MIL-P-7034 pulleys.

Note: Although the P Series bearings are designed for use in pulleys, they are well suited for use in other airframe applications.

*Check for availability.

MS27640-R • SAE-AS7949

- Single row, ball, heavy duty
- PTFE seals and CRES sealcaps
- Exposed surfaces except bore, caps, and seals are cadmium plated
- Prelubricated for life
- Also offered with CRES 440C material and/or zinc nickel plating per OEM specifications

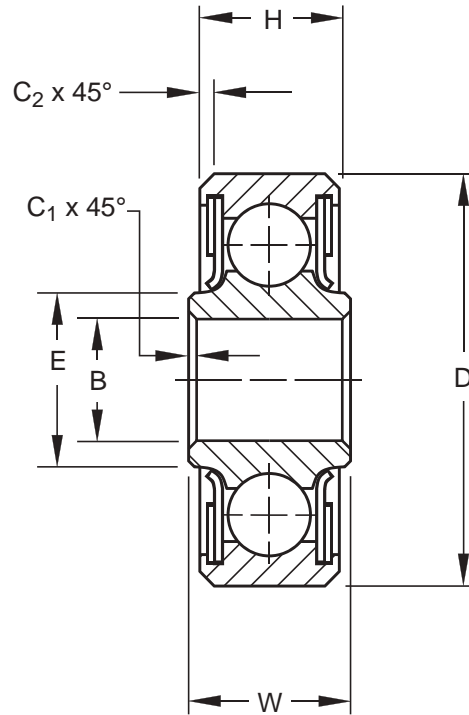

AIRFRAME CONTROL BALL BEARINGS

SPECIFICATIONS AND ORDERING INFORMATION

TO ORDER, SPECIFY BEARING NUMBER AND FACTORY SPECIFICATION. SEE TABLE 1 ON PG 8. (Example MKP3L FS464)

Bearing Number 52100 [†]	MS 27640 Dash No.	Bore B		Outside Diameter D		Widths		E	C ₁		C ₂		Wt.		Radial Limit Load Rating	Thrust Limit Load Rating					
		+0.0000, -0.0003 +0.000, -0.008		+0.0000, -0.0004 +0.000, -0.010		+0.0000, -0.0025 +0.000, -0.064			+0.000, -0.005 +0.00, -0.13		+0.015, -0.000 +0.38, -0.00		+0.015, -0.000 +0.38, -0.00				Approx.				
		in.	mm	in.	mm	in.	mm	in.	mm	in.	mm	in.	mm	lbs.	kg	lbf.	N				
MKP3L ⁽¹⁾	-3AR	0.1900	4.826	0.6250	15.875	0.2450	6.225	0.203	5.16	0.285	7.24	0.005	0.13	0.010	0.25	0.01	0.005	1560	6900	700	3100
MKP3	-3R	0.1900	4.826	0.7774	19.746	0.2970	7.540	0.270	6.86	0.336	8.53	0.005	0.13	0.022	0.56	0.03	0.014	1880	8400	900	4000
MKP4	-4R	0.2500	6.350	0.9014	22.896	0.4840	12.290	0.335	8.51	0.395	10.03	0.005	0.13	0.032	0.81	0.04	0.018	2680	12000	1200	5300
MKP5	-5R	0.3125	7.938	1.2500	31.750	0.5580	14.170	0.375	9.53	0.474	12.04	0.015	0.38	0.032	0.81	0.09	0.041	5620	25000	2500	11200
MKP6	-6R	0.3750	9.525	1.4375	36.513	0.6200	15.750	0.469	11.91	0.596	15.14	0.015	0.38	0.032	0.81	0.15	0.068	7910	35500	3500	15600
MKP8	-8R	0.5000	12.700	1.6875	42.863	0.6200	15.750	0.500	12.70	0.773	19.63	0.015	0.38	0.044	1.12	0.21	0.095	11800	52500	5200	23200
MKP10	-10R	0.6250	15.875	1.9375	49.213	0.6200	15.750	0.500	12.70	0.855	21.72	0.015	0.38	0.044	1.12	0.28	0.127	14100	62800	6200	27600

⁽¹⁾ Bonded PTFE Seals

[†]For CRES 440C material prefix "A" in part number; e.g., AMKP3L

MS27641-R • SAE-AS7949

- Single row, ball, deep groove, medium duty
- PTFE seals and CRES sealcaps
- Exposed surfaces except bore, caps, and seals are cadmium plated
- Prelubricated for life
- Also offered with CRES 440C material and/or zinc nickel plating per OEM specifications

AIRFRAME CONTROL BALL BEARINGS

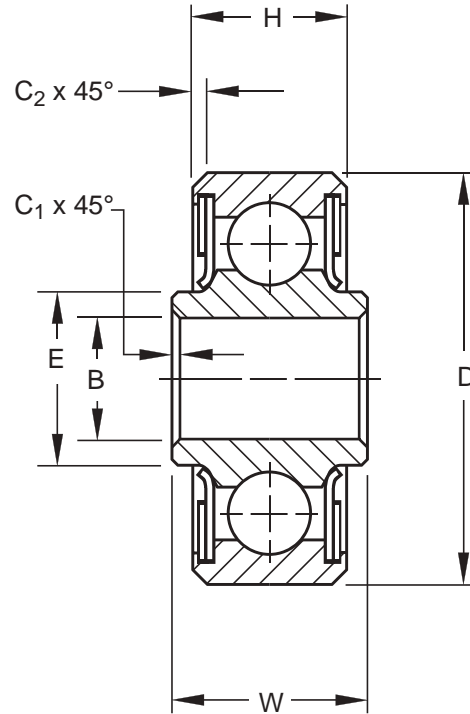

SPECIFICATIONS AND ORDERING INFORMATION

TO ORDER, SPECIFY BEARING NUMBER AND FACTORY SPECIFICATION. SEE TABLE 1 ON PG 8. (Example MKP3AL FS464)

Bearing Number 52100 [†]	MS 27641 Dash No.	Bore B		Outside Diameter D		Widths				E		C ₁		C ₂		Wt.		Radial Limit Load Rating	Thrust Limit Load Rating		
		+0.0000, -0.0003 +0.000, -0.008		+0.0000, -0.0004 +0.000, -0.010		+0.0000, -0.0025 +0.000, -0.064		+0.000, -0.005 +0.00, -0.13		Approx.		+0.015, -0.000 +0.38, -0.00		+0.015, -0.000 +0.38, -0.00		Approx.					
		in.	mm	in.	mm	in.	mm	in.	mm	in.	mm	in.	mm	in.	mm	lbs.	kg			lb.	N
MKP3AL ⁽¹⁾	—	0.1900	4.826	0.5000	12.700	0.2370	6.020	0.196	4.98	0.261	6.63	0.005	0.13	0.012	0.30	0.01	0.005	970	4350	430	1950
MKP3A	-3R	0.1900	4.826	0.6250	15.875	0.2970	7.540	0.234	5.94	0.302	7.67	0.005	0.13	0.016	0.41	0.01	0.005	1560	6950	700	3150
MKP4A	-4R	0.2500	6.350	0.7500	19.050	0.2810	7.140	0.219	5.56	0.385	9.78	0.005	0.13	0.016	0.41	0.02	0.009	1880	8400	900	4000
MKP5A	-5R	0.3125	7.938	0.8125	20.638	0.2970	7.540	0.234	5.94	0.433	11.00	0.015	0.38	0.016	0.41	0.02	0.009	2190	9800	1000	4500
MKP6A	-6R	0.3750	9.525	0.8750	22.225	0.3130	7.950	0.250	6.35	0.512	13.00	0.015	0.38	0.016	0.41	0.03	0.014	2500	11200	1100	4900
MKP8A	-8R	0.5000	12.700	1.1250	28.575	0.3750	9.530	0.313	7.95	0.638	16.21	0.015	0.38	0.016	0.41	0.05	0.023	3910	17400	1700	7600
MKP10A	-10R	0.6250	15.875	1.3750	34.925	0.4060	10.310	0.344	8.74	0.773	19.63	0.015	0.38	0.032	0.81	0.08	0.036	6700	30000	3000	13400
MKP12A	-12R	0.7500	19.050	1.6250	41.275	0.4370	11.100	0.375	9.53	0.967	24.56	0.015	0.38	0.032	0.81	0.13	0.059	8790	39100	3900	17400
MKP16A	-16R	1.0000	25.400	2.0000	50.800	0.5000	12.700	0.438	11.13	1.268	32.21	0.015	0.38	0.032	0.81	0.22	0.100	11900	53000	5200	23200
MKP20A	-20R	1.2500	31.750	2.2500	57.150	0.5000	12.700	0.438	11.13	1.503	38.18	0.015	0.38	0.032	0.81	0.26	0.118	13800	61400	6100	27200

⁽¹⁾ MKP3AL is not an MS27641 size.

[†] For CRES 440C material prefix "A" in part number; e.g., AMKP3L

MS27645-R • SAE-AS7949

- Single row, ball, self-aligning light and heavy duty
- PTFE seals and CRES sealcaps
- Exposed surfaces except bore, caps, and seals are cadmium plated
- Prelubricated for life
- Also offered with CRES 440C material and/or zinc nickel plating per OEM specifications

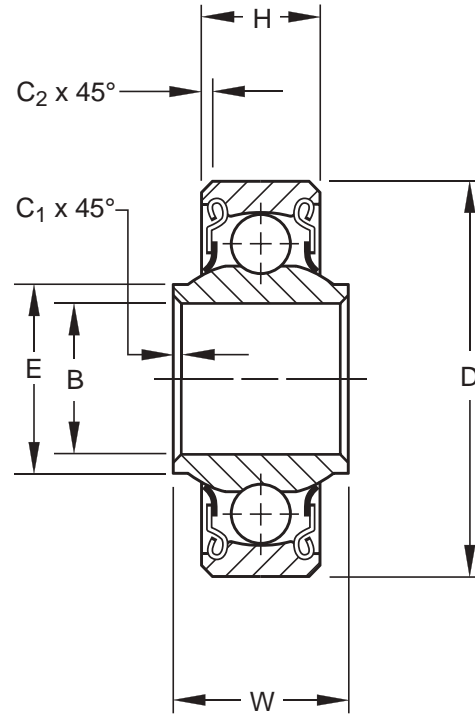

AIRFRAME CONTROL BALL BEARINGS

SPECIFICATIONS AND ORDERING INFORMATION

TO ORDER, SPECIFY BEARING NUMBER AND FACTORY SPECIFICATION. SEE TABLE 1 ON PG 8. (Example MKSP3L FS464)

Bearing Number ⁽¹⁾	MS 27645 Dash No.	Bore B		Outside Diameter D		Widths				E		C ₁		C ₂		Wt.		Radial Limit Load Rating	Thrust Limit Load Rating		
		+0.0000, -0.0003 +0.000, -0.008		+0.0000, -0.0004 +0.000, -0.010		+0.0000, -0.0025 +0.000, -0.064		+0.000, -0.005 +0.00, -0.13		Approx.		+0.015-0.000 +0.38-0.00		+0.015-0.000 +0.38-0.00		Approx.					
		in.	mm	in.	mm	in.	mm	in.	mm	in.	mm	in.	mm	in.	mm	lbs.	kg			lb.	N
MKSP3L	-3AR	0.1900	4.826	0.6250	15.875	0.2450	6.220	0.203	5.16	0.256	6.50	0.005	0.13	0.016	0.41	0.01	0.005	550	2450	100	450
MKSP4A	-4AR	0.2500	6.350	0.7500	19.050	0.2810	7.140	0.219	5.56	0.328	8.33	0.005	0.13	0.016	0.41	0.02	0.009	900	4000	200	900
MKSP5A	-5AR	0.3125	7.938	0.8125	20.638	0.2970	7.540	0.234	5.94	0.389	9.88	0.015	0.38	0.016	0.41	0.02	0.009	1000	4400	200	900
MKSP6A	-6AR	0.3750	9.525	0.8750	22.225	0.3130	7.950	0.250	6.35	0.462	11.73	0.016	0.41	0.016	0.41	0.03	0.014	1120	5000	200	900
MKSP3	-3R	0.1900	4.826	0.7774	19.746	0.2970	7.540	0.270	6.86	0.297	7.54	0.005	0.13	0.022	0.56	0.03	0.014	900	4000	200	900
MKSP4	-4R	0.2500	6.350	0.9014	22.896	0.4840	12.290	0.335	8.51	0.396	10.06	0.005	0.13	0.032	0.81	0.04	0.018	1410	6300	300	1340
MKSP5	-5R	0.3125	7.938	1.2500	31.750	0.5580	14.170	0.375	9.52	0.567	14.40	0.015	0.38	0.032	0.81	0.10	0.045	2190	9800	300	1340
MKSP6	-6R	0.3750	9.525	1.4375	36.512	0.6200	15.750	0.469	11.91	0.612	15.54	0.015	0.38	0.032	0.81	0.15	0.068	2980	13200	400	1780
*MKSP8	-8R	0.5000	12.700	1.6875	42.862	0.6200	15.750	0.500	12.70	0.796	20.22	0.015	0.38	0.044	1.12	0.23	0.104	3670	16300	500	2230
*MKSP10	-10R	0.6250	15.875	1.9375	49.212	0.8130	20.650	0.625	15.88	0.922	23.42	0.015	0.38	0.044	1.12	0.37	0.168	5320	23600	600	2670

⁽¹⁾ These bearings are self-aligning for 10° in either direction except MKSP4A, MKSP5A and MKSP6A which are self-aligning for 8° in either direction.

* Check for availability.

MS27642-S

- Single row, ball, deep groove, light duty
- PTFE seals and CRES sealcaps
- Exposed surfaces except bore, caps, and seals are cadmium plated
- Prelubricated for life
- Also offered with CRES 440C material and/or zinc nickel plating per OEM specifications

AIRFRAME CONTROL BALL BEARINGS

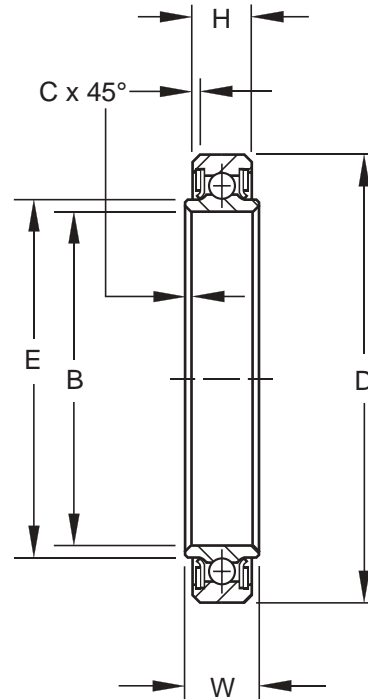

SPECIFICATIONS AND ORDERING INFORMATION

TO ORDER, SPECIFY BEARING NUMBER AND FACTORY SPECIFICATION. SEE TABLE 1 ON PG 8. (Example MKP16B)

Bearing Number 52100 [†]	MS 27642 Dash No.	Bore B		Outside Diameter D		Widths		E	C	Wt.		Radial Limit Load Rating		Thrust Limit Load Rating					
		+0.0000, -0.0005 +0.000, -0.013		+0.0000, -0.0010 +0.000, -0.025		+0.0000, -0.0025 +0.000, -0.064				+0.000, -0.005 +0.00, -0.13		Approx.		+0.015, -0.000 +0.38, -0.00		Approx.			
		in.	mm	in.	mm	in.	mm	in.	mm	in.	mm	lbs.	kg	lbf.	N	lbf.	N		
MKP16B	-16S	1.0000	25.400	1.7500	44.450	0.4370	11.100	0.375	9.53	1.150	29.21	0.024	0.61	0.14	0.064	8090	36000	3600	16000
MKP21B	-21S	1.3125	33.338	2.0625	52.388	0.4370	11.100	0.375	9.53	1.465	37.21	0.024	0.61	0.16	0.073	9840	43800	4400	19600
MKP23B	-23S	1.4375	36.512	2.1875	55.563	0.4370	11.100	0.375	9.53	1.585	40.26	0.024	0.61	0.17	0.077	10500	46700	4700	20900
MKP25B	-25S	1.5625	39.688	2.3125	58.738	0.4370	11.100	0.375	9.53	1.700	43.18	0.024	0.61	0.19	0.086	11300	50300	5000	22300
MKP29B	-29S	1.8125	46.038	2.5625	65.088	0.4370	11.100	0.375	9.53	1.940	49.28	0.024	0.61	0.21	0.095	12700	56500	5600	25000
MKP33B	-33S	2.0625	52.388	2.8125	71.438	0.4370	11.100	0.375	9.53	2.234	56.74	0.024	0.61	0.23	0.104	14400	64000	6400	28600
MKP37B	-37S	2.3125	58.738	3.0625	77.788	0.4370	11.100	0.375	9.53	2.475	62.87	0.024	0.61	0.26	0.118	15800	70300	7000	31100
MKP47B	-47S	2.9375	74.612	3.8750	98.425	0.5310	13.490	0.469	11.91	3.105	78.87	0.039	0.99	0.49	0.222	24700	110000	10900	48500
MKP49B	-49S	3.0625	77.788	4.0000	101.600	0.5310	13.490	0.469	11.91	3.230	82.04	0.039	0.99	0.53	0.240	27500	122500	12100	54000
MKP52B	-52S	3.2500	85.550	4.1875	106.363	0.5310	13.490	0.469	11.91	3.460	87.88	0.039	0.99	0.55	0.249	28700	12770	12600	56000
MKP56B	-56S	3.5000	88.900	4.4375	112.713	0.5310	13.490	0.469	11.91	3.734	94.84	0.039	0.99	0.59	0.268	31200	140000	13700	61000
MKP60B	-60S	3.7500	95.250	4.6875	119.063	0.5310	13.490	0.469	11.91	3.972	100.89	0.039	0.99	0.61	0.277	33100	147300	14600	65000
MKP64B	-64S	4.0000	101.600	4.9375	125.413	0.5310	13.490	0.469	11.91	4.217	107.11	0.039	0.99	0.64	0.290	35500	157900	15400	68500
MKP68B	-68S	4.2500	107.950	5.3125	134.938	0.5930	15.060	0.531	13.49	4.478	113.74	0.039	0.99	0.73	0.331	41900	186400	18400	81800
MKP72B	-72S	4.5000	114.300	5.5625	142.875	0.5930	15.060	0.531	13.49	4.736	120.29	0.039	0.99	0.76	0.345	44300	197000	19500	86700

[†] For CRES 440C material prefix "A" in part number; e.g., AMKP21B

MKP-BS Precision Series

- Single row, ball, externally self-aligning, extra light duty
- PTFE seals and CRES sealcaps
- Exposed surfaces except bore, caps, and seals are cadmium plated
- Pre-lubricated for life
- This series is internally identical to the MKP-B series. Self-alignment is provided by an external self-aligning ring whose internal spherical-ground surface is accurately matched to the external spherical-ground surface of the outer ring. These bearings are designed to compensate for initial misalignment
- Also offered with CRES 440C material and/or zinc nickel plating per OEM specifications

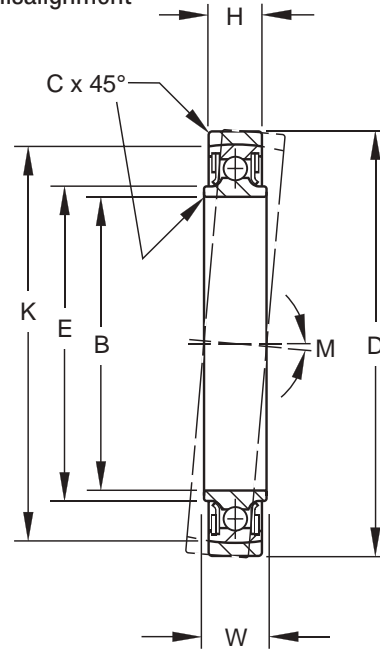

AIRFRAME CONTROL BALL BEARINGS

SPECIFICATIONS AND ORDERING INFORMATION

TO ORDER, SPECIFY BEARING NUMBER AND FACTORY SPECIFICATION. SEE TABLE 1 ON PG 8. (Example MKP16BS FS464)

Bearing Number 52100 [†]	Bore B		Outside Diameter D		Widths				E	C		K To Sharp Corner (Ref.)	M Mis-alignment Either Direction (Ref.)	Wt.		Radial Limit Load Rating	Thrust Limit Load Rating				
	+0.0000, -0.0005 +0.000, -0.013		+0.0000, -0.0010 +0.000, -0.025		+0.0000, -0.0025 +0.000, -0.064		+0.000, -0.005 +0.00, -0.13			Approx.	+0.015, -0.000 +0.38, -0.00			Approx.							
	in.	mm	in.	mm	in.	mm	in.	mm	in.	mm	in.	mm	lbs.	kg	lbf.	N	lbf.	N			
MKP16BS	1.0000	25.400	1.9375	49.213	0.4370	11.100	0.375	9.53	1.150	29.21	0.024	0.61	1.709	43.41	7°25'	0.18	0.082	8085	36000	1600	7100
MKP21BS	1.3125	33.338	2.2500	57.150	0.4370	11.100	0.375	9.53	1.465	37.21	0.024	0.61	2.028	51.51	6°30'	0.20	0.091	9840	43800	2000	9000
*MKP23BS	1.4375	36.612	2.3750	60.325	0.4370	11.100	0.375	9.53	1.585	40.26	0.024	0.61	2.155	54.74	6°	0.22	0.100	10500	46700	2200	9800
MKP25BS	1.5625	39.688	2.5000	63.500	0.4370	11.100	0.375	9.53	1.700	43.18	0.024	0.61	2.282	57.96	5°45'	0.25	0.113	11300	50300	2300	10200
MKP29BS	1.8125	46.038	2.7500	69.850	0.4370	11.100	0.375	9.53	1.940	49.28	0.024	0.61	2.535	64.39	5°	0.27	0.122	12700	56500	2600	11600
*MKP33BS	2.0625	52.388	3.0000	76.200	0.4370	11.100	0.375	9.53	2.234	56.74	0.024	0.61	2.787	70.79	5°	0.30	0.136	14400	64000	2900	12900
*MKP37BS	2.3125	58.738	3.2500	82.550	0.4370	11.100	0.375	9.53	2.475	62.87	0.024	0.61	3.039	77.19	4°30'	0.33	0.150	15800	70300	3200	14300
*MKP47BS	2.9375	74.612	4.1250	104.775	0.5310	13.490	0.469	11.91	3.105	78.87	0.039	0.99	3.846	97.69	4°30'	0.64	0.290	24700	110000	5000	22300
MKP48BS	3.0000	76.200	4.2500	107.950	0.5310	13.490	0.469	11.91	3.230	82.04	0.039	0.99	3.972	100.89	4°	0.69	0.313	27500	122000	5500	24500
MKP49BS	3.0625	77.788	4.2500	107.950	0.5310	13.490	0.469	11.91	3.230	82.04	0.039	0.99	3.972	100.89	4°	0.69	0.313	27500	122000	5500	24500

* Check for availability.

[†] For CRES 440C material prefix "A" in part number; e.g., AMKP16BS

MB500 Precision Series

- Extra light duty
- Single row, ball
- This series is made of bearing quality chromium alloy, high carbon steel, and is not cadmium plated
- Open type – no seals or shields (unsealed version of MB500DD)
- Package/shipped with preservative oil
- Also offered with CRES 440C material per OEM specification

AIRFRAME CONTROL BALL BEARINGS

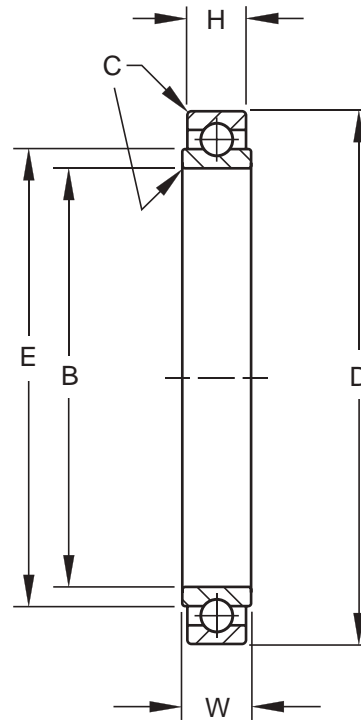

SPECIFICATIONS AND ORDERING INFORMATION

TO ORDER, SPECIFY BEARING NUMBER AND FACTORY SPECIFICATION. (Example MB538 FS216)

Bearing Number 52100 [†]	Bore B		Outside Diameter D		Widths W		H	E	C	Wt.		Radial Limit Load Rating	Thrust Limit Load Rating					
	in.	mm	in.	mm	in.	mm	in.	mm	in.	mm	lbs.	kg	lbf.	N				
MB538	0.6250	15.875	1.0625	26.988	0.2810	7.140	0.250	6.35	0.781	19.84	0.015	0.38	0.02	0.009	3280	14600	1500	6700
MB539	0.7500	19.050	1.1875	30.163	0.2810	7.140	0.250	6.35	0.898	22.81	0.015	0.38	0.03	0.014	3750	16700	1700	7600
MB540	0.8750	22.225	1.3125	33.338	0.2810	7.140	0.250	6.35	1.019	25.88	0.015	0.38	0.04	0.018	4220	18800	1900	8500
MB541	1.0625	26.988	1.5000	38.100	0.2810	7.140	0.250	6.35	1.219	30.96	0.015	0.38	0.05	0.023	5000	22300	2200	9800
MB542	1.3125	33.338	1.7500	44.450	0.2810	7.140	0.250	6.35	1.454	36.93	0.015	0.38	0.07	0.032	5950	26500	2700	12000
MB543	1.5625	39.688	2.0000	50.800	0.2810	7.140	0.250	6.35	1.706	43.33	0.015	0.38	0.08	0.036	6880	30600	3200	14300
MB544	1.8125 ⁽¹⁾	46.038 ⁽¹⁾	2.2500 ⁽²⁾	57.150 ⁽²⁾	0.2810	7.140	0.250	6.35	1.974	50.14	0.015	0.38	0.09	0.041	7980	35500	3600	16000
MB545	2.0625 ⁽¹⁾	52.388 ⁽¹⁾	2.6250 ⁽²⁾	66.675 ⁽²⁾	0.2810	7.140	0.250	6.35	2.291	58.19	0.015	0.38	0.13	0.059	9220	41000	4000	17800
*MB546	2.3125 ⁽¹⁾	58.738 ⁽¹⁾	2.8750 ⁽²⁾	73.025 ⁽²⁾	0.2810	7.140	0.250	6.35	2.531	64.29	0.015	0.38	0.15	0.068	10150	45200	4400	19600

⁽¹⁾ +.0000 in. (+.000mm), -.0008 in. (-.020mm).

⁽²⁾ +.0000 in. (+.000mm), -.0007 in. (-.018mm).

* Check for availability.

[†] For CRES 440C material prefix "A" in part number; e.g., AMB538

MS21428 • SAE-AS7949

- Extra light duty
- Single row, ball, torque tube type
- PTFE seals
- Exposed surfaces except bore and reinforced Teflon® shields are cadmium plated
- Prelubricated for life
- This series is dimensionally interchangeable with the unsealed MB500 series
- Also offered with CRES 440C material and/or zinc nickel plating per OEM specifications

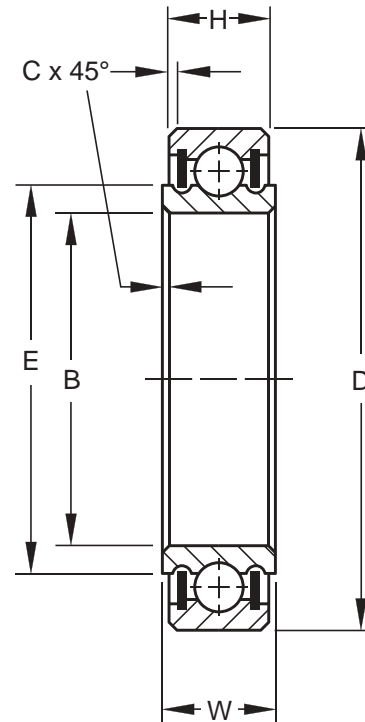

AIRFRAME CONTROL BALL BEARINGS

SPECIFICATIONS AND ORDERING INFORMATION

TO ORDER, SPECIFY BEARING NUMBER AND FACTORY SPECIFICATION. SEE TABLE 1 ON PG 8. (Example MB538DD FS464)

Bearing Number	MS 21428 Dash No.	Bore B		Outside Diameter D		Widths		E	C	Wt.		Radial Limit Load Rating	Thrust Limit Load Rating						
						W	H			Approx.									
		in.	mm	in.	mm	in.	mm	in.	mm	lbs.	kg	lbf.	N	lbf.	N				
MB538DD	-38	0.6250	15.875	1.0625	26.988	0.2810	7.140	0.250	6.35	0.781	19.84	0.015	0.38	0.03	0.014	3280	14600	1500	6700
MB539DD	-39	0.7500	19.050	1.1875	30.163	0.2810	7.140	0.250	6.35	0.898	22.81	0.015	0.38	0.04	0.018	3750	16700	1700	7600
MB540DD	-40	0.8750	22.225	1.3125	33.338	0.2810	7.140	0.250	6.35	1.019	25.88	0.015	0.38	0.05	0.023	4220	18800	1900	8500
MB541DD	-41	1.0625	26.988	1.5000	38.100	0.2810	7.140	0.250	6.35	1.219	30.96	0.015	0.38	0.06	0.027	5000	22300	2200	9800
MB542DD	-42	1.3125	33.338	1.7500	44.450	0.2810	7.140	0.250	6.35	1.454	36.93	0.015	0.38	0.09	0.041	5950	26500	2700	12000
MB543DD	-43	1.5625	39.688	2.0000	50.800	0.2810	7.140	0.250	6.35	1.706	43.33	0.015	0.38	0.1	0.045	6880	30600	3200	14300
MB544DD	-44	1.8125 ⁽¹⁾	46.038 ⁽¹⁾	2.2500 ⁽²⁾	57.150 ⁽²⁾	0.2810	7.140	0.250	6.35	1.974	50.14	0.015	0.38	0.11	0.05	7980	35500	3600	16000
MB545DD	-45	2.0625 ⁽¹⁾	52.388 ⁽¹⁾	2.6250 ⁽²⁾	66.675 ⁽²⁾	0.2810	7.140	0.250	6.35	2.291	58.19	0.015	0.38	0.15	0.068	9220	41000	4000	17800
MB546DD	-46	2.3125 ⁽¹⁾	58.738 ⁽¹⁾	2.8750 ⁽²⁾	73.025 ⁽²⁾	0.2810	7.140	0.250	6.35	2.531	64.29	0.015	0.38	0.17	0.077	10150	45200	4400	19600

(1) +.0000 in. (+.000mm), -.0008 in. (-.020mm).

(2) +.0000 in. (+.000mm), -.0007 in. (-.018mm).

*Check for availability.

†For CRES 440C material prefix "A" in part number; e.g., AMB538DD

MS27644 • SAE-AS7949 (DPP Series only)

- Double row, ball, light and heavy duty
- PTFE seals and CRES sealcaps
- Exposed surfaces except bore, caps and seals are cadmium plated
- Pre-lubricated for life
- For use where high moment rigidity is required, DPP-W series only
- Also offered with CRES 440C material and/or zinc nickel plating per OEM specifications

AIRFRAME CONTROL BALL BEARINGS

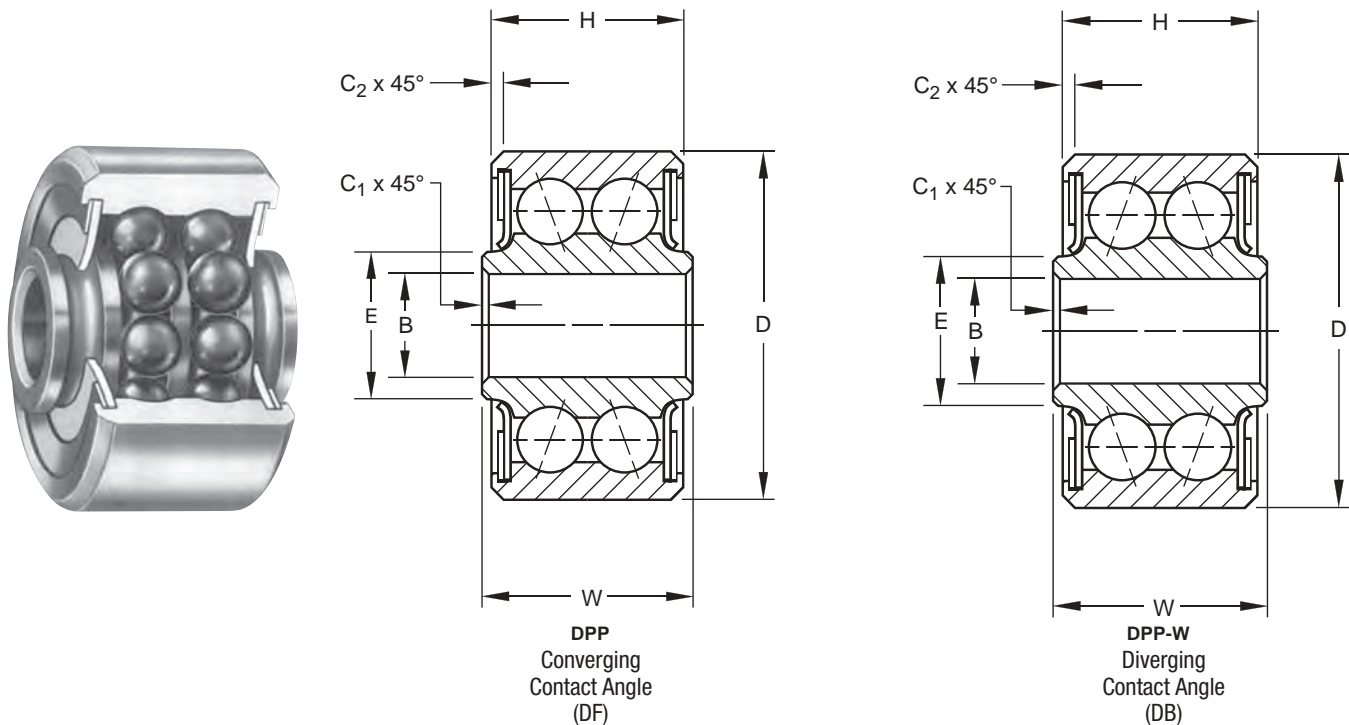

SPECIFICATIONS AND ORDERING INFORMATION

TO ORDER, SPECIFY BEARING NUMBER AND FACTORY SPECIFICATION. SEE TABLE 1 ON PG 8. (Example DPP3 FS464)

Bearing Number	MS 27644 Dash No.	Bore B		Outside Diameter D		Widths				E	C ₁		C ₂		Wt. Approx.	Radial Limit Load Rating	Thrust Limit Load Rating				
		in.	mm	in.	mm	W	H	in.	mm		in.	mm	in.	mm				lbs.	kg	lbf.	N
		+0.0000, -0.0005 +0.000, -0.013		+0.0000, -0.0005 +0.000, -0.013		+0.0000, -0.0005 +0.000, -0.013		+0.000, -0.0005 +0.00, -0.13		Approx.		+0.015, -0.000 +0.38, -0.00		+0.015, -0.000 +0.38, -0.00							
DPP3	-3	0.1900	4.826	0.7774	19.746	0.495	12.57	0.473	12.01	0.302	7.67	0.005	0.13	0.018	0.46	0.04	0.018	2950	13200	1700	7500
DPP4	-4	0.2500	6.350	0.9014	22.896	0.620	15.75	0.491	12.47	0.410	10.41	0.005	0.13	0.032	0.81	0.06	0.027	5370	24000	1800	8000
DPP5	-5	0.3125	7.938	1.2500	31.750	0.745	18.92	0.687	17.45	0.524	13.31	0.015	0.38	0.032	0.81	0.17	0.077	11000	49000	4000	17800
DPP6	-6	0.3750	9.525	1.4375	36.512	0.870	22.10	0.794	20.17	0.610	15.49	0.015	0.38	0.032	0.81	0.26	0.118	15760	70000	5300	23600
DPP8	-8	0.5000	12.700	1.6875	42.862	0.932	23.67	0.856	21.74	0.735	18.67	0.015	0.38	0.044	1.12	0.38	0.172	23600	105000	7800	34700
*DPP10	-10	0.6250	15.875	1.9375	49.212	0.995	25.27	0.920	23.37	0.890	22.61	0.015	0.38	0.044	1.12	0.53	0.240	28400	126000	9400	41800
*DPP3W	-	0.1900	4.826	0.7774	19.746	0.495	12.57	0.473	12.01	0.297	7.54	0.005	0.13	0.018	0.46	0.04	0.018	28400	13200	1450	6400
DPP4W	-	0.2500	6.350	0.9014	22.896	0.620	15.75	0.491	12.47	0.405	10.29	0.005	0.13	0.032	0.81	0.06	0.027	5370	24000	1800	8000
DPP5W	-	0.3125	7.938	1.2500	31.750	0.745	18.92	0.687	17.45	0.548	13.92	0.015	0.38	0.032	0.81	0.17	0.077	11000	49000	4000	17800
DPP6W	-	0.3750	9.525	1.4375	36.512	0.870	22.10	0.794	20.17	0.610	15.49	0.015	0.38	0.032	0.81	0.26	0.118	15760	70000	5300	23600
DPP8W	-	0.5000	12.700	1.6875	42.862	0.932	23.67	0.856	21.74	0.730	18.54	0.015	0.38	0.044	1.12	0.38	0.172	23600	105000	7800	34700
*DPP10W	-	0.6250	15.875	1.9375	49.212	0.995	25.27	0.920	23.37	0.945	24.00	0.015	0.38	0.044	1.12	0.53	0.240	28400	126000	9400	41800

* Check for availability.

MS27643 • SAE-AS7949

- Double row, ball, self-aligning, heavy duty
- PTFE seals and CRES sealcaps
- Exposed surfaces except bore, caps, and seals are cadmium plated
- Prelubricated for life
- Also offered with CRES 440C material and/or zinc nickel plating per OEM specifications

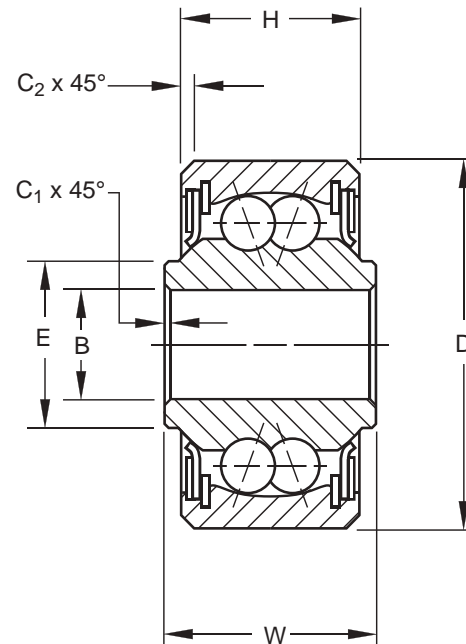
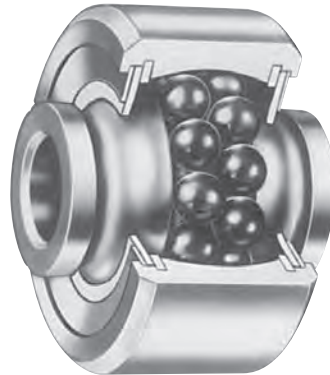

AIRFRAME CONTROL BALL BEARINGS

SPECIFICATIONS AND ORDERING INFORMATION

TO ORDER, SPECIFY BEARING NUMBER AND FACTORY SPECIFICATION. SEE TABLE 1 ON PG 8. (Example DSP3 FS464)

Bearing Number ⁽¹⁾	MS 27643 Dash No.	Bore B		Outside Diameter D		Widths				E		C ₁		C ₂		Wt.		Radial Limit Load Rating		Thrust Limit Load Rating	
		in.	mm	in.	mm	in.	mm	in.	mm	in.	mm	in.	mm	in.	mm	lbs.	kg	lbf.	N	lbf.	N
		+0.0000, -0.0005 +0.000, -0.013		+0.0000, -0.0005 +0.000, -0.013		+0.0000, -0.005 +0.000, -0.13		+0.000, -0.005 +0.00, -0.13		Approx.		+0.015, -0.000 +0.38, -0.00		+0.015, -0.000 +0.38, -0.00		Approx.					
DSP3	-3	0.1900	4.826	0.7774	19.746	0.500	12.70	0.392	9.96	0.304	7.72	0.005	0.13	0.022	0.56	0.04	0.018	1420	6300	200	900
DSP4	-4	0.2500	6.350	0.9014	22.896	0.687	17.45	0.464	11.79	0.430	10.92	0.005	0.13	0.032	0.81	0.06	0.027	1780	7900	300	1340
DSP5	-5	0.3125	7.938	1.2500	31.750	0.812	20.62	0.656	16.66	0.515	13.08	0.015	0.38	0.032	0.81	0.16	0.073	3740	16600	600	2650
DSP6	-6	0.3750	9.525	1.4375	36.512	0.937	23.80	0.750	19.05	0.564	14.33	0.015	0.38	0.032	0.81	0.24	0.109	5100	22700	800	3550
DSP8	-8	0.5000	12.700	1.6875	42.862	1.000	25.40	0.812	20.62	0.775	19.68	0.015	0.38	0.044	1.12	0.36	0.163	7120	31700	1000	4400
DSP10	-10	0.6250	15.875	1.9375	49.212	1.125	28.58	0.937	23.80	0.869	22.07	0.015	0.38	0.044	1.12	0.53	0.240	9000	40000	1300	5800

⁽¹⁾ These bearings are self-aligning for 10° in either direction.

MS27647 • SAE-AS7949 (DW Series)

- Extra wide, double row, ball, medium duty
- PTFE seals and CRES sealcaps
- Exposed surfaces except bore, caps, and seals are cadmium plated
- Prelubricated for life
- Also offered with CRES 440C material and/or zinc nickel plating per OEM specifications

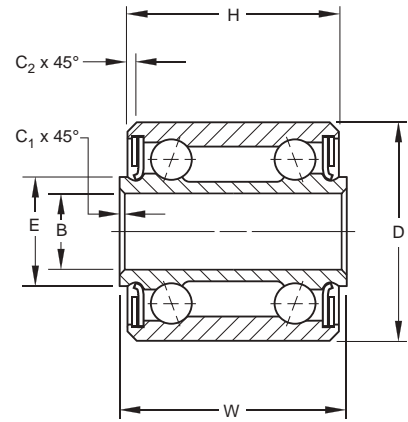

SPECIFICATIONS AND ORDERING INFORMATION

TO ORDER, SPECIFY BEARING NUMBER AND FACTORY SPECIFICATION. SEE TABLE 1 ON PG 8. (Example DW4K2 FS464)

Bearing Number	MS 27647 Dash No.	Bore B		Outside Diameter D		Widths		E	C ₁	C ₂	Wt.		Radial Limit Load Rating		Thrust Limit Load Rating						
		+0.0000, -0.0005 +0.000, -0.013		+0.0000, -0.0005 +0.000, -0.013		+0.000, -0.005 +0.00, -0.13					+0.015, -0.000 +0.38, -0.00		+0.015, -0.000 +0.38, -0.00		Approx.		Approx.				
		in.	mm	in.	mm	in.	mm	in.	mm	in.	mm	in.	mm	lbs.	kg	lbf.	N	lbf.	N		
DW4K2 ⁽¹⁾	-4A	0.2500	6.350	0.6250	15.875	0.562	14.27	0.500	12.70	0.339	8.61	0.005	0.13	0.016	0.41	0.025	0.011	1400	6200	500	2240
DW4K ⁽¹⁾	-4	0.2500	6.350	0.7500	19.050	0.875	22.22	0.750	19.05	0.380	9.65	0.005	0.13	0.016	0.41	0.04	0.018	2770	12200	900	4000
DW4	-	0.2500	6.350	0.7500	19.050	0.875	22.22	0.750	19.05	0.375	9.52	0.005	0.13	0.016	0.41	0.06	0.027	3750	16600	1240	5500
DW5	-5	0.3125	7.938	0.8750	22.225	0.938	23.83	0.813	20.65	0.469	11.91	0.005	0.13	0.016	0.41	0.07	0.032	5140	22800	1600	7100
DW6	-6	0.3750	9.525	1.0625	26.988	1.188	30.18	1.063	27.00	0.573	14.55	0.005	0.13	0.016	0.41	0.12	0.054	8440	37500	2600	11600
DW8	-8	0.5000	12.700	1.4375	36.512	1.500	38.10	1.375	34.92	0.712	18.08	0.005	0.13	0.032	0.81	0.29	0.132	15520	69500	4700	20800

⁽¹⁾ Retainer type.

AIRFRAME CONTROL BALL BEARINGS

MS27647 • SAE-AS7949 (GDW Series)

- Extra wide, double row, ball, medium duty
- PTFE, seals and CRES sealcaps
- Exposed surfaces except bore, caps, and seals are cadmium plated
- Dimensionally interchangeable with the DW series, the GDW series is relubricable through holes and a groove in the outer ring
- Prelubricated for life
- Also offered with CRES 440C material and/or zinc nickel plating per OEM specifications

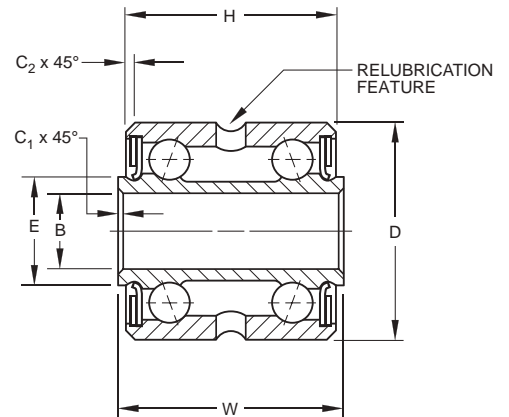

SPECIFICATIONS AND ORDERING INFORMATION

TO ORDER, SPECIFY BEARING NUMBER AND FACTORY SPECIFICATION. SEE TABLE 1 ON PG 8. (Example GDW4K2 FS464)

Bearing Number	MS 27647 Dash No.	Bore B		Outside Diameter D		Widths		E	C ₁	C ₂	Wt.		Radial Limit Load Rating		Thrust Limit Load Rating						
		+0.0000, -0.0005 +0.000, -0.013		+0.0000, -0.0005 +0.000, -0.013		+0.000, -0.005 +0.00, -0.13					+0.015, -0.000 +0.38, -0.00		+0.015, -0.000 +0.38, -0.00		Approx.		Approx.				
		in.	mm	in.	mm	in.	mm	in.	mm	in.	mm	in.	mm	lbs.	kg	lbf.	N	lbf.	N		
GDW4K2 ⁽¹⁾	-4AG	0.2500	6.350	0.6250	15.875	0.562	14.27	0.500	12.70	0.339	8.61	0.005	0.13	0.016	0.41	0.025	0.011	1400	6200	500	2240
GDW4K ⁽¹⁾	-4G	0.2500	6.350	0.7500	19.050	0.875	22.22	0.750	19.05	0.380	9.65	0.005	0.13	0.016	0.41	0.04	0.018	2770	12200	900	4000
GDW4	-	0.2500	6.350	0.7500	19.050	0.875	22.22	0.750	19.05	0.375	9.52	0.005	0.13	0.016	0.41	0.06	0.027	3750	16600	1240	5500
GDW5	-5G	0.3125	7.938	0.8750	22.225	0.938	23.83	0.813	20.65	0.469	11.91	0.005	0.13	0.016	0.41	0.07	0.032	5140	22800	1600	7100
GDW6	-6G	0.3750	9.525	1.0625	26.988	1.188	30.18	1.063	27.00	0.573	14.55	0.005	0.13	0.016	0.41	0.12	0.054	8440	37500	2600	11600
GDW8	-8G	0.5000	12.700	1.4375	36.512	1.500	38.10	1.375	34.92	0.712	18.08	0.005	0.13	0.032	0.81	0.29	0.132	15520	69500	4700	20800

⁽¹⁾ Retainer type.

B5500WZZ Series

- Extra light duty
- Double row, ball
- Torque tube type
- Reinforced Teflon® shields
- Exposed surfaces except bore, and reinforced Teflon® shields are cadmium plated
- Prelubricated for life
- Also offered with CRES 440C material and/or zinc nickel plating per OEM specifications

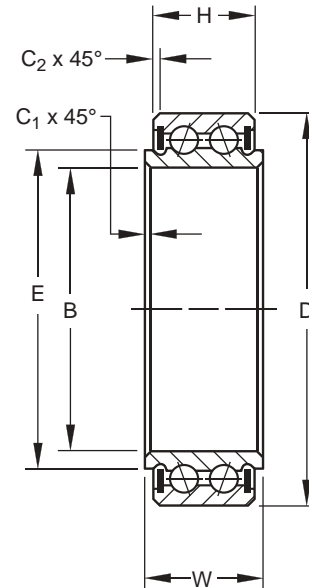

AIRFRAME CONTROL BALL BEARINGS

SPECIFICATIONS AND ORDERING INFORMATION

TO ORDER, SPECIFY BEARING NUMBER AND FACTORY SPECIFICATION. (Example B5538WZZ FS464)

Bearing Number	Bore B		Outside Diameter D		Widths				E		C ₁ ⁽³⁾		C ₂ ⁽³⁾		Wt.		Radial Limit Load Rating		Thrust Limit Load Rating	
	+0.0000, -0.0005 +0.000, -0.013		+0.0000, -0.0005 +0.000, -0.013		+0.000, -0.005 +0.00, -0.13		+0.000, -0.005 +0.00, -0.13		Approx.						Approx.					
	in.	mm	in.	mm	in.	mm	in.	mm	in.	mm	in.	mm	in.	mm	lbs.	kg	lbf.	N	lbf.	N
B5538WZZ	0.6250	15.875	1.0625	26.988	0.562	14.27	0.500	12.70	0.745	18.92	0.015	0.38	0.015	0.38	0.04	0.018	6250	28000	2060	9150
B5539WZZ	0.7500	19.050	1.1875	30.162	0.562	14.27	0.500	12.70	0.865	21.97	0.015	0.38	0.015	0.38	0.06	0.027	7190	32000	2370	10600
B5540WZZ	0.8750	22.225	1.3125	33.338	0.562	14.27	0.500	12.70	0.989	25.12	0.015	0.38	0.015	0.38	0.08	0.036	8120	36000	2680	12000
B5541WZZ	1.0625	26.988	1.5000	38.100	0.562	14.27	0.500	12.70	1.190	30.23	0.015	0.38	0.015	0.38	0.10	0.045	9690	43000	3200	14300
B5542WZZ	1.3125	33.338	1.7500	44.450	0.562	14.27	0.500	12.70	1.430	36.32	0.015	0.38	0.015	0.38	0.14	0.064	11600	52000	3820	17000
B5543WZZ	1.5625	39.688	2.0000	50.800	0.562	14.27	0.500	12.70	1.665	42.29	0.015	0.38	0.015	0.38	0.16	0.073	13400	60000	4430	19700
B5544WZZ	1.8125 ⁽¹⁾	46.038 ⁽¹⁾	2.2500 ⁽²⁾	57.150 ⁽²⁾	0.562	14.27	0.500	12.70	1.935	49.15	0.015	0.38	0.015	0.38	0.18	0.082	15600	69500	5160	23000
B5545WZZ	2.0625 ⁽¹⁾	52.388 ⁽¹⁾	2.6250 ⁽²⁾	66.675 ⁽²⁾	0.562	14.27	0.500	12.70	2.265	57.53	0.015	0.38	0.015	0.38	0.26	0.118	18100	80500	5980	26600
*B5546WZZ	2.3125 ⁽¹⁾	58.738 ⁽¹⁾	2.8750 ⁽²⁾	73.025 ⁽²⁾	0.562	14.27	0.500	12.70	2.505	63.63	0.015	0.38	0.015	0.38	0.30	0.136	20000	89000	6600	29400

⁽¹⁾ +0.0000 in. (+0.000mm), -0.0008 in. (-0.020mm).

⁽²⁾ +0.0000 in. (+0.000mm), -0.0007 in. (-0.018mm).

⁽³⁾ Maximum shaft or housing fillet radius which bearing corners will clear.

* Check for availability.

D Series

- Double row, ball
- PTFE seals and CRES sealcaps
- Exposed surfaces except bore, caps, and seals are cadmium plated
- Prelubricated for life with MIL-PRF-23827 Type 1 grease

AIRFRAME CONTROL BALL BEARINGS

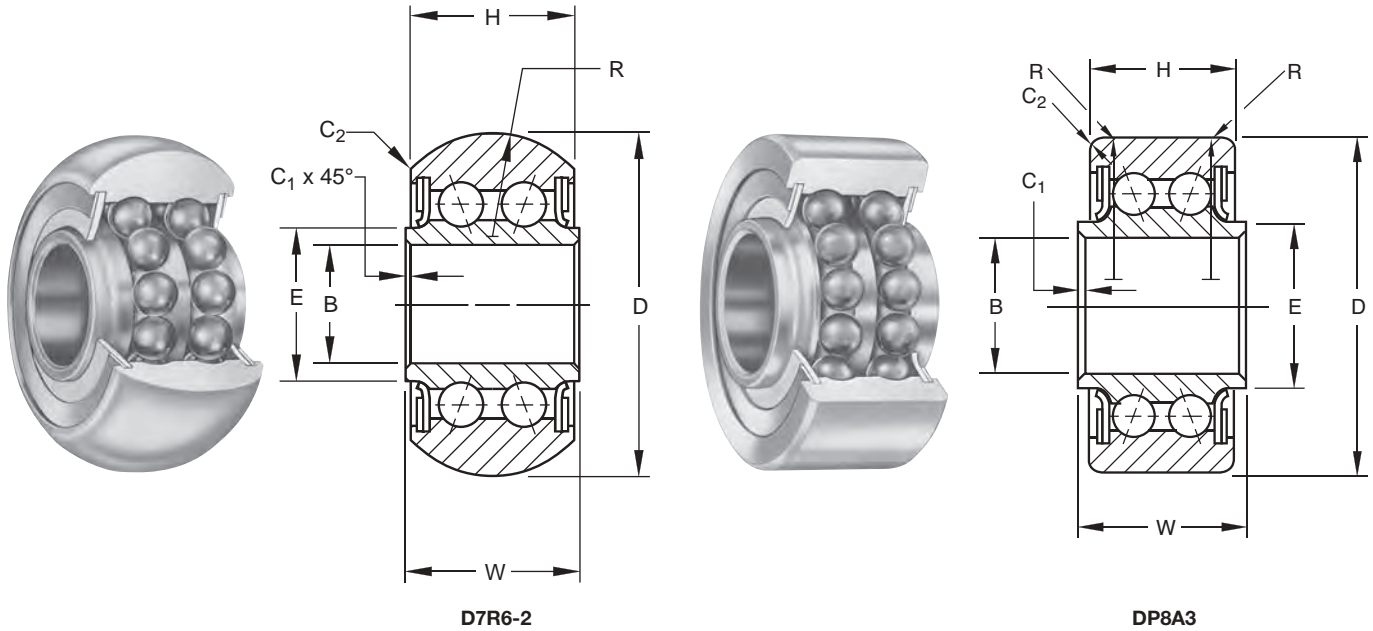

SPECIFICATIONS AND ORDERING INFORMATION

TO ORDER, SPECIFY BEARING NUMBER AND FACTORY SPECIFICATION PER BELOW. (Example D7R6-2 FS160)

Bearing Number	Bore B		Outside Diameter D		Widths				E	C ₁		C ₂		R	Max. Safe Working Load Radial ⁽¹⁾		Wt.			
	+0.0000, -0.0005 +0.000, -0.013				+0.000, -0.005 +0.00, -0.13		+0.000, -0.005 +0.00, -0.13			Approx.	+0.015-0.000 +0.38, -0.00		(Ref.)				Approx.			
	in.	mm	in.	mm	in.	mm	in.	mm	in.		mm	in.	mm	in.	mm	lb.	N	lbs.	kg	
D7R6-2 FS160	0.4375	11.112	1.250	31.75	0.625	15.88	0.600	15.24	0.566	14.38	0.005 ⁽²⁾	0.13 ⁽²⁾	0.05	1.27	0.375	9.52	1000	4400	0.12	.055
			1.240	31.50			0.590	14.99							0.365	9.27				
DP8A3 FS160	0.5000	12.70	1.225	31.12	0.625	15.88	0.527	13.39	0.610	15.49	0.005 ⁽²⁾	0.13 ⁽²⁾	.050	1.27	.515 ⁽³⁾	13.08	1000	4400	0.11	0.050
			1.220	30.99											.030	0.76				

⁽¹⁾ The maximum working radial load to obtain 100,000 ft. (30,500m) peripheral travel life.

⁽²⁾ +.010 in. (+.25mm) -.000 in. (-.00mm).

⁽³⁾ Centerline of radius located .090 in. (2.29mm) to .120 in. (3.05mm) from faces of outer ring.

* Check for availability.

G Series

- Single and double row
- Equipped with molded rubber seals or CRES shields
- Exposed surfaces except bore, caps, and seals are cadmium plated
- Prelubricated for life

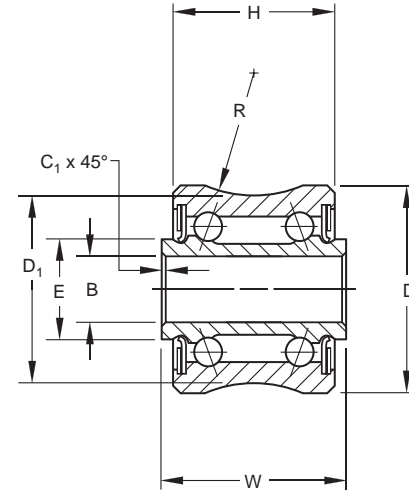

SPECIFICATIONS AND ORDERING INFORMATION

TO ORDER, SPECIFY BEARING NUMBER AND FACTORY SPECIFICATION PER BELOW. (Example GD5M28 FS160)

Bearing Number	Bore B		Outside Diameter D		Widths		E	C ₁		D ₁	R	Max. Safe Working Load Radial ⁽¹⁾	Wt.							
	in.	mm	in.	mm	W	H		in.	mm					in.	mm	lbs.	N	lbs.	kg	
*GD5M28 FS160	0.3125	7.938	1.015	25.78	0.9375	23.81	0.812	20.62	0.472	11.99	0.005	0.13	0.901	22.89	0.895	22.73	600	2650	0.10	0.045
	0.3120	7.925											0.900	22.86	0.905	22.99				

⁽¹⁾ The maximum safe working load is that radial load to obtain 100,000 ft. (30,500 M) peripheral travel life.

AIRFRAME CONTROL BALL BEARINGS

BCP Series

- Double row, ball
- Equipped with molded rubber seals
- Exposed surfaces except bore, caps, and seals are cadmium plated
- Prepacked with lubricant conforming to MIL-PRF-23827, Type 1

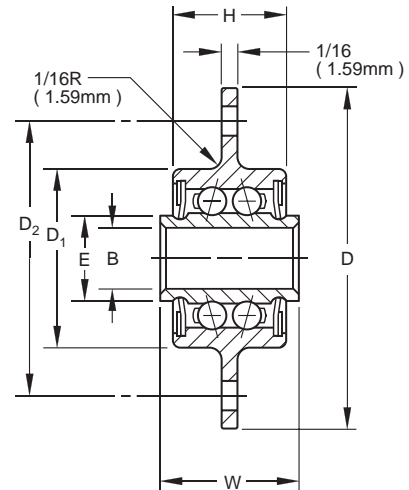

SPECIFICATIONS AND ORDERING INFORMATION

TO ORDER, SPECIFY BEARING NUMBER AND FACTORY SPECIFICATION PER BELOW. (Example BCP4W10 FS302)

Bearing Number ⁽¹⁾	Bore B		Outside Diameter D		Widths		E	D ₁	D ₂	Wt.	Radial Limit Load Rating	Thrust Limit Load Rating								
	in.	mm	in.	mm	W	H							in.	mm	in.	mm	lbs.	kg	lbs.	N
BCP4W10 FS302	0.25	6.350	1.625	41.28	0.625	15.88	0.500	12.70	0.404	10.26	0.750	19.05	1.312	33.32	0.06	0.027	2770	12300	700	3100
BCP5W11 FS302	0.3125	7.938	1.687	42.85	0.687	17.45	0.562	14.27	0.453	11.51	0.875	22.22	1.375	34.92	0.08	0.036	3280	14600	900	4000

⁽¹⁾ Both sizes are furnished with 12 equally spaced holes in the flange. Holes are .140 in. (+.005, -.000) in diameter.

MDPP Precision Series

- Double row, ball, light and heavy duty
- PTFE seals and CRES sealcaps
- Exposed surfaces except bore, caps and seals are cadmium plated
- Prelubricated for life
- Also offered with CRES 440C material and/or zinc nickel plating per OEM specifications

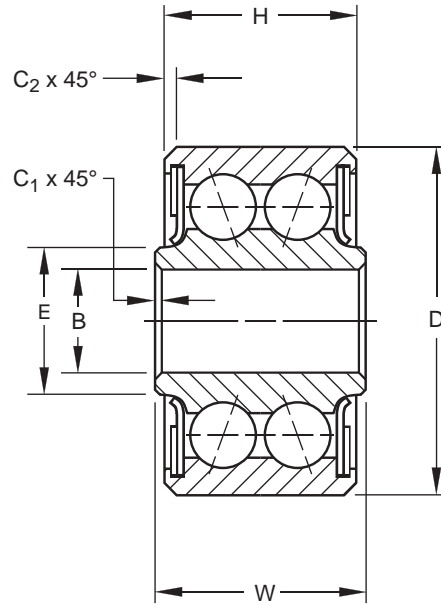

AIRFRAME CONTROL BALL BEARINGS

SPECIFICATIONS AND ORDERING INFORMATION

TO ORDER, SPECIFY BEARING NUMBER AND FACTORY SPECIFICATION. (Example MDPP3 FS464)

Bearing Number	Bore B		Outside Diameter D		Widths W		H	E		C ₁		C ₂		Wt.		Radial Limit Load Rating	Thrust Limit Load Rating				
	in.	mm	in.	mm	in.	mm		in.	mm	in.	mm	in.	mm	lbs.	kg						
	+0.0000, -0.0003 +0.000, -0.008		+0.0000, -0.0004 +0.000, -0.010		+0.0000, -0.0025 +0.000, -0.064		+0.000, -0.005 +0.00, -0.13		Approx.		+0.015-0.000 +0.38-0.00		+0.015-0.000 +0.38-0.00		Approx.						
*MDPP3	—	0.1900	4.826	0.7774	19.746	0.4950	12.570	0.473	12.01	0.302	7.67	0.005	0.13	0.018	0.46	0.04	0.018	2950	13200	1700	7500
MDPP4	—	0.2500	6.350	0.9014	22.896	0.6200	15.750	0.491	12.47	0.410	10.41	0.005	0.13	0.032	0.81	0.06	0.027	5370	24000	1800	8000
MDPP5	—	0.3125	7.938	1.2500	31.750	0.7450	18.920	0.687	17.45	0.469	11.91	0.015	0.38	0.032	0.81	0.17	0.077	11000	49000	4000	17800
*MDPP6	—	0.3750	9.525	1.4375	36.512	0.8700	22.100	0.794	20.17	0.551	14.00	0.015	0.38	0.032	0.81	0.26	0.118	15760	70000	5300	23600
*MDPP8	—	0.5000	12.700	1.6875	42.862	0.9320	23.670	0.856	21.74	0.735	18.67	0.015	0.38	0.044	1.12	0.38	0.172	23600	105000	7800	34700
*MDPP10	—	0.6250	15.875	1.9375	49.212	0.9950	25.270	0.920	23.37	0.890	22.61	0.015	0.38	0.044	1.12	0.53	0.240	28400	126000	9400	41800

* Check for availability.

MS27643-R • SAE-AS7949

- Double row, ball, self-aligning, heavy duty
- PTFE seals and CRES sealcaps
- Exposed surfaces except bore, caps, and seals are cadmium plated
- Prelubricated for life
- Also offered with CRES 440C material and/or zinc nickel plating per OEM specifications

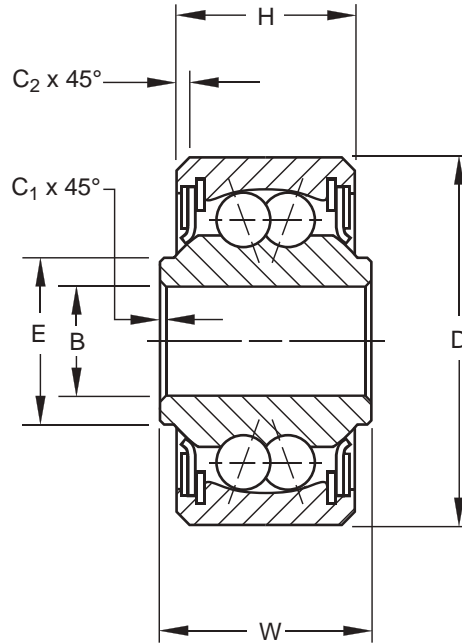
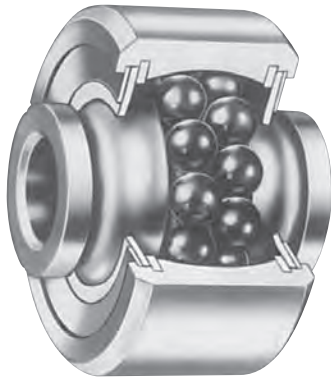

AIRFRAME CONTROL BALL BEARINGS

SPECIFICATIONS AND ORDERING INFORMATION

TO ORDER, SPECIFY BEARING NUMBER AND FACTORY SPECIFICATION. SEE TABLE 1 ON PG 8. (Example MDSP3 FS464)

Bearing Number	MS 27643 Dash No.	Bore B		Outside Diameter D		Widths				E		C ₁		C ₂		Wt.		Radial Limit Load Rating		Thrust Limit Load Rating	
		in.	mm	in.	mm	in.	mm	in.	mm	in.	mm	in.	mm	in.	mm	lbs.	kg	lbf.	N	lbf.	N
		+0.0000, -0.0003 +0.000, -0.008		+0.0000, -0.0004 +0.000, -0.010		+0.0000, -0.0025 +0.000, -0.064		+0.000, -0.005 +0.00, -0.13		Approx.		+0.015-0.000 +0.38-0.00		+0.015-0.000 +0.38-0.00		Approx.					
MDSP3 ⁽¹⁾	-3R	0.1900	4.826	0.7774	19.746	0.5000	12.700	0.392	9.96	0.304	7.72	0.005	0.13	0.022	0.56	0.04	0.018	1420	6300	200	900
MDSP4 ⁽¹⁾	-4R	0.2500	6.350	0.9014	22.896	0.6870	17.450	0.464	11.79	0.430	10.92	0.005	0.13	0.032	0.81	0.06	0.027	1780	7900	300	1340
MDSP5 ⁽¹⁾	-5R	0.3125	7.938	1.2500	31.750	0.8120	20.620	0.656	16.66	0.515	13.08	0.015	0.38	0.032	0.81	0.16	0.073	3740	16600	600	2650
MDSP6 ⁽¹⁾	-6R	0.3750	9.525	1.4375	36.512	0.9370	23.800	0.750	19.05	0.564	14.33	0.015	0.38	0.032	0.81	0.24	0.109	5100	22700	800	3550
*MDSP8 ⁽¹⁾	-8R	0.5000	12.700	1.6875	42.862	1.0000	25.400	0.812	20.62	0.775	19.68	0.015	0.38	0.044	1.12	0.36	0.163	7120	31700	1000	4400
*MDSP10 ⁽¹⁾	-10R	0.6250	15.875	1.9375	49.212	1.1250	28.580	0.937	23.80	0.869	22.07	0.015	0.38	0.044	1.12	0.53	0.240	9000	40000	1300	5800

⁽¹⁾ These bearings are self-aligning for 10° in either direction

* Check for availability.

MS27647-R • SAE-AS7949

- Extra wide, double row, ball, medium duty
- PTFE seals and CRES sealcaps
- Exposed surfaces except bore, caps, and seals are cadmium plated
- Prelubricated for life
- Also offered with CRES 440C material and/or zinc nickel plating per OEM specifications

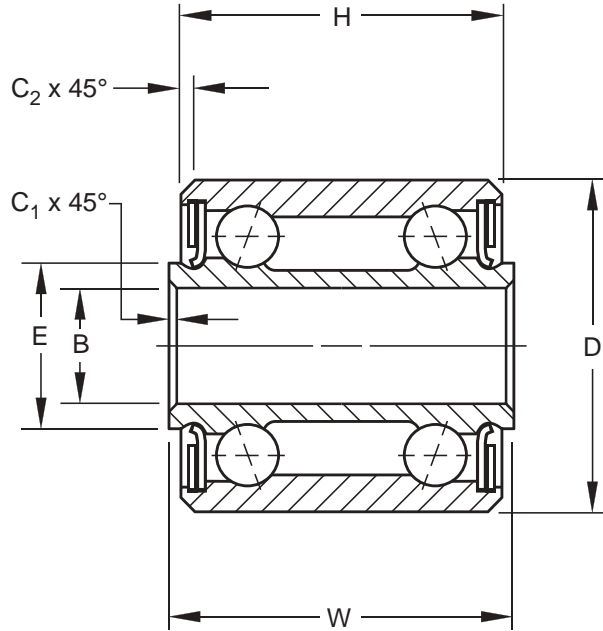
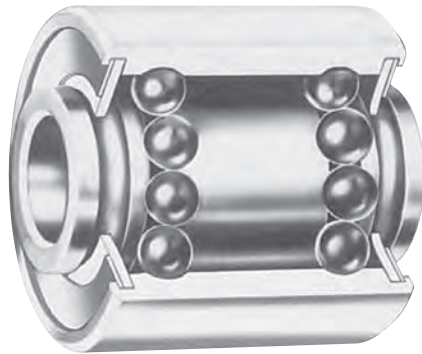

AIRFRAME CONTROL BALL BEARINGS

SPECIFICATIONS AND ORDERING INFORMATION

TO ORDER, SPECIFY BEARING NUMBER AND FACTORY SPECIFICATION. SEE TABLE 1 ON PG 8. (Example MDW4K2 FS464)

Bearing Number	MS 27647 Dash No.	Bore B		Outside Diameter D		Widths W		H	E		C ₁	C ₂	Wt.	Radial Limit Load Rating	Thrust Limit Load Rating						
		in.	mm	in.	mm	in.	mm		in.	mm						in.	mm	lbs.	kg	lb.	N
		+0.0000, -0.0003 +0.000, -0.008		+0.0000, -0.0004 +0.000, -0.010		+0.0000, -0.0025 +0.000, -0.064	+0.000, -0.005 +0.00, -0.13		Approx.		+0.015-0.000 +0.38-0.00	+0.015-0.000 +0.38-0.00	Approx.								
MDW4K2 ⁽¹⁾	-4AR	0.2500	6.350	0.6250	15.875	0.5620	14.275	0.500	12.70	0.339	8.61	0.005	0.13	0.016	0.41	0.025	0.011	1400	6200	500	2240
*MDW4K ⁽¹⁾	-4R	0.2500	6.350	0.7500	19.050	0.8750	22.225	0.750	19.05	0.380	9.65	0.005	0.13	0.016	0.41	0.04	0.018	2770	12200	900	4000
*MDW4	—	0.2500	6.350	0.7500	19.050	0.8750	22.225	0.750	19.05	0.375	9.52	0.005	0.13	0.016	0.41	0.06	0.027	3750	16600	1240	5500
MDW5	-5R	0.3125	7.938	0.8750	22.225	0.9380	23.825	0.813	20.65	0.469	11.91	0.005	0.13	0.016	0.41	0.07	0.032	5140	22800	1600	7100
MDW6	-6R	0.3750	9.525	1.0625	26.988	1.1880	30.175	1.063	27.00	0.573	14.55	0.005	0.13	0.016	0.41	0.12	0.054	8440	37500	2600	11600
MDW8	-8R	0.5000	12.700	1.4375	36.512	1.5000	38.100	1.375	34.92	0.712	18.08	0.005	0.13	0.032	0.81	0.29	0.132	15520	69500	4700	20800

⁽¹⁾ Retainer type.
* Check for availability.

RBC Airframe Control Roller Bearings

PRODUCT NOMENCLATURE	56	PRODUCT NOMENCLATURE	56
SINGLE ROW SELF ALIGNING CONVEX ROLLER BEARINGS		DOUBLE ROW SELF ALIGNING CONCAVE ROLLER BEARINGS	
DSRP, GDSRP Series		HGS Series	
Single Row Self Aligning , Heavy Duty	57	Double Row Self Aligning Heavy Duty	58–59

GENERAL FEATURES AND TECHNICAL SPECIFICATIONS

Swage Groove

Swage grooves are a standard feature on concave roller bearings that allows easy installation into the application.

Self-Aligning

Ring misalignment allows flexible installation

Roller

Concave or convex roller bearings are available from RBC for maximum design flexibility.

Caps and Seals

Bearings are sealed for lube retention and contaminant prevention. Slits are designed in the seals for the purging of used grease on concave roller bearings. Seals are made from thermoplastic polyester elastomer held in place with corrosion resistant caps.

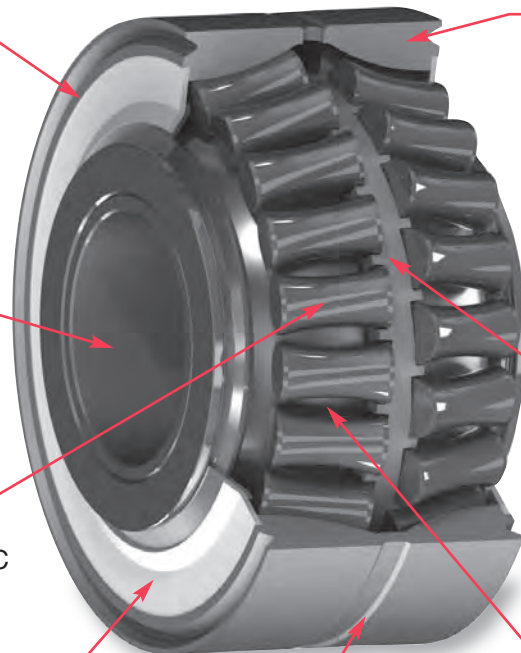

Ring Material

Rings are made from thru-hardened 52100, CREN, or CRES materials to accommodate the applications need. The external surfaces are passivated or plated with cadmium or zinc-nickel to provide protection from galvanic corrosion.

Retainer

Retainers are made from a copper nickel tin alloy. They are an optimized design to prolong the life of the rolling elements (concave roller bearings only).

Lubrication

Bearings are 80% to 100% filled with grease in compliance to OEM's specification.

Relubrication Groove

In-service relubrication without disassembly through the outer ring is offered. In-service relubrication allows for a longer service life than factory sealed bearings.

AIRFRAME CONTROL ROLLER BEARINGS

AIRFRAME CONTROL ROLLER BEARINGS

CONVEX ROLLER BEARINGS

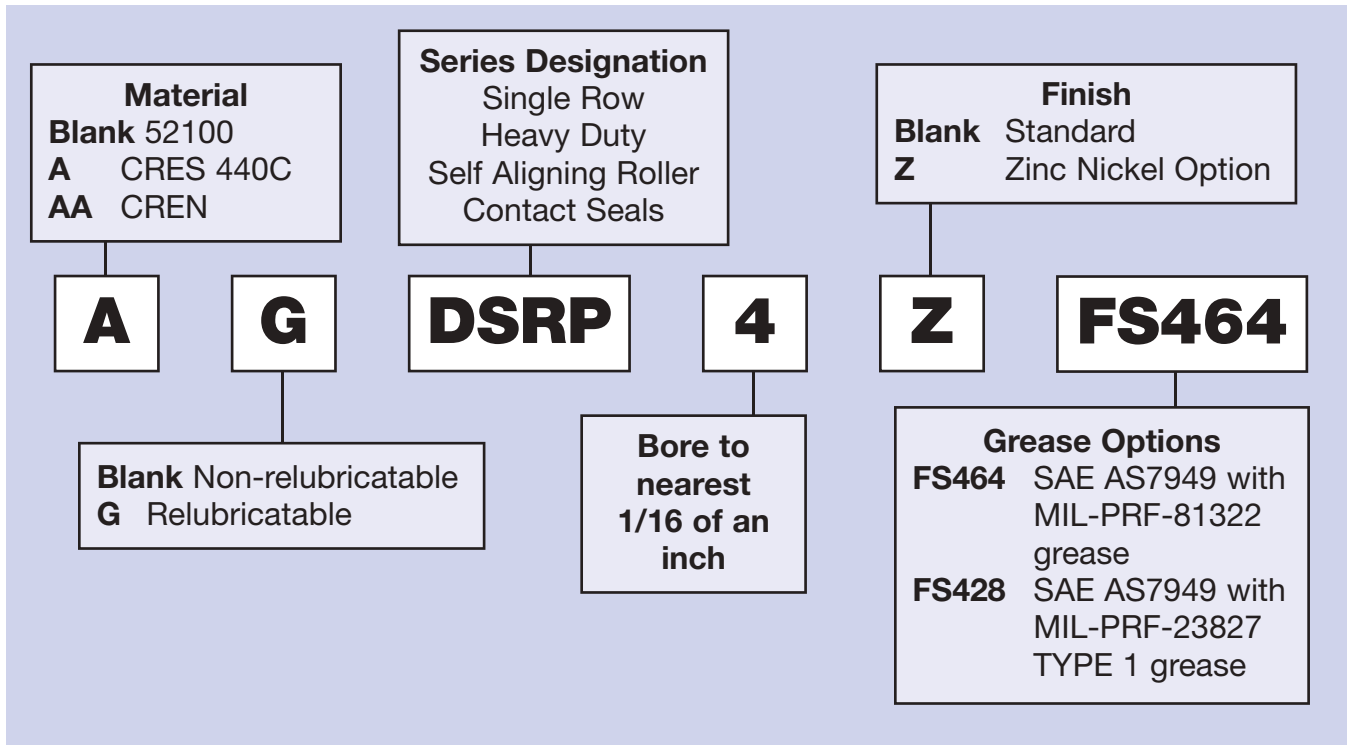

AIRFRAME CONTROL ROLLER BEARINGS

CONCAVE ROLLER BEARINGS

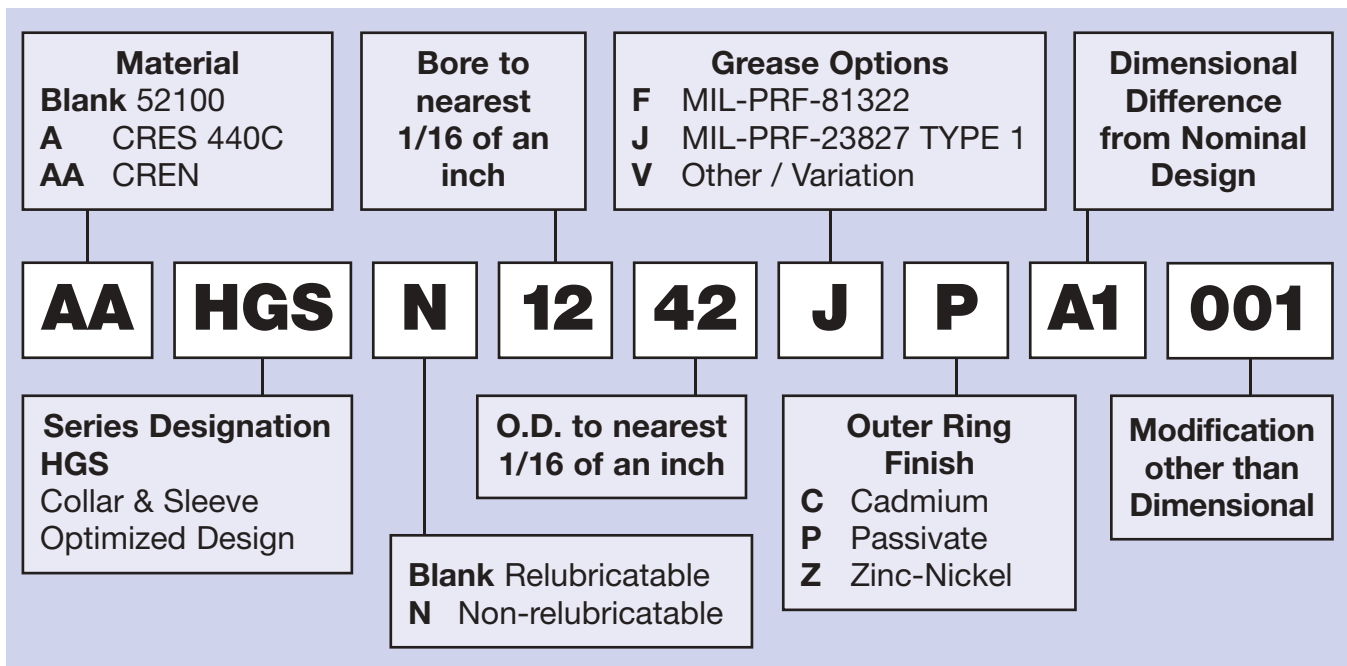

DSRP, GDSRP Series

- Self-aligning convex roller, heavy duty
- Exposed surfaces except bore, caps, and seals are cadmium plated
- Prelubricated for life
- The DSRP series is dimensionally interchangeable with the DSP series except the DSRP4 inner ring width and shoulder

- PTFE seals and CRES caps
- The GDSRP series is dimensionally interchangeable with the DSRP series; however, it is relubricable through grooves and holes drilled outside of the bearing load zone, which permits access of lubricant to rollers and raceways
- Also offered with CRES 440C material and/or zinc nickel plating per OEM specifications

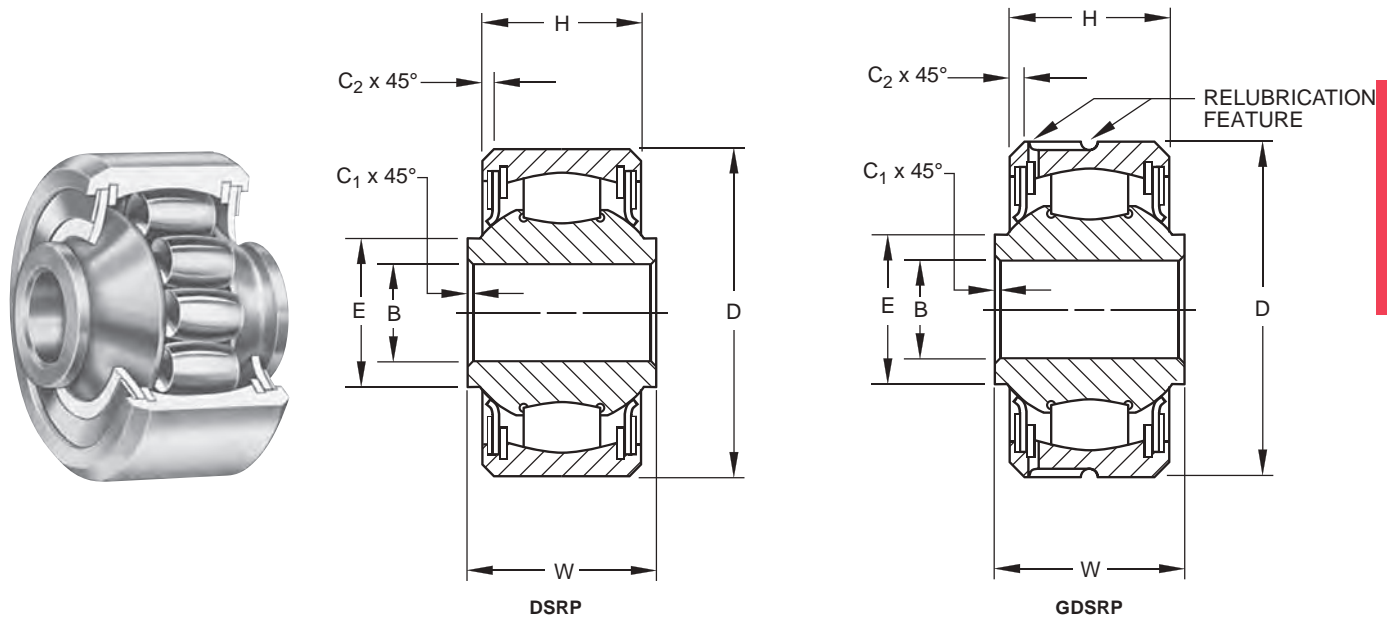

AIRFRAME CONTROL ROLLER BEARINGS

SPECIFICATIONS AND ORDERING INFORMATION

TO ORDER, SPECIFY BEARING NUMBER AND FACTORY SPECIFICATION. (Example DSRP4 FS464)

Bearing Number ⁽¹⁾	Bore B	Outside Diameter D		Widths		E	C ₁		C ₂		Wt.	Radial Limit Load Rating ⁽¹⁾	Thrust Limit Load Rating
		W	H	W	H		in.	mm	in.	mm			
DSRP Series		+0.0000, -0.0005	+0.0000, -0.0005	+0.000, -0.005	+0.000, -0.005	Approx.	+0.015, -0.000	+0.015, -0.000	Approx.				
		+0.000, -0.013	+0.000, -0.013	+0.00, -0.13	+0.00, -0.13		+0.38, -0.00	+0.38, -0.00					
		in. mm	in. mm	in. mm	in. mm	in. mm	in. mm	in. mm	in. mm	lbs. kg	lbf. N	lbf. N	
DSRP4	GDSRP4	0.2500 6.350	0.9014 22.896	0.625 15.88	0.464 11.78	0.404 10.26	0.005 0.13	0.032 0.81	0.06 0.027	3025 13400	908 4040		
DSRP5	GDSRP5	0.3125 7.938	1.2500 31.750	0.812 20.62	0.656 16.66	0.515 13.08	0.015 0.38	0.032 0.81	0.16 0.073	7350 32700	2200 9800		
DSRP6	GDSRP6	0.3750 9.525	1.4375 36.512	0.937 23.80	0.750 19.05	0.564 14.33	0.015 0.38	0.032 0.81	0.24 0.109	9600 42700	2880 12800		
DSRP8	GDSRP8	0.5000 12.700	1.6875 42.862	1.000 25.40	0.812 20.62	0.775 19.68	0.015 0.38	0.044 1.12	0.36 0.163	12500 55600	3750 16700		
*DSRP10	GDSRP10⁽²⁾	0.6250 15.875	1.9375 49.212	1.125 28.58	0.937 23.80	0.869 22.07	0.015 0.38	0.044 1.12	0.55 0.249	17700 78700	5310 23600		
*DSRP12	GDSRP12⁽²⁾	0.7500 19.050	2.3750 60.325	1.312 33.32	1.125 28.58	1.150 29.21	0.015 0.38	0.044 1.12	1.05 0.476	26900 120000	8070 35900		

⁽¹⁾ These bearings are self-aligning for 10° in either direction.

⁽²⁾ Will be made as demand justifies tooling.

* Check for availability.

AIRFRAME CONTROL ROLLER BEARINGS — HGS DOUBLE ROW SERIES SELF-ALIGNING CONCAVE ROLLER



HGS Series

- Heavy duty self-aligning concave rollers
- High radial and axial load ratings
- Low torque
- Low initial free play with minimal wear over life of bearing
- Even wear and false brinell resistance
- Hytrel seals and CRES caps, collars & sleeves

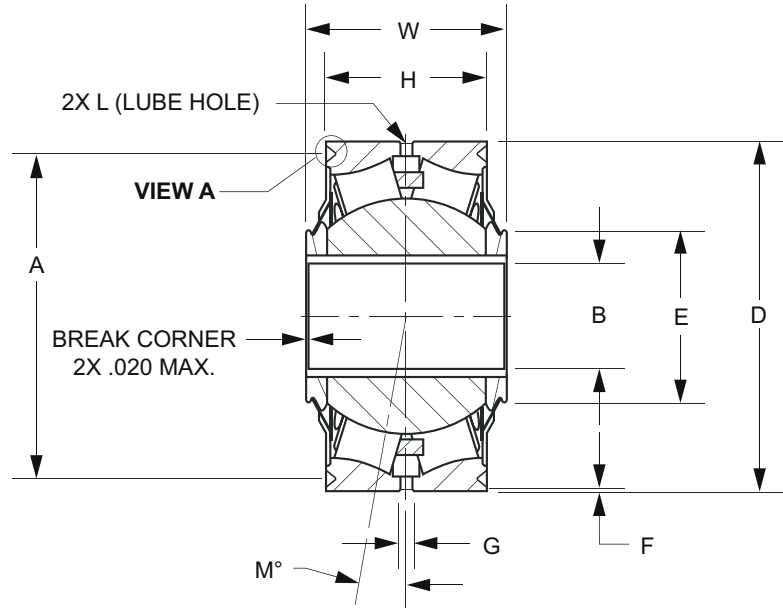

SPECIFICATIONS AND ORDERING INFORMATION

TO ORDER, SPECIFY BEARING NUMBER (EXAMPLE: AAHGS0828JP).

Base Bearing Number	Bore B		Outside Diameter D		Widths				E		F		G		L	
	+0.0000, -0.0005 +0.000, -0.013		+0.0000, -0.0005 +0.000, -0.013		+0.0000, -0.005 +0.000, -0.13		+0.000, -0.005 +0.00, -0.13		Ref.		+0.005, -0.005 +0.13, -0.13		Min.		+0.010, -0.010 +0.25, -0.25	
	in.	mm	in.	mm	in.	mm	in.	mm	in.	mm	in.	mm	in.	mm	in.	mm
HGS04-16	0.2500	6.350	1.0000	25.400	0.625	15.88	0.464	11.79	0.450	11.43	0.015	0.381	0.080	2.03	0.060	1.52
HGS05-20	0.3125	7.938	1.2500	31.750	0.812	20.62	0.656	16.66	0.520	13.208	0.015	0.381	0.080	2.03	0.060	1.52
HGS05-20 A1	0.3125	7.938	1.2500	31.750	0.812	20.62	0.656	16.66	0.520	13.208	0.015	0.381	0.080	2.03	0.060	1.52
HGS06-23	0.3750	9.525	1.4375	36.513	0.937	23.80	0.750	19.05	0.610	15.494	0.015	0.381	0.080	2.03	0.060	1.52
HGS06-24	0.3750	9.525	1.5000	38.100	0.937	23.80	0.750	19.05	0.610	15.494	0.015	0.381	0.080	2.03	0.060	1.52
HGS07-25	0.4375	11.113	1.5625	39.688	1.187	30.15	0.844	21.44	0.670	17.018	0.015	0.381	0.080	2.03	0.060	1.52
HGS08-28	0.5000	12.700	1.7500	44.450	1.000	25.40	0.812	20.62	0.820	20.828	0.015	0.381	0.080	2.03	0.060	1.52
HGSN08-28 A1	0.5000	12.700	1.7500	44.450	1.500	38.10	0.812	20.62	0.820	20.828	(2)	(2)	(2)	(2)	(2)	(2)
HGS10-31	0.6250	15.875	1.9375	49.213	1.125	28.58	0.937	23.80	0.940	23.876	0.015	0.381	0.080	2.03	0.060	1.52
HGSN10-31 A1	0.6250	15.875	1.9375	49.213	1.000	25.40	0.812	20.62	0.820	20.828	(2)	(2)	(2)	(2)	(2)	(2)
HGS12-31	0.7500	19.050	1.9375	49.213	1.000	25.40	0.969	24.61	1.015	25.781	0.015	0.381	0.080	2.03	0.060	1.52
HGS12-42	0.7500	19.050	2.6250	66.675 ⁽¹⁾	1.875	47.63	1.250	31.75	1.230	31.242	0.015	0.381	0.100	2.54	0.090	2.29
HGS14-48	0.8750	22.225	3.0000	76.200 ⁽¹⁾	2.000	50.80	1.500	38.10	1.350	34.29	0.015	0.381	0.100	2.54	0.090	2.29
HGS16-40	1.0000	25.400	2.5000	63.500 ⁽¹⁾	1.375	34.93	1.125	28.58	1.335	33.909	0.015	0.381	0.100	2.54	0.090	2.29
HGS18-42	1.1250	28.575	2.6250	66.675 ⁽¹⁾	1.375	34.93	1.190	30.23	1.575	40.005	0.015	0.381	0.100	2.54	0.090	2.29

⁽¹⁾ +0.0000, -0.0007 in.; +0.000, -0.018mm.

⁽²⁾ These are non relubricatable designs, these dimensions are not used.

- Relubricatable and non-relubricatable designs available
- Integral swage grooves available
- Up to 10 degrees misalignment capability
- Passivated (AMS 2700), zinc-nickel (AMS 2417) or cadmium plate (AMS-QQ-P-416) available on exposed surfaces
- Standard materials; 52100, 9310, and 440C
- Special ring and roller materials available:
 - Pyrowear® (AMS 5930) CREN for swaged outer rings
 - Cronidur 30® (AMS 5898) CREN for inner rings and rollers
 - XD15NW (AMS 5925) CREN for rings and rollers

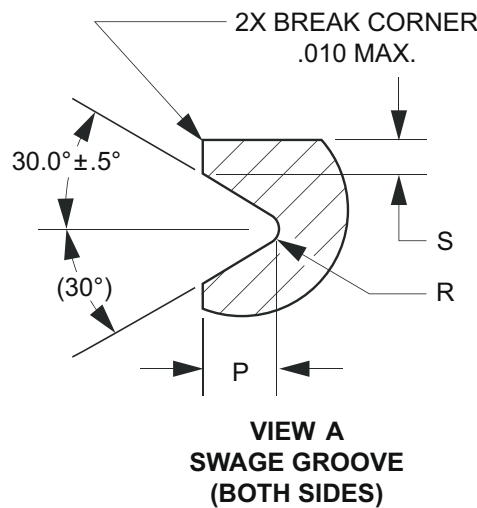

**AIRFRAME CONTROL
ROLLER BEARINGS**

SPECIFICATIONS AND ORDERING INFORMATION

TO ORDER, SPECIFY BEARING NUMBER (EXAMPLE: AAHGS0828JP).

Base Bearing Number	M° Min.	Swage Groove				Load Ratings		Wt.							
		A Ref.	P +0.0000, -0.0005 +0.000, -0.013	R +0.0000, -0.0005 +0.000, -0.013	S +0.0000, -0.0025 +0.000, -0.064	Radial Limit Load Rating	Thrust Limit Load Rating	Ref.	Ref.						
										in.	mm	in.	mm	in.	mm
HGS04-16	10	0.896	22.76	0.040	1.02	0.015	0.381	0.03	0.762	3960	17600	2180	9700	0.08	0.04
HGS05-20	10	1.145	29.08	0.040	1.02	0.015	0.381	0.03	0.762	8980	39950	5100	22700	0.18	0.08
HGS05-20 A1	10	1.185	30.10	0.030	0.76	0.010	0.254	0.02	0.508	8980	39950	5100	22700	0.18	0.08
HGS06-23	10	1.333	33.86	0.040	1.02	0.015	0.381	0.03	0.762	12000	53400	6880	30600	0.27	0.12
HGS06-24	10	1.372	34.85	0.060	1.52	0.015	0.381	0.03	0.762	12000	53400	6880	30600	0.27	0.12
HGS07-25	10	1.436	36.47	0.060	1.52	0.015	0.381	0.03	0.762	14500	64500	8330	37050	0.36	0.16
HGS08-28	10	1.622	41.20	0.060	1.52	0.015	0.381	0.03	0.762	16000	71150	8520	37900	0.42	0.19
HGSN08-28 A1	10	1.622	41.20	0.060	1.52	0.015	0.381	0.03	0.762	16000	71150	8520	37900	0.42	0.19
HGS10-31	10	1.809	45.95	0.060	1.52	0.015	0.381	0.03	0.762	27100	120550	13900	61850	0.59	0.27
HGSN10-31 A1	10	1.809	45.95	0.060	1.52	0.015	0.381	0.03	0.762	16000	71150	8520	37900	0.59	0.27
HGS12-31	4	1.809	45.95	0.060	1.52	0.015	0.381	0.03	0.762	27100	120550	13900	61850	0.56	0.25
HGS12-42	10	2.497	63.42	0.060	1.52	0.015	0.381	0.03	0.762	44800	199300	21700	96550	1.58	0.72
HGS14-48	10	2.872	72.95	0.060	1.52	0.015	0.381	0.03	0.762	64100	285150	32000	142350	2.36	1.07
HGS16-40	3	2.372	60.25	0.060	1.52	0.015	0.381	0.03	0.762	45500	202400	20400	90750	1.16	0.53
HGS18-42	2	2.497	63.42	0.060	1.52	0.015	0.381	0.03	0.762	54100	240650	21500	95650	1.36	0.62

RBC Ball Bearing Rod Ends

PRODUCT NOMENCLATURE	61
BALL BEARING ROD ENDS	
External Threaded Series	
MS21151 REP-M Series: External Threaded	62
AeroCres® Fracture-tough Airframe Products	63-64
Internal Threaded Series	
MS21153 REP-F Series: Internal Threaded	65
Hollow Shank Series	
MS21152 REP-H Series: Hollow Shank	66

Solid Shank Series	
MS21150 REP-S Series: Solid Shank	66
ROLLER ROD ENDS	
RA/RR External Threaded Series	
NAS-659 RA-M/RR-M Series: External Series	67
RA/RR Hollow Shank Series	
NAS-660 RA-H/RR-H Series: Hollow Shank	68

GENERAL FEATURES AND TECHNICAL SPECIFICATIONS

BALL BEARING
ROD ENDS

Outer Rod End Body

The rod end body is selectively heat treated to provide a combination of a fracture tough head, ductile shank, and a carburized raceway to provide high load carrying capacity. External surfaces are plated with Cadmium to provide corrosion protection and thread lubricity. The rod end body can be supplied with AISI8620 or RBC's proprietary "Aerocres" corrosion resistant material.

Seals and Caps

These bearings are equipped with PTFE seals bonded to corrosion resistance caps.

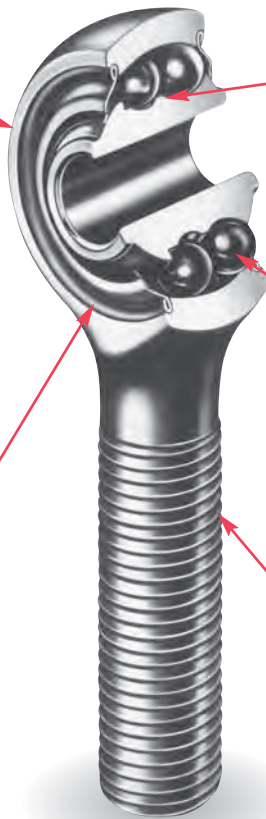

Lubrication

Bearings are 80 to 100% filled with greases in compliance with MIL-PRF-81322, MIL-PRF-23827 Type 1, and Boeing's BMS3-33.

Inner Ring and Balls

Rings and balls are made from thru-hardened 52100 or CRES 440C to accommodate the application's corrosion resistance needs.

Construction

These double row, self aligning bearings accommodate the application's low torque, high load, and misalignment needs.

BALL BEARING ROD ENDS

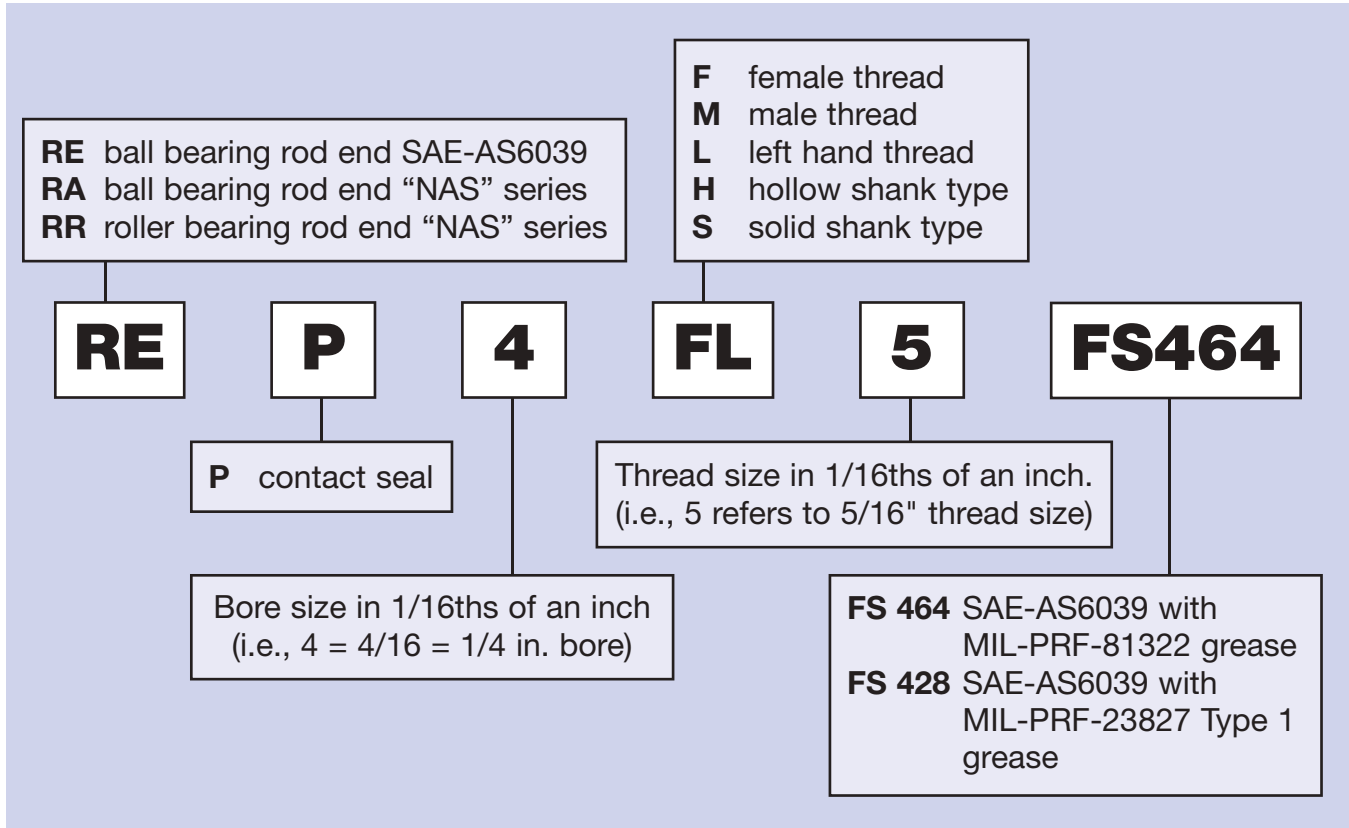

BALL BEARING
ROD ENDS

MS21151 • SAE-AS6039

- Precision series
- Double row, ball, self-aligning
- 10° permissible misalignment in either direction
- These bearings are manufactured with an internal play of .0004 in. (.010mm) max.
- Inner and outer raceway surface finish = 8 micro in. AA max.
- Equipped with PTFE seals
- Exposed surfaces except bore, cap, and seals are cadmium plated
- Outer shank – 90,000 psi min. tensile strength
- Pre-lubricated (refer to nomenclature page)

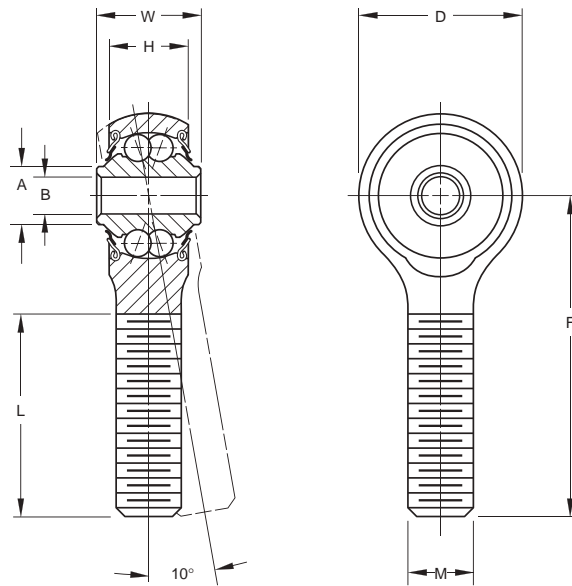

SPECIFICATIONS AND ORDERING INFORMATION

TO ORDER, SPECIFY BEARING NUMBER AND FACTORY SPECIFICATION. SEE TABLE 1 ON PG 8. (Example REP3MR3 FS464)

Bearing Number	MS 21151 Dash No.	Bore B		Outside Diameter D		Widths		A		F		L ⁽¹⁾		M UNJF-3A Threads Per AS8879	Wt.		Radial Limit Load Rating			
		+0.0000, -0.0003 +0.000, -0.008		±.010 ±.25		+0.000, -0.005 +0.00, -.13		±.010 ±.25		Approx.		±.010 ±.25			±.031 ±.79		Approx.			
		in.	mm	in.	mm	in.	mm	in.	mm	in.	mm	in.	mm		lbs.	kg	lbf.	N		
REP3MR3	-2	0.1900	4.826	0.781	19.84	0.437	11.10	0.328	8.33	0.281	7.14	1.375	34.92	0.750	19.05	10-32RH	0.04	0.018	1000	4400
REP3ML3	-1	0.1900	4.826	0.781	19.84	0.437	11.10	0.328	8.33	0.281	7.14	1.375	34.92	0.750	19.05	10-32LH	0.04	0.018	1000	4400
REP3M4-6	-7	0.1900	4.826	0.781	19.84	0.437	11.10	0.328	8.33	0.281	7.14	1.562	39.67	1.000	25.40	1/4-28RH	0.05	0.023	1000	4400
REP3MS4-6 ⁽²⁾	-7C	0.1900	4.826	0.781	19.84	0.437	11.10	0.328	8.33	0.281	7.14	1.562	39.67	1.000	25.40	1/4-28RH	0.05	0.023	1000	4400
REP3M6-2N	-4	0.1900	4.826	0.781	19.84	0.437	11.10	0.328	8.33	0.281	7.14	1.375	34.92	0.750	19.05	3/8-24RH	0.05	0.023	1000	4400
REP3MS6-2N ⁽²⁾	-4C	0.1900	4.826	0.781	19.84	0.437	11.10	0.328	8.33	0.281	7.14	1.375	34.92	0.750	19.05	3/8-24RH	0.05	0.023	1000	4400
REP3ML6-2N	-5	0.1900	4.826	0.781	19.84	0.437	11.10	0.328	8.33	0.281	7.14	1.375	34.92	0.750	19.05	3/8-24LH	0.05	0.023	1000	4400
REP3MLS6 ⁽²⁾	-5C	0.1900	4.826	0.781	19.84	0.437	11.10	0.328	8.33	0.281	7.14	1.375	34.92	0.750	19.05	3/8-24LH	0.05	0.023	1000	4400
RAP3M4-2	-6	0.1900	4.826	0.781	19.84	0.500	12.70	0.438	11.13	0.312	7.92	1.812	46.02	0.938	23.83	1/4-28RH	0.10	0.045	1000	4400
RAP3MS4-2 ⁽²⁾	-6C	0.1900	4.826	0.781	19.84	0.500	12.70	0.438	11.13	0.312	7.92	1.812	46.02	0.938	23.83	1/4-28RH	0.10	0.045	1000	4400
REP3M6A	-3	0.1900	4.826	0.969	24.61	0.500	12.70	0.407 ⁽⁴⁾	10.34	0.304	7.72	2.031	51.59	1.313	33.35	3/8-24RH	0.115	0.052	1200	5300
REP3MS6A ⁽²⁾	-3C	0.1900	4.826	0.969	24.61	0.500	12.70	0.407 ⁽⁴⁾	10.34	0.304	7.72	2.031	51.59	1.313	33.35	3/8-24RH	0.115	0.052	1200	5300
REP4M6	-8	0.2500	6.350	0.938	23.83	0.593	15.06	0.438	11.13	0.345	8.76	1.875	47.62	1.125	28.58	3/8-24RH	0.10	0.045	1720	7650
REP4M6-4 ⁽²⁾	-8C	0.2500	6.350	0.938	23.83	0.593	15.06	0.438	11.13	0.345	8.76	1.875	47.62	1.125	28.58	3/8-24RH	0.10	0.045	1720	7650
REP4ML6	-9	0.2500	6.350	0.938	23.83	0.593	15.06	0.438	11.13	0.345	8.76	1.875	47.62	1.125	28.58	3/8-24LH	0.10	0.045	1720	7650
REP4ML6-4 ⁽²⁾	-9C	0.2500	6.350	0.938	23.83	0.593	15.06	0.438	11.13	0.345	8.76	1.875	47.62	1.125	28.58	3/8-24LH	0.10	0.045	1720	7650
REP5M6	-10	0.3125	7.938	1.250	31.75	0.870	22.10	0.656	16.66	0.506	12.85	2.438	61.93	1.563	39.70	3/8-24RH	0.24	0.109	2920	12900
REP5M6-2 ⁽²⁾	-10C	0.3125	7.938	1.250	31.75	0.870	22.10	0.656	16.66	0.506	12.85	2.438	61.93	1.563	39.70	3/8-24RH	0.24	0.109	2920	12900
REP5M7	-11	0.3125	7.938	1.250	31.75	0.870	22.10	0.656	16.66	0.506	12.85	2.438	61.93	1.563	39.70	7/16-20RH	0.24	0.109	2920	12900
REP5MS7 ⁽²⁾	-11C	0.3125	7.938	1.250	31.75	0.870	22.10	0.656	16.66	0.506	12.85	2.438	61.93	1.563	39.70	7/16-20RH	0.24	0.109	2920	12900
REP5M10	-12	0.3125	7.938	1.250	31.75	0.870	22.10	0.656	16.66	0.506	12.85	2.438	61.93	1.563	39.70	5/8-18RH	0.24	0.109	2920	12900
REP5MS10 ⁽²⁾	-12C	0.3125	7.938	1.250	31.75	0.870	22.10	0.656	16.66	0.506	12.85	2.438	61.93	1.563	39.70	5/8-18RH	0.24	0.109	2920	12900
REP8M10 ⁽³⁾	-	0.5000	12.700	1.875	47.62	1.000	25.40	0.844	21.44	0.688	17.48	3.031	76.99	1.750	44.45	5/8-18RH	0.55	0.249	6900	30500
RAP10M10	-13	0.6250	15.875	2.000	50.80	1.125	28.58	0.938	23.83	0.875	22.22	2.750	69.85	1.500	38.10	5/8-18RH	0.71	0.322	7090	31500
RAP10MS10 ⁽²⁾	-13C	0.6250	15.875	2.000	50.80	1.125	28.58	0.938	23.83	0.875	22.22	2.750	69.85	1.500	38.10	5/8-18RH	0.71	0.322	7090	31500

⁽¹⁾ Length includes maximum of two incomplete threads.

⁽²⁾ NAS 513 keyway in shank.

⁽³⁾ 5° permissible misalignment in either direction.

⁽⁴⁾ +.000 in. (+.00 mm), -.015 in. (-.38mm).

AeroCres® Fracture-tough Airframe Products

Fracture-tough airframe products enhance corrosion resistance

For many years, corrosion has been a significant problem with bearings used in the aircraft industry. While CRES 440C has been used successfully in many aircraft applications, it is not suitable for the demands of rod end banjos or track roller studs. These two bearing components require a full Rc 58 hardness in the raceway area and a softer, tougher material elsewhere. This is not attainable with CRES 440C. RBC's AeroCres® products provide the unique solution that meets these dual material requirements.

We have selected a specialized carburized stainless steel, and have developed and optimized the heat treatment process that resulted in a homogeneous microstructure — delivering both corrosion protection and core fracture toughness.

Currently, this new material is being used for many structural bearing components such as rod end banjos, track roller studs, and outer rings. Fracture toughness, corrosion resistance, and long fatigue life are critical requirements for these components.



AeroCres® fracture-tough airframe products offer enhanced corrosion resistance in harsh operating environments.

BALL BEARING
ROD ENDS

Benefits

- Excellent fracture toughness superior to CRES 440C.
- Proven corrosion resistance similar to CRES 440C.
- Compressive residual stresses in carburized case.
- Lower starting torque after extended exposure to a neutral salt solution (ASTM-G44).
- Meets or exceeds government requirements for fatigue and static testing per AS 39901.
- Longer bearing life resisting premature corrosion.

Applications

Bearings located in exposed corrosive positions of aircraft such as:

- Landing gear and doors
- Leading and trailing edges
- Engine controls
- Tail sections

© 2008, 2011, 2018 RBC Bearings Incorporated. All rights reserved.

AeroCres® Fracture-tough Airframe Products

Corrosion Resistance Comparison

AeroCres® Rod End vs. 8620/52100 Rod End



**Alternate Immersion Corrosion Test
ASTM G44-88
Results* (1,000 hours)**

Standard Assembly:
8620 rod end outers with 52100 steel inner ring and balls

Corrosion Resistant CRES Assembly:
AeroCres® rod end outer with CRES 440C inner ring and balls

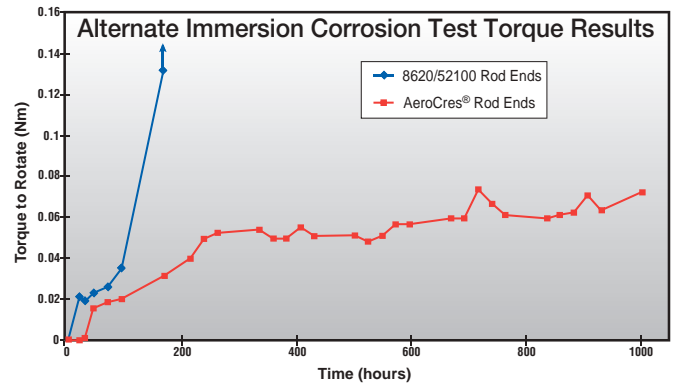

Fig. 6 – Average Torque to Rotate for Three Bearings of Each Type of Rod End

**Salt Spray Test Results
(1,000 hours) ASTM-B117**



Plated 8620 Rod End Outer with 52100 Steel Inner Ring and Balls

**Alternative Immersion Corrosion Test
ASTM-G44-88
Results* (1,000 hours)**



Plated AeroCres® Rod End Outer with CRES 440C Inner Ring and Balls

Microstructure AeroCres® fracture-tough material vs. CRES 440C

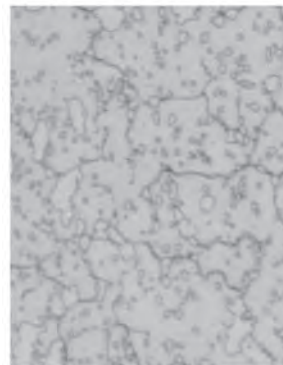

CRES 440C



AeroCres® fracture-tough material

Approvals

- BACB10GS
- BACB10GY
- BACB10GZ

Engineering Support

- Application consultation
- Product design
- Product testing
- Metallurgical analysis
- Heat treating, stainless, and other high-alloy steels

Ordering Information

- Contact RBC Customer Service

BALL BEARING ROD ENDS

MS21153 • SAE-AS6039

- Precision series
- Double row, ball, self-aligning
- 10° permissible misalignment in either direction
- These bearings are manufactured with an internal play of .0004 in. (.010mm) max.
- Inner and outer raceway surface finish = 8 micro in. AA max.
- Equipped with PTFE seals
- Exposed surfaces except bore, cap, and seals are cadmium plated
- Outer shank – 90,000 psi min. tensile strength
- Pre-lubricated (refer to nomenclature page)

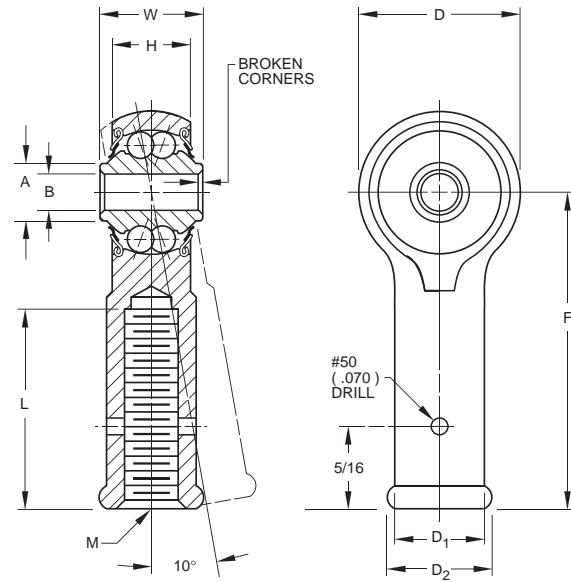

SPECIFICATIONS AND ORDERING INFORMATION

TO ORDER, SPECIFY BEARING NUMBER AND FACTORY SPECIFICATION. SEE TABLE 1 ON PG 8. (Example REPB3N FS464)

Bearing Number	MS 21153 Dash No.	Bore B		Outside Diameter D		Widths		A	F	L ⁽¹⁾	D ²	D ¹	M UNJF-3B Threads Per AS8879	Wt.		Radial Limit Load Rating								
		+0.0000, -0.0003 +0.000, -0.008	±.010 ±.25	+0.000, -0.005 +0.00, -.13	±.010 ±.25	in.	mm							in.	mm	in.	mm	lbs.	kg	lbf.	N			
REPB3N	-1	0.1900	4.826	0.781	19.84	0.437	11.10	0.328	8.33	0.281	7.14	1.375	34.92	0.750	19.05	0.438 ⁽³⁾	11.13 ⁽⁴⁾	0.375	9.52	1/4-28RH	0.05	0.023	1000	4400
REP3FL4-3	-5	0.1900	4.826	0.781	19.84	0.437	11.10	0.328	8.33	0.281	7.14	1.375	34.92	0.750	19.05	0.438 ⁽³⁾	11.13 ⁽⁴⁾	0.375	9.52	1/4-28LH	0.05	0.023	1000	4400
REPB3N-2	-2	0.1900	4.826	0.781	19.84	0.437	11.10	0.328	8.33	0.281	7.14	1.375	34.92	0.750	19.05	0.438 ⁽³⁾	11.13 ⁽⁴⁾	0.438	11.13	5/16-24RH	0.06	0.027	1000	4400
REP3F4	-3	0.1900	4.826	0.781	19.84	0.500	12.70	0.328	8.33	0.281	7.14	1.375	34.92	0.750	19.05	0.438 ⁽³⁾	11.13 ⁽⁴⁾	0.375	9.52	1/4-28RH	0.06	0.027	1000	4400
REP3FL4	-4	0.1900	4.826	0.781	19.84	0.500	12.70	0.328	8.33	0.281	7.14	1.375	34.92	0.750	19.05	0.438 ⁽³⁾	11.13 ⁽⁴⁾	0.375	9.52	1/4-28LH	0.06	0.027	1000	4400
REP4F5	-6	0.2500	6.350	0.938	23.83	0.593	15.06	0.438	11.13	0.345	8.76	1.469	37.31	0.750	19.05	0.438 ⁽³⁾	11.13 ⁽⁴⁾	0.438	11.13	5/16-24RH	0.07	0.032	1720	7650
REP4F5-5 ⁽²⁾	-6C	0.2500	6.350	0.938	23.83	0.593	15.06	0.438	11.13	0.345	8.76	1.469	37.31	0.750	19.05	0.438 ⁽³⁾	11.13 ⁽⁴⁾	0.438	11.13	5/16-24RH	0.07	0.032	1720	7650
REP4FL5 ⁽²⁾	-7	0.2500	6.350	0.938	23.83	0.593	15.06	0.438	11.13	0.345	8.76	1.469	37.31	0.750	19.05	0.438 ⁽³⁾	11.13 ⁽⁴⁾	0.438	11.13	5/16-24LH	0.07	0.032	1720	7650
REP4FL5-5 ⁽²⁾	-7C	0.2500	6.350	0.938	23.83	0.593	15.06	0.438	11.13	0.345	8.76	1.469	37.31	0.750	19.05	0.438 ⁽³⁾	11.13 ⁽⁴⁾	0.438	11.13	5/16-24LH	0.07	0.032	1720	7650
REP4F7	-8	0.2500	6.350	0.938	23.83	0.593	15.06	0.438	11.13	0.345	8.76	1.875	47.62	1.125	28.58	0.625	15.88	0.625	15.88	7/16-20RH	0.08	0.036	1720	7650
REP4FL7	-9	0.2500	6.350	0.938	23.83	0.593	15.06	0.438	11.13	0.345	8.76	1.875	47.62	1.125	28.58	0.625	15.88	0.625	15.88	7/16-20LH	0.08	0.036	1720	7650
REP5F5	-10	0.3125	7.938	1.250	31.75	0.870	22.10	0.656	16.66	0.501	12.73	1.875	47.62	1.000	25.40	0.483	11.13	0.438	11.13	5/16-24RH	0.1	0.045	2920	12900
REP5FL5	-11	0.3125	7.938	1.250	31.75	0.870	22.10	0.656	16.66	0.501	12.73	1.875	47.62	1.000	25.40	0.483	11.13	0.438	11.13	5/16-24LH	0.1	0.045	2920	12900

⁽¹⁾ Length includes maximum of two incomplete threads.

⁽²⁾ NAS 513 locking slot in shank.

⁽³⁾ Bead diameter.

⁽⁴⁾ Hex diameter across flats.

BALL BEARING ROD ENDS

BALL BEARING ROD ENDS — REP SERIES HOLLOW & SOLID SHANK



MS21152/MS21150 • SAE-AS6039

- Precision series
- Double row, ball, self-aligning
- 10° permissible misalignment in either direction
- These bearings are manufactured with an internal play of .0004 in. (.010mm) max.
- Inner and outer raceway surface finish = 8 micro in. AA max.
- Equipped with PTFE seals
- Exposed surfaces except bore, cap, and seals are cadmium plated
- Outer shank - 90,000 psi min. tensile strength

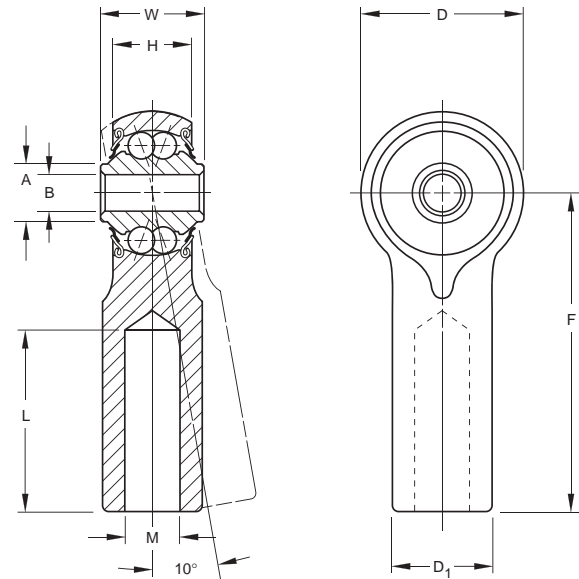

SPECIFICATIONS AND ORDERING INFORMATION

TO ORDER, SPECIFY BEARING NUMBER AND FACTORY SPECIFICATION. SEE TABLE 1 ON PG 8. (Example REP3H5 FS464)

Bearing Number	MS 21152 Dash No.	Bore B		Outside Diameter D		Widths W H		A	F	L ⁽¹⁾	D ₁	M	Wt.		Radial Limit Load Rating								
		in.	mm	in.	mm	in.	mm						in.	mm	lbs.	kg	lbf.	N					
		+0.0000,-.0003 +0.000,-.008		±.010 ±.25		+0.000,-.005 +0.00,-.13		±.010 ±.25		Approx.	±.010 ±.25	±.031 ±.79	+0.000,-.002 +0.00,-.05		±.010 ±.25		Approx.						
HOLLOW SHANK																							
REP3H5	-1	0.1900	4.826	0.781	19.84	0.437	11.10	0.328	8.33	0.281	7.14	1.375	34.92	0.875	22.22	0.430	10.92	0.272	6.91	0.06	0.027	1000	4400
REP4H8	-3	0.2500	6.350	0.938	23.83	0.593	15.06	0.438	11.13	0.345	8.76	1.625	41.28	0.875	22.22	0.625	15.88	0.515	13.08	0.08	0.036	1720	7650
REP4H5-2	-4	0.2500	6.350	0.938	23.83	0.593	15.06	0.438	11.13	0.345	8.76	1.875	47.62	0.750	19.05	0.438	11.13	0.346	8.79	0.12	0.054	1720	7650
REP4H8-2	-5	0.2500	6.350	0.938	23.83	0.593	15.06	0.438	11.13	0.345	8.76	1.875	47.62	1.125	28.58	0.625	15.88	0.500	12.70	0.09	0.041	1720	7650
REP4H6	-2	0.2500	6.350	0.938	23.83	0.593	15.06	0.438	11.13	0.345	8.76	1.875	47.62	1.219	30.96	0.625	15.88	0.386	9.80	0.12	0.054	1720	7650
REP5H8	-	0.3125	7.938	1.250	31.75	0.870	22.10	0.656	16.66	0.506	12.85	2.438	61.93	1.562	39.67	0.625	15.88	0.500	12.70	0.15	0.068	2920	12900
REP8H10	-	0.5000	12.700	1.875	47.62	1.000	25.40	0.844	21.44	0.688	17.48	3.031	76.99	1.640	41.66	0.625	15.88	0.438	11.13	0.55	0.249	6900	30500
	MS 21150																						
SOLID SHANK																							
REP3S7	-1	0.1900	4.826	0.781	19.84	0.437	11.10	0.328	8.33	0.281	7.14	1.375	34.92	-	-	0.430	10.92	-	-	0.07	0.032	1000	4400
REP4S10	-2	0.2500	6.350	0.938	23.83	0.593	15.06	0.438	11.13	0.345	8.76	1.875	47.62	-	-	0.625	15.88	-	-	0.16	0.073	1720	7650

NAS-659

- NAS-659 series⁽¹⁾
- Self-aligning
- 3-way balanced design brings shank strength, bolt strength and bearing capacity all in balance
- “Pressurized” shanks are designed to withstand column action under compression with angularity as high as 9°
- Exposed surfaces except bore, cap, and seals are cadmium plated

- Keyway in shank is designed in accordance with NAS-513 standards for use with NAS-509 drilled jam nuts and either NAS-513 rod end locking washers or NAS-559 rod end key type locks
- Permissible misalignment is 10° in either direction (total 20°)
- Ultimate shank tensile strength is 125,000 to 180,000 psi
- Equipped with molded rubber seals when specified

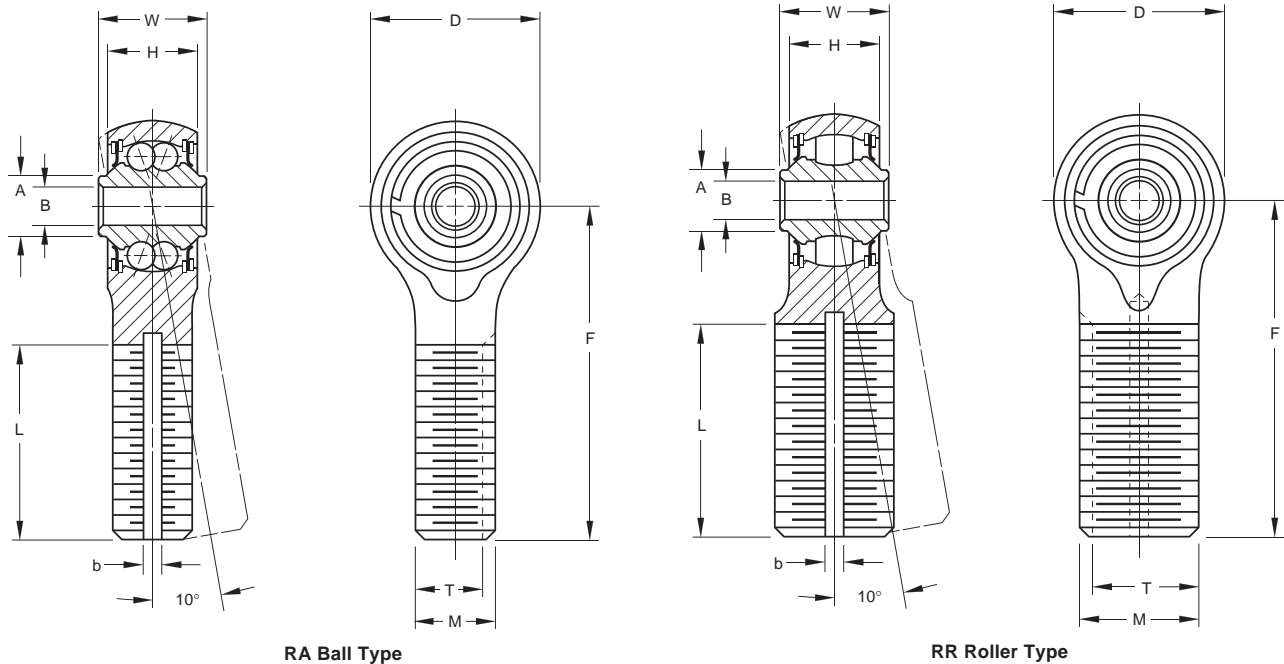

BALL BEARING ROD ENDS

SPECIFICATIONS AND ORDERING INFORMATION

TO ORDER, SPECIFY BEARING NUMBER AND FACTORY SPECIFICATION. SEE TABLE 1 ON PG 8. (Example RA3M5 FS464)

Bearing ⁽¹⁾ Number	NAS 659 Dash No.	Bore B		Outside Diameter D		Widths W H		A	F	L ⁽²⁾	b ⁽³⁾	T ⁽³⁾	M UNJF-3A Threads Per AS8879	Wt.		Radial Limit Load Rating								
		in.	mm	in.	mm	in.	mm							in.	mm		in.	mm	lbs.	kg				
RA3M5	-3-5	0.1900	4.826	0.781	19.84	0.562	14.27	0.438	11.13	0.312	7.92	1.938	49.23	1.375	34.92	0.062	1.57	0.26	6.6	5/16-24	0.07	0.032	1000	4400
RA3M5-2 ⁽⁵⁾	—	0.1900	4.826	0.781	19.84	0.500	12.70	0.438	11.13	0.312	7.92	1.938	49.23	1.375	34.92	0.062	1.57	0.26	6.6	5/16-24	0.07	0.032	1000	4400
RA4M7	-4-7	0.2500	6.350	0.938	23.83	0.687	17.45	0.531	13.49	0.365	9.27	2.250	57.15	1.625	41.28	0.093	2.36	0.37	9.4	7/16-20	0.13	0.059	1720	7650
RR4M9	R4-9	0.2500	6.350	1.063	27.00	0.625	15.88	0.469	11.91	0.404	10.26	2.563	65.10	1.875	47.62	0.125	3.18	0.478	12.14	9/16-18	0.21	0.095	3025	13400
RR5M12	R5-12	0.3125	7.938	1.438	36.53	0.812	20.62	0.656	16.66	0.515	13.08	3.125	79.38	2.219	56.36	0.125	3.18	0.663	16.84	3/4-16	0.47	0.213	7350	32500
RR6M14	R6-14	0.3750	9.525	1.750	44.45	0.937	23.80	0.750	19.05	0.564	14.33	3.563	90.50	2.438	61.93	0.156	3.96	0.777	19.74	7/8-14	0.72	0.327	9600	42500

⁽¹⁾ When ordering as NAS part, add suffix “FS237” to part number. (Example RA4M7 FS237)

⁽²⁾ Threads: UNJF-3A (based on length of engagement = 1.25 thd. diam. + 5/8).

⁽³⁾ Slots conform to NAS 513 standards.

⁽⁴⁾ Thrust rating is 20% of radial load rating.

⁽⁵⁾ This size not covered by NAS 659. Lightening holes in shank RR5M12-1/4 in. x 2 5/16 in.
RR6M14-3/8 in. x 2 9/16 in.

Add letter “L” to part number for left hand threads. Example: RA3ML5.

NAS-660

- NAS-660 series⁽¹⁾
- Self-aligning
- 3-way balanced design brings shank strength, bolt strength and bearing capacity all in balance
- “Pressurized” shanks are designed to withstand column action under compression with angularity as high as 9°

- Permissible misalignment is 10° in either direction (total 20°)
- Ultimate shank tensile strength is 125,000 to 180,000 psi
- Equipped with molded rubber seals when specified
- Exposed surfaces except bore, cap, and seals are cadmium plated
- Prepacked with lubricant conforming to MIL-PRF-23827, Type 1

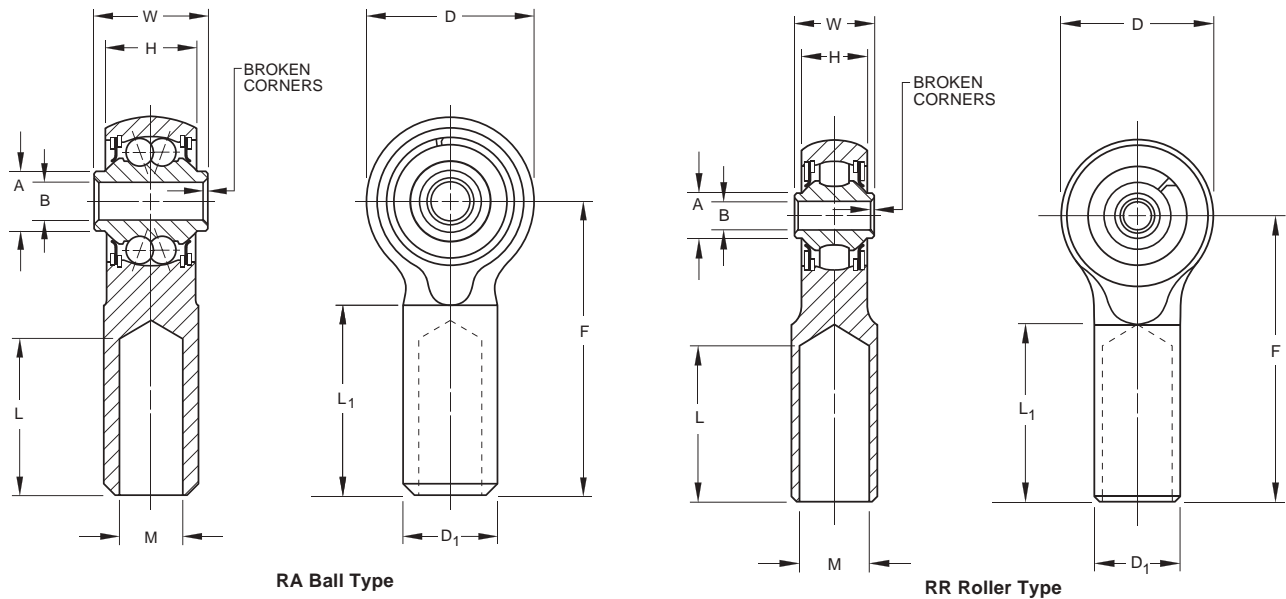

RA Ball Type

RR Roller Type

SPECIFICATIONS AND ORDERING INFORMATION

TO ORDER, SPECIFY BEARING NUMBER AND FACTORY SPECIFICATION. SEE TABLE 1 ON PG 8. (Example RA3H7 FS464)

Bearing ⁽¹⁾ Number	NAS 660 Dash No.	Bore B		Outside Diameter D		Widths W H		A	L	L ₂	L ₁	D ₁	L ₃	M	Wt.	Radial Limit Load Rating											
		+0.0000,-0.0005 +0.000,-0.013	±.010 ±.25	+0.000,-.005 +0.00,-.13	+0.010,-.005 +0.25,-.13	Approx.	±.010 ±.25										REF.	±.010 ±.25	+0.000,-0.002 +0.25,-.05	+0.010,-0.001 +0.25,-.03	Approx.						
		in.	mm	in.	mm	in.	mm	in.	mm	in.	mm	in.	mm	in.	mm	lbs.	kg	lbf.	N								
RA3H7	-3-7	0.1900	4.826	0.781	19.84	0.562	14.27	0.438	11.13	0.312	7.92	1.538	39.07	1.934	49.12	0.785	19.94	0.430	10.92	0.975	24.76	0.281	7.14	0.06	0.027	1000	4400
RA4H9	-4-9	0.2500	6.350	0.938	23.83	0.687	17.45	0.531	13.49	0.365	9.27	1.75	44.45	2.219	56.36	0.941	23.90	0.555	14.10	1.125	28.58	0.406	10.31	0.12	0.054	1720	7650
RA4H11	R4-11	0.2500	6.350	1.063	27.00	0.625	15.88	0.469	11.91	0.404	10.26	2.163	54.94	2.694	68.43	1.285	32.64	0.680	17.27	1.475	37.46	0.516	13.11	0.19	0.086	3025	13400
RR5H14	R5-14	0.3125	7.938	1.438	36.53	0.812	20.62	0.656	16.66	0.515	13.08	2.906	73.81	3.625	92.08	1.785	45.34	0.870	22.10	2.094	53.19	0.703	17.86	0.4	0.181	7350	32500
RR6H16	R6-16	0.3750	9.525	1.750	44.45	0.937	23.80	0.750	19.05	0.564	14.33	3.25	82.55	4.125	104.78	1.785	45.34	0.995	25.27	2.000	50.80	0.812	20.62	0.66	0.299	9600	42500

⁽¹⁾ When ordering as NAS part, add suffix “FS237” to part number. (Example RA4H11 FS237)

⁽²⁾ Thrust rating is 20% of radial load rating.

RBC Airframe Control Radial Bearings

RADIAL BEARINGS

Single Row, Deep Groove Ball Bearings

PRODUCT NOMENCLATURE	70
9300K series Ultra-Light	71
9100K series Extra-Light	72
Engineering	73-74

GENERAL FEATURES AND TECHNICAL SPECIFICATIONS

Seals and Shields

Bearings are available open, with shields, or with seals.

Inner and Outer Rings, and Balls

Rings and balls are made from thru-hardened 52100 or CRES 440C to accommodate the application's corrosion resistance needs. The external ring surfaces may also be plated with cadmium or zinc nickel to provide protection from galvanic corrosion.



Lubrication

Bearings are lubricated with greases, oils, or preservatives in compliance with MIL-PRF-23827, Boeing BMS3-33, MIL-PRF-81322, MIL-PRF-6085, or MIL-PRF-8188.

Retainers or Cages

Retainers are machined or stamped from steel, bronze, or composition material. Two-piece retainers are assembled with a variety of methods, including welding, riveting, and crimping.

Construction

These single row bearings are constructed Conrad style without filling slots. The 9100K series has a thicker cross-section than the 9300K series. Both series are ideally suited for applications where housing diameters are restricted and it is desirable to maintain relatively large shaft diameters.

RADIAL
BALL BEARINGS

RADIAL BALL BEARINGS

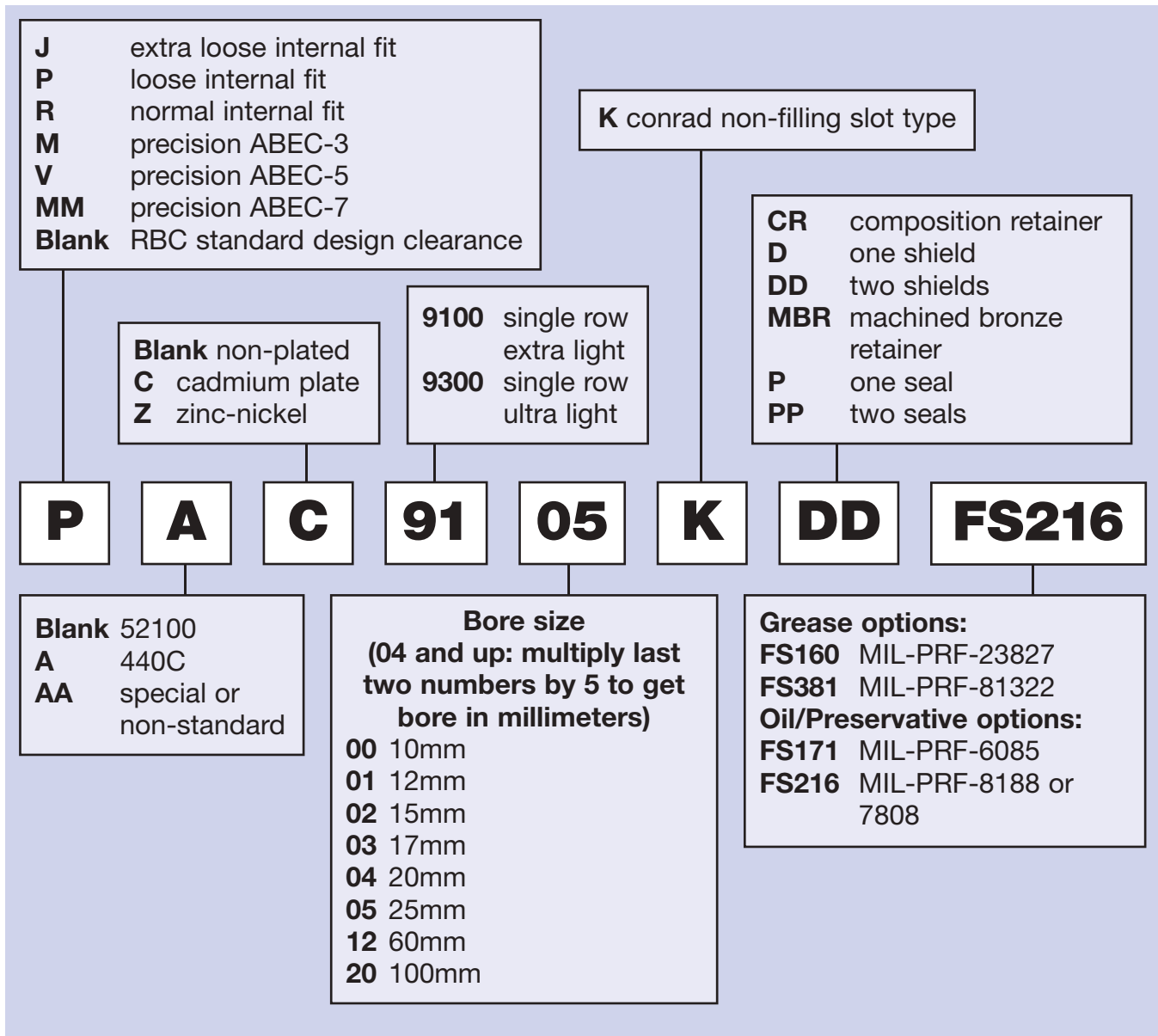

RADIAL BALL BEARINGS

ULTRA-LIGHT 9300K SERIES

- Single row, ball, deep groove, ultra-light radial bearing
- Available as open type, shielded, or sealed
- Multiple lube options

- Bearings are designed principally for applications where housing diameters are restricted and it is desirable to maintain relatively large shaft diameters
- Offered with 52100 and CRES 440C material

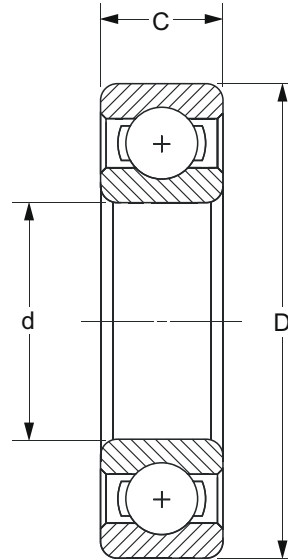

RADIAL BALL BEARINGS

SPECIFICATIONS AND ORDERING INFORMATION

DIMENSIONS - TOLERANCES (ABEC-1)

Bearing Number	Bore d		tolerance		Outside Diameter D		tolerance		Width C		tolerance		Fillet Radius (1)		Wt.		Static Load Rating C ₀		Dynamic Load Rating C _R	
	in.	mm	+0.000 to minus	+0.000 to minus	in.	mm	+0.000 to minus	+0.000 to minus	in.	mm	in.	mm	in.	mm	lbs.	kg	lbs.	N	lbs.	N
9300K	0.3937	10	0.0003	0.008	0.8661	22	0.00035	0.009	0.236	6	0.005	0.12	0.012	0.3	0.02	0.009	290	1270	610	2700
9301K	0.4724	12	0.0003	0.008	0.9449	24	0.00035	0.009	0.236	6	0.005	0.12	0.012	0.3	0.03	0.014	360	1610	750	3330
9302K	0.5906	15	0.0003	0.008	1.1024	28	0.00035	0.009	0.276	7	0.005	0.12	0.012	0.3	0.04	0.018	510	2250	970	4320
9303K	0.6693	17	0.0003	0.008	1.1811	30	0.00035	0.009	0.276	7	0.005	0.12	0.012	0.3	0.06	0.027	570	2550	1030	4600
9304K	0.7874	20	0.0004	0.010	1.4567	37	0.00035	0.009	0.354	9	0.005	0.12	0.012	0.3	0.08	0.036	830	3680	1430	6380
9305K	0.9843	25	0.0004	0.010	1.6535	42	0.00045	0.011	0.354	9	0.005	0.12	0.012	0.3	0.10	0.045	1020	4530	1580	7030
9306K	1.1811	30	0.0004	0.010	1.8504	47	0.00045	0.011	0.354	9	0.005	0.12	0.012	0.3	0.16	0.075	1130	5010	1630	7240
9307K	1.3780	35	0.00045	0.012	2.1654	55	0.0005	0.013	0.394	10	0.005	0.12	0.024	0.6	0.21	0.095	1530	6830	2150	9550
9308K	1.5748	40	0.00045	0.012	2.4409	62	0.0005	0.013	0.472	12	0.005	0.12	0.024	0.6	0.31	0.141	2000	8900	2730	12200
9309K	1.7717	45	0.00045	0.012	2.6772	68	0.0005	0.013	0.472	12	0.005	0.12	0.024	0.6	0.35	0.159	2440	10900	3170	14100
9310K	1.9685	50	0.00045	0.012	2.8346	72	0.0005	0.013	0.472	12	0.005	0.12	0.024	0.6	0.37	0.168	2630	11700	3270	14500
9311K	2.1654	55	0.0006	0.015	3.1496	80	0.0005	0.013	0.512	13	0.006	0.15	0.039	1.0	0.46	0.209	3160	14100	3740	16600
9312K	2.3622	60	0.0006	0.015	3.3465	85	0.0006	0.015	0.512	13	0.005	0.12	0.039	1.0	0.51	0.231	3390	15100	3820	17400
9313K	2.5591	65	0.0006	0.015	3.5433	90	0.0006	0.015	0.512	13	0.006	0.15	0.039	1.0	0.55	0.250	4160	18500	4660	20700
9314K	2.7559	70	0.0006	0.015	3.9370	100	0.0006	0.015	0.630	16	0.005	0.12	0.039	1.0	0.64	0.290	4750	21100	5330	23700
9315K	2.9528	75	0.0006	0.015	4.1339	105	0.0006	0.015	0.630	16	0.005	0.12	0.039	1.0	0.72	0.327	5350	23800	5670	25200
9316K	3.1496	80	0.0006	0.015	4.3307	110	0.0006	0.015	0.630	16	0.006	0.15	0.039	1.0	0.80	0.363	5370	23900	5610	24900

(1) Indicates maximum shaft or housing fillet radius which bearing corners will clear.

EXTRA-LIGHT 9100K SERIES

- Single row, ball, deep groove, extra-light radial bearing
- Available as open type, shielded or sealed
- Multiple lube options
- Bearings are designed principally for applications where housing diameters are restricted and it is desirable to maintain relatively large shaft diameters

- This series resembles the 9300K series except that corresponding sizes on the 9100K series have a thicker cross-section
- Offered with 52100 and CRES 440C material

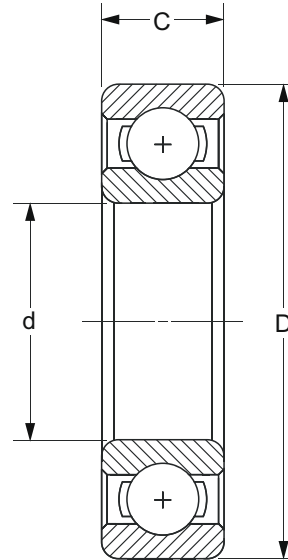

SPECIFICATIONS AND ORDERING INFORMATION

DIMENSIONS - TOLERANCES (ABEC-1)

Bearing Number	Bore d		tolerance		Outside Diameter D		tolerance		Width C		tolerance		Fillet Radius (1)		Wt.		Static Load Rating C ₀		Dynamic Load Rating C _R	
	in.	mm	+0.000 to minus	+0.000 to minus	in.	mm	+0.000 to minus	+0.000 to minus	in.	mm	+0.000 to minus	+0.000 to minus	in.	mm	lbs.	kg	lbs.	N	lbs.	N
9100K	0.3937	10	0.0003	0.008	1.0236	26	0.00035	0.009	0.3150	8	0.005	0.12	0.012	0.3	0.03	0.014	440	1970	1030	4580
9101K	0.4724	12	0.0003	0.008	1.1024	28	0.00035	0.009	0.3150	8	0.005	0.12	0.012	0.3	0.04	0.018	540	2390	1150	5120
9102K	0.5906	15	0.0003	0.008	1.2598	32	0.00045	0.011	0.3543	9	0.005	0.12	0.012	0.3	0.06	0.027	640	2840	1260	5590
9103K	0.6693	17	0.0003	0.008	1.3780	35	0.00045	0.011	0.3937	10	0.005	0.12	0.012	0.3	0.09	0.041	730	3250	1350	6000
9104K	0.7874	20	0.0004	0.010	1.6535	42	0.00045	0.011	0.4724	12	0.005	0.12	0.024	0.6	0.16	0.073	1130	5030	2110	9380
9105K	0.9843	25	0.0004	0.010	1.8504	47	0.00045	0.011	0.4724	12	0.005	0.12	0.024	0.6	0.17	0.077	1320	5850	2260	10100
9106K	1.1811	30	0.0004	0.010	2.1654	55	0.0005	0.013	0.5118	13	0.005	0.12	0.039	1.0	0.26	0.118	1870	8300	2970	13200
9107K	1.3780	35	0.00045	0.012	2.4409	62	0.0005	0.013	0.5512	14	0.005	0.12	0.039	1.0	0.32	0.145	2310	10300	3590	16000
9108K	1.5748	40	0.00045	0.012	2.6772	68	0.0005	0.013	0.5906	15	0.005	0.12	0.039	1.0	0.43	0.195	2810	12500	3980	17700
9109K	1.7717	45	0.00045	0.012	2.9528	75	0.0005	0.013	0.6299	16	0.005	0.12	0.039	1.0	0.55	0.249	3410	15200	4720	21000
9110K	1.9685	50	0.00045	0.012	3.1496	80	0.0005	0.013	0.6299	16	0.005	0.12	0.039	1.0	0.60	0.272	3720	16600	4910	21800
9111K	2.1654	55	0.0006	0.015	3.5433	90	0.0006	0.015	0.7087	18	0.006	0.15	0.039	1.0	0.86	0.390	4780	21300	6360	28300
9112K	2.3622	60	0.0006	0.015	3.7402	95	0.0006	0.015	0.7087	18	0.006	0.15	0.039	1.0	0.92	0.417	5210	23200	6620	29400
9113K	2.5591	65	0.0006	0.015	3.9370	100	0.0006	0.015	0.7087	18	0.006	0.15	0.039	1.0	0.98	0.445	5650	25200	6870	30500
9114K	2.7559	70	0.0006	0.015	4.3307	110	0.0006	0.015	0.7874	20	0.006	0.15	0.039	1.0	1.39	0.630	6940	30900	8550	38100
9115K	2.9528	75	0.0006	0.015	4.5276	115	0.0006	0.015	0.7874	20	0.006	0.15	0.039	1.0	1.50	0.680	7520	33500	8890	39500
9116K	3.1496	80	0.0006	0.015	4.9213	125	0.0007	0.018	0.8661	22	0.006	0.15	0.039	1.0	1.95	0.885	8920	39700	10700	47600
9117K	3.3465	85	0.0008	0.020	5.1181	130	0.0007	0.018	0.8661	22	0.008	0.20	0.039	1.0	2.13	0.966	9660	43000	11100	49500
9118K	3.5433	90	0.0008	0.020	5.5118	140	0.0007	0.018	0.9449	24	0.008	0.20	0.059	1.5	2.55	1.157	11200	49600	13100	58200
9120K	3.9370	100	0.0008	0.020	5.9055	150	0.0007	0.018	0.9449	24	0.008	0.20	0.059	1.5	2.90	1.315	12200	54200	13500	60100

(1) Indicates maximum shaft or housing fillet radius which bearing corners will clear.

LIMITS FOR RADIAL INTERNAL CLEARANCE OF SINGLE ROW, RADIAL CONTACT BALL BEARINGS

Basic Bore Diameter MM		R Prefix				P Prefix				J Prefix			
Over	Include	Low		High		Low		High		Low		High	
mm	mm	in.	mm	in.	mm	in.	mm	in.	mm	in.	mm	in.	mm
2.5	6	0.0001	0.002	0.0005	0.013	0.0003	0.008	0.0009	0.023	na	na	na	na
6	10	0.0001	0.002	0.0005	0.013	0.0003	0.008	0.0009	0.023	0.0006	0.014	0.0011	0.028
10	18	0.0001	0.002	0.0007	0.018	0.00045	0.011	0.0010	0.025	0.0007	0.018	0.0013	0.033
18	24	0.0002	0.006	0.0008	0.020	0.0005	0.013	0.0011	0.028	0.0008	0.020	0.0014	0.036
24	30	0.0002	0.006	0.0008	0.020	0.0005	0.013	0.0011	0.028	0.0009	0.023	0.0016	0.041
30	40	0.00025	0.007	0.0008	0.020	0.0006	0.015	0.0013	0.033	0.0010	0.028	0.0018	0.046
40	50	0.00025	0.007	0.0009	0.023	0.0007	0.018	0.0014	0.036	0.0012	0.030	0.0020	0.051
50	65	0.0003	0.008	0.0011	0.028	0.0009	0.023	0.0017	0.043	0.0015	0.038	0.0024	0.061
65	80	0.0004	0.010	0.0012	0.030	0.0010	0.025	0.0020	0.051	0.0018	0.046	0.0028	0.071
80	100	0.00045	0.011	0.0014	0.036	0.0012	0.030	0.0023	0.058	0.0021	0.053	0.0033	0.084

Applies to Bearings of ABEC-1, ABEC-3, ABEC-5, ABEC-7 and ABEC-9 Tolerances
Tolerance Limits in inches (.0001 in.) and millimeters

RBC Company Radial Clearance Designations Correlated with ANSI-ABMA Std. 20 Symbols

RBC PREFIX	ANSI-ABMA	DESCRIPTION
R	N	Normal Fit
P	3	Loose Fit
J	4	Extra Loose Fit

LUBRICATION VARIATIONS FOR RADIAL BALL BEARINGS

LUBRICATION	RBC SUFFIX
MIL-PRF-23827	FS160
MIL-PRF-6085	FS171
MIL-PRF-8188	FS216
MIL-PRF-81322	FS381

Capacity and Fatigue Life of Ball Bearings

The basic dynamic radial load rating, C_R , or “dynamic capacity,” for a ball bearing is the calculated, constant radial load at which 90% of a group of apparently identical bearings with stationary outer rings can statistically endure 10^6 revolutions of the inner ring. ANSI/ABMA Standard 9 with correction factors for race curvatures was used to calculate the catalog ratings.

The basic static load rating, C_0 , or “static capacity,” is that uniformly distributed load, which produces a maximum theoretical contact stress of 609,000 psi. At this contact stress, permanent deformation of ball and raceway occurs. This deformation is approximately .0001% of the ball diameter.

The rating life, L_{10} , is a statistical measure of the life which 90% of a large group of apparently identical ball bearings will achieve or exceed. For a single bearing, L_{10} also refers to the life associated with 90% reliability.

The relationship between rating life, load rating, and load is:

$$L_{10} = (C/P)^3 \text{ with } L_{10} = \text{rating life (} 10^6 \text{ rev)}$$

$$C_R = \text{basic dynamic radial load rating (lbf)}$$

$$P = \text{equivalent radial load (lbf)}$$

To obtain the rating life in hours, use:

$$L_{10 \text{ hrs}} = 16667/N * (C_R/P)^3 \text{ with } N = \text{speed (rpm)}$$

The equivalent radial load is defined as:

$$P = XF_r + YF_a \quad \text{with} \quad F_r = \text{radial load (lbf)}$$

$$F_a = \text{axial load (lbf)}$$

X - see below
Y - see below

For radial contact bearings calculate P with $X = 1$ and $Y = 0$. Then recalculate P with $X = 0.56$ and $Y =$ (see chart below).

Use the larger value of P to determine L_{10} life.

$\frac{F_a}{nd^2}$	Y
25	2.30
50	1.99
100	1.71
150	1.55
200	1.45
300	1.31
500	1.15
750	1.04
1000	1.00

$n =$ number of balls
 $d =$ diameter of balls (in.)

SHAFT AND HOUSING FITS

Radial Ball Bearing

SHAFT FITS, ABEC-1, ABEC-3, 9100, 9300 SERIES

NOTE: These tables are to be used for applications where only one ring (either inner or outer) has an interference fit with its shaft and housing

Basic Bearing Number	Bore Tolerance				Shaft Rotating, Load Stationary or Shaft Stationary, Load Rotating						Shaft Stationary, Load Stationary or Shaft Rotating, Load Rotating									
	MAX.		MIN.		Shaft diameter max.		Shaft diameter min.		(mean fit) tight ABEC-1		(mean fit) tight ABEC-3		Shaft diameter max.		Shaft diameter min.		(mean fit) loose ABEC-1		(mean fit) loose ABEC-3	
	in.	mm	in.	mm	in.	mm	in.	mm	in.	mm	in.	mm	in.	mm	in.	mm	in.	mm	in.	mm
00	0.3937	10	0.3934	9.992	0.3939	10.005	0.3936	9.997	0.0002	0.005	0.00015	0.004	0.3935	9.995	0.3931	9.985	0.00025	0.006	0.00030	0.008
01	0.4724	12	0.4721	11.992	0.4726	12.004	0.4723	11.996	0.0002	0.005	0.00015	0.004	0.4722	11.994	0.4717	11.981	0.00030	0.008	0.00035	0.009
02	0.5906	15	0.5903	14.992	0.5908	15.006	0.5905	14.999	0.0002	0.005	0.00015	0.004	0.5904	14.996	0.5899	14.983	0.00030	0.008	0.00035	0.009
03	0.6693	17	0.6690	16.992	0.6695	17.005	0.6692	16.998	0.0002	0.005	0.00015	0.004	0.6691	16.995	0.6686	16.982	0.00030	0.008	0.00035	0.009
04	0.7874	20	0.7870	19.990	0.7879	20.010	0.7875	20.002	0.0005	0.013	0.00035	0.009	0.7871	19.992	0.7866	19.980	0.00035	0.009	0.00045	0.011
05	0.9843	25	0.9839	24.990	0.9848	25.014	0.9844	25.004	0.0005	0.013	0.00035	0.009	0.9840	24.994	0.9835	24.981	0.00035	0.009	0.00045	0.011
06	1.1811	30	1.1807	29.990	1.1816	30.010	1.1812	30.002	0.0005	0.013	0.00035	0.009	1.1808	29.992	1.1803	29.980	0.00035	0.009	0.00045	0.011
07	1.3780	35	1.3775	34.987	1.3785	35.014	1.3781	35.004	0.0006	0.014	0.00045	0.011	1.3776	34.991	1.3770	34.976	0.00045	0.011	0.00055	0.014
08	1.5748	40	1.5743	39.987	1.5753	40.013	1.5749	40.002	0.0006	0.014	0.00045	0.011	1.5744	39.990	1.5739	39.975	0.00045	0.011	0.00055	0.014
09	1.7717	45	1.7712	44.987	1.7722	45.014	1.7718	45.004	0.0006	0.014	0.00045	0.011	1.7713	44.991	1.7707	44.976	0.00045	0.011	0.00055	0.014
10	1.9685	50	1.9680	49.987	1.9690	50.013	1.9686	50.002	0.0006	0.014	0.00045	0.011	1.9681	49.990	1.9375	49.974	0.00045	0.011	0.00055	0.014
11	2.1654	55	2.1648	54.985	2.1660	55.016	2.1655	55.004	0.0007	0.017	0.00055	0.014	2.1650	54.991	2.1643	54.973	0.00045	0.011	0.00055	0.014
12	2.3622	60	2.3616	59.985	2.3628	60.015	2.3623	60.002	0.0007	0.017	0.00055	0.014	2.3618	59.990	2.3611	59.972	0.00045	0.011	0.00055	0.014
13	2.5591	65	2.5585	64.985	2.5597	65.016	2.5592	65.004	0.0007	0.017	0.00055	0.014	2.5587	64.991	2.5580	64.973	0.00045	0.011	0.00055	0.014
14	2.7559	70	2.7553	69.985	2.7565	70.015	2.7560	70.002	0.0007	0.017	0.00055	0.014	2.7555	69.990	2.7548	69.972	0.00045	0.011	0.00055	0.014
15	2.9528	75	2.9522	74.985	2.9534	75.016	2.9529	75.004	0.0007	0.017	0.00055	0.014	2.9524	74.991	2.9517	74.973	0.00045	0.011	0.00055	0.014
16	3.1496	80	3.1490	79.985	3.1502	80.015	3.1497	80.002	0.0007	0.017	0.00055	0.014	3.1492	79.990	3.1485	79.972	0.00045	0.011	0.00055	0.014
17	3.3465	85	3.3457	84.980	3.3472	85.019	3.3466	85.004	0.0008	0.020	0.00065	0.017	3.3460	84.988	3.3452	84.968	0.00050	0.013	0.00065	0.017
18	3.5433	90	3.5425	89.980	3.5440	90.018	3.5434	90.002	0.0008	0.020	0.00065	0.017	3.5428	89.987	3.5420	89.967	0.00050	0.013	0.00065	0.017
19	3.7402	95	3.7394	94.980	3.7409	95.019	3.7403	95.004	0.0008	0.020	0.00065	0.017	3.7397	94.988	3.7389	94.968	0.00050	0.013	0.00065	0.017
20	3.9370	100	3.9362	99.980	3.9377	100.018	3.9371	100.002	0.0008	0.020	0.00065	0.017	3.9365	99.987	3.9357	99.967	0.00050	0.013	0.00065	0.017

SHAFT AND HOUSING FITS

Radial Ball Bearing

Housing Fits, ABEC-1, ABEC-3, 9100, 9300 SERIES

NOTE: These tables are to be used for applications where only one ring (either inner or outer) has an interference fit with its shaft and housing

Basic Bearing Number	Housing Rotating, Load Stationary or Housing Stationary, Load Rotating								Housing Rotating, Load Stationary or Housing Stationary, Load Rotating							
	Housing Bore min.		Housing Bore max.		(mean fit) loose ABEC-1		(mean fit) loose ABEC-3		Housing Bore min.		Housing Bore max.		(mean fit) tight ABEC-1		(mean fit) tight ABEC-3	
	in.	mm	in.	mm	in.	mm	in.	mm	in.	mm	in.	mm	in.	mm	in.	mm
9100	1.0236	25.999	1.0241	26.012	0.00045	0.011	0.00040	0.010	1.0228	25.979	1.0236	25.999	0.00020	0.005	0.00025	0.006
9101,9302	1.1024	28.001	1.1029	28.014	0.00045	0.011	0.00040	0.010	1.1016	27.981	1.1024	28.001	0.00020	0.005	0.00025	0.006
9303	1.1811	30.000	1.1816	30.013	0.00045	0.011	0.00040	0.010	1.1803	29.980	1.1811	30.000	0.00020	0.005	0.00025	0.006
9102	1.2598	31.999	1.2604	32.014	0.00055	0.014	0.00045	0.011	1.2588	31.974	1.2598	31.999	0.00025	0.006	0.00035	0.009
9103	1.3780	35.001	1.3786	35.016	0.00055	0.014	0.00045	0.011	1.3770	34.976	1.378	35.001	0.00025	0.006	0.00035	0.009
9304	1.4567	37.000	1.4573	37.015	0.00055	0.014	0.00045	0.011	1.4557	36.975	1.4567	37.000	0.00025	0.006	0.00035	0.009
9104,9305	1.6535	41.999	1.6541	42.014	0.00055	0.014	0.00045	0.011	1.6525	41.974	1.6535	41.999	0.00025	0.006	0.00035	0.009
9105,9306	1.8504	47.000	1.8510	47.015	0.00055	0.014	0.00045	0.011	1.8494	46.975	1.8504	47.000	0.00025	0.006	0.00035	0.009
9106,9307	2.1654	55.001	2.1661	55.019	0.00060	0.015	0.00055	0.014	2.1642	54.971	2.1654	55.001	0.00035	0.009	0.00040	0.010
9107,9308	2.4409	61.999	2.4416	62.017	0.00060	0.015	0.00055	0.014	2.4397	61.968	2.4409	61.999	0.00030	0.009	0.00040	0.010
9108	2.6772	68.001	2.6779	68.019	0.00060	0.015	0.00055	0.014	2.6760	67.970	2.6772	68.001	0.00030	0.009	0.00040	0.010
9310	2.8346	71.999	2.8353	72.017	0.00060	0.015	0.00055	0.014	2.8334	71.968	2.8346	71.999	0.00030	0.009	0.00040	0.010
9109	2.9528	75.001	2.9535	75.019	0.00060	0.015	0.00055	0.014	2.9516	74.971	2.9528	75.001	0.00030	0.009	0.00040	0.010
9110	3.1496	80.000	3.1503	80.018	0.00060	0.015	0.00055	0.014	3.1484	79.969	3.1496	80.000	0.00030	0.009	0.00040	0.010
9312	3.3465	85.001	3.3474	85.024	0.00080	0.019	0.00065	0.017	3.3451	84.966	3.3465	85.001	0.00040	0.010	0.00050	0.013
9111	3.5433	90.000	3.5442	90.023	0.00080	0.019	0.00065	0.017	3.5419	89.964	3.5433	90.000	0.00040	0.010	0.00050	0.013
9112	3.7402	95.001	3.7411	120.424	0.00080	0.019	0.00065	0.017	3.7388	94.965	3.7402	95.001	0.00040	0.010	0.00050	0.013
9113	3.9370	100.000	3.9379	100.023	0.00080	0.019	0.00065	0.017	3.9356	99.964	3.9370	100.000	0.00040	0.010	0.00050	0.013
9114	4.3307	110.000	4.3316	110.023	0.00080	0.019	0.00065	0.017	4.3293	109.964	4.3307	110.000	0.00040	0.010	0.00050	0.013
9115	4.5276	115.001	4.5285	115.024	0.00080	0.019	0.00065	0.017	4.5262	114.965	4.5276	115.001	0.00040	0.010	0.00050	0.013
9117	5.1181	130.000	5.1191	130.025	0.00090	0.023	0.00075	0.019	5.1165	129.959	5.1181	130.000	0.00040	0.010	0.00055	0.014
9118	5.5118	140.000	5.5128	140.250	0.00090	0.023	0.00075	0.019	5.5102	139.959	5.5118	140.000	0.00040	0.010	0.00055	0.014
9120	5.9055	150.000	5.9065	150.025	0.00090	0.023	0.00075	0.019	5.9039	149.959	5.9055	150.000	0.00040	0.010	0.00055	0.014

RADIAL BALL BEARINGS

RBC Airframe Control Needle Roller Bearings

PRODUCT NOMENCLATURE	76
Engineering Section for Needle Track Rollers and Stud-type Track Rollers	77-82
AIRFRAME CONTROL	
NEEDLE TRACK ROLLERS AND STUD-TYPE TRACK ROLLERS	
Single/Double Row Sealed Series	
MS21438 ATF Series: Single Row, Sealed	83
MS21439 ATL Series: Double Row, Sealed	84
AeroCres® Reduced Maintenance Track Rollers	85-86
AS5927 ATF-T8 Series: Single Row, Sealed	87
AS5928 ATL-T8 Series: Double Row, Sealed	88
Single/Double Row, Heavy Loads, Slow Speeds Series	
MS24465 NBF Series: Single Row, Heavy Loads, Low Speeds . . .	89
MS24466 NBL Series: Double Row, Heavy Loads, Low Speeds . .	90

Single Row, Outer Supported by Housing Series	
MS24461 NBC Series: Outer Supported by Housing	91-92
Single/Double Row Self-aligning Series	
MS24463 NBE Series: Single Row, Self-aligning	93
MS24464 NBK Series: Double Row, Self-aligning	94
Single Row, Minimum Section Series	
MS24462 NCC Series: Minimum Section	95-96
Stud-type Track Roller Series	
MS21432 HRS/HRSC Series: Stud-type Track Rollers	97-98
AeroCres® Fracture-tough Airframe Products	
AS5929 AHRSC/AAHRSC Series: Stud-type Track Rollers .	101-102
Special Designs	103

GENERAL FEATURES AND TECHNICAL SPECIFICATIONS

Washers & Seals

The washers are fastened to the inner ring and contain part specific identification. Improved one piece copolymer design seals provides superior protection and lubricant retention.

Inner Ring

Inner rings may contain lubrication grooves and lube holes to allow the bearing to be relubricated in service.

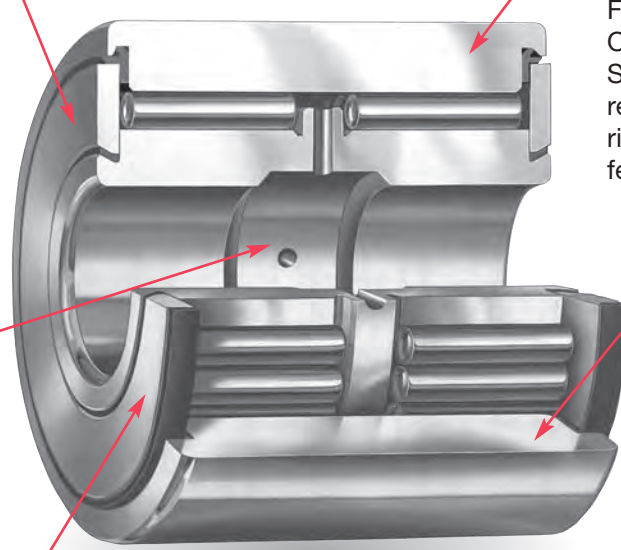

Outer Ring

The outer ring may contain a crown (ATF type) or remain flat. For corrosion protection the O.D. may be chrome plated. Some bearings may contain a relubrication feature in the outer ring. Additionally, a self-aligning feature is optional.

Materials

Various materials are used for track roller construction such as 52100, 440C, or AeroCres®. AeroCres® is an internally developed, highly corrosion resistant steel. See our AeroCres® "Featured Product" pages (85-86) for more material information.

Construction

A non-separable unit, consisting of an inner ring, needle rollers, outer ring, washers and seals. The outer rings are very thick to withstand heavy rolling loads. For extremely high loads, two roller paths may be chosen (as pictured). All exposed surfaces (except bore) may be cadmium plated for galvanic corrosion resistance.

AIRFRAME CONTROL
NEEDLE ROLLER
BEARINGS

AIRFRAME CONTROL NEEDLE ROLLER BEARINGS

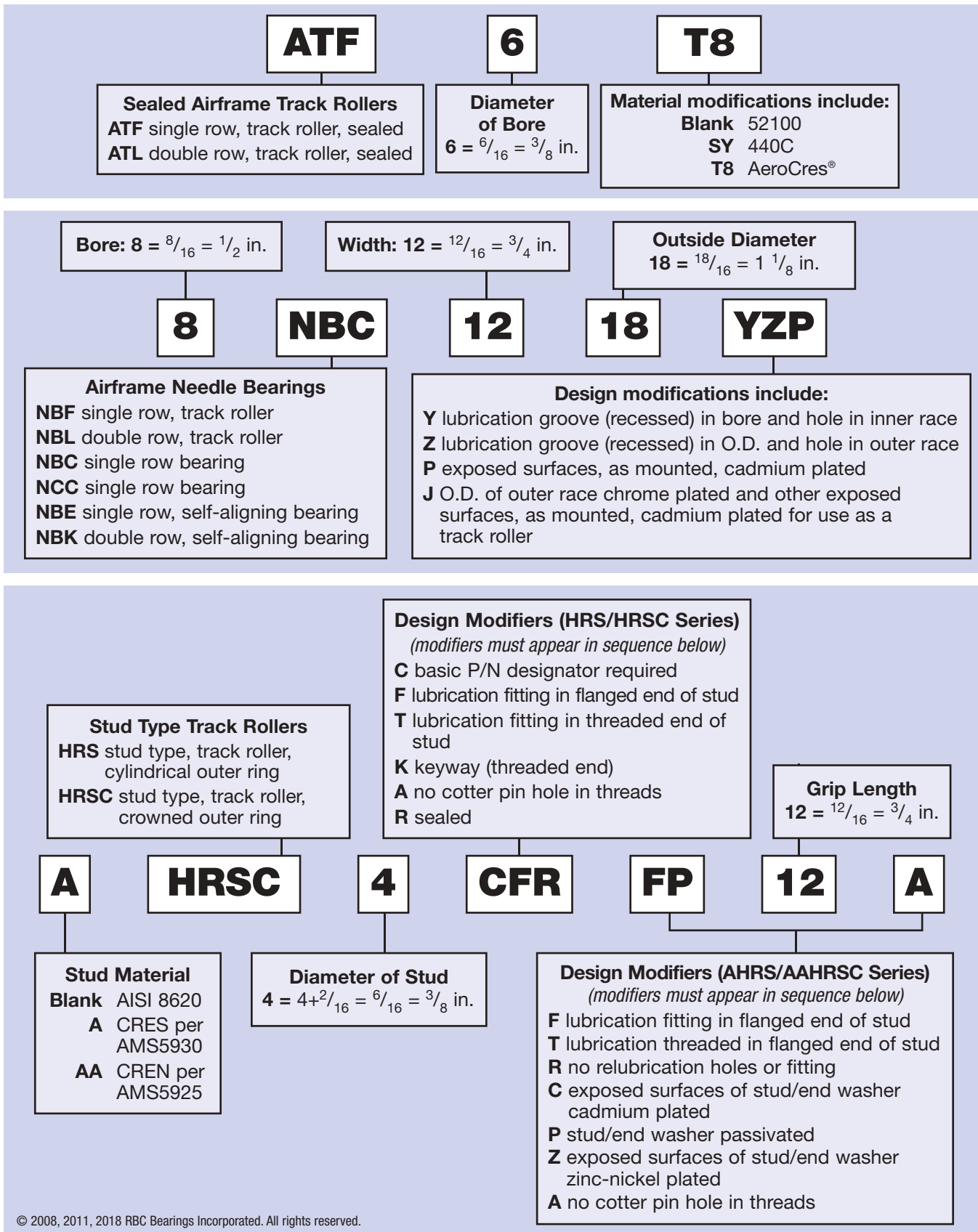

© 2008, 2011, 2018 RBC Bearings Incorporated. All rights reserved.

AIRFRAME CONTROL NEEDLE ROLLER BEARINGS

INTRODUCTION

The bearings described in this section of the catalog have been designed to meet the specific needs of the airframe industry. Most of these bearings conform to military, and national standards current at the time of publication of the catalog.

Before selecting specific airframe needle roller bearings, the Engineering Section should be reviewed for detailed information concerning:

- Bearing type
- Material section
- Load ratings/life calculations
- Application criteria

IDENTIFICATION

The code letters **ATF** denote a sealed airframe track roller bearing with a single row of needle rollers, internal thrust washers, and a crowned O.D.

The code letters **ATL** denote a sealed airframe track roller bearing with two rows of needle rollers, and internal thrust washers.

The code letters **NBF** denote an airframe track roller bearing with a single row of needle rollers.

The code letters **NBL** denote an airframe track roller bearing with two rows of needle rollers.

The code letters **NBC** denote an airframe bearing with a single row of needle rollers. Type **NBC** bearings must be mounted in supporting housings.

The code letters **NCC** denote an airframe bearing with a single row of needles and a drawn shell that must be mounted in supporting housings.

The code letters **NBE** denote a self-aligning airframe needle roller bearing with a single row of needle rollers. The code letters **NBK** denote an airframe bearing similar to type **NBE** but with two rows of needle rollers. Both types **NBE** and **NBK** bearings must be mounted in supporting housings.

The code letters **HRS** denote a stud type airframe track roller bearing with a single row of needle rollers. This bearing can be sealed.

The code letters **HRSC** denote a sealed, stud type airframe track roller bearing with a single row of needle rollers and a crowned O.D.

All of these various types of airframe needle roller bearings meet the requirements of U.S. Military Specification AS39901 and the following military specifications:

bearing type	military specification	bearing type	military specification
ATF	SAE AS21438	NBC	SAE AS24461
ATL	SAE AS21439	NBE	SAE AS24463
NBF	SAE AS24465	NBK	SAE AS24464
NBL	SAE AS24466	HRS	SAE AS21432
NCC	SAE AS24462	HRSC	SAE AS21447
ATF-T8	SAE AS5927	AAHRSC	SAE AS5929A
ATL-T8	SAE AS5928	AHRSC	SAE AS5929B

RBC airframe needle roller bearings are permanently marked with the bearing designation (which includes the bearing type code) and the military specification number as listed in the tabular pages.

Since these bearings are often supplied prelubricated to meet special requirements, the airframe manufacturer's parts list or another reliable source should always be consulted when ordering bearings to ensure the correct lubricant is used.

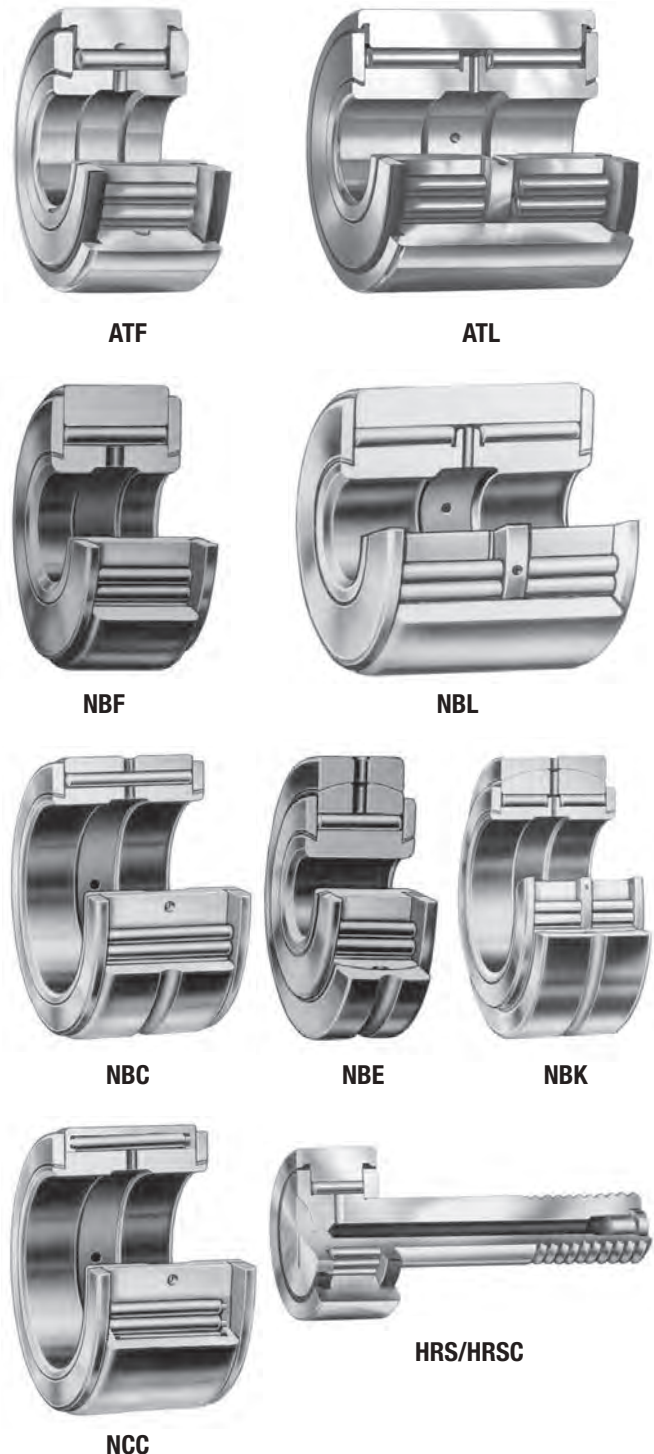

AIRFRAME CONTROL NEEDLE ROLLER BEARINGS

BEARING TYPE SELECTION

Types **ATF** and **NBF** bearings are designed for use as track rollers to withstand heavy rolling loads. If their full radial capacity is to be realized, they should be mounted on high strength bolts. Also, the initial alignment between the bearing centerline and the surface of the track should be very good. To prevent deflections under load that would cause poor load distribution along the length of the rolling elements, the bearing should be straddle-mounted in a rigid housing, and the track should be rigidly supported.

Types **ATF** and **NBF** bearings are sometimes cantilever mounted on high strength bolts. In this case, the deflection of the supporting member, the mounting bolt and the track should be balanced as carefully as possible to improve the load distribution. If this cannot be accomplished, the track should be crowned, or preference should be given to the type **ATF** which has a crowned outer ring.

Types **ATL** and **NBL** bearings are intended to carry rolling loads which are greater than those for which types **ATF** and **NBF** are designed. Since types **ATL** and **NBL** bearings are quite long, it is important to mount them on high strength shafts or bolts. The alignment between the bearing axis and the track is even more critical than with types **ATF** and **NBF**. Types **ATL** and **NBL** bearings must be straddle-mounted.

Types **ATF** and **ATL** bearings have seal/thrust washers which increase the life in case the bearings are infrequently relubricated.

Type **NBC** bearings are designed primarily to carry heavy static loads, or moderate loads under oscillation or slow rotation. This type of bearing can tolerate incidental thrust loads only through the outer ring when the retaining washers are properly backed up.

Type **NBC** bearings must be supported by housings and mounted on high strength shafts if their inherent load ratings are to be realized. Initial alignment must be good and operating deflections must be minimized to ensure uniform load distribution along the length of the rolling elements.

Type **NCC** bearings are designed primarily to carry moderate loads under oscillation or slow rotation. This type of bearing should not be used in applications that require thrust capability. The **NCC** bearings are the minimal cross-section available in standard airframe needle bearings.

Type **NCC** bearings must be supported by housings and mounted on high strength shafts if their inherent load ratings are to be realized. Initial alignment must be good and operating deflections must be minimal to ensure uniform load distribution along the length of the rolling elements.

Types **NBE** and **NBK** bearings are also used primarily for heavy static loads, and will also handle oscillation or slow rotation. They are designed to accommodate only minor locational thrust loads. Types **NBE** and **NBK** bearings, like type **NBC**, must be supported by housings and mounted on high strength shafts if their inherent load ratings are to be realized.

Types **NBE** and **NBK** bearings are of larger cross-section than the type **NBC**, and, if properly mounted, will tolerate misalignment up to $\pm 5^\circ$. They are **not** designed to self-align under heavy loads. If alignment must be accommodated while the bearings are highly loaded, the torque required to overcome the friction at the spherical surfaces may overload the rolling elements.

Types **HRSC** and **HRS** bearings are designed for use as track rollers to carry moderate rolling loads. The bearings have an integral stud, which eliminates the need for a separate mounting bolt.

Types **HRSC** and **HRS** are to be cantilever mounted. Under load, the supporting member, the bearing stud, and the track may deflect to produce misalignment between the bearing and the track. These deflections should be carefully balanced to minimize the effective misalignment, and improve the load distribution. Where misalignment is a factor, preference should be given to type **HRSC**, which has a crowned outer ring.

CONSTRUCTION

All airframe needle roller bearings incorporate materials, protective finishes, and relubrication facilities required for airframe service.

MATERIALS

The outer rings, inner rings, and self-aligning rings are made of high carbon chrome steel, hardened, and precision ground.

Studs are made of bearing quality steel, heat treated to 60 HRC minimum in the raceway area and 36-44 HRC in the shank and thread areas.

The rollers are made of high carbon chrome steel, through hardened, precision ground, and lapped.

The retaining washers are made of high carbon steel, and hardened. The bearing components may also be available in a variety of stainless steels. These specialty steels have been developed for use in extremely corrosive environments and may be available upon request.

The **NCC** series thin shell is made from low carbon steel that is case hardened. The retaining washers are soft low carbon steel.

RELUBRICATION FEATURES

The inner rings of types **ATF, ATL, NBF, NCC,** and **NBL** bearings are provided with relubrication grooves and holes. Relubrication features are omitted from the outer rings since they would be undesirable in track roller bearings or thin shells.

Types **HRSC** and **HRS** can be provided with lubrication fittings in the flanged end or threaded end of the stud, or with no relubrication provision.

Grooves are provided in the bore and outside diameters of the larger types **NBC, NBE,** and **NBK** bearings with drilled holes leading to the needle roller complement to allow relubrication through the housing or the shaft. The smaller sizes, as noted in the tabular pages, do not have relubrication grooves and holes in their inner rings since the mounting shafts would be considerably weakened by the required drilled lubrication holes.

The right is reserved to change material specifications or to revise designs without notice.

PROTECTIVE FINISHES

Outer rings of types **ATF, ATL, NBF, NBL, HRSC,** and **HRS** bearings, which are subjected to heavy rolling loads, may be chrome plated on the exposed surfaces for corrosion protection. Outer rings of types **ATF-T8, ATL-T8, AHRSC,** and **AAHRSC** bearings are passivated for additional corrosion protection. The other external surfaces of the bearings (where applicable) are cadmium plated, zinc-nickel plated, or passivated.

Types **NBC, NCC, NBE,** and **NBK** bearings are cadmium or zinc-nickel plated on all external surfaces, except the bore of the inner ring.

LOAD RATINGS

The **limit** load ratings listed in this catalog are the maximum radial loads that can be applied without impairing the subsequent function of the bearing in airframe applications.

The **ultimate (static fracture)** load ratings are not less than 1.5 times the limit load rating.

For types **ATF, ATL, NBF,** and **NBL** bearings, the ultimate load rating assumes an unsupported outer ring. Therefore, the **limit** load ratings listed on the tabular pages correspond to 2/3 of the **limit** load ratings of the fully supported bearing, or 4/9 ASC. The **ultimate (static fracture)** load ratings are not less than 1.5 times the **limit** load rating (2/3 ASC).

In addition to heavy static radial loads, types **ATF, ATL, NBF,** and **NBL** bearings must withstand heavy rolling loads under slow rotation. The **capacity as a track roller** is the load the bearing will carry as a track roller for an L10 life of 20,000 revolutions. The **capacity as a track roller** is based on 1/3 Aircraft Static Capacity (ASC).

To calculate the L_{10} life, in revolutions, of a type **ATF, ATL, NBF,** and **NBL** bearing, the following formula should be used:

$$TL = \frac{20000}{\sum T_i \left(\frac{P_i}{CTR} \right)^6 + \sum t_i \left(\frac{p_i}{CTR} \right)^{10/3}}$$

Where TL = total life (L_{10})

CTR = capacity as a track roller

P_i = loads greater than CTR

p_i = loads less than CTR

T_i = fraction of total revolutions at load P_i

t_i = fraction of total revolutions at load p_i

Under no circumstances should the applied load exceed the limit load rating.

In the case of types **NBC, NCC, NBE, and NBK** bearings, the ultimate load ratings correspond to the Aircraft Static Capacity. The limit load rating listed is 2/3 of the ultimate load rating.

Types **NBC, NCC, NBE, and NBK** bearings are generally applied where they carry only moderate loads while oscillating or rotating slowly, but they are expected to carry heavy static radial loads or shock loads. For this reason the basic (dynamic) load ratings are not listed. If the basic load ratings are required for specific bearings, please consult an RBC Aerospace Bearings sales engineer.

If types **NBE** and **NBK** bearings are required to carry more than light loads while self-aligning, the torque required to overcome the friction between the spherical surfaces may add substantially to the radial loads on the rolling elements. Under such circumstances, please consult an RBC Aerospace Bearings sales engineer.

Type **HRS** and **HRSC** track roller bearings have heat treated studs as such working loads are not limited by stud strength. The limit load ratings listed on the tabular pages correspond to 2/3 of ASC. The **ultimate (static fracture)** load ratings are not less than 1.5 times the limit load rating (ASC). The capacity as a track roller for 20,000 revolutions L10 life is $1/3 \cdot ASC$.

TRACK CAPACITY

When applying types **ATF, ATL, NBF, NBL, HRS, and HRSC** track roller bearings, the compressive strength of the track material is often the critical design factor for the application. Where listed, the **track capacities** are based on a track hardness equivalent to 40 HRC. For other hardness values multiply the **track capacity** listed on the tabular pages by the appropriate factor selected from Table 1.

When using track materials with high hardness, it must be remembered that the load applied to a bearing should not exceed the limit load for that bearing.

TABLE 1

Track Hardness	Track Capacity Factor
HRC	
20	0.4
25	0.5
30	0.6
35	0.8
40	1.0
45	1.4
50	1.9
55	2.6
58	3.2

TEMPERATURE

The unsealed airframe needle bearings listed herein can be operated at temperatures up to 400°F (200°C) if a suitable lubricant is used. Subjecting these bearings to higher temperatures will result in a loss of capacity, which depends upon the length of time that the bearings are exposed to the higher temperature. Temperature differential between bearing parts should be watched to prevent take-up of internal clearance due to differential expansion.

The operating temperature of the sealed bearings is limited by the seal material and should not exceed 250°F (120°C).

The data herein permit tentative bearing selection, but before the application is finalized, please consult an RBC Aerospace Bearings sales engineer.

SPECIAL BEARINGS

RBC supplies airframe bearings, in addition to types **ATF** and **ATL**, which are sealed to help retain lubricants and exclude foreign matter. For superior performance, the sealing arrangement has been designed to be capable of withstanding a pressure of 400 bar. We also supply bearings with special configurations, materials, protective finishes, tolerance, and lubricants. Please consult an RBC Aerospace Bearings sales engineer.

SPEED

Airframe needle roller bearings are intended for use in low speed, high load applications. The bearing speed should not exceed 100 RPM. Speeds in excess of 100 RPM will greatly reduce the bearing life.

LUBRICATION

The most common greases used in aircraft track roller and cam follower applications are MIL-PRF-23827 TYPE 1 and MIL-PRF-81322 grease. Either grease is available for catalog items. If a specific grease is preferred, then specify it upon placing the order.

Military Spec. No.	MIL-PRF-23827 TYPE 1	MIL-PRF-81322
Grease Name	Aeroshell 33®	Mobil 28®
Operating Temp.	-65°F to +250°F -53°C to +120°C	-60°F to +350°F -51°C to +177°C

OPERATING TEMPERATURES FOR BEARING COMPONENT MATERIALS

CHART 1 — RINGS AND ROLLERS

Material	Approximate Chemical Analysis - %	Temp. °F	Minimum Hardness Rc	Temperature Range (°F / °C)											
				-100°F -73°C	-65°F -54°C	0°F -17°C	100°F 38°C	200°F 93°C	300°F 149°C	350°F 177°C	400°F 204°C	500°F 260°C	600°F 316°C	700°F 371°C	800°F 427°C
52100 per AMS6440	1C 1.5Cr .35Mn	70	58	Standard dimensional stabilization											
Carburizing steel per AISI 8620	.2C .5Cr .80Mn .20Mo .55Ni	70	58	Frequently used to achieve extra ductility for cam follower studs											
440C CRES per AMS5880	1C 18Cr	70	58	Excellent corrosion resistance											
Pyroware 675 per AMS5930	.08C .75Mn 13Cr 2.5Ni 6Co 2Mo .60V	70	58	Superior corrosion resistance and ductility for cam follower studs											
Corrosion resistant steel per AMS5655 with proprietary heat treat process	.22C 12Cr .75Ni 1Mo 1W .25V	70	58	Superior corrosion resistance and fracture toughness											
Heat stabilized 440C CRES per AMS5880	1C 18Cr	70 450 600	58 55 52	Heat stabilized for maximum hardness at high temperatures. Good oxidation resistance at higher temperatures. Note load capacity drops off more rapidly at higher temperatures than M50 shown below, which should be considered if loads are high.											
M50 steel per AMS6490 or AMS6491	.80C 4Cr 4Mo 1V	70 450 600	60 59 57	Recommended where stable high hardness at elevated temperatures is required.											
Corrosion resistant XD15NW CREN per AMS5925	.4C 15.5Cr 1.8Mo .2N .3V	70	58	Excellent high corrosion, wear, and fatigue resistance for cam follower studs.											

Bearings have been made of special materials such as Haynes Alloy 25, BG42, etc., for operation at temperatures above 800°F (427°C).

Aeroshell 33® is a registered trademark of Shell Corporation.

Mobil 28® is a registered trademark of Exxon Mobil Corporation.

© 2008, 2011, 2018 RBC Bearings Incorporated. All rights reserved.

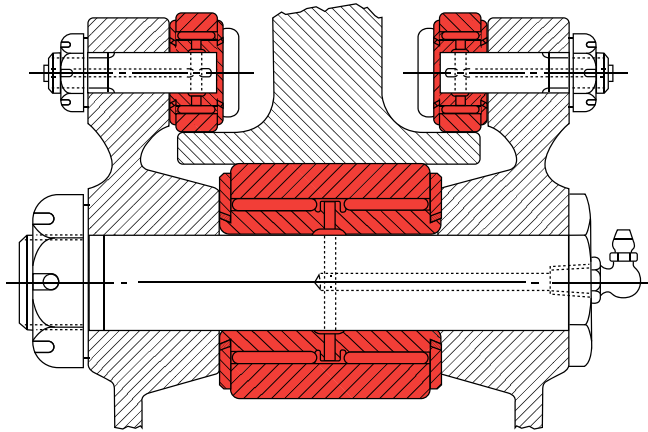

FLAP TRACK

Airframe needle roller bearings serve where weight and space are vital factors. They give high capacity anti-friction performance on flap tracks of large high-speed, high-altitude aircraft.

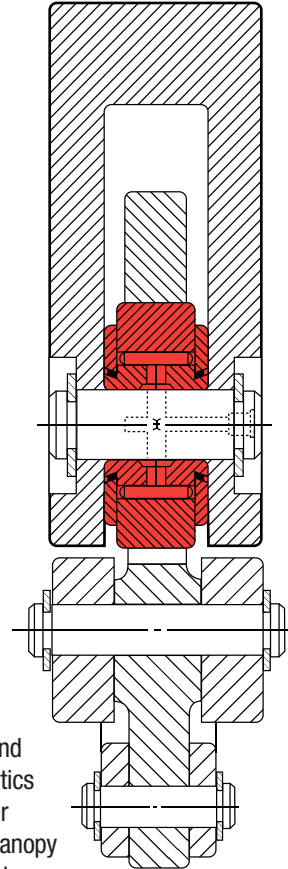

CANOPY

The high capacity and anti-friction characteristics of airframe needle roller bearings are ideal for canopy lock rolls where failure to operate may be fatal.

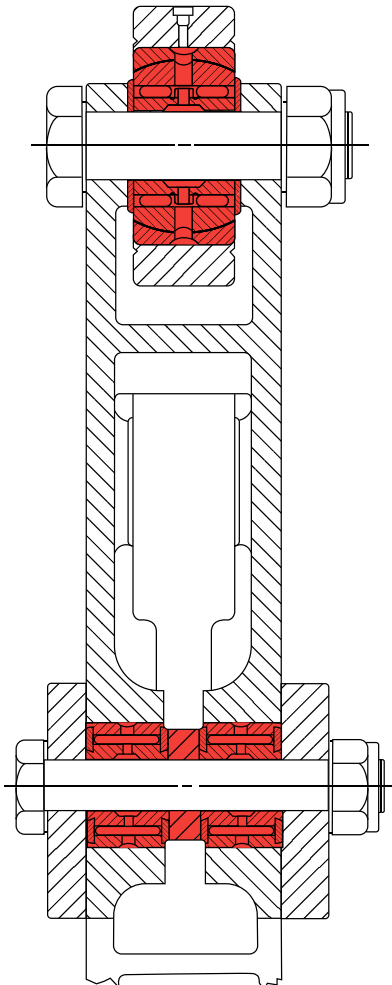

BELL CRANK

The small size and light weight of the airframe needle roller bearing permits reduction in material required in surrounding parts.

The high capacity offers superior anti-friction operation under severe service conditions.

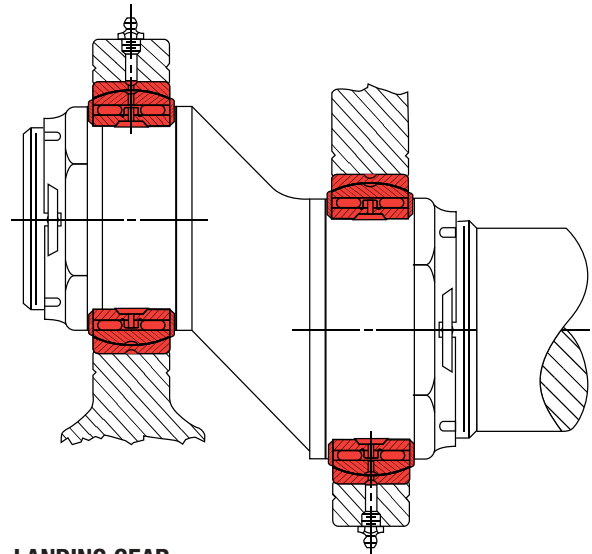

LANDING GEAR

The high static capacity of the airframe needle roller bearing is an important factor in meeting the rugged impact loads found in aircraft landing gears.

Small size and simple lubrication contribute to lighter assemblies and long service life.

AIRFRAME CONTROL NEEDLE ROLLER BEARINGS

CONSTRUCTION

This is a non-separable unit, comprising an inner ring, needle rollers, retaining washers, seal/thrust washers, and an extra-thick outer ring to withstand heavy rolling loads. The end washers are fastened to the inner ring. Type ATF has a single row of rollers and type ATL has two rows of rollers. The outer ring of type ATF bearing is crowned.

The seals on the ATF and ATL bearings are located in counterbores of the outer ring and seal against the O.D. of the end washers, providing a good retention of lubricant and exclusion of foreign material. Seal/thrust washers, made of a self-lubricating resin material, separate the steel thrust surfaces, extending the life of lubricant and bearing.

Grooves and holes for relubrication are provided in the inner ring only, since the outer ring must serve as a roller. Type ATF has a groove in the bore of the outer ring for storage of additional lubricant. For protection from corrosion under heavy rolling loads, the O.D. of the bearing is chrome plated. Other exposed surfaces, as mounted, are cadmium or zinc-nickel plated. Inner rings are oxidized.

DIMENSIONS

Types ATF and ATL are manufactured to inch nominal dimensions. Metric dimensions shown are for the convenience of the user, and the controlling dimensions are in inches. Dimensions listed are for the finished bearing after plating. The shaft diameter dimensions necessary to mount these bearings properly are listed on the facing page.

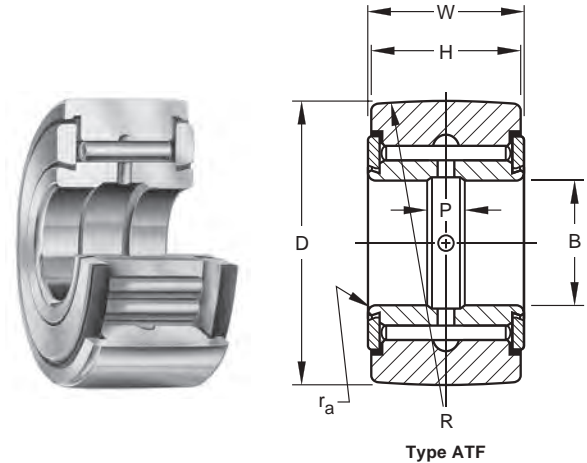

SPECIFICATIONS AND ORDERING INFORMATION

BEARING DIMENSIONS

Bearing Designation	MS21438 MS21439 Dash No.	B* Bore		D* O.D.		W Widths		H		r _a § Shaft Fillet (max.)	P Inner Ring Groove Width (ref.)		R Crown Radius (ref.)		
		+0.000	+0.000	+0.001	+0.025	+0.000	+0.000	+0.000	+0.000		in.	mm	in.	mm	
		-0.0007	-0.018	-0.001	-0.025	-0.010	-0.25	-0.010	-0.25						
		in.	mm	in.	mm	in.	mm	in.	mm						
ATF-3	MS21438-103	0.1900	4.826	0.7500	19.05	0.312	7.92	0.280	7.11	0.022	0.56	0.094	2.39	11	279
ATF-4	MS21438-104	0.2500	6.350	0.8750	22.23	0.375	9.53	0.345	8.76	0.022	0.56	0.125	3.18	11	279
ATF-6	MS21438-106	0.3750	9.525	1.0625	26.99	0.500	12.70	0.455	11.56	0.022	0.56	0.188	4.78	11	279
ATF-8	MS21438-108	0.5000	12.700	1.3125	33.34	0.625	15.88	0.580	14.73	0.032	0.81	0.188	4.78	13	330
ATF-10	MS21438-110	0.6250	15.875	1.5000	38.10	0.750	19.05	0.705	17.91	0.032	0.81	0.250	6.35	18	457
ATF-12	MS21438-112	0.7500	19.050	1.7500	44.45	1.000	25.40	0.950	24.13	0.032	0.81	0.250	6.35	31	787
ATF-14	MS21438-114	0.8750	22.225	2.0000	50.80	1.125	28.58	1.075	27.31	0.032	0.81	0.250	6.35	36	914
ATF-16	MS21438-116	1.0000	25.400	2.2500	57.15	1.125	28.58	1.075	27.31	0.032	0.81	0.250	6.35	27	686
ATF-20	MS21438-120	1.2500	31.750	2.5000	63.50	1.250	31.75	1.200	30.48	0.032	0.81	0.375	9.53	61	1549
ATF-24	MS21438-124	1.5000	38.100	3.0000	76.20	1.500	38.10	1.440	36.58	0.032	0.81	0.375	9.53	61	1549
ATF-28	MS21438-128	1.7500	44.450	3.4375	87.31	1.500	38.10	1.440	36.58	0.032	0.81	0.375	9.53	61	1549
ATF-32	MS21438-132	2.0000	50.800	3.8750	98.43	1.500	38.10	1.440	36.58	0.032	0.81	0.375	9.53	61	1549
ATL-4	MS21439-104	0.2500	6.350	0.8750	22.23	0.750	19.05	0.710	18.03	0.022	0.56	0.188	4.78	-	-
ATL-6	MS21439-106	0.3750	9.525	1.1250	28.58	1.000	25.40	0.940	23.88	0.022	0.56	0.188	4.78	-	-
ATL-8	MS21439-108	0.5000	12.700	1.3750	34.93	1.250	31.75	1.190	30.23	0.032	0.81	0.250	6.35	-	-
ATL-10	MS21439-110	0.6250	15.875	1.6250	41.28	1.500	38.10	1.440	36.58	0.032	0.81	0.375	9.53	-	-
ATL-12	MS21439-112	0.7500	19.050	1.8750	47.63	1.750	44.45	1.690	42.93	0.032	0.81	0.375	9.53	-	-
ATL-14	MS21439-114	0.8750	22.225	2.1250	53.98	2.000	50.80	1.940	49.28	0.032	0.81	0.375	9.53	-	-
ATL-16	MS21439-116	1.0000	25.400	2.3750	60.33	2.250	57.15	2.190	55.63	0.032	0.81	0.375	9.53	-	-
ATL-20	MS21439-120	1.2500	31.750	2.7500	69.85	2.500	63.50	2.440	61.98	0.032	0.81	0.375	9.53	-	-
ATL-24	MS21439-124	1.5000	38.100	3.0000	76.20	2.750	69.85	2.690	68.33	0.032	0.81	0.375	9.53	-	-
ATL-28	MS21439-128	1.7500	44.450	3.4375	87.31	3.000	76.20	2.940	74.68	0.032	0.81	0.375	9.53	-	-
ATL-32	MS21439-132	2.0000	50.800	3.8750	98.43	3.000	76.20	2.940	74.68	0.032	0.81	0.375	9.53	3	-

* Bore and O.D. tolerance limits correspond to the single mean diameter (the arithmetical mean of the largest and smallest diameters in a single radial plane).

§ Equal to minimum bearing chamfers.

¶ Tolerance for width C for ATL series is +0.000 -0.005 in.

MOUNTING

Types ATF and ATL bearings are designed for heavy rolling loads. The type ATF bearing is usually clevis mounted or cantilever mounted on a high strength shaft or bolt. The type ATL bearing must be straddle-mounted on a high strength shaft or bolt.

The end washers are fastened to the inner ring in a manner only to maintain the integrity of the assembly while handling and installing the bearing. Therefore, when mounted they should be firmly backed up by washers or other clamping surfaces that are flat and square with the shaft center line. To provide sufficient washer support, the outside diameter of the clamping surfaces should be at least as large as the minimum clamping diameter (d_a) listed below.

LOAD RATINGS

Bearings are constructed to provide maximum capacity under rolling loads.

The limit load ratings (also called “allowable working load ratings”) of the bearings are listed below. The ultimate load ratings are not less than 1.5 times the limit load ratings. The ultimate load ratings correspond to 2/3 of the Aircraft Static Capacity ratings.

Load ratings are given in pounds-force:
 1 lbf = 0.454 kgf = 4.448 N

Before final bearing selection is made, please consult an RBC Aerospace Bearings sales engineer.

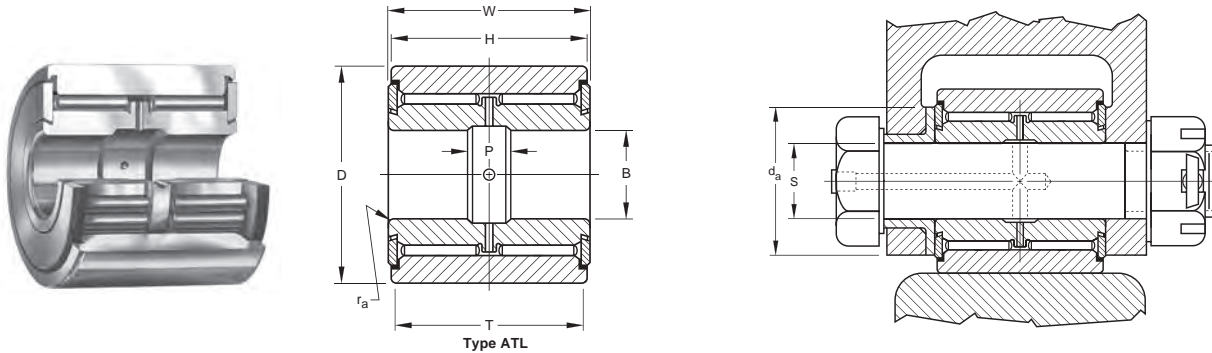

SPECIFICATIONS AND ORDERING INFORMATION

MOUNTING DIMENSIONS

T Track Contact Width (minimum)	Weight (approx.)		S Shaft Diameters				d_a Clamping Diameter (minimum)	Clamping Force (max.)	Bearing Capacity						
			Transition Fits (loose fits)		Transition Fits (tight range)				as a Track Roller (CTR)		Limit Load Rating				
in. mm	lbs	kgs	in.	in.	in.	in.	in.	mm	lbf	N	lbf	N	lbf	N	
-	-	0.030	0.01	0.1894	0.1889	0.1902	0.1897	0.438	11.13	480	2100	900	4000	1200	5300
-	-	0.051	0.02	0.2494	0.2489	0.2502	0.2497	0.516	13.11	870	3900	1430	6400	1910	8500
-	-	0.103	0.05	0.3119	0.3114	0.3127	0.3122	0.672	17.07	2100	9300	2700	12000	3600	16000
-	-	0.187	0.08	0.3744	0.3739	0.3752	0.3747	0.844	21.44	3840	17100	4300	19100	5780	25700
-	-	0.279	0.13	0.4369	0.4364	0.4277	0.4272	0.953	24.21	6150	27400	6400	28500	8530	37900
-	-	0.520	0.24	0.4994	0.4989	0.5002	0.4997	1.109	28.17	8950	39800	10700	47600	14200	63200
-	-	0.749	0.34	0.6244	0.6239	0.6252	0.6247	1.219	30.96	12200	54300	14400	64100	19300	85900
-	-	0.931	0.42	0.7494	0.7489	0.7502	0.7497	1.500	38.10	16300	72500	16400	73000	21800	97000
-	-	1.160	0.53	0.8744	0.8739	0.8752	0.8747	1.625	41.28	25800	114800	18900	84100	25300	112500
-	-	2.360	1.07	0.9994	0.9989	1.0002	0.9997	2.000	50.80	25800	114800	28400	126300	37900	168600
-	-	2.710	1.23	1.2494	1.2488	1.2503	1.2497	2.281	57.94	25800	114800	33500	149000	44600	198400
-	-	3.367	1.53	1.2494	1.2488	1.2503	1.2497	2.562	65.07	25800	114800	36700	163200	48900	217500
-	-	0.107	0.05	0.2494	0.2489	0.2502	0.2497	0.576	14.63	870	3900	2310	10300	3080	13700
0.815	20.70	0.239	0.11	0.3119	0.3114	0.3127	0.3122	0.672	17.07	2100	9300	5370	23900	7130	31700
1.065	27.05	0.437	0.20	0.3744	0.3739	0.3752	0.3747	0.891	22.63	3840	17100	9370	41700	12500	55600
1.315	33.40	0.728	0.33	0.4369	0.4364	0.4377	0.4372	1.109	28.17	6150	27400	15000	66700	19900	88500
1.565	39.75	1.130	0.51	0.4994	0.4989	0.5002	0.4997	1.281	32.54	8950	39800	21400	95200	28500	126800
1.895	48.13	1.630	0.74	0.6244	0.6239	0.6252	0.6247	1.469	37.31	12200	54300	28900	128600	38500	171300
2.045	51.94	2.310	1.05	0.7494	0.7489	0.7502	0.7497	1.578	40.08	16300	72500	33600	149500	44900	199700
2.225	56.52	3.260	1.48	0.8744	0.8739	0.8752	0.8747	1.844	46.84	25800	114800	44600	198400	59500	264700
2.475	62.87	4.330	1.96	0.9994	0.9989	1.0002	0.9997	1.984	50.39	25800	114800	53600	238400	71300	317200
2.685	68.20	6.090	2.76	1.2494	1.2488	1.2503	1.2497	2.281	57.94	25800	114800	69000	306900	92000	409200
2.685	68.20	7.350	3.33	1.2494	1.2488	1.2503	1.2497	2.562	65.07	25800	114800	76000	338100	102000	453700

AIRFRAME CONTROL NEEDLE ROLLER BEARINGS

AeroCres® Reduced Maintenance Track Rollers

RBC's AeroCres® bearings minimize maintenance to reduce downtime

RBC's new AeroCres® bearings provide a system solution that significantly reduces aircraft maintenance and downtime. The innovative design combines an advanced corrosion-resistant steel with a special lubricant and improved seal to set the standard in wing flap/slat performance.

RBC's AeroCres® bearings are made from bearing quality stainless steels that are manufactured using a proprietary process. This material is eight times more corrosion resistant than CRES 440C. These bearings also feature an improved one-piece seal and a special grease to enhance corrosion protection and extend service life.

This dependable wing system solution helps airlines reduce their total maintenance and downtime costs, including flight delays and cancellations.



Outstanding corrosion resistance is the key to the reduced maintenance and extended service life of RBC's new AeroCres® grease bearings.

System Solution Benefits

Maximum Corrosion Resistance –

Unique bearing package with-stands corrosion in flight-tested environments through the combination of special steel, seal and lubricant.

Advanced Steel – Proprietary technology produces a superior material that is 38 times more corrosion resistant than 52100 steel and 8 times greater than CRES 440C.

Effective Seal – Improved one-piece copolymer design provides better protection and lubricant retention, even at regreasing pressures up to 5,800 psi (400 bar).

Superior Grease – AeroCres® grease is formulated to resist wash-out, emulsify water and guard against internal bearing corrosion and rolling contact fatigue.

Extended Service Life – Bearings are designed to resist corrosion and will last up to and beyond the first major maintenance check with minimal relubrication.

Reduced Downtime – Reliable design extends the regular maintenance cycle and minimizes unscheduled bearing replacement.

Bolt-On Replacement – Design permits direct interchange with existing bearings.

Cost Efficiency – Less bearing-related downtime saves maintenance time and money. Reduced flight delays and cancellations help airlines improve revenues.

OEM Approval – Bearings are currently approved for use on various Boeing and Airbus aircraft models.

FAA Approval – FAA/PMA approval allows immediate replacement of current bearings on various aircraft, including most Boeing aircraft.

Wingset Kits – Complete bearing sets for flaps and slats simplify ordering, inventory, handling, and installation.

AeroCres® Reduced Maintenance Track Rollers

Bearing Steel

A proprietary heat treatment of a 400 grade stainless steel produces the advanced material used in RBC AeroCres® bearings. This unique steel provides outstanding corrosion resistance and performance characteristics that are superior to traditional bearing alloy steels under typical operating conditions.

Electrochemical and environmental testing demonstrate unmatched corrosion resistance – 38 times greater than conventional 52100 bearing steel and 8 times over CRES 440C. Also, improved fatigue resistance enables bearings to withstand greater loads for longer cycles.

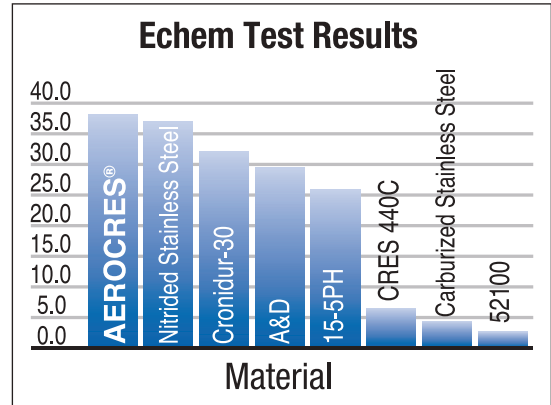

Relative corrosion resistance after electrochemical test.

One-Piece Seal

Bearing design features a one-piece seal and thrust washer molded of BASF N-2310P acetal copolymer with lubricant fillers. This material provides superior wear resistance for both seal lips and thrust washers. The seal mounts securely in the bearing and incorporates pressure-relief features that permit full lubricant retention and function after regreasing with pressures in excess of 5,800 psi (400 bar).

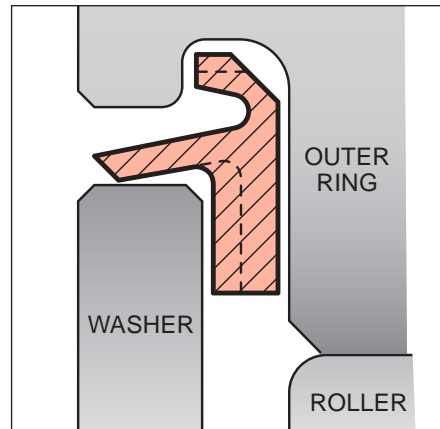

Combination seal and thrust washer resists contamination and retains lubricant.

Special Grease

The special grease is formulated to optimize long-term performance and extend relubrication intervals to achieve 5+ years. This grease is a blend of MIL-PRF 23827 and Braycote® 600EF. It is currently approved to both Airbus and Boeing specifications.

Key Benefits of AeroCres® Grease

- Emulsification of water
- Resistance to washout
- Compatibility with other aircraft industry greases

AIRFRAME CONTROL
NEEDLE ROLLER
BEARINGS

Braycote® is a registered trademark of BP Lubricants USA Inc.

© 2008, 2011, 2018 RBC Bearings Incorporated. All rights reserved.

CONSTRUCTION

This is a non-separable unit, comprising an inner ring, needle rollers, retaining washers, seal/thrust washers, and an extra-thick outer ring to withstand heavy rolling loads. The end washers are fastened to the inner ring. Type ATF has a single row of rollers and type ATL has two rows of rollers. The outer ring of type ATF bearing is crowned.

Inner and outer Rings, needles, and end washers are made from RBC's AeroCres® material and passivated for additional corrosion protection. See our AeroCres® "Featured Page" for more material information.

The seals on the ATF and ATL bearings are located in counterbores of the outer ring and seal against the O.D. of the end washers, providing a good retention of lubricant and exclusion of foreign material. Seal/thrust washers, made of a self-lubricating resin material, separate the steel thrust surfaces, extending the life of lubricant and bearing.

Grooves and holes for relubrication are provided in the inner ring only, since the outer ring must serve as a roller. Type ATF has a groove in the bore of the outer ring for storage of additional lubricant.

DIMENSIONS

Types ATF and ATL are manufactured to inch nominal dimensions. Metric dimensions shown are for the convenience of the user, and the controlling dimensions are in inches. Dimensions listed are for the finished bearing after plating. The shaft diameter dimensions necessary to mount these bearings properly are listed on the facing page.

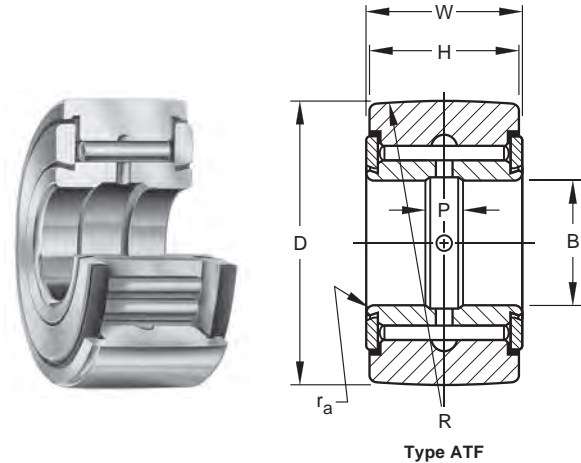

SPECIFICATIONS AND ORDERING INFORMATION

BEARING DIMENSIONS

Bearing Designation	AS5927 AS5928 Dash No.	B* Bore		D* O.D.		W Widths		H		r _a § Shaft Fillet (max.)	P Inner Ring Groove Width (ref.)		R Crown Radius (ref.)		
		+0.00	+0.00	+0.001	+0.025	+0.00	+0.00	+0.00	+0.00		in.	mm	in.	mm	
		-0.007	-0.018	-0.001	-0.025	-0.010	-0.25	-0.010	-0.25						
		in.	mm	in.	mm	in.	mm	in.	mm	in.	mm	in.	mm		
ATF-3-T8	AS5927-103	0.1900	4.826	0.7500	19.05	0.312	7.92	0.280	7.11	0.022	0.56	0.094	2.39	11	279
ATF-4-T8	AS5927-104	0.2500	6.350	0.8750	22.23	0.375	9.53	0.345	8.76	0.022	0.56	0.125	3.18	11	279
ATF-6-T8	AS5927-106	0.3750	9.525	1.0625	26.99	0.500	12.70	0.455	11.56	0.022	0.56	0.188	4.78	11	279
ATF-8-T8	AS5927-108	0.5000	12.700	1.3125	33.34	0.625	15.88	0.580	14.73	0.032	0.81	0.188	4.78	13	330
ATF-10-T8	AS5927-110	0.6250	15.875	1.5000	38.10	0.750	19.05	0.705	17.91	0.032	0.81	0.250	6.35	18	457
ATF-12-T8	AS5927-112	0.7500	19.050	1.7500	44.45	1.000	25.40	0.950	24.13	0.032	0.81	0.250	6.35	31	787
ATF-14-T8	AS5927-114	0.8750	22.225	2.0000	50.80	1.125	28.58	1.075	27.31	0.032	0.81	0.250	6.35	36	914
ATF-16-T8	AS5927-116	1.0000	25.400	2.2500	57.15	1.125	28.58	1.075	27.31	0.032	0.81	0.250	6.35	27	686
ATF-20-T8	AS5927-120	1.2500	31.750	2.5000	63.50	1.250	31.75	1.200	30.48	0.032	0.81	0.375	9.53	61	1549
ATF-24-T8	AS5927-124	1.5000	38.100	3.0000	76.20	1.500	38.10	1.440	36.58	0.032	0.81	0.375	9.53	61	1549
ATF-28-T8	AS5927-128	1.7500	44.450	3.4375	87.31	1.500	38.10	1.440	36.58	0.032	0.81	0.375	9.53	61	1549
ATF-32-T8	AS5927-132	2.0000	50.800	3.8750	98.43	1.500	38.10	1.440	36.58	0.032	0.81	0.375	9.53	61	1549
ATL-4-T8	AS5928-104	0.2500	6.350	0.8750	22.23	0.750	19.05	0.710	18.03	0.022	0.56	0.188	4.78	-	-
ATL-6-T8	AS5928-106	0.3750	9.525	1.1250	28.58	1.000	25.40	0.940	23.88	0.022	0.56	0.188	4.78	-	-
ATL-8-T8	AS5928-108	0.5000	12.700	1.3750	34.93	1.250	31.75	1.190	30.23	0.032	0.81	0.250	6.35	-	-
ATL-10-T8	AS5928-110	0.6250	15.875	1.6250	41.28	1.500	38.10	1.440	36.58	0.032	0.81	0.375	9.53	-	-
ATL-12-T8	AS5928-112	0.7500	19.050	1.8750	47.63	1.750	44.45	1.690	42.93	0.032	0.81	0.375	9.53	-	-
ATL-14-T8	AS5928-114	0.8750	22.225	2.1250	53.98	2.000	50.80	1.940	49.28	0.032	0.81	0.375	9.53	-	-
ATL-16-T8	AS5928-116	1.0000	25.400	2.3750	60.33	2.250	57.15	2.190	55.63	0.032	0.81	0.375	9.53	-	-
ATL-20-T8	AS5928-120	1.2500	31.750	2.7500	69.85	2.500	63.50	2.440	61.98	0.032	0.81	0.375	9.53	-	-
ATL-24-T8	AS5928-124	1.5000	38.100	3.0000	76.20	2.750	69.85	2.690	68.33	0.032	0.81	0.375	9.53	-	-
ATL-28-T8	AS5928-128	1.7500	44.450	3.4375	87.31	3.000	76.20	2.940	74.68	0.032	0.81	0.375	9.53	-	-
ATL-32-T8	AS5928-132	2.0000	50.800	3.8750	98.43	3.000	76.20	2.940	74.68	0.032	0.81	0.375	9.53	3	-

* Bore and O.D. tolerance limits correspond to the single mean diameter (the arithmetical mean of the largest and smallest diameters in a single radial plane).

§ Equal to minimum bearing chamfers.

∅Tolerance for width C for ATL series is +0.000 -0.005 in.

AIRFRAME CONTROL NEEDLE ROLLER BEARINGS

MOUNTING

Types ATF and ATL bearings are designed for heavy rolling loads. The type ATF bearing is usually clevis mounted or cantilever mounted on a high strength shaft or bolt. The type ATL bearing must be straddle-mounted on a high strength shaft or bolt.

The end washers are fastened to the inner ring in a manner only to maintain the integrity of the assembly while handling and installing the bearing. Therefore, when mounted they should be firmly backed up by washers or other clamping surfaces that are flat and square with the shaft center line. To provide sufficient washer support, the outside diameter of the clamping surfaces should be at least as large as the minimum clamping diameter (d_a) listed below.

LOAD RATINGS

Bearings are constructed to provide maximum capacity under rolling loads.

The limit load ratings (also called “allowable working load ratings”) of the bearings are listed below. The ultimate load ratings are not less than 1.5 times the limit load ratings. The ultimate load ratings correspond to 2/3 of the Aircraft Static Capacity ratings.

Load ratings are given in pounds-force:
 1 lbf = 0.454 kgf = 4.448 N

Before final bearing selection is made, please consult an RBC Aerospace Bearings sales engineer.

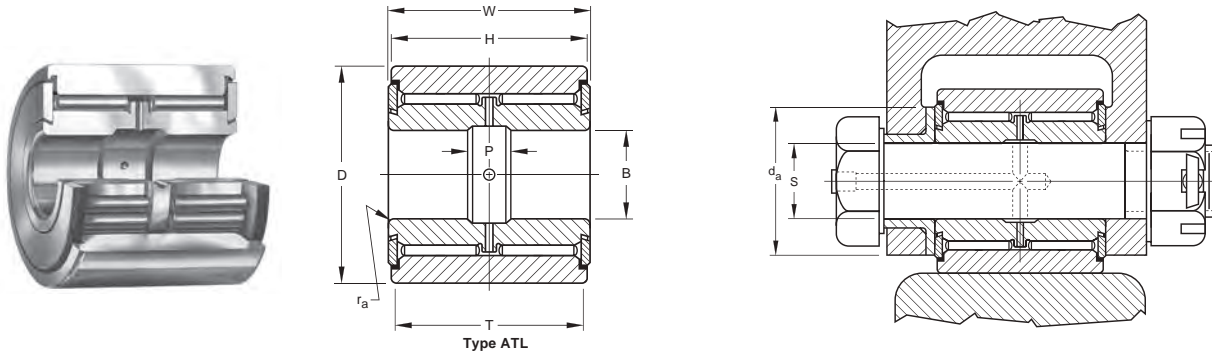

SPECIFICATIONS AND ORDERING INFORMATION

MOUNTING DIMENSIONS

T Track Contact Width (minimum)	Weight (approx.)		S Shaft Diameters				d_a Clamping Diameter (minimum)	Clamping Force (max.)	Bearing Capacity						
			Transition Fits (loose fits)		Transition Fits (tight range)				as a Track Roller (CTR)		Limit Load Rating				
in. mm	lbs	kgs	in.	in.	in.	in.	in.	mm	lbf	N	lbf	N	lbf	N	
-	-	0.030	0.01	0.1894	0.1889	0.1902	0.1897	0.438	11.13	480	2100	900	4000	1200	5300
-	-	0.051	0.02	0.2494	0.2489	0.2502	0.2497	0.516	13.11	870	3900	1430	6400	1910	8500
-	-	0.103	0.05	0.3119	0.3114	0.3127	0.3122	0.672	17.07	2100	9300	2700	12000	3600	16000
-	-	0.187	0.08	0.3744	0.3739	0.3752	0.3747	0.844	21.44	3840	17100	4300	19100	5780	25700
-	-	0.279	0.13	0.4369	0.4364	0.4277	0.4272	0.953	24.21	6150	27400	6400	28500	8530	37900
-	-	0.520	0.24	0.4994	0.4989	0.5002	0.4997	1.109	28.17	8950	39800	10700	47600	14200	63200
-	-	0.749	0.34	0.6244	0.6239	0.6252	0.6247	1.219	30.96	12200	54300	14400	64100	19300	85900
-	-	0.931	0.42	0.7494	0.7489	0.7502	0.7497	1.500	38.10	16300	72500	16400	73000	21800	97000
-	-	1.160	0.53	0.8744	0.8739	0.8752	0.8747	1.625	41.28	25800	114800	18900	84100	25300	112500
-	-	2.360	1.07	0.9994	0.9989	1.0002	0.9997	2.000	50.80	25800	114800	28400	126300	37900	168600
-	-	2.710	1.23	1.2494	1.2488	1.2503	1.2497	2.281	57.94	25800	114800	33500	149000	44600	198400
-	-	3.367	1.53	1.2494	1.2488	1.2503	1.2497	2.562	65.07	25800	114800	36700	163200	48900	217500
-	-	0.107	0.05	0.2494	0.2489	0.2502	0.2497	0.576	14.63	870	3900	2310	10300	3080	13700
0.815	20.70	0.239	0.11	0.3119	0.3114	0.3127	0.3122	0.672	17.07	2100	9300	5370	23900	7130	31700
1.065	27.05	0.437	0.20	0.3744	0.3739	0.3752	0.3747	0.891	22.63	3840	17100	9370	41700	12500	55600
1.315	33.40	0.728	0.33	0.4369	0.4364	0.4377	0.4372	1.109	28.17	6150	27400	15000	66700	19900	88500
1.565	39.75	1.130	0.51	0.4994	0.4989	0.5002	0.4997	1.281	32.54	8950	39800	21400	95200	28500	126800
1.895	48.13	1.630	0.74	0.6244	0.6239	0.6252	0.6247	1.469	37.31	12200	54300	28900	128600	38500	171300
2.045	51.94	2.310	1.05	0.7494	0.7489	0.7502	0.7497	1.578	40.08	16300	72500	33600	149500	44900	199700
2.225	56.52	3.260	1.48	0.8744	0.8739	0.8752	0.8747	1.844	46.84	25800	114800	44600	198400	59500	264700
2.475	62.87	4.330	1.96	0.9994	0.9989	1.0002	0.9997	1.984	50.39	25800	114800	53600	238400	71300	317200
2.685	68.20	6.090	2.76	1.2494	1.2488	1.2503	1.2497	2.281	57.94	25800	114800	69000	306900	92000	409200
2.685	68.20	7.350	3.33	1.2494	1.2488	1.2503	1.2497	2.562	65.07	25800	114800	76000	338100	102000	453700

AIRFRAME CONTROL NEEDLE ROLLER BEARINGS

CONSTRUCTION

This is a non-separable unit, comprising an inner ring, needle rollers, retaining washers and outer ring made extra-thick to better withstand rolling loads. The end washers are fastened to the inner ring. Type NBF has a single row of rollers, and type NBL has two rows of rollers.

Lubrication grooves and holes are provided for relubrication in the inner ring only, since the outer ring must serve as a roller.

For protection from corrosion under the heavy rolling loads, the O.D. of the bearing is chrome plated. Other exposed surfaces, as mounted, are cadmium plated, or zinc-nickel plated.

DIMENSIONS

Dimensions listed below are for the finished bearing after plating.

Bearings are made to ISO and U.S. Military Specifications, and are constructed to have maximum capacity under rolling loads.

The shaft diameter dimensions necessary to mount these bearings properly are listed on the facing page.

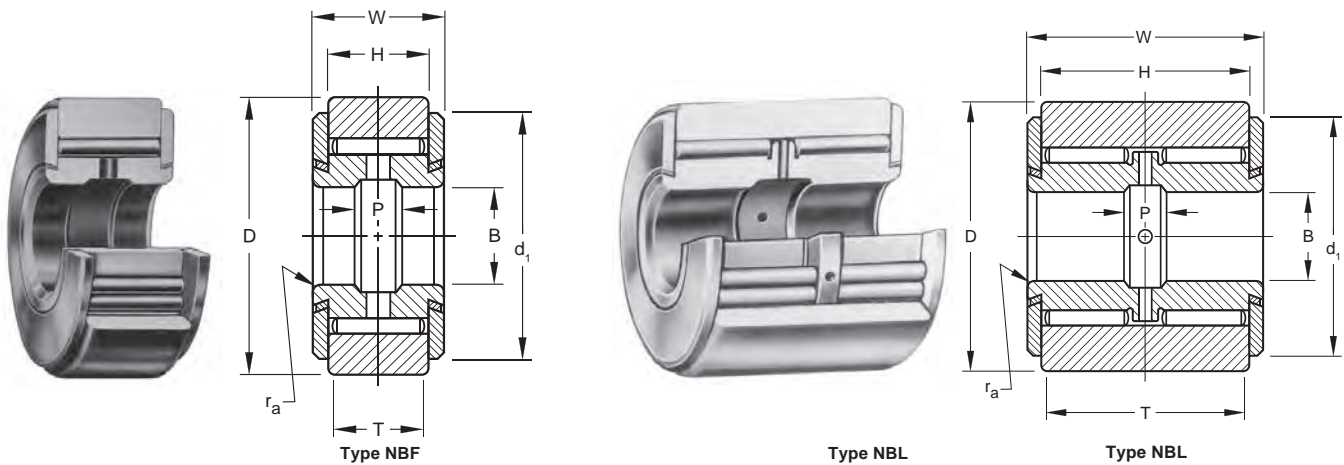

SPECIFICATIONS AND ORDERING INFORMATION

BEARING DIMENSIONS

Bearing Designation	MS24465 MS24466 Dash No.	B* Bore		D* O.D.		W Widths		H		ra § Shaft Fillet (max.)	d1 End Washer Diameter (ref.)		P Inner Ring Groove Width (ref.)		
		+0.00 -0.007	+0.00 -0.018	+0.001 -0.001	+0.025 -0.025	+0.00 -0.005	+0.00 -0.13	∅	+0.00 -0.005		+0.00 -0.13	in.	mm	in.	mm
3NBF512YJ	MS24465-3	0.1900	4.826	0.7500	19.05	0.312	7.92	0.218	5.54	0.022	0.56	0.688	17.48	0.094	2.39
4NBF614YJ	MS24465-4	0.2500	6.350	0.8750	22.23	0.375	9.53	0.281	7.14	0.022	0.56	0.750	19.05	0.125	3.18
6NBF817YJ	MS24465-6	0.3750	9.525	1.0625	26.99	0.500	12.70	0.375	9.53	0.022	0.56	0.938	23.83	0.188	4.78
8NBF1021YJ	MS24465-8	0.5000	12.700	1.3125	33.34	0.625	15.88	0.500	12.70	0.032	0.81	1.188	30.18	0.188	4.78
10NBF1224YJ	MS24465-10	0.6250	15.875	1.5000	38.10	0.750	19.05	0.625	15.88	0.032	0.81	1.375	34.93	0.250	6.35
12NBF1628YJ	MS24465-12	0.7500	19.050	1.7500	44.45	1.000	25.40	0.875	22.23	0.032	0.81	1.625	41.28	0.250	6.35
14NBF1832YJ	MS24465-14	0.8750	22.225	2.0000	50.80	1.125	28.58	1.000	25.40	0.032	0.81	1.875	47.63	0.250	6.35
20NBF2040YJ	MS24465-20	1.2500	31.750	2.5000	63.50	1.250	31.75	1.049	26.64	0.032	0.81	1.906	48.41	0.375	9.53
6NBL1618YJ	MS24466-6	0.3750	9.525	1.1250	28.58	1.000	25.40	0.875	22.23	0.022	0.56	1.000	25.40	0.188	4.78
8NBL2022YJ	MS24466-8	0.5000	12.700	1.3750	34.93	1.250	31.75	1.125	28.58	0.032	0.81	1.250	31.75	0.250	6.35
10NBL2426YJ	MS24466-10	0.6250	15.875	1.6250	41.28	1.500	38.10	1.375	34.93	0.032	0.81	1.500	38.10	0.375	9.53
12NBL2830YJ	MS24466-12	0.7500	19.050	1.8750	47.63	1.750	44.45	1.625	41.28	0.032	0.81	1.750	44.45	0.375	9.53
14NBL3234YJ	MS24466-14	0.8750	22.225	2.1250	53.98	2.000	50.80	1.875	47.63	0.032	0.81	2.000	50.80	0.375	9.53
16NBL3638YJ	MS24466-16	1.0000	25.400	2.3750	60.33	2.250	57.15	2.049	52.04	0.032	0.81	2.125	53.98	0.375	9.53
20NBL4044YJ	MS24466-20	1.2500	31.750	2.7500	69.85	2.500	63.50	2.299	58.39	0.032	0.81	2.500	63.50	0.375	9.53

*Bore and O.D. tolerance limits correspond to the single mean diameter (the arithmetical mean of the largest and smallest diameters in a single radial plane).

§ Equal to minimum inner bearing chamfers.

AIRFRAME CONTROL
NEEDLE ROLLER
BEARINGS

MOUNTING

Types NBF and NBL bearings are designed for heavy rolling loads. The type NBF bearing is usually clevis mounted or cantilever mounted on a high strength shaft or bolt. The type NBL bearing must be straddle-mounted on a high strength shaft or bolt.

The end washers are fastened to the inner ring in a manner only to maintain the integrity of the assembly, while handling and installing the bearing. Therefore, when mounted they should be firmly backed up by washers or other clamping surfaces that are flat and square with the shaft center line. To provide sufficient washer support, the outside diameter of the clamping surfaces should be at least as large as the minimum clamping diameter (d_a) listed below.

LOAD RATINGS

The limit load ratings (also called “allowable working load ratings”) of the bearings are listed below. The ultimate load ratings are not less than 1.5 times the limit load ratings. The ultimate load ratings correspond to 2/3 of the Aircraft Static Capacity ratings.

The track capacity ratings listed below are based on a track hardness equivalent to 40 HRC. For track capacity ratings for other hardness values see the “Engineering for Airframe Needle Roller Bearings” section of this catalog. It is important that the limit load rating of the bearings not be exceeded.

Load ratings are given in pounds-force: 1 lbf = 0.454 kgf = 4.448 N

Before final bearing selection is made, please consult an RBC Aerospace Bearings sales engineer.

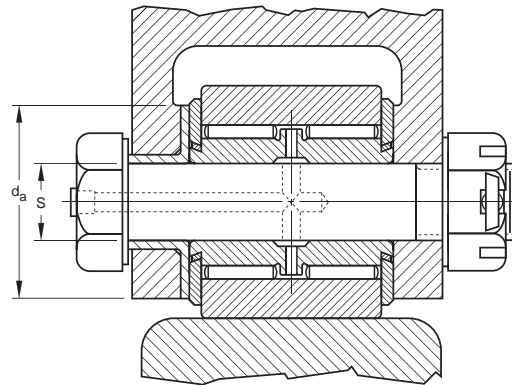

SPECIFICATIONS AND ORDERING INFORMATION

MOUNTING DIMENSIONS

T Track Contact Width (minimum)	Weight (approx.)		S Shaft Diameters				d_a Clamping Diameter (minimum)		Clamping Force (max.)		Bearing Capacity			
			Transition Fits (loose fits)		Transition Fits (tight range)						as a Track Roller (CTR)		Limit Load Rating	
in. mm	lbs	kgs	in.	in.	in.	in.	in.	mm	lbf	N	lbf	N	lbf	N
0.125 3.18	0.029	0.01	0.1894	0.1889	0.1902	0.1897	0.438	11.13	480	2100	900	4000	1200	5300
0.218 5.54	0.049	0.02	0.2494	0.2489	0.2502	0.2497	0.516	13.11	870	3900	1430	6400	1910	8500
0.312 7.92	0.098	0.04	0.3744	0.3739	0.3752	0.3747	0.672	17.07	2100	9300	2700	12000	3600	16000
0.438 11.13	0.178	0.08	0.4994	0.4989	0.5002	0.4997	0.844	21.44	3840	17100	4300	19100	5780	25700
0.562 14.27	0.266	0.12	0.6244	0.6239	0.6252	0.6247	0.953	24.21	6150	27400	6400	28500	8530	37900
0.750 19.05	0.495	0.22	0.7494	0.7489	0.7502	0.7497	1.109	28.17	8950	39800	10700	47600	14200	63200
0.875 22.23	0.713	0.32	0.8744	0.8739	0.8752	0.8747	1.219	30.96	12200	54300	14400	64100	19300	85900
0.938 23.83	1.100	0.50	1.2494	1.2489	1.2503	1.2497	1.625	41.28	25800	114800	18900	84100	25300	112500
0.750 19.05	0.228	0.10	0.3744	0.3739	0.3752	0.3747	0.672	17.07	2100	9300	5370	23900	7130	31700
1.000 25.40	0.416	0.19	0.4994	0.4989	0.5002	0.4997	0.891	22.63	3840	17100	9370	41700	12500	55600
1.125 28.58	0.693	0.31	0.6244	0.6239	0.6252	0.6247	1.109	28.17	6150	27400	15000	66700	19900	88500
1.375 34.93	1.080	0.49	0.7494	0.7489	0.7502	0.7497	1.281	32.54	8950	39800	21400	95200	28500	126800
1.625 41.28	1.550	0.70	0.8744	0.8739	0.8752	0.8747	1.469	37.31	12200	54300	28900	128600	38500	171300
1.797 45.64	2.200	1.00	0.9994	0.9989	1.0002	0.9997	1.578	40.08	16300	72500	33600	149500	44900	199700
2.047 51.99	3.100	1.41	1.2494	1.2488	1.2503	1.2497	1.844	46.84	25800	114800	44600	198400	59500	264700

CONSTRUCTION

This is a non-separable unit, comprising an of inner ring, outer ring, needle rollers, and retaining washers which are fastened to the inner ring.

Grooves and hole for relubrication are provided in the inner ring and outer ring.

External surfaces, except the inner ring bore, are cadmium plated.

DIMENSIONS

Dimensions listed are for the finished bearing after plating.

Bearings are made to ISO and U.S. Military Specifications, and are constructed to have low radial clearance when mounted to minimize vibration and backlash.

The shaft diameter and housing bore dimensions necessary to mount these bearings properly are listed on the facing page.

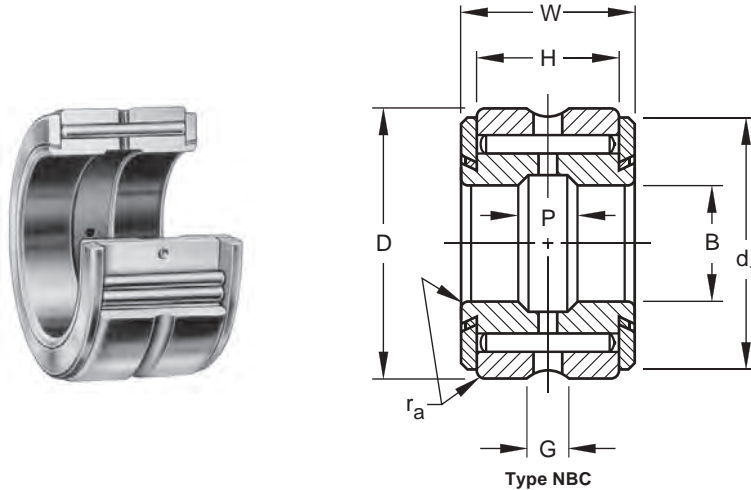

SPECIFICATIONS AND ORDERING INFORMATION

BEARING DIMENSIONS

Bearing Designation	MS24461 Dash No.	B* Bore		D* O.D.		W Widths		H		ra § Shaft Fillet (max.)	d1 End Washer Diameter (ref.)	G Outer Ring Groove Width (ref.)							
		max.	min.	max.	min.	+0.000 -0.005	+0.000 -0.13	+0.000 -0.005	+0.000 -0.13										
		in.	mm	in.	mm	in.	mm	in.	mm	in.	mm	in.	mm						
3NBC511ZP†	MS24461-3	0.1900	4.826	0.1893	4.808	0.6875	17.46	0.6870	17.45	0.312	7.92	0.218	5.54	0.022	0.56	0.625	15.88	0.062	1.57
4NBC612ZP†	MS24461-4	0.2500	6.350	0.2493	6.332	0.7500	19.05	0.7495	19.04	0.375	9.53	0.281	7.14	0.022	0.56	0.688	17.48	0.094	2.39
5NBC713ZP†	MS24461-5	0.3125	7.938	0.3118	7.920	0.8125	20.64	0.8120	20.62	0.437	11.10	0.344	8.74	0.022	0.56	0.750	19.05	0.094	2.39
6NBC914YZP	MS24461-6	0.3750	9.525	0.3743	9.507	0.8750	22.23	0.8745	22.21	0.562	14.27	0.469	11.91	0.022	0.56	0.812	20.62	0.125	3.18
7NBC1015YZP	MS24461-7	0.4375	11.113	0.4368	11.095	0.9375	23.81	0.9370	23.80	0.625	15.88	0.531	13.49	0.032	0.81	0.875	22.23	0.125	3.18
8NBC1218YZP	MS24461-8	0.5000	12.700	0.4993	12.682	1.1250	28.58	1.1245	28.56	0.750	19.05	0.656	16.66	0.032	0.81	1.031	26.19	0.125	3.18
9NBC1419YZP	MS24461-9	0.5625	14.288	0.5618	14.270	1.1875	30.16	1.1870	30.15	0.875	22.23	0.781	19.84	0.032	0.81	1.094	27.79	0.156	3.96
10NBC1620YZP	MS24461-10	0.6250	15.875	0.6243	15.857	1.2500	31.75	1.2495	31.74	1.000	25.40	0.906	23.01	0.032	0.81	1.156	29.36	0.156	3.96
12NBC1822YZP	MS24461-12	0.7500	19.050	0.7493	19.032	1.3750	34.93	1.3745	34.91	1.125	28.58	1.000	25.40	0.032	0.81	1.281	32.54	0.156	3.96
14NBC2026YZP	MS24461-14	0.8750	22.225	0.8743	22.207	1.6250	41.28	1.6245	41.26	1.250	31.75	1.125	28.58	0.032	0.81	1.500	38.10	0.156	3.96
16NBC2028YZP	MS24461-16	1.0000	25.400	0.9993	25.382	1.7500	44.45	1.7495	44.44	1.250	31.75	1.125	28.58	0.032	0.81	1.625	41.28	0.156	3.96
20NBC2032YZP	MS24461-20	1.2500	31.750	1.2493	31.732	2.0000	50.80	1.9994	50.78	1.250	31.75	1.049	26.64	0.032	0.81	1.906	48.41	0.156	3.96
24NBC2036YZP	MS24461-24	1.5000	38.100	1.4993	38.082	2.2500	57.15	2.2494	57.13	1.250	31.75	1.049	26.64	0.032	0.81	2.156	54.76	0.156	3.96
28NBC2040YZP	MS24461-28	1.7500	44.450	1.7493	44.432	2.5000	63.50	2.4994	63.48	1.250	31.75	1.049	26.64	0.032	0.81	2.406	61.11	0.156	3.96
32NBC2044YZP	MS24461-32	2.0000	50.800	1.9993	50.782	2.7500	69.85	2.7494	69.83	1.250	31.75	1.049	26.64	0.032	0.81	2.656	67.46	0.156	3.96
36NBC2048YZP	MS24461-36	2.2500	57.150	2.2493	57.132	3.0000	76.20	2.9994	76.18	1.250	31.75	1.049	26.64	0.032	0.81	2.906	73.81	0.156	3.96
40NBC2052YZP	MS24461-40	2.5000	63.500	2.4993	63.482	3.2500	82.55	3.2492	82.53	1.250	31.75	1.049	26.64	0.032	0.81	3.156	80.16	0.156	3.96
44NBC2056YZP	MS24461-44	2.7500	69.850	2.7493	69.832	3.5000	88.90	3.4992	88.88	1.250	31.75	1.049	26.64	0.032	0.81	3.406	86.51	0.156	3.96
48NBC2060YZP	MS24461-60	3.0000	76.200	2.9993	76.182	3.7500	95.25	3.7492	95.23	1.250	31.75	1.049	26.64	0.032	0.81	3.656	92.86	0.156	3.96
52NBC2064YZP	MS24461-52	3.2500	82.550	3.2382	82.250	4.0000	101.60	3.9992	101.58	1.250	31.75	1.049	26.64	0.032	0.81	3.906	99.21	0.156	3.96
56NBC2070YZP	MS24461-56	3.5000	88.900	3.4992	88.880	4.3750	111.13	4.3742	111.10	1.250	31.75	1.049	26.64	0.044	1.12	4.219	107.16	0.156	3.96
60NBC2074YZP	MS24461-60	3.7500	95.250	3.7492	95.230	4.6250	117.48	4.6242	117.45	1.250	31.75	1.049	26.64	0.044	1.12	4.469	113.51	0.156	3.96
64NBC2078YZP	MS24461-64	4.0000	101.600	3.9992	101.580	4.8750	123.83	4.8740	123.80	1.250	31.75	1.049	26.64	0.044	1.12	4.719	119.86	0.156	3.96

*Bore and O.D. tolerance limits correspond to the single mean diameter (the arithmetical mean of the largest and smallest diameters in a single radial plane).

§ Equal to minimum inner bearing chamfers.

MOUNTING

The housing bore dimensions shown below are applicable to bearings mounted in steel. These dimensions should be decreased .0002 in. (.005mm) when aluminum alloy housings are used.

The end washers are fastened to the inner ring in a manner only to maintain the integrity of the assembly while handling and installing the bearing. Therefore, when mounted, they should be firmly backed up by washers or other clamping surfaces that are flat and square with the shaft center line. To provide sufficient washer support, the outside diameter of the clamping surfaces should be at least as large as the minimum clamping diameter (d_a) listed below.

Tight range transitional fitting practice should not be used for both the outer and the inner rings, since this may cause excessive preloading of the bearing. If this type of mounting becomes necessary, consult an RBC Aerospace Bearings sales engineer for specific recommendations.

LOAD RATINGS

The limit load ratings (also called “allowable working load ratings”) of the bearings are listed below. The ultimate load ratings are not less than 1.5 times the limit load ratings. The ultimate load ratings correspond to the Aircraft Static Capacity ratings.

Load ratings are given in pounds-force:
 1 lbf = 0.454 kgf = 4.448 N

Before final bearing selection is made, please consult an RBC Aerospace Bearings sales engineer.

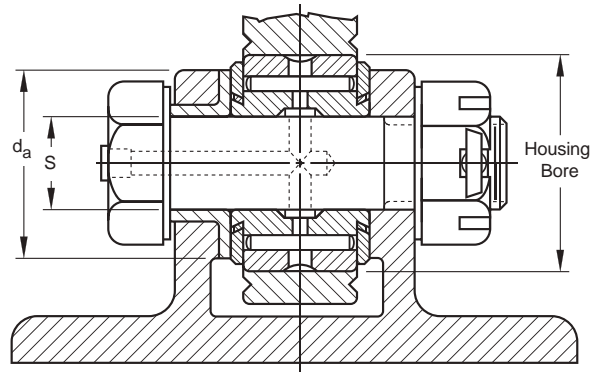

SPECIFICATIONS AND ORDERING INFORMATION

MOUNTING DIMENSIONS

P Inner Ring Groove Width (ref.)	Weight (approx.)	S Shaft Diameters				Housing Bore				d_a Clamping Diameter (minimum)	Clamping Force		Limit Load Rating	
		Transition Fits (loose range)		Transition Fits (tight range)		Transition Fits (tight range)		Transition Fits (loose range)			lbf	N	lbf	N
		max.	min.	max.	min.	max.	min.	max.	min.					
in. mm	lbs kgs	in. in.	in. in.	in. in.	in. in.	in. in.	in. in.	in. in.	in. mm					
- -	0.028 0.01	0.1894 0.1889	0.1902 0.1897	0.6867 0.6872	0.6874 0.6879	0.438 11.13	480 2100	1800 8000						
- -	0.040 0.02	0.2494 0.2489	0.2502 0.2497	0.7492 0.7497	0.7499 0.7504	0.516 13.11	870 3900	2870 12800						
- -	0.057 0.03	0.3119 0.3114	0.3127 0.3122	0.8117 0.8122	0.8124 0.8129	0.578 14.68	1400 6200	4070 18100						
0.188 4.78	0.075 0.03	0.3744 0.3739	0.3752 0.3747	0.8742 0.8747	0.8749 0.8754	0.641 16.28	2100 9300	6330 28200						
0.188 4.78	0.097 0.04	0.4369 0.4364	0.4377 0.4372	0.9367 0.9372	0.9374 0.9379	0.703 17.86	2850 12700	8000 35600						
0.188 4.78	0.165 0.07	0.4994 0.4989	0.5002 0.4997	1.1242 1.1247	1.1249 1.1254	0.844 21.44	3840 17100	11600 51600						
0.188 4.78	0.207 0.09	0.5619 0.5614	0.5627 0.5622	1.1867 1.1872	1.1874 1.1879	0.891 22.63	4870 21700	15000 66700						
0.250 6.35	0.252 0.11	0.6244 0.6239	0.6252 0.6247	1.2492 1.2497	1.2499 1.2504	0.953 24.21	6150 27400	18900 84100						
0.250 6.35	0.336 0.15	0.7494 0.7489	0.7502 0.7497	1.3741 1.3747	1.3749 1.3755	1.078 27.38	8950 39800	23900 106300						
0.375 9.53	0.423 0.19	0.8744 0.8739	0.8752 0.8747	1.6241 1.6247	1.6249 1.6255	1.250 31.75	12200 54300	30500 135700						
0.375 9.53	0.510 0.23	0.9994 0.9989	1.0002 0.9997	1.7491 1.7497	1.7499 1.7505	1.375 34.93	16300 72500	33900 150800						
0.375 9.53	0.600 0.27	1.2494 1.2488	1.2503 1.2497	1.9991 1.9997	1.9999 2.0005	1.625 41.28	25800 114800	37900 168600						
0.375 9.53	0.710 0.32	1.4994 1.4988	1.5003 1.4997	2.2488 2.2496	2.2499 2.2507	1.875 47.63	25800 114800	44200 196600						
0.375 9.53	0.780 0.35	1.7494 1.7488	1.7503 1.7497	2.4988 2.4996	2.4999 2.5007	2.125 53.98	25800 114800	50500 224600						
0.375 9.53	0.880 0.40	1.9994 1.9987	2.0003 1.9996	2.7488 2.7496	2.7499 2.7507	2.375 60.33	25800 114800	56800 252700						
0.375 9.53	0.980 0.44	2.2494 2.2487	2.2503 2.2496	2.9988 2.9996	2.9999 3.0007	2.625 66.68	25800 114800	63100 280700						
0.375 9.53	1.060 0.48	2.4994 2.4987	2.5003 2.4996	3.2485 3.2495	3.2498 3.2508	2.875 73.03	25800 114800	69400 308700						
0.375 9.53	1.150 0.52	2.7494 2.7487	2.7503 2.7496	3.4985 3.4995	3.4998 3.5008	3.125 79.38	25800 114800	75700 336700						
0.375 9.53	1.240 0.56	2.9994 2.9987	3.0003 2.9996	3.7485 3.7495	3.7498 3.7508	3.375 85.73	25800 114800	82000 364800						
0.375 9.53	1.340 0.61	3.2494 3.2486	3.2504 3.2496	3.9985 3.9995	3.9998 4.0008	3.641 92.48	25800 114800	88300 392800						
0.375 9.53	1.730 0.78	3.4994 3.4986	3.5004 3.4996	4.3735 4.3745	4.3748 4.3758	3.969 100.81	25800 114800	96700 430100						
0.375 9.53	1.840 0.83	3.7494 3.7486	3.7504 3.7496	4.6235 4.6245	4.6248 4.6258	4.219 107.16	25800 114800	103000 458200						
0.375 9.53	1.990 0.90	3.9994 3.9986	4.0004 3.9996	4.8735 4.8745	4.8748 4.8758	4.469 113.51	25800 114800	109000 484900						

CONSTRUCTION

This is a non-separable, self-aligning unit comprising an inner ring, needle rollers, outer ring with spherical O.D., retaining washers and housing ring with spherical I.D. The end washers are fastened to the inner ring. Type NBE has a single row of rollers, and type NBK has two rows of rollers.

Lubrication grooves and holes in the inner ring, outer ring and housing ring are provided in the type NBK bearing. The type NBE bearing is similarly designed, except groove and holes in the inner ring are omitted.

The self-aligning bearing outer ring and its housing ring are a matched assembly that must be kept together.

External surfaces, except the inner ring bore, are cadmium or zinc-nickel plated.

DIMENSIONS

Dimensions listed are for the finished bearing after plating.

Bearings are made to ISO and U.S. Military Specifications, and are constructed to have low radial clearance when mounted to minimize vibration and backlash.

The shaft diameter and housing bore dimensions necessary to mount these bearings properly are listed on the facing page.

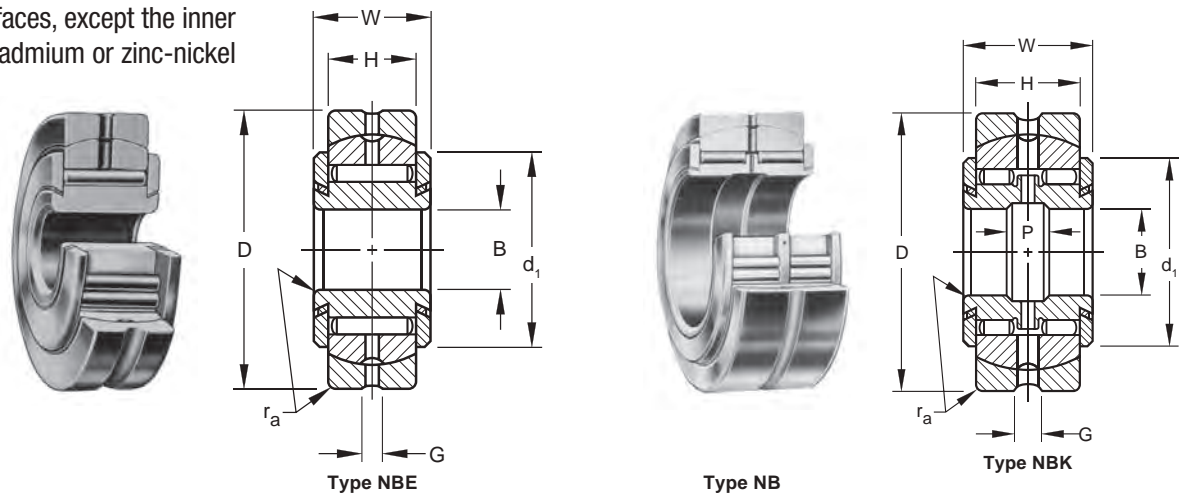

SPECIFICATIONS AND ORDERING INFORMATION

BEARING DIMENSIONS

Bearing Designation	MS24463 MS24464 Dash No.	B* Bore		D* O.D.		W		H		r _s § Shaft Fillet	d ₁ End Washer Diameter (ref.)	G Outer Ring Groove Width (ref.)							
		max.	min.	max.	min.	Widths		Ø											
		in.	mm	in.	mm	in.	mm	in.	mm				in.	mm					
3NBE514ZP	MS24463-3	0.1900	4.826	0.1893	4.808	0.8750	22.23	0.8745	22.21	0.312	7.92	0.218	5.54	0.022	0.56	0.625	15.88	0.062	1.57
4NBE615ZP	MS24463-4	0.2500	6.350	0.2493	6.332	0.9375	23.81	0.9370	23.80	0.375	9.53	0.281	7.14	0.022	0.56	0.688	17.48	0.094	2.39
5NBE717ZP	MS24463-5	0.3125	7.938	0.3118	7.920	1.0625	26.99	1.0620	26.97	0.437	11.10	0.344	8.74	0.022	0.56	0.750	19.05	0.094	2.39
6NBK919YZP	MS24464-6	0.3750	9.525	0.3743	9.507	1.1875	30.16	1.1870	30.15	0.562	14.27	0.469	11.91	0.022	0.56	0.812	20.62	0.125	3.18
7NBK1021YZP	MS24464-7	0.4375	11.113	0.4368	11.095	1.3125	33.34	1.3120	33.33	0.625	15.88	0.531	13.49	0.032	0.81	0.875	22.23	0.125	3.18
8NBK1224YZP	MS24464-8	0.5000	12.700	0.4993	12.682	1.5000	38.10	1.4995	38.09	0.750	19.05	0.656	16.66	0.032	0.81	1.031	26.19	0.125	3.18
9NBK1427YZP	MS24464-9	0.5625	14.288	0.5618	14.270	1.6875	42.86	1.6870	42.85	0.875	22.23	0.781	19.84	0.032	0.81	1.094	27.79	0.156	3.96
10NBK1628YZP	MS24464-10	0.6250	15.875	0.6243	15.857	1.7500	44.45	1.7495	44.44	1.000	25.40	0.906	23.01	0.032	0.81	1.156	29.36	0.156	3.96
12NBK1830YZP	MS24464-12	0.7500	19.050	0.7493	19.032	1.8750	47.63	1.8745	47.61	1.125	28.58	1.000	25.40	0.032	0.81	1.281	32.54	0.156	3.96
14NBK2034YZP	MS24464-14	0.8750	22.225	0.8743	22.207	2.2150	56.26	2.2144	53.96	1.250	31.75	1.125	28.58	0.032	0.81	1.500	38.10	0.156	3.96
16NBK2036YZP	MS24464-16	1.0000	25.400	0.9993	25.382	2.2500	57.15	2.2494	57.13	1.250	31.75	1.125	28.58	0.032	0.81	1.625	41.28	0.156	3.96
20NBK2040YZP	MS24464-20	1.2500	31.750	1.2493	31.732	2.5000	63.50	2.4994	63.48	1.250	31.75	1.049	26.64	0.032	0.81	1.906	48.41	0.156	3.96
24NBK2044YZP	MS24464-24	1.5000	38.100	1.4993	38.082	2.7500	69.85	2.7494	69.83	1.250	31.75	1.049	26.64	0.032	0.81	2.156	54.76	0.156	3.96
32NBK2052YZP	MS24464-32	2.0000	50.800	1.9993	50.782	3.2500	82.55	3.2492	82.53	1.250	31.75	1.049	26.64	0.032	0.81	2.656	67.46	0.156	3.96
40NBK2060YZP	MS24464-40	2.5000	63.500	2.4993	63.482	3.7500	95.25	3.7492	95.23	1.250	31.75	1.049	26.64	0.032	0.81	3.156	80.16	0.156	3.96
48NBK2068YZP	MS24464-48	3.0000	76.200	2.9993	76.182	4.2500	107.95	4.2492	107.93	1.250	31.75	1.049	26.64	0.032	0.81	3.656	92.86	0.156	3.96
56NBK2078YZP	MS24464-56	3.5000	88.900	3.4992	88.880	4.8750	123.83	4.8740	123.80	1.250	31.75	1.049	26.64	0.044	1.12	4.219	107.16	0.156	3.96

*Bore and O.D. tolerance limits correspond to the single mean diameter (the arithmetical mean of the largest and smallest diameters in a single radial plane).

§ Equal to minimum inner bearing chamfers.

MOUNTING

The housing bore dimensions shown below are applicable to bearings mounted in steel. These dimensions should be decreased .0002 in. (.005mm) when aluminum alloy housings are used.

The end washers are fastened to the inner ring in a manner only to maintain the integrity of the assembly while handling and installing the bearing. Therefore, when mounted they should be firmly backed up by washers or other clamping surfaces that are flat and square with the shaft center line. To provide sufficient washer support, the outside diameter of the clamping surfaces should be at least as large as the minimum clamping diameter (d_a) listed below. The maximum clamping diameter is also given to assure that a misalignment of $\pm 5^\circ$ can be accommodated.

LOAD RATINGS

The limit load ratings (also called “allowable working load ratings”) of the bearings are listed below. The ultimate load ratings are not less than 1.5 times the limit load ratings. The ultimate load ratings correspond to the Aircraft Static Capacity ratings.

When the application requires dynamic self-alignment, additional bearing loads (due to the friction of dynamic self-alignment) must be taken into account.

Load ratings are given in pounds-force:
 1 lbf = 0.454 kgf = 4.448 N

Before final bearing selection is made, please consult an RBC Aerospace Bearings sales engineer.

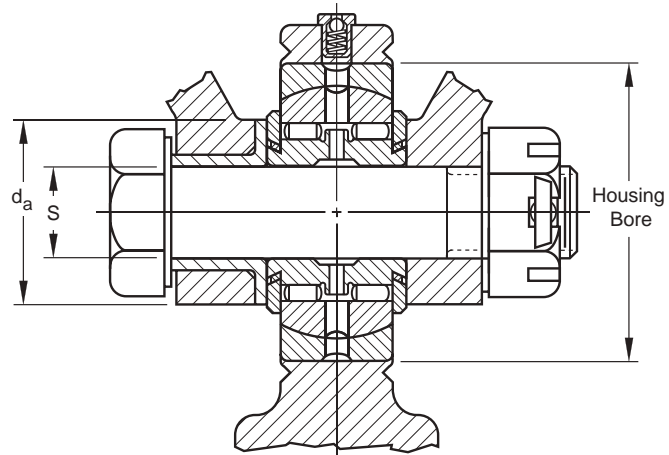

AIRFRAME CONTROL NEEDLE ROLLER BEARINGS

SPECIFICATIONS AND ORDERING INFORMATION

MOUNTING DIMENSIONS

P Inner Ring Groove Width (ref.)	Weight (approx.)		S Shaft Diameters				Housing Bore				d_a Clamping Diameter				Clamping Force (max.)		Limit Load Rating		
			Transition Fits (loose range)		Transition Fits (tight range)		Transition Fits (tight range)		Transition Fits (loose range)		max.		min.						
			max.	min.	max.	min.	max.	min.	max.	min.	in.	mm	in.	mm					
-	-	0.041	0.02	0.1894	0.1889	0.1902	0.1897	0.8742	0.8747	0.8749	0.8754	0.625	15.88	0.438	11.13	480	2100	1800	8000
-	-	0.053	0.02	0.2494	0.2489	0.2502	0.2497	0.9367	0.9372	0.9374	0.9379	0.688	17.48	0.516	13.11	870	3900	2870	12800
-	-	0.079	0.04	0.3119	0.3114	0.3127	0.3122	1.0617	1.0622	1.0624	1.0629	0.734	18.64	0.578	14.68	1400	6200	4070	18100
0.188	4.78	0.130	0.06	0.3744	0.3739	0.3752	0.3747	1.1867	1.1872	1.1874	1.1879	0.781	19.84	0.641	16.28	2100	9300	4530	20200
0.188	4.78	0.174	0.08	0.4369	0.4364	0.4377	0.4372	1.3116	1.3122	1.3124	1.3130	0.844	21.44	0.703	17.86	2850	12700	5870	26100
0.188	4.78	0.293	0.13	0.4994	0.4989	0.5002	0.4997	1.4991	1.4997	1.4999	1.5005	1.000	25.40	0.844	21.44	3840	17100	8670	38600
0.188	4.78	0.420	0.19	0.5619	0.5614	0.5627	0.5622	1.6866	1.6872	1.6874	1.6880	1.062	26.97	0.891	22.63	4870	21700	11800	52500
0.250	6.35	0.520	0.24	0.6244	0.6239	0.6252	0.6247	1.7491	1.7497	1.7499	1.7505	1.094	27.79	0.953	24.21	6150	27400	15500	68900
0.250	6.35	0.630	0.29	0.7494	0.7489	0.7502	0.7497	1.8741	1.8747	1.8749	1.8755	1.156	29.36	1.078	27.38	8950	39800	20000	89000
0.375	9.53	0.870	0.39	0.8744	0.8739	0.8752	0.8747	2.1238	2.1246	2.1249	2.1257	1.375	34.93	1.250	31.75	12200	54300	25800	114800
0.375	9.53	0.960	0.44	0.9994	0.9989	1.0002	0.9997	2.2488	2.2496	2.2499	2.2507	1.500	38.10	1.375	34.93	16300	72500	28700	127700
0.375	9.53	1.070	0.49	1.2494	1.2488	1.2503	1.2497	2.4988	2.4996	2.4999	2.5007	1.781	45.24	1.625	41.28	25800	114800	31400	139700
0.375	9.53	1.230	0.56	1.4994	1.4988	1.5003	1.4997	2.7488	2.7496	2.7499	2.7507	2.062	52.37	1.875	47.63	25800	114800	36600	162800
0.375	9.53	1.490	0.68	1.9994	1.9987	2.0003	1.9996	3.2485	3.2495	3.2498	3.2508	2.594	65.89	2.375	60.33	25800	114800	47100	209500
0.375	9.53	1.780	0.81	2.4994	2.4987	2.5003	2.4996	3.7485	3.7495	3.7498	3.7508	3.062	77.77	2.875	73.03	25800	114800	57500	255800
0.375	9.53	2.060	0.93	2.9994	2.9987	3.0003	2.9996	4.2485	4.2495	4.2498	4.2508	3.562	90.47	3.375	85.73	25800	114800	67900	302000
0.375	9.53	2.650	1.20	3.4994	3.4986	3.5004	3.4996	4.8735	4.8745	4.8748	4.8758	4.141	105.18	3.969	100.81	25800	114800	80100	356300

CONSTRUCTION

This is a non-separable unit comprising a DC-type needle bearing, inner race, and retaining washers. The end washers are fastened to the inner race.

Lubrication grooves and holes are provided in the inner race for all bearings except the 3, 4, and 5 for relubrication purposes. The DC needle bearing can be provided with an oil hole in its outer shell. If so desired, please specify on order.

Exposed surfaces, as mounted, are cadmium plated to meet military specifications.

These bearings must not be used as rollers.

DIMENSIONS

Dimensions given below are for the finished bearing after cadmium plating. Only the nominal bearing O.D. is given since the bearing depends on the housing dimensions for its final sizing.

Bearings are made to AFMBA and military specifications and are constructed to have low radial clearances when mounted, in order to keep vibration and backlash in mechanisms to a minimum.

Shaft diameter and housing bore dimensions necessary to mount these bearings properly are given on the facing page.

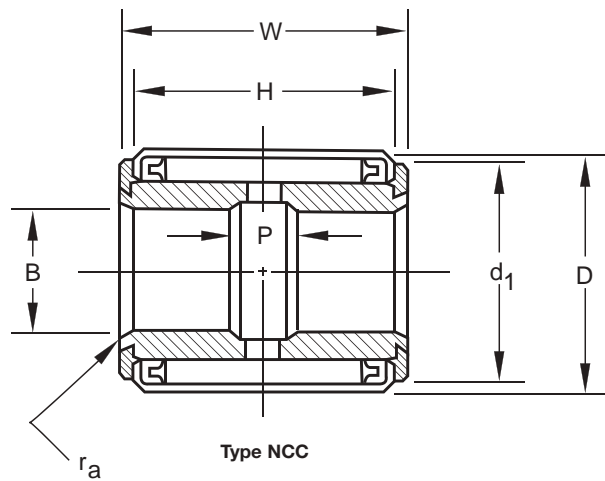

SPECIFICATIONS AND ORDERING INFORMATION

BEARING DIMENSIONS

Bearing Designation	MS24462 Dash No.	B Bore		D Housing Bore		W Widths				H	ra § Radius or 45° Bevel	d1 End Ring Dia.	
		+0.00	+0.00	+0.005	+0.013	+0.00	+0.00	+0.00	+0.00			in.	mm
		-0.005	-0.013	-0.005	-0.013	-0.005	-0.13	-0.10	-0.25				
		in.	mm	in.	mm	in.	mm	in.	mm	in.	mm	in.	mm
3NCC1010P	MS24462-3	0.1900	4.826	0.6250	15.875	0.625	15.88	0.500	12.70	0.022	0.56	0.563	14.30
4NCC910P	MS24462-4	0.2500	6.350	0.6250	15.875	0.562	14.27	0.500	12.70	0.022	0.56	0.563	14.30
5NCC1011P	MS24462-5	0.3125	7.938	0.6875	17.463	0.625	15.88	0.500	12.70	0.022	0.56	0.625	15.88
6NCC1312YP	MS24462-6	0.3750	9.525	0.7500	19.050	0.812	20.62	0.750	19.05	0.022	0.56	0.688	17.48
7NCC1413YP	MS24462-7	0.4375	11.113	0.8125	20.638	0.875	22.23	0.750	19.05	0.032	0.81	0.750	19.05
8NCC1416YP	MS24462-8	0.5000	12.700	1.0000	25.400	0.875	22.23	0.750	19.05	0.032	0.81	0.938	23.83
10NCC1418YP	MS24462-10	0.6250	15.875	1.1250	28.575	0.875	22.23	0.750	19.05	0.032	0.81	1.063	27.00
12NCC1820YP	MS24462-12	0.7500	19.050	1.2500	31.750	1.125	28.58	1.000	25.40	0.032	0.81	1.188	30.18
14NCC1822YP	MS24462-14	0.8750	22.225	1.3750	34.925	1.125	28.58	1.000	25.40	0.032	0.81	1.313	33.35
16NCC1824YP	MS24462-16	1.0000	25.400	1.5000	38.100	1.125	28.58	1.000	25.40	0.032	0.81	1.438	36.53
20NCC2230YP	MS24462-20	1.2500	31.750	1.8750	47.625	1.375	34.93	1.250	31.75	0.032	0.81	1.813	46.05

§ Equal to minimum bearing chamfers.

For aluminum, die castings and similar low tensile housings, consult with an RBC Aerospace Bearings sales engineer.

AIRFRAME CONTROL NEEDLE ROLLER BEARINGS

MOUNTING

The housing bore dimensions shown below are for mounting bearings in steel housings. These dimensions should be decreased .001 in. (.025mm) or more for initial trial if die-cast housings of low tensile strength are used.

End washers are fastened to bearings only to facilitate handling and installation. They should be firmly backed up by washers or other clamping surfaces that are flat and square with the shaft center line. In order to provide sufficient washer support, the outside diameter of the clamping surfaces should be at least as large as the minimum clamping diameters (d_a) given below.

LOAD RATINGS

The Aircraft Static Capacities shown below are obtained by use of the formula:

$$15800 \text{ P.D.} \times l$$

“P.D.” is the bearing pitch diameter and “l” is the effective length of the rollers. They are based on the Aircraft Static Capacities of the DC needle bearings which are components of the NCC bearings.

The allowable dynamic working load should be taken as one-half of the Aircraft Static Capacity.

Load ratings are given in pounds-force:
 1 lbf = 0.454 kgf = 4.448 N

Before final bearing selection is made, please consult an RBC Aerospace Bearings sales engineer.

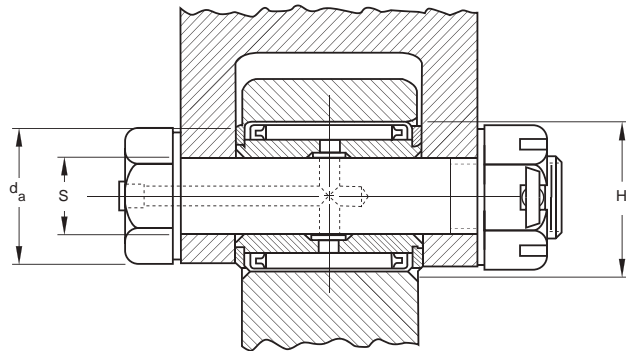

AIRFRAME CONTROL NEEDLE ROLLER BEARINGS

SPECIFICATIONS AND ORDERING INFORMATION

MOUNTING DIMENSIONS

P Inner Race Groove Width	Limit Load Rating	Weight (approx.)	S Shaft Diameters				H Housing Bore Press Fit		d_a Clamping Diameter (minimum)	Clamping Force (max.)
			Transition Fits (loose fits)		Transition Fits (tight range)		max.	min.		
			max.	min.	max.	min.				
in. mm	lbf N	lbs kgs	in. in.	in. in.	in. in.	in. in.	in. mm	lbf N		
0.000 0.00	679 3000	0.040 0.02	0.1894 0.1889	0.1902 0.1897	0.6255 0.6245	0.469 11.91	480 2100			
0.000 0.00	878 3900	0.025 0.01	0.2494 0.2489	0.2502 0.2497	0.6255 0.6245	0.500 12.70	870 3900			
0.000 0.00	988 4400	0.050 0.02	0.3119 0.3114	0.3127 0.3122	0.6880 0.6870	0.563 14.29	1400 6200			
0.188 4.78	1920 8500	0.060 0.03	0.3744 0.3739	0.3752 0.3747	0.7505 0.7495	0.625 15.88	2100 9300			
0.188 4.78	2110 9400	0.090 0.04	0.4369 0.4364	0.4377 0.4372	0.8130 0.8120	0.688 17.46	2850 12700			
0.188 4.78	2350 10500	0.120 0.05	0.4994 0.4989	0.5002 0.4997	1.0005 0.9995	0.844 21.43	3840 17100			
0.250 6.35	2690 12000	0.150 0.07	0.6244 0.6239	0.6252 0.6247	1.1255 1.1245	0.969 24.61	6150 27400			
0.250 6.35	4480 19900	0.210 0.10	0.7494 0.7489	0.7502 0.7497	1.2505 1.2495	1.094 27.78	8950 39800			
0.375 9.53	5000 22200	0.240 0.11	0.8744 0.8739	0.8752 0.8747	1.3755 1.3745	1.219 30.96	12200 54300			
0.375 9.53	5510 24500	0.270 0.12	0.9994 0.9989	1.0002 0.9997	1.5005 1.4995	1.344 34.13	16300 72500			
0.375 9.53	8180 36400	0.300 0.14	1.2494 1.2488	1.2503 1.2497	1.8755 1.8745	1.641 41.67	25800 114800			

CONSTRUCTION

RBC stud type airframe track rollers have been designed for specific use on track type or cam-controlled equipment when cantilever mounting is desired.

Each non-separable unit comprises an outer ring, a full complement of needle rollers, stud, and washer. The O.D. of the outer ring is chromium plated in accordance with the AMS-QQ-C-320, Class 2 specifications to a minimum thickness of .0004 in. All other exposed surfaces are cadmium or zinc-nickel plated. The sealed track rollers have seals made from a special plastic or acetal resin.

Track rollers are available with cylindrical or crowned outer rings. Crowned track rollers reduce the effect of uneven bearing loading resulting from deflection, bending, or misalignment in mounting. A track roller with a cylindrical

outer ring is identified by the prefix letters HRS. A track roller with a crowned outer ring has a letter “C” added to the end of the prefix code (i.e., HRSC).

Normally, the track rollers are prepackaged with a low temperature aircraft grease meeting MIL-PRF-81322 specification, when specified.

DIMENSIONS

Dimensions are for the finished bearing after chrome and cadmium plating. No standard stud length is shown in the tables because the grip length is variable in 1/16 in. increments, coded in the bearing number. Since many combinations of length and type are possible for each track roller size, almost every track roller ordered is a special bearing. See note 3 below for thread specifications.

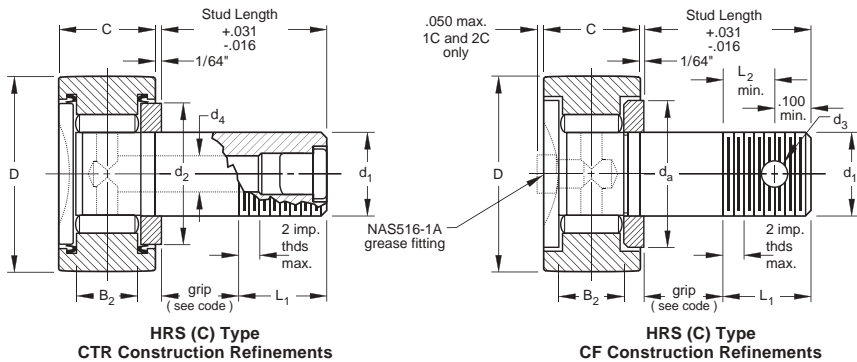
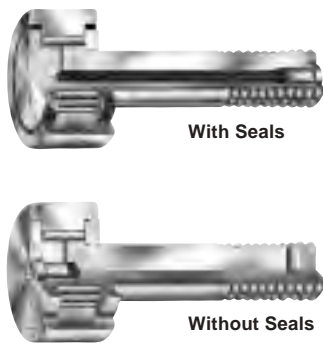

SPECIFICATIONS AND ORDERING INFORMATION

BEARING DIMENSIONS

Bearing Designation	MS21432 Dash No. ⁽⁴⁾	Former NAS 562 Number	d ₁		D O.D. ⁽¹⁾		C O.R. Width		L ₂ min	d ₂ min.	B ₂ Track Contact Width ⁽²⁾ min.	Preferred Max. Grip Length	L ₁ Thread Length (ref.)	Thread Size ⁽³⁾	d ₃ Cotter Pin Hole Diam. (ref.)	d ₄ dia. (ref.)
			Stud Diam.		+0.0010 +.025		+0.000 +.000									
			in.	mm	-0.0015 -.038	-0.0005 -.013	-0.005 -.13	-0.005 -.13								
HRS1C HRSC1C	MS 21432-3	NAS 562-3	0.1900	4.826	0.5000	12.700	0.281	7.14	0.211	0.323	0.230	5/8	0.344	10-32	0.070	none
HRS2C HRSC2C	MS 21432-4	NAS 562-4	0.2500	6.350	0.6875	17.463	0.281	7.14	0.224	0.418	0.230	15/16	0.344	1/4-28	0.076	0.076
HRS3C HRSC3C	MS 21432-5	NAS 562-5	0.3120	7.925	0.7500	19.050	0.344	8.74	0.234	0.494	0.290	1 1/4	0.359	5/16-24	0.076	0.076
HRS4C HRSC4C	MS 21432-6	NAS 562-6	0.3750	9.525	0.8750	22.225	0.469	11.91	0.265	0.575	0.380	1 5/8	0.359	3/8-24	0.106	0.106
HRS5C HRSC5C	MS 21432-7	NAS 562-7	0.4370	11.100	1.0000	25.400	0.531	13.49	0.283	0.680	0.430	1 3/4	0.422	7/16-20	0.106	0.106
HRS6C HRSC6C	MS 21432-8	NAS 562-8	0.5000	12.700	1.1250	28.575	0.656	16.66	0.314	0.744	0.530	1 3/4	0.422	1/2-20	0.106	0.106

(1) Tolerance for crowned outer ring O.D. is +.0010, -.0015.

(2) Applies to cylindrical outer ring design only.

(3) All threads conform to SAE AS-8879 specification, UNJF series and Class 3A. The last two threads on the stud are imperfect threads.

(4) HRSC bearings meet the requirements of SAE AS-21447.

BEARING NUMBER

Bearing numbers for RBC Airframe HRSC and HRS track rollers are based on the ABMA identification system. Each complete bearing number comprises three sections of letter and numeral codes which indicate, in this order, basic type and size, construction refinements, and grip length. The sections of the number are contiguous and not separated by spaces or dashes. Designers should familiarize themselves with the numbering system and use the proper sequence of letters and numerals in print specifications and correspondence.

Section 1 : Basic Bearing Number The letters HRS and HRSC followed by size designations (1C, 2C, etc.) relate to the dimensions given in the tabulation above.

Section 2: Construction Refinements Additional letters, which must appear in the sequence below, indicate special optional features:

- F— lubricator in flanged end of stud.
- T— lubricator in threaded end of stud; cotter pin hole omitted. (Note: the HRS1C stud is too small to permit lubrication through the threaded end.)
- K— stud slotted to receive an MS 27111 washer.
- A— no cotter pin hole.
- R— sealed.

Section 3: Grip Length Number A number indicating the grip length in increments of 1/16 in. Tolerance on grip length is ±.016 in. The nominal stud length is the sum of the nominal grip length and thread length (column L1).

MOUNTING

The bore diameter for the stud is listed in column d_b . Other mounting requirements are track fillet radius (r_a), minimum overhang space (C_a) and minimum clamping diameter (d_a). See footnotes 1 and 2 below for additional requirements.

LOAD RATINGS

To utilize a track roller properly, three different capacities must be considered: the capacity of the material on which the track roller will roll (see Note 3), the capacity of the bearing elements to carry the load (see Note 4), and the capacity of the bearing elements to withstand the maximum radial loads (see Note 5).

Before final bearing selection is made please consult an RBC Aerospace Bearings sales engineer.

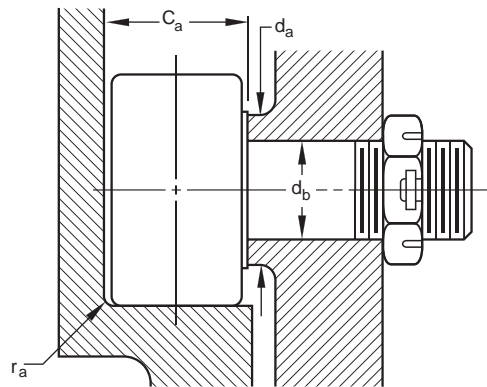
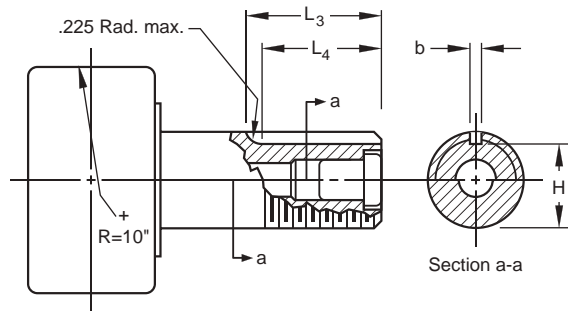

SPECIFICATIONS AND ORDERING INFORMATION

MOUNTING DIMENSIONS

L_4	L_3	b	H	Weight, Pounds Approx. gln=Grip Length Number	d_b Bore Diameter for stud		Mounting Dimensions, Inches					Load Ratings, Pounds		
							r_a Track Fillet Radius (max.)	Rec. Clamping Torque (max.) lb.-in. ⁽¹⁾	C_a + Min. Overhang Space	d_a Clamping Diameter (min.)	Bearing Size No.	Bearing Capacity		
												Track Capacity 40Hrc Steel ⁽³⁾	as a Track Roller ⁽⁴⁾	Limit Load Rating ⁽⁵⁾
+0.030 -0.000	(ref.)	±.0020	±.0030		max.	min.								
n.a.	n.a.	n.a.	n.a.	.014 + (gln x .0005)	0.1905	0.1900	0.010	8	0.313	0.297	1	385	395	790
0.375	0.534	0.0635	0.2143	.031 + (gln x .0009)	0.2505	0.2500	0.010	20	0.313	0.359	2	525	470	940
0.390	0.546	0.0635	0.2768	.043 + (gln x .0014)	0.3120	0.2500	0.010	40	0.376	0.422	3	725	830	1660
0.390	0.572	0.0947	0.3236	.081 + (gln x .0020)	0.3755	0.3750	0.025	55	0.501	0.500	4	1100	1360	2720
0.453	0.635	0.0947	0.3861	.125 + (gln x .0026)	0.4375	0.4370	0.025	150	0.563	0.562	5	1425	1930	3860
0.453	0.662	0.1260	0.4330	.190 + (gln x .0035)	0.5005	0.5000	0.040	205	0.688	0.625	6	1975	3040	6080

(1) The maximum recommended clamping torque is based on lubricated threads. If threads are dry, the torque values listed may be doubled.
 (2) The edge of the housing which supports the stud shank should be as sharp as possible, without burrs, and square with the stud centerline.
 (3) Track capacity is critical with respect to bearing rolling capacity. Increase in track hardness will increase track capacity. Never exceed bearing capacity as a track roller under dynamic conditions.
 (4) The highest load that can be applied to a bearing for a life of 20,000 revolutions, L10.
 (5) The limit load is the maximum radial load which can be applied to a bearing without impairing the subsequent functioning of the bearing in airframe applications. To realize this rating fully, compensation must be provided for stud deflection in order to assure full track contact under load. The static fracture load (Aircraft Static Capacity) is not less than 1.5 times the limit load rating.

BEARING NUMBER EXAMPLES (RBC WITH MS EQUIVALENTS)

RBC-ABMA HRS3CT7 — equivalent to MS 21432-5T7

Track roller with .7500 in. outer ring O.D.; .344 in. outer ring width; .3120 in. stud diameter; lubricator in threaded end of stud; cotter pin hole omitted; and a 7/16 in. grip length.

RBC-ABMA HRSC4CFR6 — equivalent to MS 21477-6F6

Track roller with .8750 in. outer ring O.D.; .469 in. outer ring width; .3750 in. stud diameter; lubricator in threaded end of stud; .106 in. diameter cotter pin hole located in threaded end of stud; sealed; and a 6/16 in. grip length.

RBC-ABMA HRS2CTK3 — no equivalent to MS 21432

Track roller with .6875 in. outer ring O.D.; .281 in. outer ring width; .2500 in. stud diameter; lubricator in threaded end of stud. Stud slotted to receive an MS 27111 key washer; and a 3/16 in. grip length.

*The NAS 516-1A grease fitting is flush or indented on all sizes except HRS1CF and HRS2CF, where it protrudes .050 in. Accordingly, when these two sizes are mounted, dimension C_a must be adjusted to accommodate the slight protrusion.

AIRFRAME CONTROL NEEDLE ROLLER BEARINGS

AeroCres® Fracture-tough Airframe Products

Fracture-tough airframe products enhance corrosion resistance

For many years, corrosion has been a significant problem with bearings used in the aircraft industry. While CRES 440C has been used successfully in many aircraft applications, it is not suitable for the demands of rod end banjos or track roller studs. These two bearing components require a full Rc 58 hardness in the raceway area and a softer, tougher material elsewhere. This is not attainable with CRES 440C. RBC's AeroCres® products provide the unique solution that meets these dual material requirements.

We have selected a specialized carburized stainless steel, and have developed and optimized the heat treatment process that resulted in a homogeneous microstructure — delivering both corrosion protection and core fracture toughness.

Currently, this new material is being used for many structural bearing components such as rod end banjos, track roller studs, and outer rings. Fracture toughness, corrosion resistance, and long fatigue life are critical requirements for these components.



AeroCres® fracture-tough airframe products offer enhanced corrosion resistance in harsh operating environments.

AIRFRAME CONTROL
NEEDLE ROLLER
BEARINGS

Benefits

- Excellent fracture toughness superior to CRES 440C.
- Proven corrosion resistance similar to CRES 440C.
- Compressive residual stresses in carburized case.
- Lower starting torque after extended exposure to a neutral salt solution (ASTM-G44).

- Meets or exceeds government requirements for fatigue and static testing per AS 39901.
- Longer bearing life resisting premature corrosion.

Applications

Bearings located in exposed corrosive positions of aircraft such as:

- Landing gear and doors
- Leading and trailing edges
- Engine controls
- Tail sections

AeroCres® Fracture-tough Airframe Products

Corrosion Resistance Comparison

AeroCres® Rod End vs. 8620/52100 Rod End

	<p>Alternate Immersion Corrosion Test ASTM G44-88 Results* (1,000 hours)</p> <p>Standard Assembly: 8620 rod end outers with 52100 steel inner ring and balls</p> <p>Corrosion Resistant CRES Assembly: AeroCres® rod end outer with CRES 440C inner ring and balls</p>	<table border="1"> <caption>Alternate Immersion Corrosion Test Torque Results</caption> <thead> <tr> <th>Time (hours)</th> <th>8620/52100 Rod Ends (Nm)</th> <th>AeroCres® Rod Ends (Nm)</th> </tr> </thead> <tbody> <tr><td>0</td><td>0.00</td><td>0.00</td></tr> <tr><td>25</td><td>0.02</td><td>0.00</td></tr> <tr><td>50</td><td>0.03</td><td>0.01</td></tr> <tr><td>75</td><td>0.04</td><td>0.01</td></tr> <tr><td>100</td><td>0.05</td><td>0.02</td></tr> <tr><td>150</td><td>0.14</td><td>0.03</td></tr> <tr><td>200</td><td>-</td><td>0.04</td></tr> <tr><td>250</td><td>-</td><td>0.05</td></tr> <tr><td>300</td><td>-</td><td>0.05</td></tr> <tr><td>350</td><td>-</td><td>0.05</td></tr> <tr><td>400</td><td>-</td><td>0.05</td></tr> <tr><td>450</td><td>-</td><td>0.05</td></tr> <tr><td>500</td><td>-</td><td>0.05</td></tr> <tr><td>550</td><td>-</td><td>0.05</td></tr> <tr><td>600</td><td>-</td><td>0.05</td></tr> <tr><td>650</td><td>-</td><td>0.05</td></tr> <tr><td>700</td><td>-</td><td>0.05</td></tr> <tr><td>750</td><td>-</td><td>0.07</td></tr> <tr><td>800</td><td>-</td><td>0.06</td></tr> <tr><td>850</td><td>-</td><td>0.06</td></tr> <tr><td>900</td><td>-</td><td>0.07</td></tr> <tr><td>950</td><td>-</td><td>0.06</td></tr> <tr><td>1000</td><td>-</td><td>0.07</td></tr> </tbody> </table>	Time (hours)	8620/52100 Rod Ends (Nm)	AeroCres® Rod Ends (Nm)	0	0.00	0.00	25	0.02	0.00	50	0.03	0.01	75	0.04	0.01	100	0.05	0.02	150	0.14	0.03	200	-	0.04	250	-	0.05	300	-	0.05	350	-	0.05	400	-	0.05	450	-	0.05	500	-	0.05	550	-	0.05	600	-	0.05	650	-	0.05	700	-	0.05	750	-	0.07	800	-	0.06	850	-	0.06	900	-	0.07	950	-	0.06	1000	-	0.07
Time (hours)	8620/52100 Rod Ends (Nm)	AeroCres® Rod Ends (Nm)																																																																								
0	0.00	0.00																																																																								
25	0.02	0.00																																																																								
50	0.03	0.01																																																																								
75	0.04	0.01																																																																								
100	0.05	0.02																																																																								
150	0.14	0.03																																																																								
200	-	0.04																																																																								
250	-	0.05																																																																								
300	-	0.05																																																																								
350	-	0.05																																																																								
400	-	0.05																																																																								
450	-	0.05																																																																								
500	-	0.05																																																																								
550	-	0.05																																																																								
600	-	0.05																																																																								
650	-	0.05																																																																								
700	-	0.05																																																																								
750	-	0.07																																																																								
800	-	0.06																																																																								
850	-	0.06																																																																								
900	-	0.07																																																																								
950	-	0.06																																																																								
1000	-	0.07																																																																								
<p>Salt Spray Test Results (1,000 hours) ASTM-B117</p>	<p>Alternative Immersion Corrosion Test ASTM-G44-88 Results* (1,000 hours)</p>	<p>Microstructure AeroCres® fracture-tough material vs. CRES 440C</p>																																																																								
<p>Plated 8620 Rod End Outer with 52100 Steel Inner Ring and Balls</p> <p>Plated AeroCres® Rod End Outer with CRES 440C Inner Ring and Balls</p>	<p>CRES 440C</p> <p>AeroCres® fracture-tough material</p>																																																																									

AIRFRAME CONTROL NEEDLE ROLLER BEARINGS

Approvals

- BACB10GS
- BACB10GY
- BACB10GZ

Engineering Support

- Application consultation
- Product design
- Product testing
- Metallurgical analysis
- Heat treating, stainless, and other high-alloy steels

Ordering Information

- Contact RBC Customer Service

CONSTRUCTION

RBC stud type airframe track rollers have been designed for specific use on track type or cam-controlled equipment when cantilever mounting is desired.

Each non-separable unit comprises an outer ring, a full complement of needle rollers, stud, and washer. The outer rings are passivated for addition corrosion protection. All other exposed surfaces are cadmium or zinc-nickel plated. The sealed track rollers have seals made from a special plastic or acetal resin.

All track rollers have a crowned outer ring. Crowned track rollers reduce the effect of uneven bearing loading resulting from deflection, bending, or misalignment in mounting. Bearings identified by the prefix AAHRSC utilize CREN per AMS5925 for the stud material, defined by AS5929-xA

designation. Bearings identified by the prefix AHRSC utilize CRES per AMS5930 for the stud material, defined by AS5929-xB designation. Track rollers are prepackages with a superior grease formulated to resist washout, emulsify water, and guard against internal bearing corrosion and rolling contact fatigue.

DIMENSIONS

Dimensions are for the finished bearing after surface treatment. No standard stud length is shown in the tables because the grip length is variable in 1/16 in. increments, coded in the bearing number. Since many combinations of length and type are possible for each track roller size, almost every track roller ordered is a special bearing. See note 2 below for thread specifications.

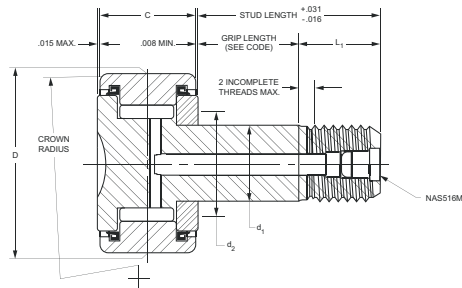
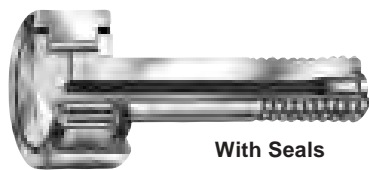

(A) AHRSC Type
Lube Fitting in Threaded End

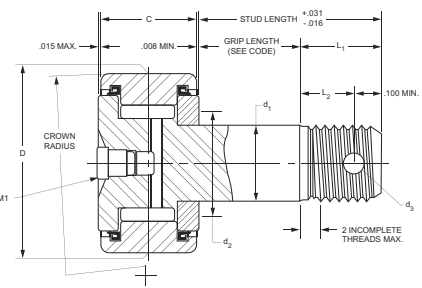

(A) AHRSC Type
Lube Fitting in Flange End, Cotter Pin Hole

SPECIFICATIONS AND ORDERING INFORMATION

BEARING DIMENSIONS

Bearing Designation	AS5929 Dash No.	d ₁ Stud Diam.		D O.D. ⁽¹⁾		C O.R. Width		L ₂ min	d ₂ min. clamping	Crown Radius (ref.)	Preferred Max. Grip Length	L ₁ Thread Length (ref.)	Thread Size ⁽²⁾	d ₃ Cotter Pin Hole Diam. (ref.)	
		+0.000 -.0015	+0.00 -.038	+0.0010 -.0005	+0.025 -.013	+0.000 -.005	+0.000 -.13								in.
AHRSC1	AAHRSC1	AS5929-3	0.1900	4.826	0.5000	12.700	0.281	7.14	0.211	0.297	10	5/8	0.344	10-32	0.070
AHRSC2	AAHRSC2	AS5929-4	0.2500	6.350	0.6875	17.463	0.281	7.14	0.224	0.359	10	15/16	0.344	1/4-28	0.076
AHRSC3	AAHRSC3	AS5929-5	0.3120	7.925	0.7500	19.050	0.344	8.74	0.234	0.422	10	1 1/4	0.359	5/16-24	0.076
AHRSC4	AAHRSC4	AS5929-6	0.3750	9.525	0.8750	22.225	0.469	11.91	0.265	0.500	10	1 5/8	0.359	3/8-24	0.106
AHRSC5	AAHRSC5	AS5929-7	0.4370	11.100	1.0000	25.400	0.531	13.49	0.283	0.562	10	1 3/4	0.422	7/16-20	0.106
AHRSC6	AAHRSC6	AS5929-8	0.5000	12.700	1.1250	28.575	0.656	16.66	0.314	0.625	10	1 3/4	0.422	1/2-20	0.106

(1) Tolerance for crowned outer ring O.D. is +.0010, -.0015.

(2) All threads conform to SAE AS-8879 specification, UNJF series and Class 3A. The last two threads on the stud are imperfect threads.

BEARING NUMBER

Bearing numbers for RBC Airframe AHRSC and AAHRSC track rollers are based on the ABMA identification system. Each complete bearing number is comprised of four sections of letter and numeral codes which indicate, in this order, basic type and size, construction refinements, grip length, and optional locking feature. The sections of the number are contiguous and not separated by spaces or dashes. Designers should familiarize themselves with the numbering system and use the proper sequence of letters and numerals in print specifications and correspondence. See page 76 for further information on product nomenclature.

Section 1 : Basic Bearing Number The letters AHRSC and AAHRSC followed by size designations (1, 2, etc.) relate to the dimensions given in the tabulation above. All AS5929 stud type track rollers beginning with either A or AA prefixes are sealed.

Section 2: Construction Refinements Additional letters, which must appear in the sequence below, indicate standard optional features:

- F- lubricator in flanged end of stud.
- T- lubricator in threaded end of stud, cotter pin hole omitted.
- R- no re-lubrication holes or fitting.
- C- exposed surfaces of stud and end washer cadmium plated.
- P- stud and end washer passivated.
- Z- exposed surfaces of stud (except threads) and end washer zinc-nickel plated.

Section 3: Grip Length Number A number indicating the grip length in increments of 1/16 in. Tolerance on grip length is +.016 in. The nominal stud length is the sum of the nominal grip length and thread length (column L1).

Section 4: Optional Locking Feature The letter A designates no cotter pin hole feature in the threads of the stud. If this section is blank, the stud shall have a cotter pin hole unless a threaded end lubricator (T) has been assigned in Section 2.

MOUNTING

The bore diameter for the stud is listed in column d_b . Other mounting requirements are track fillet radius (r_a), minimum overhang space (C_a) and minimum clamping diameter (d_a). See footnotes 1 and 2 below for additional requirements.

LOAD RATINGS

To utilize a track roller properly, three different capacities must be considered: the capacity of the material on which the track roller will roll (see Note 3), the capacity of the bearing elements to carry the load (see Note 4), and the capacity of the bearing elements to withstand the maximum radial loads (see Note 5).

Before final bearing selection is made please consult an RBC Aerospace Bearings sales engineer.

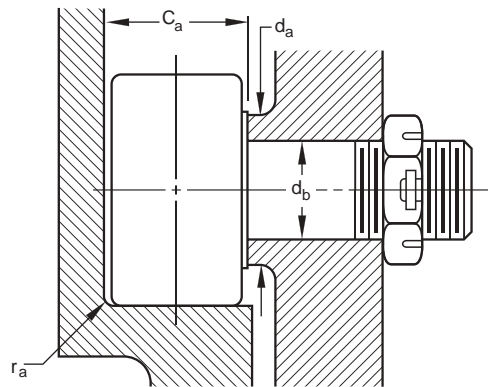
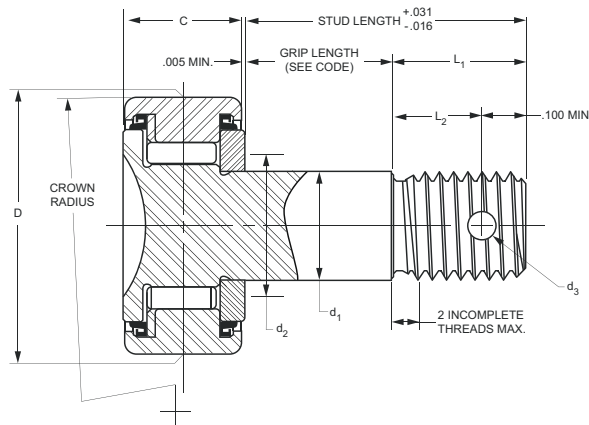

(A) AHRSC Type
No Lube Fitting, Cotter Pin Hole

SPECIFICATIONS AND ORDERING INFORMATION

MOUNTING DIMENSIONS

Weight, Pounds Approx. gln=Grip Length Number	d_b Bore Diameter for stud ⁽²⁾		Mounting Dimensions, Inches					Bearing Capacity		
	max.	min.	r_a Track Fillet Radius (max.)	Rec. Clamping Torque (max.) lb.-in. ⁽¹⁾	C_a * Min. Overhang Space	d_a Clamping Diameter (min.)	Bearing Size No.	Track Capacity 40Hrc Steel ⁽³⁾	as a Track Roller ⁽⁴⁾	Limit Load Rating ⁽⁵⁾
.014 + (gln x .0005)	0.1905	0.1900	0.010	8	0.313	0.297	1	385	395	790
.031 + (gln x .0009)	0.2505	0.2500	0.010	20	0.313	0.359	2	525	470	940
.043 + (gln x .0014)	0.3120	0.2500	0.010	40	0.376	0.422	3	725	830	1660
.081 + (gln x .0020)	0.3755	0.3750	0.025	55	0.501	0.500	4	1100	1360	2720
.125 + (gln x .0026)	0.4375	0.4370	0.025	150	0.563	0.562	5	1425	1930	3860
.190 + (gln x .0035)	0.5005	0.5000	0.040	205	0.688	0.625	6	1975	3040	6030

⁽¹⁾ The maximum recommended clamping torque is based on lubricated threads. If threads are dry, the torque values listed may be doubled.

⁽²⁾ The edge of the housing which supports the stud shank should be as sharp as possible, without burrs, and square with the stud centerline.

⁽³⁾ Track capacity is critical with respect to bearing rolling capacity. Increase in track hardness will increase track capacity. Never exceed bearing capacity as a track roller under dynamic conditions.

⁽⁴⁾ The highest load that can be applied to a bearing for a life of 40,000 revolutions, L10.

⁽⁵⁾ The limit load is the maximum radial load which can be applied to a bearing without impairing the subsequent functioning of the bearing in airframe applications. To realize this rating fully, compensation must be provided for stud deflection in order to assure full track contact under load. The static fracture load (Aircraft Static Capacity) is not less than 1.5 times the limit load rating.

BEARING NUMBER EXAMPLES (RBC WITH AS EQUIVALENTS)

RBC-ABMA AHRSC3TZ7 — equivalent to AS 5929-5BTE7

Track roller with .7500 in. outer ring O.D.; .344 in. outer ring width; .3120 in. stud diameter; lubricator in threaded end of stud; cotter pin hole omitted; 7/16 in. grip length; sealed; stud material CRES per AMS5390; and exposed surfaces of stud (except threads) and end washer zinc-nickel plated.

RBC-ABMA AAHRSC4FC6 — equivalent to AS 5929-6AFC6

Track roller with .8750 in. outer ring O.D.; .469 in. outer ring width; .3750 in. stud diameter; lubricator in flange end of stud; .106 in. diameter cotter pin hole located in threaded end of stud; 6/16 in. grip length; sealed; stud material CREN per AMS5925; and exposed surfaces of stud and end washer cadmium plated.

RBC-ABMA AAHRSC2FP3A — equivalent to AS 5929-4AFP3A

Track roller with .6875 in. outer ring O.D.; .281 in. outer ring width; .2500 in. stud diameter; lubricator in flange end of stud; cotter pin hole omitted; 3/16 in. grip length; sealed; stud material CREN per AMS5925; and stud and end washer passivated.

*The NAS516M1 grease fitting is flush or indented on all sizes except (A)AHRSC1 and (A)AHRSC2, where it protrudes .050 in. Accordingly, when these two sizes are mounted, dimension C_a must be adjusted to accommodate the slight protrusion.

SPECIAL DESIGNS

Standard catalog airframe bearings are not always suitable in aircraft design. When unusual or demanding requirements present bearing application problems, special bearing solutions are required.

Prototype bearings can be made to meet the critical time schedules of development projects.

Stud type track rollers can be manufactured with the customary concentric studs, or eccentric studs that will permit adjustment at the time of assembly. Both types are illustrated on this page along with typical installation arrangements.

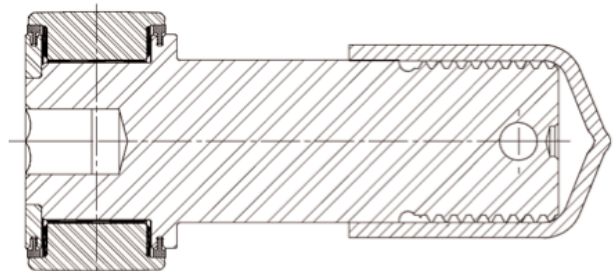
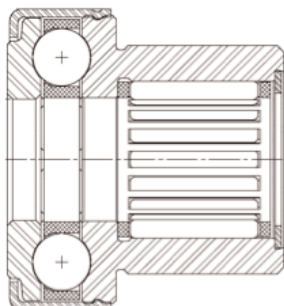
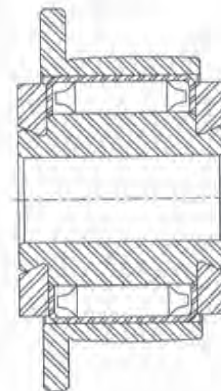
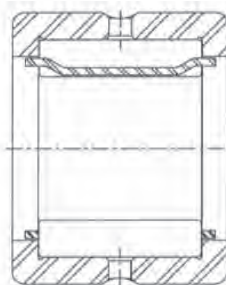
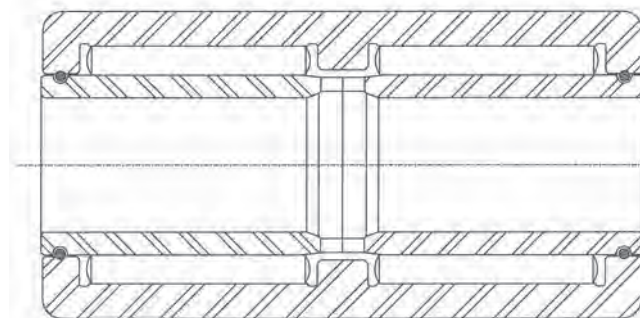
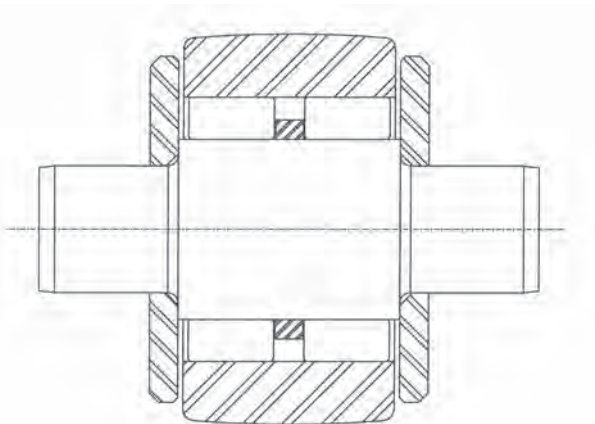
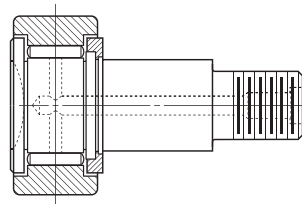
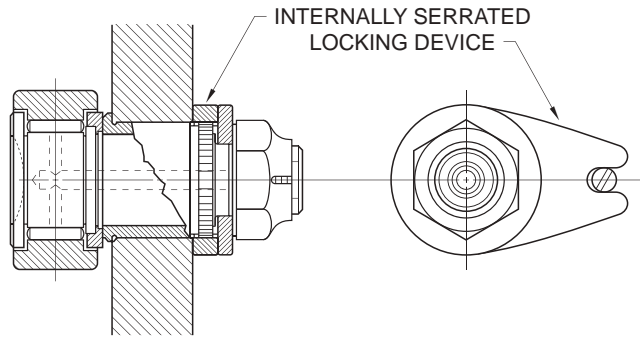

AIRFRAME CONTROL
NEEDLE ROLLER
BEARINGS

RBC Airframe Control Lined Roller Bearings

PRODUCT NOMENCLATURE 105

Engineering Section for Lined Track Rollers and Stud-type Track Rollers 106

AIRFRAME CONTROL

LINED TRACK ROLLERS AND STUD-TYPE TRACK ROLLERS

Single/Double Row Sealed Series

ATF-LNA Narrow Series, Sealed 107

ATL-LNA Wide Series, Sealed 107

ALHR Series: Stud Type Track Rollers 108

GENERAL FEATURES AND TECHNICAL SPECIFICATIONS

Washers & Seals

The washers are press-fit, staked, or laser welded to the inner ring and contain part specific identification. One piece copolymer, labyrinth seals deter contaminants from entering the bearing.

Inner Ring

Inner ring raceway is lined to carry load. The inner ring bore does not contain lubrication grooves or holes since the bearing is “self-lubricating”.

Construction

A non-separable unit consisting of an inner ring, outer ring, washers and seals. Bearing widths and liner areas will vary based on loading conditions and mounting applications.

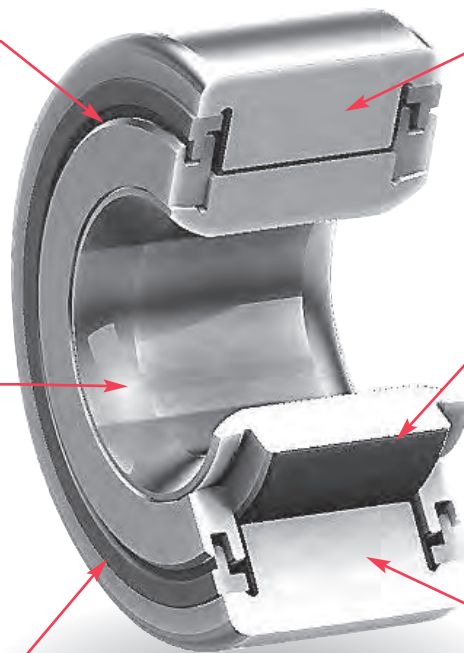

Outer Ring

Outer rings have a crowned OD. Axial loaded surfaces are lined to reduce friction between the outer ring and washers.

Self-Lubricating Liner

Low friction PTFE self-lubricating, homogeneous, non-peelable machinable liner system which offers maintenance-free solution

Materials

Various materials are used for lined track roller construction such as Custom 455, 52100, 17-4PH, PH13-8MO or AeroCres®. AeroCres® is a highly corrosion resistant steel hardened using an RBC proprietary process. See our AeroCres® “Featured Product” pages (85-86) for more material information.

AIRFRAME CONTROL
LINED ROLLER
BEARINGS

AIRFRAME CONTROL LINED ROLLER BEARINGS

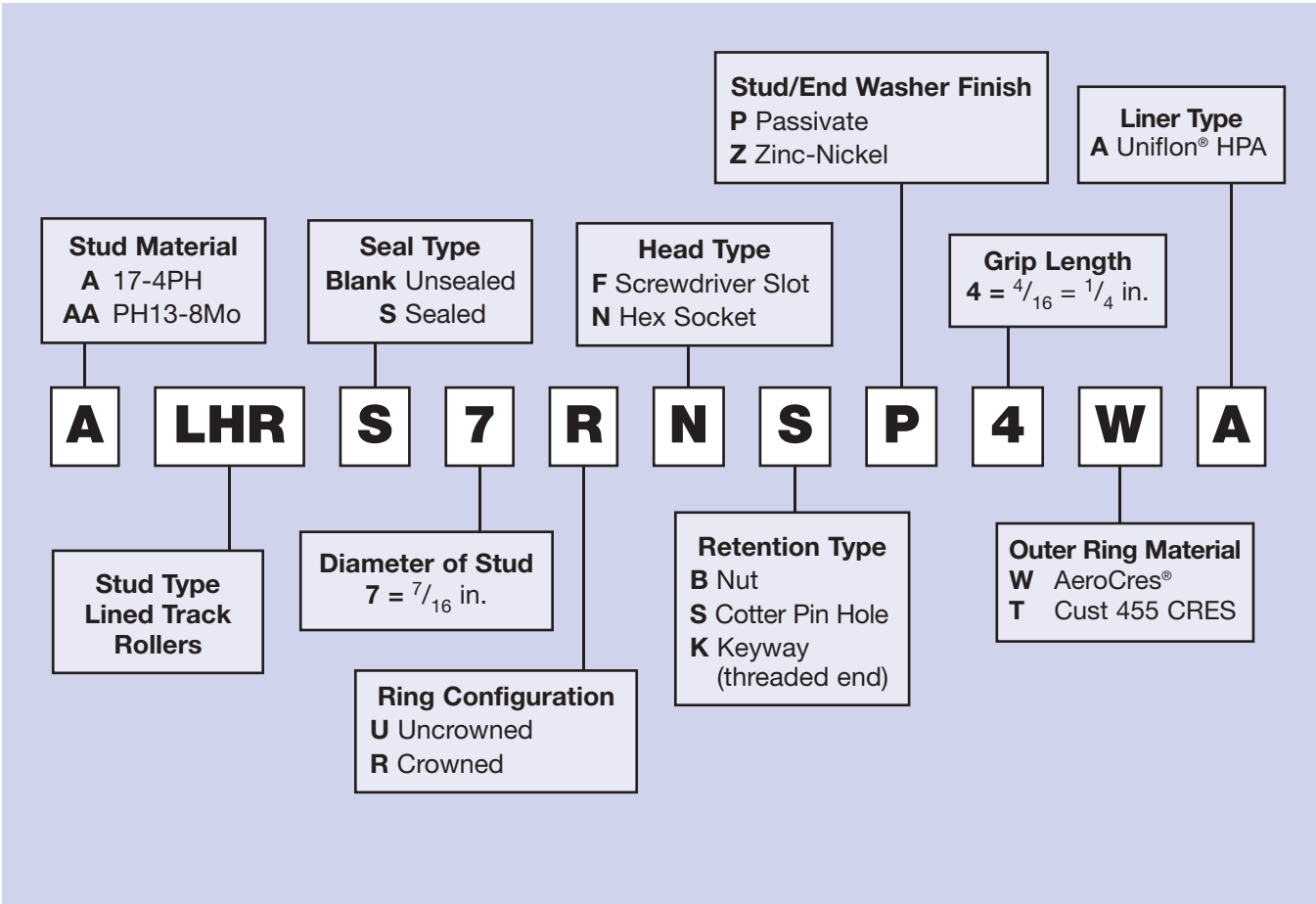
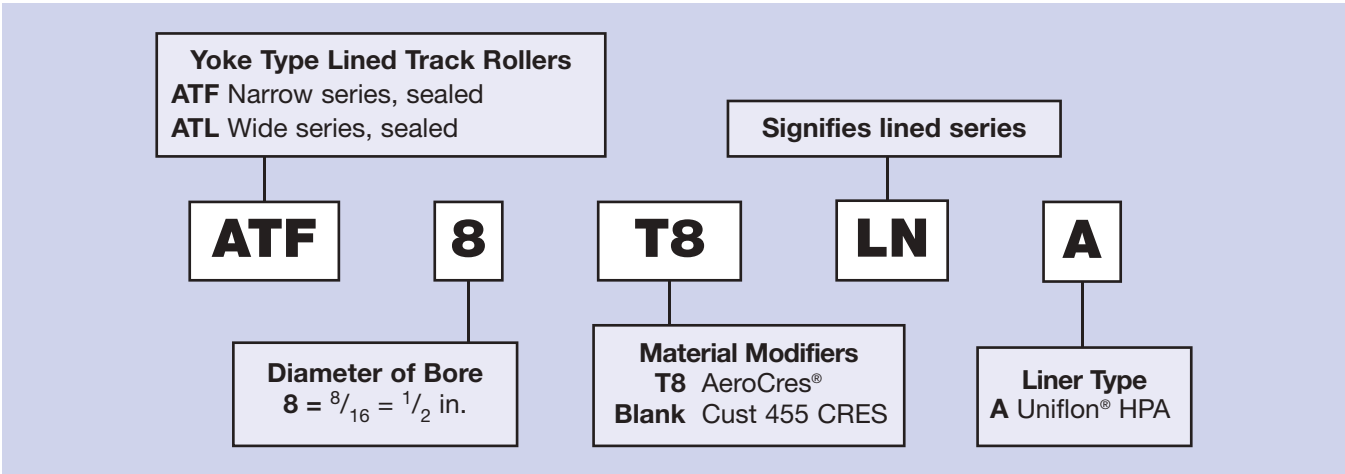

AIRFRAME CONTROL LINED ROLLER BEARINGS

INTRODUCTION

The bearings described in this section of the catalog have been designed to meet the specific needs of the airframe industry.

Self-lubricating track roller bearings provide a maintenance-free solution to eliminate the need to grease the bearings and/or provide a solution for applications with space limitations which make servicing and maintaining an individual bearing unfeasible.

The advanced polymer resin liner system contains self-lubricating additives to yield a high strength, low wear, and low

friction bearing material. This liner is bonded to the inner raceway and carries the load while a specially prepared outer ring mating surface keeps friction at a reasonable level and minimizes liner wear.

Aircraft lined track rollers exhibit a coefficient of friction that typically ranges between 0.02 and 0.14 depending on the applied load, operating temperature, motion, and contamination.

Before selecting specific airframe lined track roller bearings, the service and performance requirements should be reviewed with an RBC Aerospace Bearings sales engineer to select the correct bearing type for the application.

PERFORMANCE CALCULATIONS

The evaluation of the lined track roller bearing is based on the liner pressure and the coefficient of friction.

Liner Pressure $\sigma = F_N / A$

where F_N = Normal Force (Radial Load)
 $A = \phi \times w$ = Liner OD x Liner Effective Width
 = (Projected Area)

Coefficient of Friction $\mu = F_f / F_N$

where F_f = Frictional Force = τ / r_{OR}
 τ = Rotational Torque
 r_{OR} = Outer Ring Radius

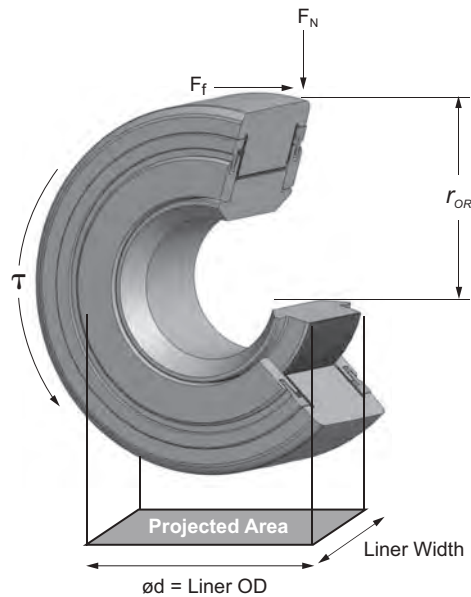

BEARING APPLICATIONS

Examples of typical applications for self-lubricating bearings include:

- Passenger and cargo doors
- Landing gear / landing gear doors
- Leading edge support and side guides for slats
- Trailing edge carriages for flaps
- Trailing edge anti-vibration for flaps

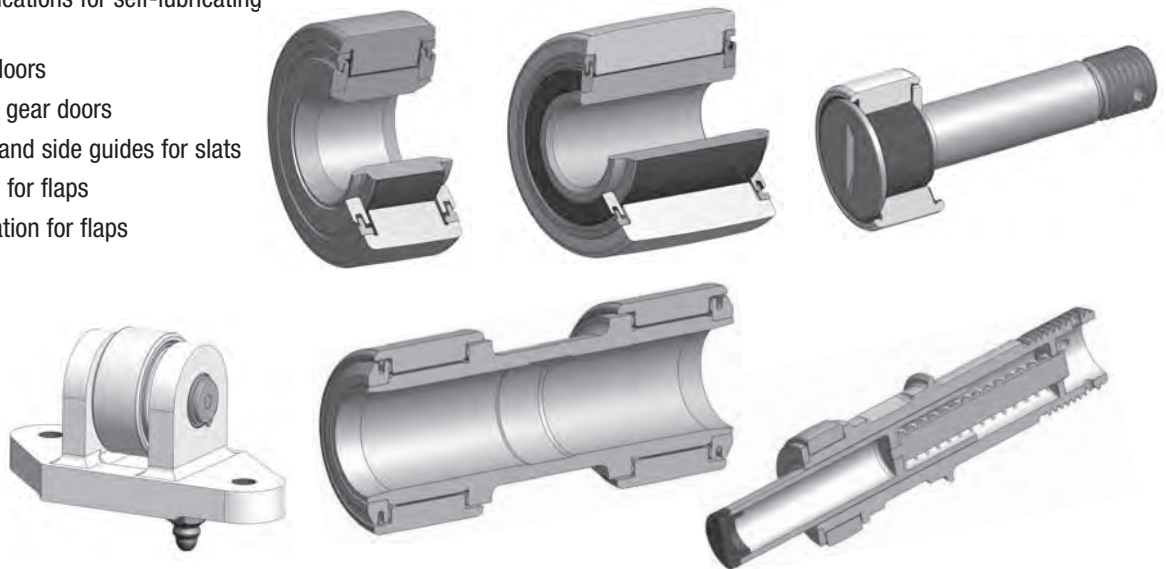

AIRFRAME CONTROL LINED ROLLER BEARINGS

GENERAL

- Comprised of outer, inner, washers, and seals.
- Uniflon® HPA liner on inner ring raceway and outer ring thrust surfaces.
- Crowned outer ring
- Radial Internal Clearance: 0.0015 - 0.0035"
- Axial Internal Clearance: 0.005 - 0.015"

MATERIALS

- Outer Ring: Custom 455 CRES or AeroCres®
- Inner Ring: 17-4PH or PH13-8Mo CRES
- Washers: 17-4PH or PH13-8Mo CRES
- Seals: Acetal copolymer
- Liner: Uniflon® HPA liner (inner ring raceway and outer ring thrust faces)



ATF-LNA

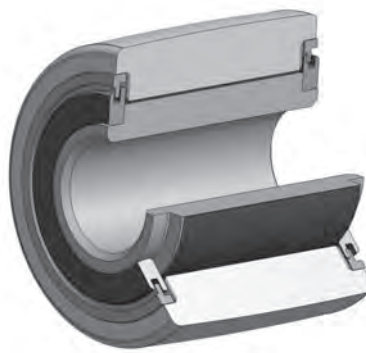

ATL-LNA

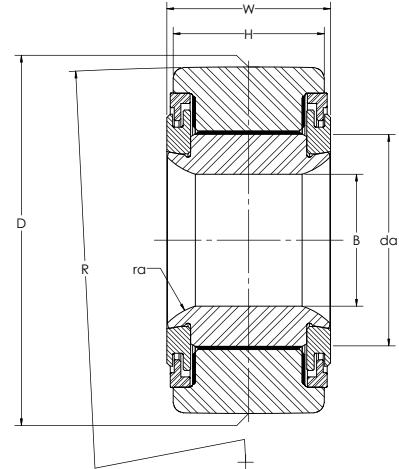

SPECIFICATIONS AND ORDERING INFORMATION

BEARING DIMENSIONS

Bearing Designation	B Bore		D O.D.		W Widths				H		ra Shaft Fillet (max.)	R Crown Radius (ref.)		Weight (approx.)		da Clamping Dia (min.)		Radial Static Limit Load ⁽¹⁾	
	+0.00	+0.00	+0.01	+0.025	+0.00	+0.0	+0.00	+0.0	in.	mm		in.	mm	lbs	kgs	in.	mm	lbf	N
	-0.007	-0.018	-0.001	-0.025	-0.010	-0.25	-0.010	-0.25											
ATF-3-LNA	0.1900	4.826	0.7500	19.05	0.312	7.92	0.280	7.11	0.022	0.56	11	279	0.030	0.01	0.438	11.13	3,700	832	
ATF-4-LNA	0.2500	6.350	0.8750	22.23	0.375	9.53	0.345	8.76	0.022	0.56	11	279	0.051	0.02	0.516	13.11	5,700	1,281	
ATF-6-LNA	0.3750	9.525	1.0625	26.99	0.500	12.70	0.455	11.56	0.022	0.56	11	279	0.103	0.05	0.672	17.07	12,300	2,765	
ATF-8-LNA	0.5000	12.700	1.3125	33.34	0.625	15.88	0.580	14.73	0.032	0.81	13	330	0.187	0.08	0.844	21.44	21,800	4,901	
ATF-10-LNA	0.6250	15.875	1.5000	38.10	0.750	19.05	0.705	17.91	0.032	0.81	18	457	0.279	0.13	0.953	24.21	28,300	6,362	
ATF-12-LNA	0.7500	19.050	1.7500	44.45	1.000	25.40	0.950	24.13	0.032	0.81	31	787	0.520	0.24	1.109	28.17	50,800	11,420	
ATF-14-LNA	0.8750	22.225	2.0000	50.80	1.125	28.58	1.075	27.31	0.032	0.81	36	914	0.749	0.34	1.219	30.96	67,700	15,219	
ATF-16-LNA	1.0000	25.400	2.2500	57.15	1.125	28.58	1.075	27.31	0.032	0.81	27	686	0.931	0.42	1.500	38.10	72,000	16,186	
ATL-4-LNA	0.2500	6.350	0.8750	22.23	0.750	19.05	0.710	18.03	0.022	0.56	11	279	0.107	0.05	0.576	14.63	14,600	3,282	
ATL-6-LNA	0.3750	9.525	1.1250	28.58	1.000	25.40	0.940	23.88	0.022	0.56	11	279	0.239	0.11	0.672	17.07	29,800	6,699	
ATL-8-LNA	0.5000	12.700	1.3750	34.93	1.250	31.75	1.190	30.23	0.032	0.81	13	330	0.437	0.20	0.891	22.63	50,300	11,307	
ATL-10-LNA	0.6250	15.875	1.6250	41.28	1.500	38.10	1.440	36.58	0.032	0.81	18	457	0.728	0.33	1.109	28.17	76,000	17,085	
ATL-12-LNA	0.7500	19.050	1.8750	47.63	1.750	44.45	1.690	42.93	0.032	0.81	31	787	1.130	0.51	1.281	32.54	107,000	24,054	
ATL-14-LNA	0.8750	22.225	2.1250	53.98	2.000	50.80	1.940	49.28	0.032	0.81	36	914	1.630	0.74	1.469	37.31	138,200	31,067	
ATL-16-LNA	1.0000	25.400	2.3750	60.33	2.250	57.15	2.190	55.63	0.032	0.81	27	686	2.310	1.05	1.578	40.08	179,100	40,262	

(1) Radial static load calculated based on liner capacity only.

AIRFRAME CONTROL LINED ROLLER BEARINGS

GENERAL

- Comprised of outer, stud, washer, and seals (optional).
- Uniflon® HPA liner on inner ring raceway and outer ring thrust surfaces.
- Crowned outer ring
- Radial Internal Clearance: 0.0015 - 0.0035"
- Axial Internal Clearance: 0.005 - 0.015"

MATERIALS

- Outer Ring: Custom 455 CRES or AeroCres®
- Stud: 17-4PH or PH13-8Mo CRES
- Washers: 17-4PH or PH13-8Mo CRES
- Seals: Acetal copolymer
- Liner: Uniflon® HPA liner (stud raceway and outer ring thrust faces)

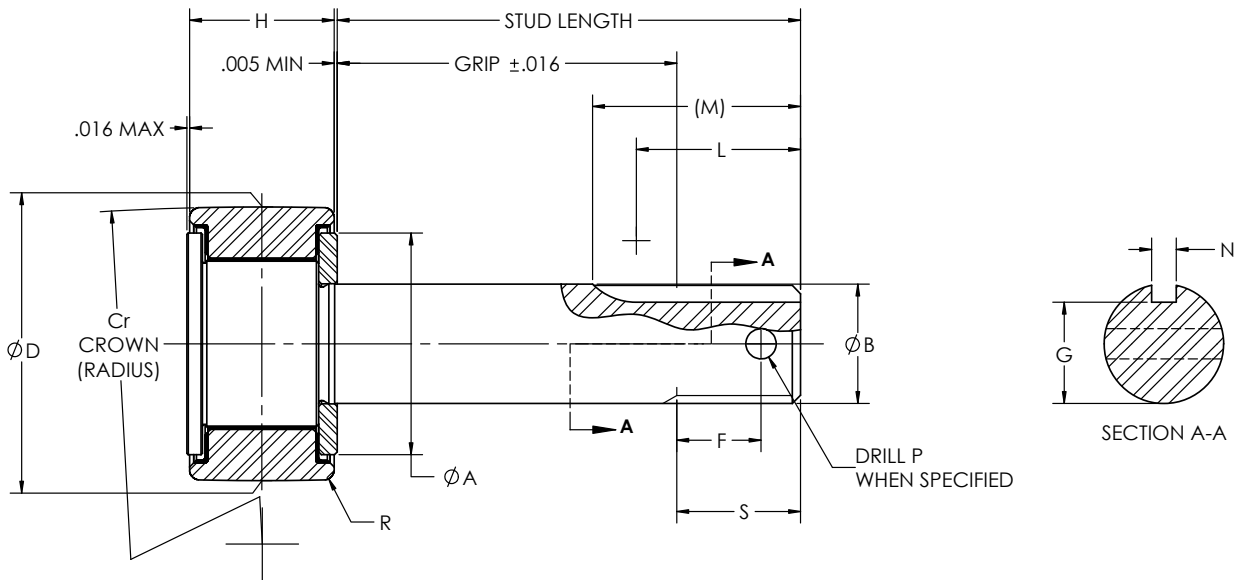
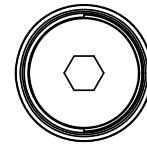
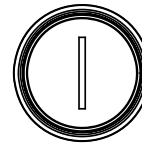
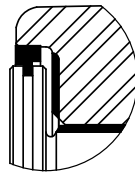
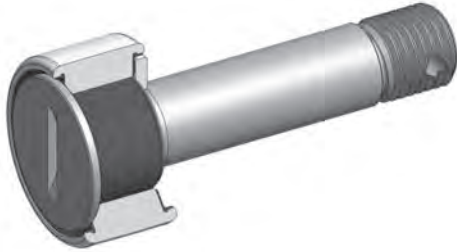

AIRFRAME CONTROL LINED ROLLER BEARINGS

SPECIFICATIONS AND ORDERING INFORMATION

BEARING DIMENSIONS

SIZE CODE	D		B		A	H		Cr	R	S (Threads)		F	P	Keyway				Radial Static Limit Load ⁽¹⁾	Stud Radial Static Limit Load	Track Capacity 180 ksi Steel	Install Torque Max - Lub. Threads
	Outer Diam.	Stud Diam.	Stud Diam.	Clamp Diam.	Outer Width	Crown	Corner Rad	Length	Size	Cotter Pin Hole	L	M	N	G	lb	lb	lb				
Tol.	+.001 -0.005	+.025 -0.013	+.000 -0.001	+.000 -0.025	(approx.)	+.000 -0.005	+.000 -0.013	(ref.)	(ref.)	(ref.)	(AS8879)	(min.)	+.010 -0.000	+.030 -0.000	(ref.)	±.0020	±.0030				
	in.	mm	in.	mm	in.	in.	mm	in.	in.	in.		in.	in.	in.	in.	in.	in.	in.	in.	in.	in.
3	0.5000	12.70	0.190	4.83	0.400	0.281	7.14	6	0.01	0.334	.1900-32	0.211	0.07	NA	NA	NA	NA	2950	710	385	8
4	0.6875	17.46	0.250	6.35	0.570	0.281	7.14	6	0.01	0.334	.2500-28	0.224	0.076	0.375	0.534	0.0635	0.2143	3650	1310	525	20
5	0.7500	19.05	0.312	7.92	0.590	0.344	8.74	7	0.02	0.359	.3125-24	0.234	0.076	0.390	0.546	0.0635	0.2738	5500	2110	725	40
6	0.8750	22.23	0.375	9.53	0.720	0.469	11.91	8	0.02	0.359	.3750-24	0.265	0.106	0.390	0.572	0.0947	0.3236	10000	2950	1100	55
7	1.0000	25.40	0.437	11.10	0.840	0.531	13.49	10	0.02	0.422	.4375-20	0.283	0.106	0.453	0.635	0.0947	0.3861	13500	4785	1475	155
8	1.1250	28.58	0.500	12.70	0.970	0.656	16.66	12	0.02	0.422	.5000-20	0.314	0.106	0.453	0.662	0.126	0.433	20900	5490	1975	205

(1) Radial static load calculated based on liner capacity only.

RBC Thin Section Ball Bearings

PRODUCT NOMENCLATURE	110	Angular Contact, A-Type Series	132-137
Thin Section Ball Bearings Type	111	4-Point Contact, X-Type Series	138-143
Thin Section Ball Bearings Separator Guide	112	Sealed Radial Contact, C-Type Series	144-145
Engineering Section		Sealed 4-Point Contact, X-Type Series	146-147
for Thin Section Ball Bearings	113-121	SuperDuplex™ Series	148-149
Thin Section Ball Bearings Tolerance and Fits	122-124	Y-PWI (Duplex) Series	150
Thin Section Ball Bearings Tables	125	Thermal-Comp®	151
Radial Contact, C-Type Series	126-131	Custom Bearing Applications	152-165

GENERAL FEATURES AND TECHNICAL SPECIFICATIONS

Seals and Shields

Standard seals for thin section ball bearings are molded from elastomers. PTFE seals, fiber glass reinforced PTFE seals, stainless steel shields, and many other options are available for low torque and other special applications.

Materials

Rings are made from SAE 52100, M50, 17-4PH, 440C, aluminum and other specialty bearing steels to provide corrosion resistance, high temperature capability, alternative load capacity, or chemical compatibility. Surfaces can be coated with cadmium, zinc nickel, or nodular thin dense chrome (TDC) as required by application.



Separators

Some options include snap-over cage, one-piece ring circular pocket, wire cage, spacer balls, slugs, or helical coil springs. Materials include phenolic laminates, nylon, brass, composite, stainless steel, and ceramics, to name a few.

Balls

Some special ball materials available include 52100, CRES 440C, 300 series stainless steel, silicon nitride, M50, and ceramic balls.

Construction

Available in single and double row construction to accommodate different load requirements. Mounting features, such as flanges, anti-rotation tabs, and mounting holes can be incorporated on the rings. ing of the duplex bearing can be customized to meet application needs.

Nomenclature

EXAMPLE	K	A	1	2	0	X	P	0	M*	RBC
NOMENCLATURE	Material	Series	Size			Type	Separator	Precision	Radial Play	
Position	1	2	3	4	5	6	7	8	9**	

Position 1: Material (& seal/shield options)

	Material		Seals, Shields	Coating
	Rings	Balls		
A	52100		1 seal – PTFE	No
B	52100		2 seals – PTFE	No
D	52100		1 shield	No
E	52100		2 shields	No
F	52100		1 seal – PTFE seal & shield	No
G	52100		2 seals – PTFE seal & shield	No
H	52100		1 seal – molded rubber	No
J	52100		2 seals – molded rubber	No
K	52100		No seals or shields	No
L	52100	440C	2 combo – PTFE seal & shield	Thin Dense Chrome
M		M-50	No seals or shields	No
N	52100	440C	No seals or shields	Thin Dense Chrome
P	17-4PH Steel		No seals or shields	No
Q	52100 Steel		No seals or shields	No
R	52100	440C	No seals or shields	Zn Nickel plating
S	440C		No seals or shields	No
T	440C		1 seal – PTFE	No
U	440C		2 seals – PTFE	No
V	440C		2 seals	No
W	440C		2 seals – molded rubber	No
X	52100	Ceramic	No seals or shields	No
Y	440C	Ceramic	Ceramic balls	No
Z		Other		

Position 6: Type
See Page 111

Position 7: Ball Separators
See Page 112

Position 8: RBC Precision Class

Class	Description
0	ABEC 1F
3	ABEC 3F
4	ABEC 5F
6	ABEC 7F

Reference: ANSI/ABMA Std 26.2

Position 2: Series

Ball Dia (d)	Standard Width	W (=2d)	Position 3, 4, 5: Size		Extra Extended Width	W _{FF} (>2d)
			Extended Width (5)	W _F (>2d)		
3/32	AA	.1875	HA	.2500	SA	.3125
1/8	A	.2500	H	.3125	S	.3750
5/32	B	.3125	I	.3750	T	.4375
3/16	C	.3750	J	.4375	U	.5000
1/4	D	.5000	K	.5781	V	.6563
3/8	F	.7500	M	.8750	X	1.0000
1/2	G	1.0000	N	1.1875	Y	1.3750

Bore Size (Inches) Multiplied by 10
Examples:
030 = 3.00" BORE
075 = 7.50" BORE
250 = 25.00" BORE

Position 9: Bearing Assembly Clearance or Tightness

Diametral Clearance (Positive Radial Play)		Radial Tightness (Negative Radial Play)		Axial Gap (Duplex BRG)	
A	+.0000 to +.0005	K	-.0000 to -.0005	K	+.0000 to +.0005
B	+.0000 to +.0010	L	-.0000 to -.0010	L	+.0005 to +.0010
C	+.0005 to +.0010	M	-.0005 to -.0010	M	+.0005 to +.0010
D	+.0005 to +.0015	N	-.0005 to -.0015	N	+.0005 to +.0015
E	+.0010 to +.0020	P	-.0010 to -.0020	P	+.0010 to +.0020
F	+.0015 to +.0025	R	-.0015 to -.0025	R	+.0015 to +.0025
G	+.0020 to +.0030	S	-.0020 to -.0030	S	+.0020 to +.0030
H	+.0030 to +.0040	T	-.0030 to -.0040	T	+.0030 to +.0040
I	+.0040 to +.0050	U	-.0040 to -.0050	U	+.0040 to +.0050
J	+.0050 to +.0060	Z	Per Variation Log	Z	Per Variation Log
O	Match for Normal Radial Play				

*The alphanumeric identification system is used under license.

**Position 9 only required when designating special radial play. Standard Radial play is shown in tolerance tables, pages XX-XX.

Note: Radial preloaded bearings meet bore and O.D. tolerances prior to preload.

THIN SECTION BALL BEARINGS

THIN SECTION BALL BEARINGS TYPE

Position 6: Type		LOAD CONDITION				
Bearing Type	Ball Contact	Radial	Axial	Moment	Reversing Axial	Combined Radial, Axial & Moment
C	Radial	Good	Fair	Poor	Fair	Poor
A	Angular	Good	Very Good	Do not use	Do not use	Do not use
X	4-Point	Fair	Good	Good	Good	Fair
B	Double Angular	Very Good	Very Good	Very Good	Very Good	Good
F	Double Angular	Very Good	Very Good	Very Good	Very Good	Good
T	Double Angular	Very Good	Excellent	Do not use	Do not use	Do not use
M	Double Angular	Excellent	Excellent	Excellent	Excellent	Excellent
W	Double Angular	Excellent	Excellent	Excellent	Excellent	Excellent

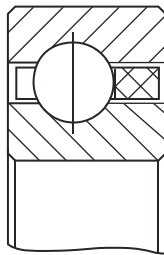

C-Type
(Radial Contact)

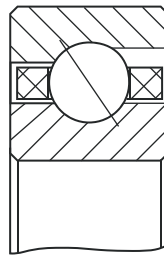

A-Type
(Angular Contact)

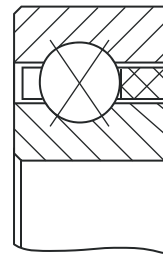

X-Type
(4-Point Contact)

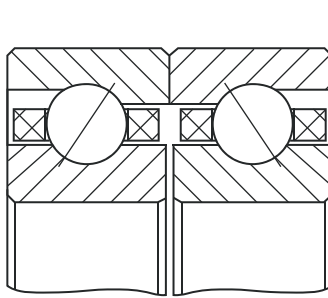

B-Type
Duplex Back-to-Back (DB)

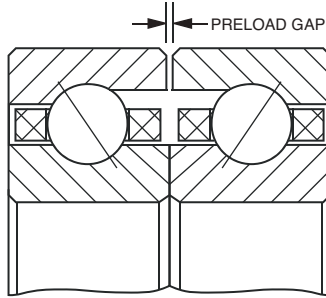

F-Type
Duplex Face-to-Face (DF)

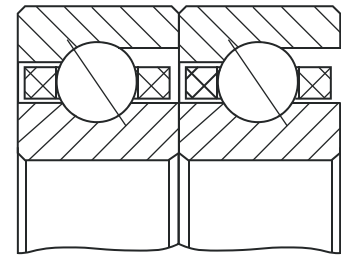

T-Type
Duplex Tandem (DT)

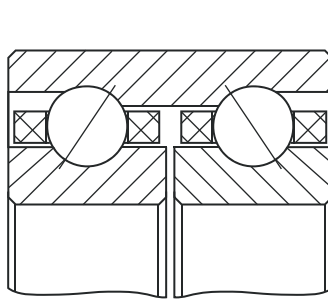

M-Type
SuperDuplex™ Back-to-Back

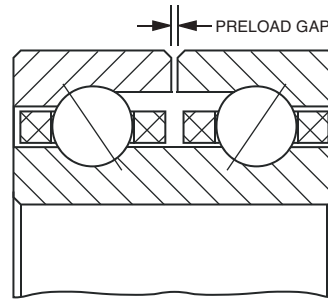

W-Type
SuperDuplex™ Face-to-Face

THIN SECTION BALL BEARINGS SEPARATOR GUIDE

Position 7: Separators								
Bearing Type	CLOSED RING			ONE STRIP OR SEGMENTS				
	CAGE DESIGN FEATURES							
	SHAPE	FABRICATION METHOD	POCKET RETENTION	ADVANTAGE LIMITATIONS		MATL/TYPE CODE		
C-Type & X-Type	ONE STRIP or SEGMENTS	MOLDED		Higher ball count. Available for all diameters over 4". Recommended for operating temperature range: -40° to 210°F		N Nylon P12 C Composite		
	CLOSED RING	MACHINED				Low torque and light weight applications. Can be oil impregnated as required. Not recommended for high speed or high temperatures.		D Phenolic
		MOLDED		Low torque and light weight applications. High speed limits. Not recommended for temperatures outside -65° to 250°F range.				L GFR Nylon
	SEGMENTS	STAMPED, FORMED and BRAZED				Ideal for commercial applications with moderate torque and speed requirements. Not recommended for low torque applications		Q PEEK
	CLOSED RING			ONE-PIECE DIE-FORMED	Ideal for commercial applications with moderate torque and speed requirements. Not recommended for low torque applications			E Brass P Brass or (Composite)
	1 STRIP or SEGMENTS	FORMED WIRE		High strength, improved corrosion resistance. High temperature capabilities. Not recommended for low torque applications			U CRES	
						Ideal for applications with moderate torque and high speed. Limited availability		V Brass
A-Type	ONE STRIP or SEGMENTS	MOLDED		Higher ball count. Available for all diameters over 4". Recommended for operating temperature range: -40° to 210°F		J Nylon P12 C Composite		
	CLOSED RING	MACHINED				Higher ball count. Available for all diameters over 4". Recommended for operating temperature range: -40° to 210°F		H Phenolic
		MOLDED		Low torque and light weight applications. Can be oil impregnated as required. Not recommended for temperatures above 250°F				G GFR Nylon
	SEGMENTS	STAMPED, FORMED and BRAZED				Low torque and light weight applications. High speed limits. Not recommended for temperatures outside of -65° to 250°F range.		Q Peek
	CLOSED RING			ONE-PIECE DIE-FORMED	Ideal for commercial applications with moderate torque and speed requirements. Not recommended for low torque applications			E Brass
							Ideal for commercial applications with moderate torque and speed requirements. Not recommended for low torque applications	
				High strength, improved corrosion resistance. High temperature capabilities. Not recommended for low torque applications		U CRES		
				Ideal for applications with moderate torque and high speed. Limited availability		V Brass		
				High torque, low speed, and light weight applications. Not intended for use in high speed applications		M Spring Steel or CRES		
A-Type, C-Type & X-Type	PER PIECE	SLUGS; MOLD or MACHINED TUBES		Low torque applications, higher capacity than standard bearing. Not intended for use in high speed applications. Material may have temperature limitations.		S PTFE/PFA K PEEK		
		SPACER BALLS				High temperature applications, offers higher resistance to wear. Lower load capacity in A-type bearings		Z Various
		TOROIDS						Low torque applications, higher capacity than standard bearing. Not intended for use in high speed applications. Material may have temperature limitations.
	N/A	FULL COMP		Highest loading capacity and maximum stiffness. Higher torque and lower speed limits. Not recommended for low torque and/or high speed.		F N/A		

ITB does not supply "one-piece" closed molded (P- & R-) Cages. We sell strip N-Cages as P-Cages, and J-Cages as R-Cages.

THIN SECTION BALL BEARINGS

THIN SECTION BALL BEARING ENGINEERING DATA

The methods, equations, and technical data presented in this section allow the user to select the correct bearings and estimate their performance for a wide range of applications. For applications with severe or unusual operating conditions, RBC is prepared to provide an in-depth analysis and recommend the most suitable bearing arrangement.

Where standard bearings cannot be used, RBC can meet the application requirements with a special bearing design specifically tailored for optimum performance. Questions concerning information in this section should be directed to the appropriate RBC Aerospace Bearings sales engineer.

Capacity and Fatigue Life of Ball Bearings

The **basic dynamic radial load rating**, C, or “dynamic capacity,” for a ball bearing is the calculated, constant radial load at which 90% of a group of apparently identical bearings with stationary outer rings can statistically endure 10^6 revolutions of the inner ring. ANSI/ABMA Standard 9 with correction factors for race curvatures was used to calculate the catalog ratings.

The **dynamic thrust** and **dynamic moment load ratings** are also shown in the product tables. The ratings shown are a guide for the maximum loads under which these bearings should be operated with either pure thrust or pure moment loading. Thrust ratings are 2.5 to 3.0 times the radial ratings depending on the bearing type and cross-section. These load ratings are not additive. For combined radial and thrust loads, an equivalent radial load is to be calculated.

The **basic static load rating**, C_0 , or “static capacity,” is that uniformly distributed load, which produces a maximum theoretical contact stress of 609,000 psi. At this contact stress, permanent deformation of ball and raceway occurs. This deformation is approximately .0001% of the ball diameter.

The **rating life**, L_{10} , is a statistical measure of the life which 90% of a large group of apparently identical ball bearings will achieve or exceed. For a single bearing, L_{10} also refers to the life associated with 90% reliability. Median life, L_{50} , is the life that 50% of the group of ball bearings will achieve or exceed. Median life is approximately five times the rating life.

The relationship between rating life, load rating, and load is:

$$L_{10} = (C/P)^3 \text{ with } L_{10} = \text{rating life (} 10^6 \text{ rev)}$$

$$C = \text{basic dynamic radial load rating (lbf)}$$

$$P = \text{equivalent radial load (lbf)}$$

To obtain the rating life in hours, use:

$$L_{10 \text{ hrs}} = 16667/N * (C/P)^3 \text{ with } N = \text{speed (rpm)}$$

The equivalent radial load is defined as:

$$P = XF_r + YF_a \quad \text{with} \quad \begin{array}{l} F_r = \text{radial load (lbf)} \\ F_a = \text{axial load (lbf)} \\ X - \text{see below} \\ Y - \text{see below} \end{array}$$

Radial Contact Bearing Calculations

For radial contact bearings calculate P with $X = 1$ and $Y = 0$. Then recalculate P with $X = 0.56$ and $Y =$ (see chart below). Use the larger value of P to determine L_{10} life.

$\frac{F_a}{nd^2}$	Y
25	2.30
50	1.99
100	1.71
150	1.55
200	1.45
300	1.31
500	1.15
750	1.04
1000	1.00

n = number of balls
 d = diameter of balls (in.)

Angular or 4-Point Contact Bearing Calculations*

For angular contact and 4-point contact bearings calculate P with X = 1.0 and Y = 0. Then recalculate P with X = 0.39 and Y = 0.76. Use the larger value of P to determine L₁₀ life.

The equations are valid in the range of approximately 100 hrs to 100,000 hrs of life. Extreme loads or speeds may result in a shorter life; while in less demanding applications, metal fatigue may never affect bearing service life.

*Capacity and fatigue life information is based on ANSI/ABMA Standard 9-1990 published by: The American Bearing Manufacturers Association, Inc., 1200 19th Street, NW, Suite 300, Washington, DC 20036-2401

Adjustment Factors for Rating Life

If a bearing design and operation deviates significantly from normal, it may be necessary to use additional factors to estimate the fatigue life L_n.

$$L_n = a_1 * a_2 * a_3 * L_{10hrs}$$

- with a₁ = reliability factor
- a₂ = material and processing factor
- a₃ = application factor

Reliability Factor a₁

Reliability is the percentage of a group of apparently identical ball bearings that is expected to attain or exceed a specified life. For an individual bearing it is the probability that the bearing will attain or exceed a specified life. Typical bearing fatigue life is calculated for 90% reliability. The life adjustment factors for other reliability numbers are shown below.

Reliability %	L _n	Reliability Factor a ₁
90	L ₁₀	1.00
95	L ₅	.62
96	L ₄	.53
97	L ₃	.44
98	L ₂	.33
99	L ₁	.21

Material Factor a₂

For standard bearings, the material factor a₂ is equal to 1.00. Factor a₂ is determined by material processing, forming methods, heat treatment, and other manufacturing methods. Some commonly used material factors are listed below:

Material, Condition	a ₂ max
52100, Air melt	1.00
52100, Vacuum degassed	1.50
52100, Air melt and TDC Plate	2.00
52100, Vacuum melt, (CEVM)	3.00
440C, Air melt	1.00
440C, Vacuum melt (CEVM)	3.00
M50, Vacuum melt (CEVM)	5.00
M50, Vacuum re-melt (VIM-VAR)	8.00

Application Factor a₃

The application factor a₃ is equal to 1.0 for most applications. Unusual or extreme conditions in certain applications such as low speed, shock loading, vibration, and extreme temperature may lower the application factor to 0.50. Contact an RBC Aerospace Sales Engineer for help in determining this factor for special applications.

Load Limitations

The load ratings shown in the product tables are not additive. For combined simultaneous loading, an equivalent radial or thrust load must be considered. In general, C-Type bearings are designed for radial loading applications; moderate thrust and/or moment loading may be applied in combination with radial loading. For thrust loading applications use the A-Type bearing; any radial loading should only be applied in combination with thrust loading. X-Type bearings are primarily for reversing thrust and moment loading, pure radial loading should not be applied.

Speed Limitations

The limiting speeds are based on standard lubrication. The unsealed bearing speeds are calculated assuming the bearings are lubricated with MIL-PRF-6085. Limiting speeds for sealed bearings are calculated assuming the bearings are lubricated with MIL-PRF-23827 grease. If bearings are lubricated with alternate oils or greases, new limiting speeds must be calculated, see page 115.

OPERATING CONDITIONS

Lubrication

Lubricants serve a number of very important purposes in ball bearings, including:

- protecting bearing surfaces from corrosion
- reducing rolling and sliding friction
- preventing metal-to-metal contact between balls and raceway
- providing a barrier against external contaminants (grease)
- removing heat (oil)

Lack of lubrication or inadequate lubrication is the most common cause of bearing failure.

Standard RBC thin section ball bearings are lubricated with either oil or grease. The unsealed bearings, the K series, are thoroughly coated in MIL-PRF-6085 oil and drained of excess. Sealed bearings are lubricated with MIL-PRF-23827 grease. The external surfaces of sealed bearings are lightly coated with the same grease for corrosion resistance. Additional lubricants are also available. An RBC Aerospace Sales Engineer can help select the appropriate lubricant for special applications.

Temperature

Standard RBC thin section ball bearings can operate at temperatures from -65°F to +250°F. Temperatures up to 350°F can be reached if the bearings are temperature stabilized. By the use of special materials RBC can provide bearings for operation to 900°F. Contact an RBC Aerospace Bearings sales engineer for recommendations on bearings operating above 250°F.

Limiting Speed

The limiting speed of a bearing is dependent upon a number of different factors including bearing size, bearing type, ball separator design, lubrication and loading. The limiting speeds for the bearings shown in this catalog are determined using the following:

$$N = \frac{1000 * k}{E} \text{ with } N = \text{Speed (RPM)}$$

$$E = \frac{D+B}{2} \text{ (Bearing pitch diameter)}$$

k = constant, see table below

Bearing Type	Load Condition	k Value	
		Grease	Oil
C or A	Radial or Thrust	16	20
X	Thrust	10	12
X	Radial, Combined Radial & Thrust, or Moment	3	4

© 2008, 2011, 2018 RBC Bearings Incorporated. All rights reserved.

The “ k ” values shown give the maximum speeds at which a typical thin section ball bearing can operate. It is recommended that operating speeds of large diameter bearings in a given series be reduced up to 40% of the calculated rating to avoid high bearing temperatures. Speed ratings can also be impacted by load conditions, lubrication, alignment, and ambient temperature. All of these factors must be considered when designing thin section ball bearings into your application.

DUPLEX PAIRS AND AXIAL PRELOADING

Duplex Pairs

Duplex bearings are a pair of angular contact RBC thin section ball bearings specially ground for use as a matched set. A duplexed pair can be used to provide accurate shaft location, to increase capacity or to increase stiffness of the bearing assembly. A duplex pair of RBC thin section ball bearings is ground so that when mounted using recommended fits, there will be no internal clearance in the bearings. There are three basic mounting methods to accommodate different loading requirements:

- Back-to-Back (DB), B-Type
- Face-to-Face (DF), F-Type
- Tandem (DT), T-Type

Back-to-Back, DB
B-Type

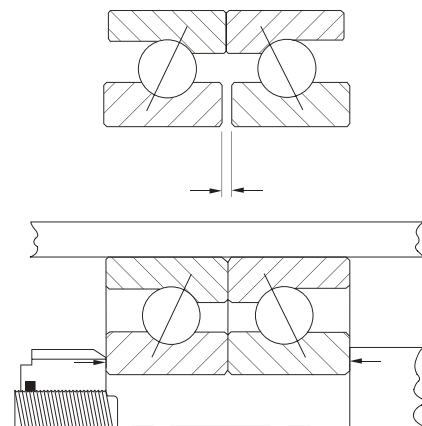

- Heavy radial loads
- Combined thrust and radial loads
- Reversing thrust loads
- Excellent rigidity
- Moment loads

Face-to-Face, DF
F-Type

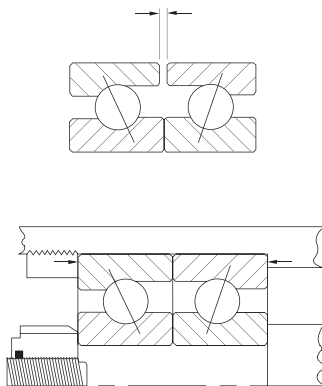

- Heavy radial loads
- Combined thrust and radial loads
- Reversing thrust load
- Moment loads

Tandem, DT
T-Type

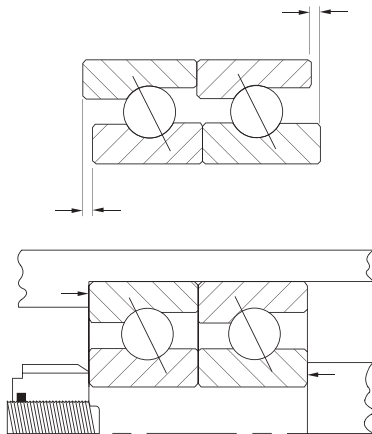

- High one-direction thrust loads
- Minimum axial shaft deflection
- Heavy radial loads

Axial Preloading

Standard duplex bearings are ground so that there will be a light axial preload induced on the bearing at nominal conditions. In some applications increased bearing stiffness may be required. In these cases the duplex grinding can be done such that a heavier axial load is induced in the mounted bearing. This load can be increased or decreased to meet the requirements of a particular application. Consult an RBC Aerospace Bearings sales engineer for special requirements.

Radial Play

Radial play (diametral clearance) is the distance the inner ring can be moved radially from one extreme position to the other. Standard RBC thin section ball bearings are manufactured with enough radial play that some clearance remains after the bearing is properly installed.

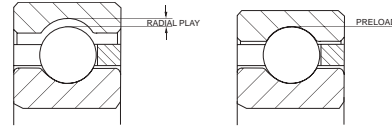

When there is negative radial play (diametral preload) there is interference rather than clearance between the balls and the races. As the interference increases, the friction, stiffness and torque also increase. RBC thin section ball bearings can be manufactured with customer specified diametral preload or clearance. Consult an RBC Aerospace Bearings sales engineer for design assistance.

Radial and Axial Runout

Radial runout of RBC thin section ball bearings is a measurement of the thickness variation of the bearing rings. The outer ring is measured from the ball path to the outer diameter of the ring, the inner ring is measured from the ball path to the bore. Radial runout is defined as the wall thickness variation of the rotating ring.

Axial runout is measured from the ball path to the face of the bearing rings. The variation in thickness measured is the axial runout.

TOLERANCES

Precision Grades

RBC thin section ball bearings are available in four precision grades. RBC precision classes 0, 3, 4, and 6 correspond to ABMA ABEC grades 1F, 3F, 5F, and 7F respectively. The tolerances for the bearing bores, outer diameters, radial runouts, axial runouts, and radial plays are shown in the Tolerance Tables on pages 122 – 124.

Shaft and Housing Fits

Proper shaft and housing fits are critical to the successful operation of a thin section ball bearing. The internal clearance of the bearing will be reduced proportionally by an interference fit. In addition, the roundness of the shaft and housing will directly affect the roundness of the inner and outer ring raceways. For most applications, the inner ring is rotating and the load is stationary with respect to the outer ring. In this circumstance, a light press fit onto the shaft is recommended. The recommended shaft and housing fits are shown in the Tolerance Tables on pages 122 – 124.

MOUNTING ARRANGEMENTS

When selecting a mounting arrangement for RBC thin section ball bearings, you must first consider the loading condition. A duplex pair of angular contact bearings may be used for combined loading, moment loading, or heavy thrust loading. Combination A and C-Type, A and X-Type, or C and X-Type bearings are common mounting arrangements. Two X-Type bearings should never be mounted on the same shaft. There may be many different bearing arrangements for carrying the same load. Some typical mounting arrangements are shown below.

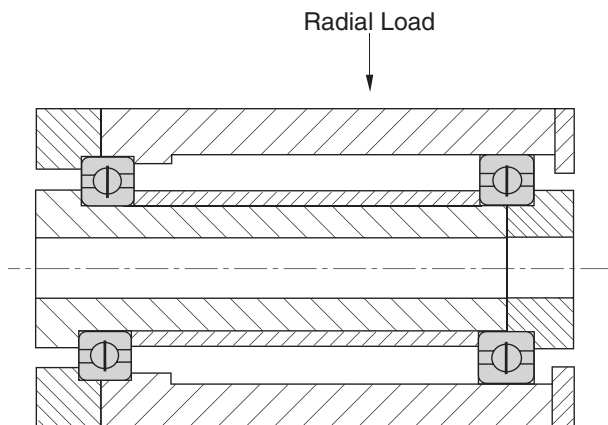

Heavy Radial Loads

The C-Type bearing is designed primarily for heavy radial loads. Two bearings can be installed on the same shaft as shown. By axially fixing one bearing and allowing the other to float, this configuration allows differential expansion between the housing and shaft, such as caused by temperature difference, without adding axial stress to the bearings. Although the C-Type bearing is designed for radial loads, they can withstand moderate thrust, moment, and reversing loads.

Reversing Loads

The duplex pair of A-Type bearings offers several configurations. For reversing loads, either back-to-back, B-Type, or face-to-face, F-Type, should be used. The F-Type mounting method demonstrates reversing thrust load. Combined radial and thrust loads are shown on the B-Type configuration. Both of these methods can be used for heavy radial loads, combined thrust, and radial loads, or moment loads.

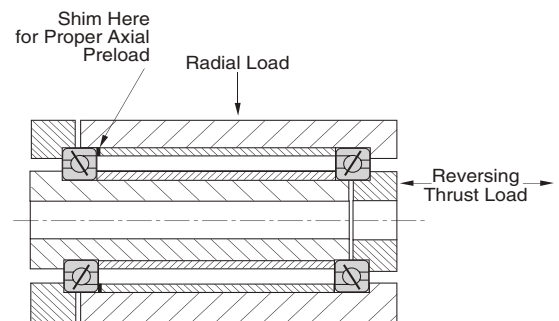

F-Type Configuration

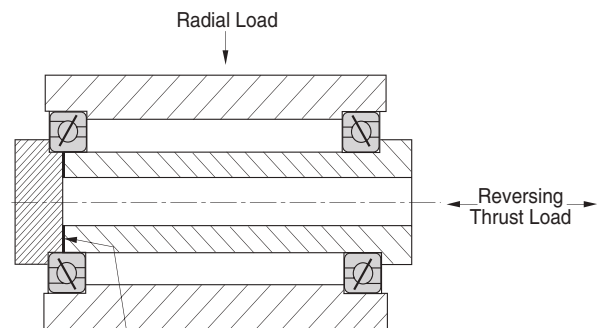

B-Type Configuration

**THIN SECTION
BALL BEARINGS**

Heavy Combined Loading

For heavy combined loading, other special mounting arrangements may be employed. As shown in the top drawing, a duplex pair of A-Type bearings can be used with a floating C-Type bearing. In this configuration, the A-Type bearings will carry the thrust load and part of the radial load while the C-Type carries only radial load. An X-Type bearing can replace the duplex pair of A-Type bearings to carry lower thrust loads as shown in the second drawing.

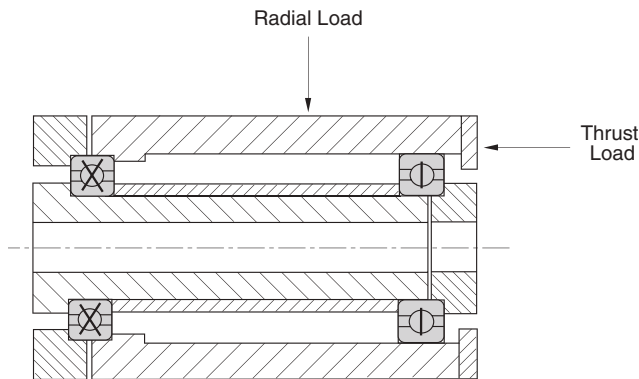
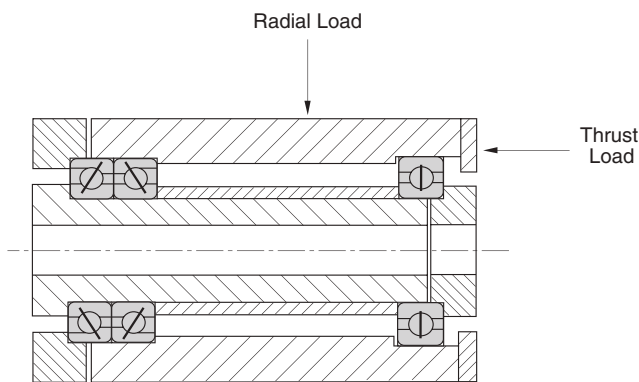

Heavy Combined Loading or Moment Loading

Alternate mountings for heavy combined loading or moment loading are shown below. A duplex pair of B-Type bearings resists high thrust, radial, and moment loads. An X-Type bearing may replace the duplex pair in less heavily loaded applications for weight, space, and cost savings.

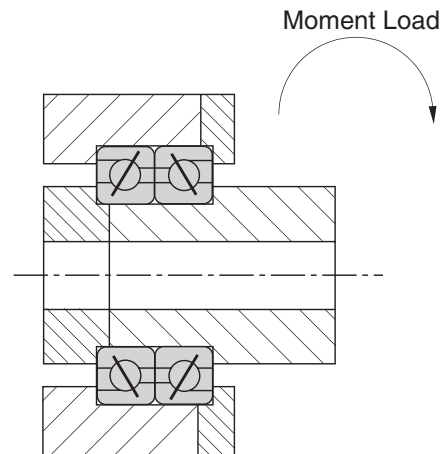

B-Type Configuration

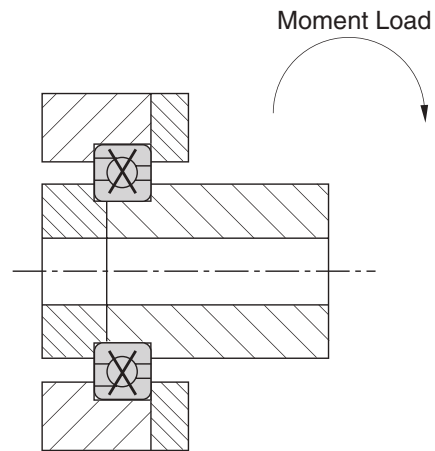

Single Bearing X-Type Configuration

CUSTOM FEATURES

RBC manufactures many custom bearings designed to optimize bearing performance for specific applications. Special features include changes in radial play, lubricants, materials, preloading and design. Contact an RBC Aerospace Bearings sales engineer for your custom bearing needs.

There are many design options available to solve difficult application problems.

Materials

The standard bearings shown in the catalog have SAE 52100 steel rings and balls. RBC thin section ball bearings can be manufactured from other specialty bearing steels to provide corrosion resistance, high temperature capability, alternative load capacity, or chemical compatibility.

Rings— RBC has manufactured thin section ball bearings from SAE CRES 440C to provide corrosion resistance. As an alternative to stainless steel rings, the entire surface of the rings can be plated with nodular thin dense chrome (TDC). This plating, which meets AMS 2438, achieves a molecular bond that will not flake, peel, or separate from the base material. The TDC plate has a hardness of HRC 70-78 and can withstand temperatures well beyond the range of the base material.

Special RBC thin section ball bearings have been manufactured from aluminum, 300 series stainless steel, 17-4PH stainless steel, and other metals.

Balls— Some special ball materials available include 440C CRES, 300 Series stainless steel, silicon nitride, and M-50 steel.

Lubrication

Many different lubricants are available from RBC for special applications. Greases that are designed specifically for high speed, low torque, water resistance, high temperature, oscillatory motion, and food machinery can be provided. Additional lubricants, such as dry film, are suitable for use in vacuums and space applications.

Sealing

Standard seals for thin section ball bearings are molded from elastomers. Polytetra Fluoroethylene (PTFE) seals, fiber glass reinforced PTFE seals, stainless steel shields, and many other options are available for low torque and other special applications.

Radial Play

The radial play (diametral clearance) of a thin section ball bearing will need to be predetermined if mounting fits other than those recommended are used. Special radial play may be required for a temperature differential across the bearing, for housing and shaft materials that have different coefficients of thermal expansion, or to change operating characteristics of the bearing. Radial preloaded bearings are measured to meet bore and O.D. tolerances prior to preload.

Preloading of Duplex Bearings

Standard duplex bearings are ground so that there will be a light axial preload induced on the bearing at nominal conditions. In some applications increased bearing stiffness may be required. In these cases the duplex grinding can be done such that a heavier axial load is induced in the mounted bearing. This load can be increased or decreased to meet the requirements of a particular application. Consult an RBC Aerospace Bearings sales engineer for special requirements.

Mounting Features

Mounting features, such as flanges, anti-rotation tabs, and mounting holes can be incorporated on the inner and outer rings. Mating parts, such as gears and housings, may be integrated into the bearing rings for improved performance and cost.

ELASTOMER MOLDED SEALS VS. PTFE/SS300 SEALS

Typical elastomer molded design

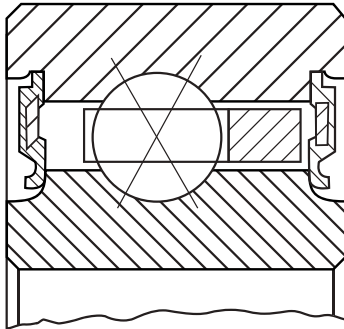

Typical PTFE/SS300 design

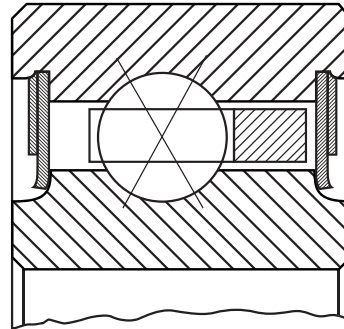

Many molded seals used in bearings are made out of nitrile (molded rubber per MIL-R-6855). The material has a relatively high coefficient of friction. In order to meet low torque bearing requirements, seal fit-up during installation must be adjusted to minimize contact pressure on the sealing surfaces — reducing torque by reducing sealing effectiveness. The inherent variability in the seal molding process can further aggravate these issues. Over time, torque fluctuations are nearly inevitable since seals may reset or the amount of lube between the seal and the sealing surface may change. Based on these performance characteristics, molded seals are often marginal and unreliable solutions for torque sensitive applications.

RBC's solution is a combination seal-shield design. The seal is made from either pure PTFE or glass fiber reinforced PTFE. PTFE is chemically inert, has a very low coefficient of friction (inherent lubricity), and provides the widest operating temperature range of any sealing material. The seal is held in place and shielded with a stainless steel (300 series) flat ring. The seal drag torque in this design is minimal, predictable, and consistent over time.

RBC invariably recommends this design for all low torque or torque sensitive applications that require sealing. RBC can readily retrofit problematic molded seal designs with a PTFE/300SS optimized solution.

Temperature Ranges for Lubrications

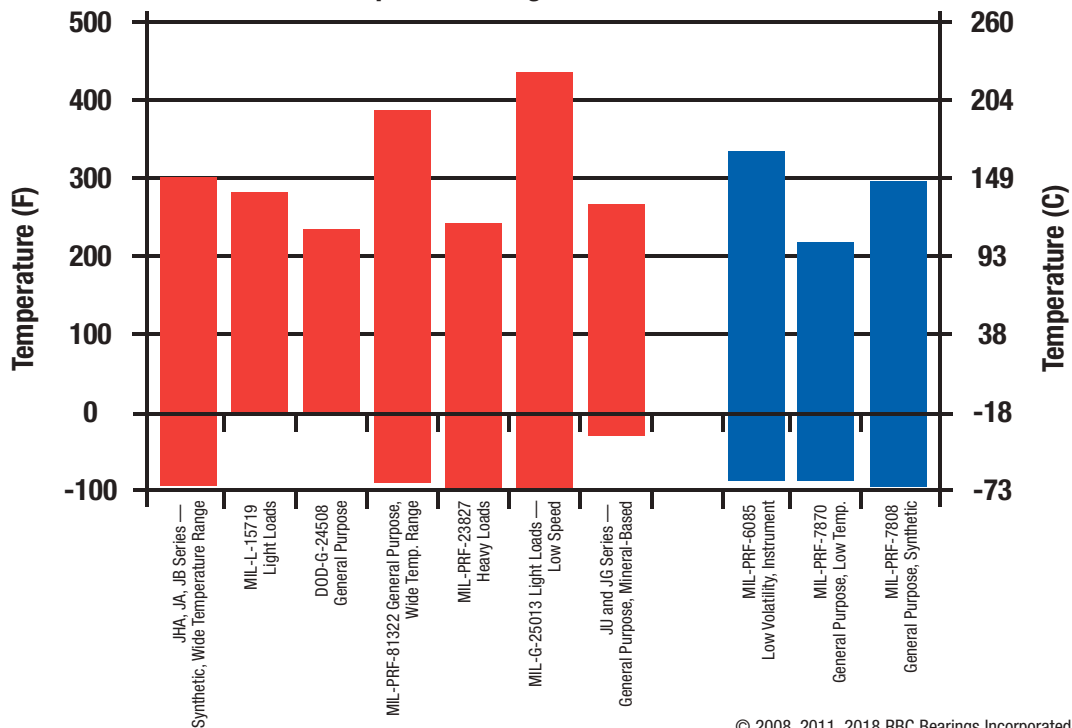

© 2008, 2011, 2018 RBC Bearings Incorporated. All rights reserved.

THIN SECTION BALL BEARINGS

Separators

Standard RBC thin section ball bearings, KA through KG and JU series, are manufactured with brass or nylon separators. The KAA series contains nylon separators. The A-Type bearings contain one-piece circular pocket separators, while the C and X-Types have snap-over separators. The four basic separator materials are brass, nylon, phenolic, and stainless steel.

The graph below schematically illustrates the effects of cage design and material on bearing performance. For example, the one-piece circular pocket design may reach roughly two times the speed of the snap-over design. Likewise, a brass separator design will generate more torque and withstand higher temperatures than a

phenolic separator. Exact speed limits depend on bearing size, bearing type, lubrication and loading. Specific material advantages and limitations are illustrated below. For assistance in selecting the appropriate separator for special applications, contact an RBC Aerospace Bearings sales engineer.



Schematic Illustration of Effects of Cage Design and Material on Bearing Torque, Speed and Temperature.

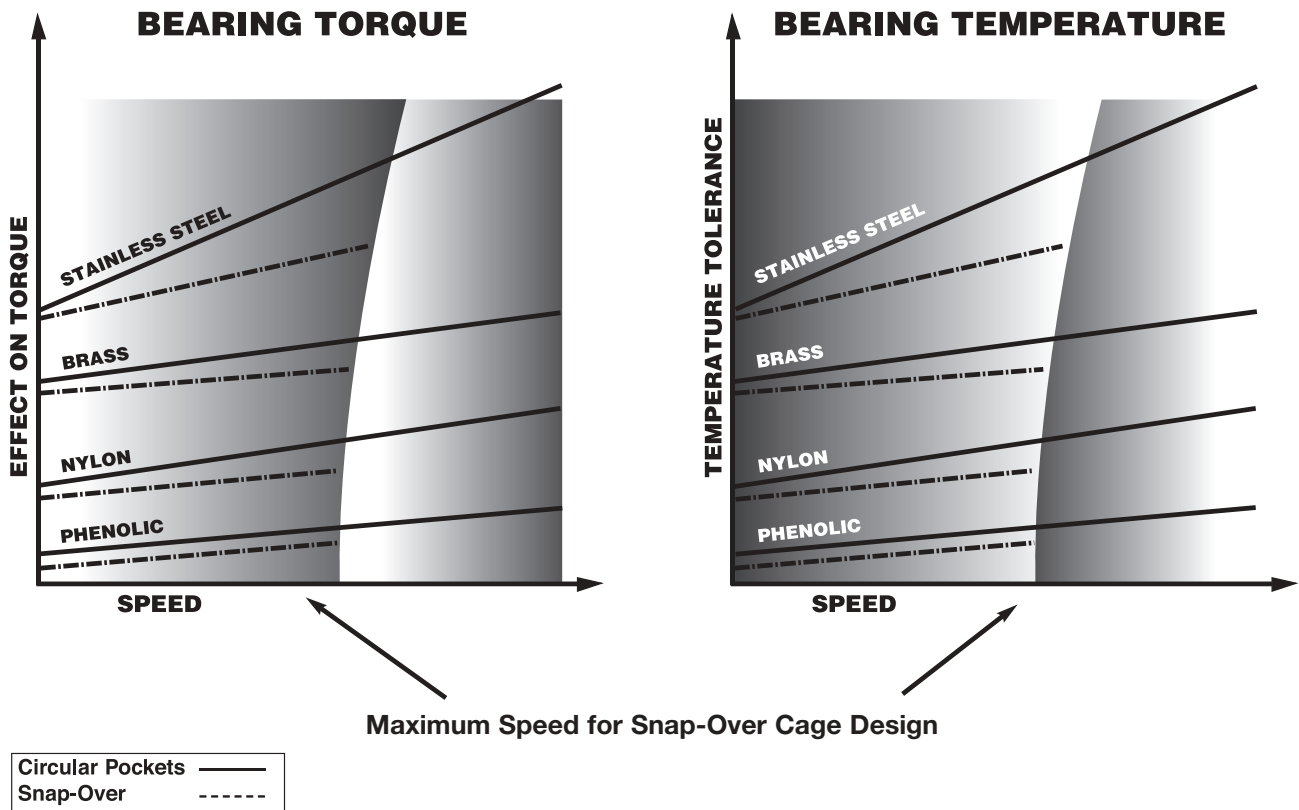

THIN SECTION
BALL BEARINGS

TOLERANCE TABLES AND RECOMMENDED FITS

Precision Tolerances

The RBC thin section ball bearings shown in this catalog are manufactured to ABEC 1F precision tolerances. Where required, RBC thin section ball bearings can be manufactured to ABEC 3F, ABEC 5F, and ABEC 7F precision tolerances.

RBC PRECISION CLASS 0 ABEC 1F C-TYPE

Values in 0.0001 in.

Bearing Bore Size Inches	Diameters		Race Runout Radial & Axial		Width Nominal	Radial Play Before Installation		Rotating Shaft		Stationary Shaft			
	Bore Nominal	O.D. Nominal	Inner Max	Outer Max		Min	Max	Shaft OD Nominal	Housing ID Nominal	Shaft OD Max	Shaft OD Min	Housing ID Max	Housing ID Min
1.00	-4	-5	5	8	-50	10	16	+4	+5	-4	-8	-5	-10
1.50	-5	-5	6	8	-50	12	18	+5	+5	-5	-10	-5	-10
2.00	-6	-5	8	10	-50	12	24	+6	+5	-6	-12	-5	-10
2.50	-6	-5	8	10	-50	12	24	+6	+5	-6	-12	-5	-10
3.00	-6	-6	8	10	-50	12	24	+6	+6	-6	-12	-6	-12
3.50	-8	-6	10	12	-50	16	28	+8	+6	-8	-16	-6	-12
4.00	-8	-6	10	12	-50	16	28	+8	+6	-8	-16	-6	-12
4.25	-8	-8	10	14	-50	16	28	+8	+8	-8	-16	-8	-16
4.50	-8	-8	10	14	-50	16	28	+8	+8	-8	-16	-8	-16
4.75	-10	-8	12	14	-50	20	34	+10	+8	-10	-20	-8	-16
5.00	-10	-8	12	14	-50	20	34	+10	+8	-10	-20	-8	-16
5.50	-10	-10	12	16	-50	20	34	+10	+10	-10	-20	-10	-20
6.00	-10	-10	12	16	-50	20	34	+10	+10	-10	-20	-10	-20
6.50	-10	-10	12	16	-50	20	34	+10	+10	-10	-20	-10	-20
7.00	-10	-10	12	16	-50	20	34	+10	+10	-10	-20	-10	-20
7.50	-12	-12	16	18	-50	24	42	+12	+12	-12	-24	-12	-24
8.00	-12	-12	16	18	-50	24	42	+12	+12	-12	-24	-12	-24
9.00	-12	-12	16	18	-50	24	42	+12	+12	-12	-24	-12	-24
10.00	-14	-14	18	20	-50	28	48	+14	+14	-14	-28	-14	-28
11.00	-14	-14	18	20	-50	28	48	+14	+14	-14	-28	-14	-28
12.00	-14	-14	18	20	-50	28	48	+14	+14	-14	-28	-14	-28
14.00	-16	-16	18	20	-100	32	52	+16	+16	-16	-32	-16	-32
16.00	-18	-18	18	20	-100	36	56	+18	+18	-18	-36	-18	-36
18.00	-18	-18	20	20	-100	36	56	+18	+18	-18	-36	-18	-36
20.00	-20	-20	20	20	-100	40	60	+20	+20	-20	-40	-20	-40
25.00	-30	-30	20	20	-100	60	80	+30	+30	-30	-60	-30	-60
30.00	-30	-30	20	20	-100	60	80	+30	+30	-30	-60	-30	-60
35.00	-40	-40	20	20	-100	80	100	+40	+40	-40	-80	-40	-80
40.00	-40	-40	20	20	-100	80	100	+40	+40	-40	-80	-40	-80

Does not apply to bearings with preload.

DUPLEX PAIR WIDTH TOLERANCES

Values in 0.0001 in.

Bearing Bore Size (Inches)		Width	
Over	Including	Max	Min
-	2.00	0	-200
2.00	5.00	0	-300
5.00	14.00	0	-400
14.00	40.00	0	-500



THIN SECTION BALL BEARINGS

TOLERANCE TABLES AND RECOMMENDED FITS

RBC PRECISION CLASS 0

Values in 0.0001 in.

ABEC 1F A-TYPE AND X-TYPE

Bearing Bore Size Inches	Diameters		Race Runout Radial & Axial		Width Nominal	Radial Play Before Installation*		Rotating Shaft		Stationary Shaft			
	Bore Nominal	O.D. Nominal	Inner Max	Outer Max		Min	Max	Shaft OD Nominal	Housing ID Nominal	Shaft OD		Housing ID	
										Max	Min	Max	Min
1.00	-4	-5	3	4	-50	10	15	+4	+5	-4	-8	-5	-10
1.50	-5	-5	4	4	-50	12	17	+5	+5	-5	-10	-5	-10
2.00	-6	-5	5	5	-50	12	22	+6	+5	-6	-12	-5	-10
2.50	-6	-5	5	5	-50	12	22	+6	+5	-6	-12	-5	-10
3.00	-6	-6	6	6	-50	12	22	+6	+6	-6	-12	-6	-12
3.50	-8	-6	6	6	-50	16	26	+8	+6	-8	-16	-6	-12
4.00	-8	-6	6	6	-50	16	26	+8	+6	-8	-16	-6	-12
4.25	-8	-8	6	8	-50	16	26	+8	+8	-8	-16	-8	-16
4.50	-8	-8	6	8	-50	16	26	+8	+8	-8	-16	-8	-16
4.75	-10	-8	8	8	-50	20	30	+10	+8	-10	-20	-8	-16
5.00	-10	-8	8	8	-50	20	30	+10	+8	-10	-20	-8	-16
5.50	-10	-10	10	10	-50	20	30	+10	+10	-10	-20	-10	-20
6.00	-10	-10	10	10	-50	20	30	+10	+10	-10	-20	-10	-20
6.50	-10	-10	10	10	-50	20	30	+10	+10	-10	-20	-10	-20
7.00	-10	-12	10	10	-50	20	30	+10	+12	-10	-20	-12	-24
7.50	-12	-12	12	12	-50	24	34	+12	+12	-12	-24	-12	-24
8.00	-12	-12	12	12	-50	24	34	+12	+12	-12	-24	-12	-24
9.00	-12	-12	12	12	-50	24	34	+12	+12	-12	-24	-12	-24
10.00	-14	-14	14	14	-50	28	38	+14	+14	-14	-28	-14	-28
11.00	-14	-14	14	14	-50	28	38	+14	+14	-14	-28	-14	-28
12.00	-14	-14	14	14	-50	28	38	+14	+14	-14	-28	-14	-28
14.00	-14	-14	14	14	-100	28	38	+14	+14	-14	-28	-14	-28
16.00	-16	-16	16	16	-100	32	42	+16	+16	-16	-32	-16	-32
18.00	-16	-16	16	16	-100	32	42	+16	+16	-16	-32	-16	-32
20.00	-18	-18	18	18	-100	36	46	+18	+18	-18	-36	-18	-36
25.00	-18	-18	18	18	-100	36	46	+18	+18	-18	-36	-18	-36
30.00	-18	-18	18	18	-100	36	46	+18	+18	-18	-36	-18	-36
35.00	-20	-20	20	20	-100	40	50	+20	+20	-20	-40	-20	-40
40.00	-20	-20	20	20	-100	40	50	+20	+20	-20	-40	-20	-40

Does not apply to bearings with preload.

*X-Type Only

RBC PRECISION CLASS 3

Values in 0.0001 in.

ABEC 3F ALL TYPES

Bearing Bore Size Inches	Diameters		Race Runout Radial & Axial		Width Nominal	Radial Play Before Installation†		Rotating Shaft		Stationary Shaft			
	Bore Nominal	O.D. Nominal	Inner Max	Outer Max		Min	Max	Shaft OD Nominal	Housing ID Nominal	Shaft OD		Housing ID	
										Max	Min	Max	Min
1.00	-2	-3	3	4	-50	7	11	+2	+3	-2	-4	-3	-6
1.50	-3	-3	4	4	-50	8	12	+3	+3	-3	-6	-3	-6
2.00	-4	-4	4	5	-50	8	18	+4	+4	-4	-8	-4	-8
2.50	-4	-4	4	5	-50	8	18	+4	+4	-4	-8	-4	-8
3.00	-4	-4	4	6	-50	8	18	+4	+4	-4	-8	-4	-8
3.50	-5	-4	5	6	-50	10	20	+5	+4	-5	-10	-4	-8
4.00	-5	-4	5	6	-50	10	20	+5	+4	-5	-10	-4	-8
4.25	-5	-5	5	8	-50	10	20	+5	+5	-5	-10	-5	-10
4.50	-5	-5	5	8	-50	10	20	+5	+5	-5	-10	-5	-10
4.75	-6	-5	6	8	-50	12	22	+6	+5	-6	-12	-5	-10
5.00	-6	-5	6	8	-50	12	22	+6	+5	-6	-12	-5	-10
5.50	-6	-6	6	9	-50	12	22	+6	+6	-6	-12	-6	-12
6.00	-6	-6	6	9	-50	12	22	+6	+6	-6	-12	-6	-12
6.50	-6	-6	6	9	-50	12	22	+6	+6	-6	-12	-6	-12
7.00	-6	-7	6	10	-50	14	24	+6	+7	-6	-12	-7	-14
7.50	-7	-7	8	10	-50	14	24	+7	+7	-7	-14	-7	-14
8.00	-7	-7	8	10	-50	14	24	+7	+7	-7	-14	-7	-14
9.00	-7	-7	8	10	-50	14	24	+7	+7	-7	-14	-7	-14
10.00	-8	-8	10	12	-50	16	26	+8	+8	-8	-16	-8	-16
11.00	-8	-8	10	12	-50	16	26	+8	+8	-8	-16	-8	-16
12.00	-8	-9	10	14	-50	18	28	+8	+9	-8	-16	-9	-18
14.00	-8	-9	12	14	-100	18	28	+8	+9	-8	-16	-9	-18
16.00	-9	-10	14	16	-100	20	30	+9	+10	-9	-18	-10	-20
18.00	-9	-10	14	16	-100	20	30	+9	+10	-9	-18	-10	-20
20.00	-10	-12	16	18	-100	24	34	+10	+12	-10	-20	-12	-24

Does not apply to bearings with preload.

†C and X-Type Only

© 2008, 2011, 2018 RBC Bearings Incorporated. All rights reserved.

THIN SECTION BALL BEARINGS

TOLERANCE TABLES AND RECOMMENDED FITS

**RBC PRECISION CLASS 4
ABEC 5F ALL TYPES**

Values in 0.0001 in.

Bearing Bore Size Inches	Diameters		Race Runout				Width Nominal	Radial Play Before Installation [†]		Rotating Shaft		Stationary Shaft			
	Bore Nominal	O.D. Nominal	Radial		Axial			Min	Max	Shaft OD Nominal	Housing ID Nominal	Shaft OD Max	Shaft OD Min	Housing ID Max	Housing ID Min
			Inner Max	Outer Max	Inner Max	Outer Max									
1.00	-2	-2	2	2	3	3	-50	5	9	+2	+2	-2	-4	-2	-4
1.50	-2	-2	2	2	3	3	-50	5	9	+2	+2	-2	-4	-2	-4
2.00	-3	-3	2	3	3	4	-50	5	9	+3	+3	-3	-6	-3	-6
2.50	-3	-3	2	3	3	4	-50	5	9	+3	+3	-3	-6	-3	-6
3.00	-3	-3	2	4	3	5	-50	6	12	+3	+3	-3	-6	-3	-6
3.50	-3	-3	3	4	4	5	-50	6	12	+3	+3	-3	-6	-3	-6
4.00	-3	-3	3	4	4	5	-50	6	12	+3	+3	-3	-6	-3	-6
4.25	-3	-4	3	4	4	5	-50	8	14	+3	+4	-3	-6	-4	-8
4.50	-3	-4	3	4	4	5	-50	8	14	+3	+4	-3	-6	-4	-8
4.75	-4	-4	3	4	4	5	-50	8	14	+4	+4	-4	-8	-4	-8
5.00	-4	-4	3	4	4	5	-50	8	14	+4	+4	-4	-8	-4	-8
5.50	-4	-5	3	5	4	6	-50	10	16	+4	+5	-4	-8	-5	-10
6.00	-4	-5	3	5	4	6	-50	10	16	+4	+5	-4	-8	-5	-10
6.50	-4	-5	3	5	4	6	-50	10	16	+4	+5	-4	-8	-5	-10
7.00	-4	-5	3	5	4	6	-50	10	16	+4	+5	-4	-8	-5	-10
7.50	-5	-5	4	5	5	6	-50	10	16	+5	+5	-5	-10	-5	-10
8.00	-5	-5	4	5	5	6	-50	10	16	+5	+5	-5	-10	-5	-10
9.00	-5	-5	4	5	5	6	-50	10	16	+5	+5	-5	-10	-5	-10
10.00	-5	-5	5	6	6	7	-50	10	16	+5	+5	-5	-10	-5	-10
11.00	-5	-5	5	6	6	7	-50	10	16	+5	+5	-5	-10	-5	-10
12.00	-5	-6	5	7	6	8	-50	12	18	+5	+6	-5	-10	-6	-12
14.00	-6	-6	5	7	7	8	-100	12	18	+6	+6	-6	-12	-6	-12
16.00	-6	-7	7	8	8	9	-100	14	20	+6	+7	-6	-12	-7	-14
18.00	-6	-7	7	8	8	9	-100	14	20	+6	+7	-6	-12	-7	-14
20.00	-7	-8	8	9	9	10	-100	14	22	+7	+8	-7	-14	-8	-16

Does not apply to bearings with preload.

[†]C and X-Type Only

**RBC PRECISION CLASS 6
ABEC 7F ALL TYPES**

Values in 0.0001 in.

Bearing Bore Size Inches	Diameters		Race Runout Radial & Axial		Width Nominal	Radial Play Before Installation [†]		Rotating Shaft		Stationary Shaft			
	Bore Nominal	O.D. Nominal	Inner Max	Outer Max		Min	Max	Shaft OD Nominal	Housing ID Nominal	Shaft OD Max	Shaft OD Min	Housing ID Max	Housing ID Min
1.50	-2	-2	1.5	2	-50	5	9	+2	+2	-2	-4	-2	-4
2.00	-2	-2	1.5	2	-50	5	10	+2	+2	-2	-4	-2	-4
2.50	-2	-2	1.5	2	-50	5	10	+2	+2	-2	-4	-2	-4
3.00	-2	-3	1.5	2	-50	6	12	+2	+3	-2	-4	-3	-6
3.50	-2.5	-3	2	2	-50	6	12	+3	+3	-3	-5	-3	-6
4.00	-2.5	-3	2	2	-50	6	12	+3	+3	-3	-5	-3	-6
4.25	-2.5	-4	2	3	-50	8	14	+3	+4	-3	-5	-4	-8
4.50	-2.5	-4	2	3	-50	8	14	+3	+4	-3	-5	-4	-8
4.75	-3	-4	3	3	-50	8	14	+3	+4	-3	-6	-4	-8
5.00	-3	-4	3	3	-50	8	14	+3	+4	-3	-6	-4	-8
5.50	-3	-4	3	3	-50	8	14	+3	+4	-3	-6	-4	-8
6.00	-3	-4	3	3	-50	8	14	+3	+4	-3	-6	-4	-8
6.50	-3	-4	3	3	-50	8	14	+3	+4	-3	-6	-4	-8
7.00	-3	-4	3	4	-50	8	14	+3	+4	-3	-6	-4	-8
7.50	-4	-4	3	4	-50	8	14	+4	+4	-4	-8	-4	-8
8.00	-4	-4	3	4	-50	8	14	+4	+4	-4	-8	-4	-8
9.00	-4	-4	3	4	-50	8	14	+4	+4	-4	-8	-4	-8
10.00	-5	-5	4	4	-50	10	16	+5	+5	-5	-10	-5	-10
11.00	-5	-5	4	4	-50	10	16	+5	+5	-5	-10	-5	-10
12.00	-5	-5	4	5	-50	10	16	+5	+5	-5	-10	-5	-10
14.00	-5	-6	4	5	-100	12	18	+5	+6	-5	-10	-6	-12

Does not apply to bearings with preload.

[†]C and X-Type Only

THIN SECTION BALL BEARINGS

THIN SECTION BALL BEARINGS TABLES



THIN SECTION BALL BEARINGS — RADIAL CONTACT, C-TYPE



RADIAL CONTACT, C-TYPE

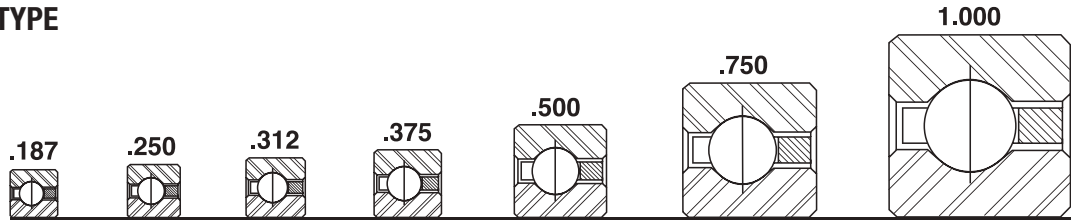

Series:	KAA	KA	KB	KC	KD	KF	KG
Cross Section Size:	3/16"	1/4"	5/16"	3/8"	1/2"	3/4"	1"

PART NUMBER*	NOMINAL DIMENSIONS												
	B Bore		D Outside Diameter		W Width		Land Diameter		f ₁ Housing Fillet		Ball Diameter		
	in.	mm	in.	mm	in.	mm	L _i -Inner Ring	L _o -Outer Ring	in.	mm			
KAA10CLO*RBC	1.0000	25.400	1.3750	34.925	0.1875	4.763	1.141	28.98	1.234	31.34	0.015	0.38	3/32
KAA15CLO*RBC	1.5000	38.100	1.8750	47.625	0.1875	4.763	1.641	41.68	1.734	44.04	0.015	0.38	3/32
KA020CP0*RBC	2.0000	50.800	2.5000	63.500	0.2500	6.350	2.188	55.58	2.313	58.75	0.025	0.64	1/8
KB020CP0*RBC	2.0000	50.800	2.6250	66.675	0.3125	7.938	2.234	56.74	2.391	60.73	0.032	0.81	5/32
KA025CP0*RBC	2.5000	63.500	3.0000	76.200	0.2500	6.350	2.688	68.28	2.813	71.45	0.025	0.64	1/8
KB025CP0*RBC	2.5000	63.500	3.1250	79.375	0.3125	7.938	2.734	69.44	2.891	73.43	0.032	0.81	5/32
KA030CP0*RBC	3.0000	76.200	3.5000	88.900	0.2500	6.350	3.188	80.98	3.313	84.15	0.025	0.64	1/8
KB030CP0*RBC	3.0000	76.200	3.6250	92.075	0.3125	7.938	3.234	82.14	3.391	86.13	0.032	0.81	5/32
KA035CP0*RBC	3.5000	88.900	4.0000	101.600	0.2500	6.350	3.688	93.68	3.813	96.85	0.025	0.64	1/8
KB035CP0*RBC	3.5000	88.900	4.1250	104.775	0.3125	7.938	3.734	94.84	3.897	98.98	0.032	0.81	5/32
KA040CP0*RBC	4.0000	101.600	4.5000	114.300	0.2500	6.350	4.188	106.38	4.313	109.55	0.025	0.64	1/8
KB040CP0*RBC	4.0000	101.600	4.6250	117.475	0.3125	7.938	4.234	107.54	4.391	111.53	0.032	0.81	5/32
KC040CP0*RBC	4.0000	101.600	4.7500	120.650	0.3750	9.525	4.281	108.74	4.469	113.51	0.040	1.02	3/16
KD040CP0*RBC	4.0000	101.600	5.0000	127.000	0.5000	12.700	4.375	111.13	4.625	117.48	0.060	1.52	1/4
KF040CP0*RBC	4.0000	101.600	5.5000	139.700	0.7500	19.050	4.563	115.90	4.938	125.43	0.080	2.03	3/8
KG040CP0*RBC	4.0000	101.600	6.0000	152.400	1.0000	25.400	4.750	120.65	5.250	133.35	0.080	2.03	1/2
KA042CP0*RBC	4.2500	107.950	4.7500	120.650	0.2500	6.350	4.438	112.73	4.563	115.90	0.025	0.64	1/8
KB042CP0*RBC	4.2500	107.950	4.8750	123.825	0.3125	7.938	4.484	113.89	4.641	117.88	0.032	0.81	5/32
KC042CP0*RBC	4.2500	107.950	5.0000	127.000	0.3750	9.525	4.531	115.09	4.719	119.86	0.040	1.02	3/16
KD042CP0*RBC	4.2500	107.950	5.2500	133.350	0.5000	12.700	4.625	117.48	4.875	123.83	0.060	1.52	1/4
KF042CP0*RBC	4.2500	107.950	5.7500	146.050	0.7500	19.050	4.813	122.25	5.188	131.78	0.080	2.03	3/8
KG042CP0*RBC	4.2500	107.950	6.2500	158.750	1.0000	25.400	5.000	127.00	5.500	139.70	0.080	2.03	1/2
KA045CP0*RBC	4.5000	114.300	5.0000	127.000	0.2500	6.350	4.688	119.08	4.813	122.25	0.025	0.64	1/8
KB045CP0*RBC	4.5000	114.300	5.1250	130.175	0.3125	7.938	4.734	120.24	4.891	124.23	0.032	0.81	5/32
KC045CP0*RBC	4.5000	114.300	5.2500	133.350	0.3750	9.525	4.781	121.44	4.969	126.21	0.040	1.02	3/16
KD045CP0*RBC	4.5000	114.300	5.5000	139.700	0.5000	12.700	4.875	123.83	5.125	130.18	0.060	1.52	1/4
KF045CP0*RBC	4.5000	114.300	6.0000	152.400	0.7500	19.050	5.063	128.60	5.438	138.13	0.080	2.03	3/8
KG045CP0*RBC	4.5000	114.300	6.5000	165.100	1.0000	25.400	5.250	133.35	5.750	146.05	0.080	2.03	1/2
KA047CP0*RBC	4.7500	120.650	5.2500	133.350	0.2500	6.350	4.938	125.43	5.063	128.60	0.025	0.64	1/8
KB047CP0*RBC	4.7500	120.650	5.3750	136.525	0.3125	7.938	4.984	126.59	5.141	130.58	0.032	0.81	5/32
KC047CP0*RBC	4.7500	120.650	5.5000	139.700	0.3750	9.525	5.031	127.79	5.219	132.56	0.040	1.02	3/16
KD047CP0*RBC	4.7500	120.650	5.7500	146.050	0.5000	12.700	5.125	130.18	5.375	136.53	0.060	1.52	1/4
KF047CP0*RBC	4.7500	120.650	6.2500	158.750	0.7500	19.050	5.313	134.95	5.688	144.48	0.080	2.03	3/8
KG047CP0*RBC	4.7500	120.650	6.7500	171.450	1.0000	25.400	5.500	139.70	6.000	152.40	0.080	2.03	1/2
KA050CP0*RBC	5.0000	127.000	5.5000	139.700	0.2500	6.350	5.188	131.78	5.313	134.95	0.025	0.64	1/8
KB050CP0*RBC	5.0000	127.000	5.6250	142.875	0.3125	7.938	5.234	132.94	5.391	136.93	0.032	0.81	5/32
KC050CP0*RBC	5.0000	127.000	5.7500	146.050	0.3750	9.525	5.281	134.14	5.469	138.91	0.040	1.02	3/16
KD050CP0*RBC	5.0000	127.000	6.0000	152.400	0.5000	12.700	5.375	136.53	5.625	142.88	0.060	1.52	1/4
KF050CP0*RBC	5.0000	127.000	6.5000	165.100	0.7500	19.050	5.563	141.30	5.938	150.83	0.080	2.03	3/8
KG050CP0*RBC	5.0000	127.000	7.0000	177.800	1.0000	25.400	5.750	146.05	6.250	158.75	0.080	2.03	1/2
KA055CP0*RBC	5.5000	139.700	6.0000	152.400	0.2500	6.350	5.688	144.48	5.813	147.65	0.025	0.64	1/8
KB055CP0*RBC	5.5000	139.700	6.1250	155.575	0.3125	7.938	5.734	145.64	5.891	149.63	0.032	0.81	5/32
KC055CP0*RBC	5.5000	139.700	6.2500	158.750	0.3750	9.525	5.781	146.84	5.969	151.61	0.040	1.02	3/16
KD055CP0*RBC	5.5000	139.700	6.5000	165.100	0.5000	12.700	5.875	149.23	6.125	155.58	0.060	1.52	1/4
KF055CP0*RBC	5.5000	139.700	7.0000	177.800	0.7500	19.050	6.063	154.00	6.438	163.53	0.080	2.03	3/8
KG055CP0*RBC	5.5000	139.700	7.5000	190.500	1.0000	25.400	6.250	158.75	6.750	171.45	0.080	2.03	1/2

*The alphanumeric identification system is used under license.

© 2008, 2011, 2018 RBC Bearings Incorporated. All rights reserved.

THIN SECTION BALL BEARINGS



- 52100 steel
- Large diameter
- Light weight
- Small cross-section
- Snap-over ball separator

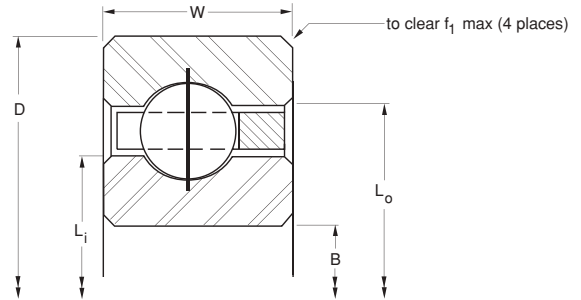

	Ball Quantity	Approx. Weight		LOAD RATINGS									PART NUMBER*			
				Radial		Thrust				Moment						
				Static	Dynamic	Static	Dynamic	Static	Dynamic	Static	Dynamic					
lbs.	kg	lbf	N	lbf	N	lbf	N	lbf - in	Nm	lbf - in	Nm					
	21	0.03	0.014	290	1,290	300	1,330	N/A	N/A	N/A	N/A	N/A	N/A	N/A	N/A	KAA10CLO*RBC
	29	0.04	0.018	400	1,780	350	1,560	N/A	N/A	N/A	N/A	N/A	N/A	N/A	N/A	KAA15CLO*RBC
	27	0.10	0.045	680	3,020	560	2,490	N/A	N/A	N/A	N/A	N/A	N/A	N/A	N/A	KA020CPO*RBC
	23	0.16	0.073	930	4,140	800	3,560	N/A	N/A	N/A	N/A	N/A	N/A	N/A	N/A	KB020CPO*RBC
	33	0.13	0.059	830	3,690	610	2,710	N/A	N/A	N/A	N/A	N/A	N/A	N/A	N/A	KA025CPO*RBC
	28	0.20	0.091	1,140	5,070	860	3,830	N/A	N/A	N/A	N/A	N/A	N/A	N/A	N/A	KB025CPO*RBC
	39	0.15	0.068	990	4,400	650	2,890	N/A	N/A	N/A	N/A	N/A	N/A	N/A	N/A	KA030CPO*RBC
	33	0.24	0.109	1,340	5,960	920	4,090	N/A	N/A	N/A	N/A	N/A	N/A	N/A	N/A	KB030CPO*RBC
	45	0.18	0.082	1,140	5,070	690	3,070	N/A	N/A	N/A	N/A	N/A	N/A	N/A	N/A	KA035CPO*RBC
	38	0.27	0.122	1,540	6,850	970	4,310	N/A	N/A	N/A	N/A	N/A	N/A	N/A	N/A	KB035CPO*RBC
	51	0.19	0.086	1,290	5,740	720	3,200	N/A	N/A	N/A	N/A	N/A	N/A	N/A	N/A	KA040CPO*RBC
	43	0.30	0.136	1,750	7,780	1,020	4,540	N/A	N/A	N/A	N/A	N/A	N/A	N/A	N/A	KB040CPO*RBC
	35	0.45	0.204	2,100	9,340	1,290	5,740	N/A	N/A	N/A	N/A	N/A	N/A	N/A	N/A	KC040CPO*RBC
	27	0.78	0.354	3,080	13,700	2,250	10,010	N/A	N/A	N/A	N/A	N/A	N/A	N/A	N/A	KD040CPO*RBC
	19	1.90	0.862	5,360	23,840	3,940	17,530	N/A	N/A	N/A	N/A	N/A	N/A	N/A	N/A	KF040CPO*RBC
	15	3.60	1.633	8,210	36,520	6,700	29,800	N/A	N/A	N/A	N/A	N/A	N/A	N/A	N/A	KG040CPO*RBC
	54	0.20	0.091	1,370	6,090	730	3,250	N/A	N/A	N/A	N/A	N/A	N/A	N/A	N/A	KA042CPO*RBC
	45	0.31	0.141	1,830	8,140	1,030	4,580	N/A	N/A	N/A	N/A	N/A	N/A	N/A	N/A	KB042CPO*RBC
	37	0.47	0.213	2,220	9,880	1,320	5,870	N/A	N/A	N/A	N/A	N/A	N/A	N/A	N/A	KC042CPO*RBC
	28	0.83	0.376	3,190	14,190	2,270	10,100	N/A	N/A	N/A	N/A	N/A	N/A	N/A	N/A	KD042CPO*RBC
	20	2.00	0.907	5,640	25,090	4,070	18,100	N/A	N/A	N/A	N/A	N/A	N/A	N/A	N/A	KF042CPO*RBC
	15	3.80	1.724	8,210	36,520	6,700	29,800	N/A	N/A	N/A	N/A	N/A	N/A	N/A	N/A	KG042CPO*RBC
	57	0.22	0.100	1,440	6,410	750	3,340	N/A	N/A	N/A	N/A	N/A	N/A	N/A	N/A	KA045CPO*RBC
	48	0.33	0.150	1,950	8,670	1,060	4,720	N/A	N/A	N/A	N/A	N/A	N/A	N/A	N/A	KB045CPO*RBC
	39	0.48	0.218	2,340	10,410	1,350	6,010	N/A	N/A	N/A	N/A	N/A	N/A	N/A	N/A	KC045CPO*RBC
	30	0.88	0.399	3,420	15,210	2,350	10,450	N/A	N/A	N/A	N/A	N/A	N/A	N/A	N/A	KD045CPO*RBC
	21	2.10	0.953	5,930	26,380	4,210	18,730	N/A	N/A	N/A	N/A	N/A	N/A	N/A	N/A	KF045CPO*RBC
	16	4.00	1.814	8,760	38,970	7,000	31,140	N/A	N/A	N/A	N/A	N/A	N/A	N/A	N/A	KG045CPO*RBC
	60	0.23	0.104	1,520	6,760	760	3,380	N/A	N/A	N/A	N/A	N/A	N/A	N/A	N/A	KA047CPO*RBC
	50	0.34	0.154	2,030	9,030	1,070	4,760	N/A	N/A	N/A	N/A	N/A	N/A	N/A	N/A	KB047CPO*RBC
	41	0.50	0.227	2,460	10,940	1,370	6,090	N/A	N/A	N/A	N/A	N/A	N/A	N/A	N/A	KC047CPO*RBC
	31	0.94	0.426	3,530	15,700	2,360	10,500	N/A	N/A	N/A	N/A	N/A	N/A	N/A	N/A	KD047CPO*RBC
	22	2.20	0.998	6,210	27,620	4,310	19,170	N/A	N/A	N/A	N/A	N/A	N/A	N/A	N/A	KF047CPO*RBC
	17	4.10	1.860	9,300	41,370	7,290	32,430	N/A	N/A	N/A	N/A	N/A	N/A	N/A	N/A	KG047CPO*RBC
	63	0.24	0.109	1,590	7,070	770	3,430	N/A	N/A	N/A	N/A	N/A	N/A	N/A	N/A	KA050CPO*RBC
	53	0.38	0.172	2,150	9,560	1,100	4,890	N/A	N/A	N/A	N/A	N/A	N/A	N/A	N/A	KB050CPO*RBC
	43	0.58	0.263	2,590	11,520	1,390	6,180	N/A	N/A	N/A	N/A	N/A	N/A	N/A	N/A	KC050CPO*RBC
	33	1.00	0.454	3,760	16,730	2,430	10,810	N/A	N/A	N/A	N/A	N/A	N/A	N/A	N/A	KD050CPO*RBC
	23	2.30	1.043	6,490	28,870	4,380	19,480	N/A	N/A	N/A	N/A	N/A	N/A	N/A	N/A	KF050CPO*RBC
	18	4.30	1.950	9,850	43,810	7,570	33,670	N/A	N/A	N/A	N/A	N/A	N/A	N/A	N/A	KG050CPO*RBC
	69	0.25	0.113	1,750	7,780	800	3,560	N/A	N/A	N/A	N/A	N/A	N/A	N/A	N/A	KA055CPO*RBC
	58	0.41	0.186	2,360	10,500	1,130	5,030	N/A	N/A	N/A	N/A	N/A	N/A	N/A	N/A	KB055CPO*RBC
	47	0.59	0.268	2,830	12,590	1,440	6,410	N/A	N/A	N/A	N/A	N/A	N/A	N/A	N/A	KC055CPO*RBC
	36	1.06	0.481	4,100	18,240	2,510	11,170	N/A	N/A	N/A	N/A	N/A	N/A	N/A	N/A	KD055CPO*RBC
	25	2.50	1.134	7,050	31,360	4,540	20,190	N/A	N/A	N/A	N/A	N/A	N/A	N/A	N/A	KF055CPO*RBC
	19	4.70	2.132	10,400	46,260	7,850	34,920	N/A	N/A	N/A	N/A	N/A	N/A	N/A	N/A	KG055CPO*RBC

Refer to the Engineering section for load and speed limitations.

© 2008, 2011, 2018 RBC Bearings Incorporated. All rights reserved.

THIN SECTION BALL BEARINGS

THIN SECTION BALL BEARINGS — RADIAL CONTACT, C-TYPE



RADIAL CONTACT, C-TYPE

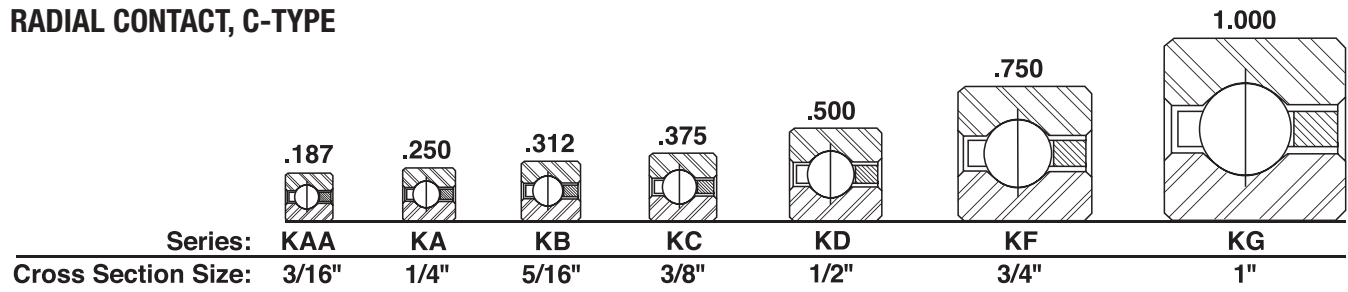

PART NUMBER*	NOMINAL DIMENSIONS												
	B Bore		D Outside Diameter		W Width		Land Diameter				f ₁ Housing Fillet		Ball Diameter
	in.	mm	in.	mm	in.	mm	L _i -Inner Ring		L _o -Outer Ring		in.	mm	in.
KA060CP0*RBC	6.0000	152.400	6.5000	165.100	0.2500	6.350	6.188	157.18	6.313	160.35	0.025	0.64	1/8
KB060CP0*RBC	6.0000	152.400	6.6250	168.275	0.3125	7.938	6.234	158.34	6.391	162.33	0.032	0.81	5/32
KC060CP0*RBC	6.0000	152.400	6.7500	171.450	0.3750	9.525	6.281	159.54	6.469	164.31	0.040	1.02	3/16
KD060CP0*RBC	6.0000	152.400	7.0000	177.800	0.5000	12.700	6.375	161.93	6.625	168.28	0.060	1.52	1/4
KF060CP0*RBC	6.0000	152.400	7.5000	190.500	0.7500	19.050	6.563	166.70	6.938	176.23	0.080	2.03	3/8
KG060CP0*RBC	6.0000	152.400	8.0000	203.200	1.0000	25.400	6.750	171.45	7.250	184.15	0.080	2.03	1/2
KA065CP0*RBC	6.5000	165.100	7.0000	177.800	0.2500	6.350	6.688	169.88	6.813	173.05	0.025	0.64	1/8
KB065CP0*RBC	6.5000	165.100	7.1250	180.975	0.3125	7.938	6.734	171.04	6.891	175.03	0.032	0.81	5/32
KC065CP0*RBC	6.5000	165.100	7.2500	184.150	0.3750	9.525	6.781	172.24	6.969	177.01	0.040	1.02	3/16
KD065CP0*RBC	6.5000	165.100	7.5000	190.500	0.5000	12.700	6.875	174.63	7.125	180.98	0.060	1.52	1/4
KF065CP0*RBC	6.5000	165.100	8.0000	203.200	0.7500	19.050	7.063	179.40	7.438	188.93	0.080	2.03	3/8
KG065CP0*RBC	6.5000	165.100	8.5000	215.900	1.0000	25.400	7.250	184.15	7.750	196.85	0.080	2.03	1/2
KA070CP0*RBC	7.0000	177.800	7.5000	190.500	0.2500	6.350	7.188	182.58	7.313	185.75	0.025	0.64	1/8
KB070CP0*RBC	7.0000	177.800	7.6250	193.675	0.3125	7.938	7.234	183.74	7.391	187.73	0.032	0.81	5/32
KC070CP0*RBC	7.0000	177.800	7.7500	196.850	0.3750	9.525	7.281	184.94	7.469	189.71	0.040	1.02	3/16
KD070CP0*RBC	7.0000	177.800	8.0000	203.200	0.5000	12.700	7.375	187.33	7.625	193.68	0.060	1.52	1/4
KF070CP0*RBC	7.0000	177.800	8.5000	215.900	0.7500	19.050	7.563	192.10	7.938	201.63	0.080	2.03	3/8
KG070CP0*RBC	7.0000	177.800	9.0000	228.600	1.0000	25.400	7.750	196.85	8.250	209.55	0.080	2.03	1/2
KA075CP0*RBC	7.5000	190.500	8.0000	203.200	0.2500	6.350	7.688	195.28	7.813	198.45	0.025	0.64	1/8
KB075CP0*RBC	7.5000	190.500	8.1250	206.375	0.3125	7.938	7.734	196.44	7.891	200.43	0.032	0.81	5/32
KC075CP0*RBC	7.5000	190.500	8.2500	209.550	0.3750	9.525	7.781	197.64	7.969	202.41	0.040	1.02	3/16
KD075CP0*RBC	7.5000	190.500	8.5000	215.900	0.5000	12.700	7.875	200.03	8.125	206.38	0.060	1.52	1/4
KF075CP0*RBC	7.5000	190.500	9.0000	228.600	0.7500	19.050	8.063	204.80	8.438	214.33	0.080	2.03	3/8
KG075CP0*RBC	7.5000	190.500	9.5000	241.300	1.0000	25.400	8.250	209.55	8.750	222.25	0.080	2.03	1/2
KA080CP0*RBC	8.0000	203.200	8.5000	215.900	0.2500	6.350	8.188	207.98	8.313	211.15	0.025	0.64	1/8
KB080CP0*RBC	8.0000	203.200	8.6250	219.075	0.3125	7.938	8.234	209.14	8.391	213.13	0.032	0.81	5/32
KC080CP0*RBC	8.0000	203.200	8.7500	222.250	0.3750	9.525	8.281	210.34	8.469	215.11	0.040	1.02	3/16
KD080CP0*RBC	8.0000	203.200	9.0000	228.600	0.5000	12.700	8.375	212.73	8.625	219.08	0.060	1.52	1/4
KF080CP0*RBC	8.0000	203.200	9.5000	241.300	0.7500	19.050	8.563	217.50	8.938	227.03	0.080	2.03	3/8
KG080CP0*RBC	8.0000	203.200	10.0000	254.000	1.0000	25.400	8.750	222.25	9.250	234.95	0.080	2.03	1/2
KA090CP0*RBC	9.0000	228.600	9.5000	241.300	0.2500	6.350	9.188	233.38	9.313	236.55	0.025	0.64	1/8
KB090CP0*RBC	9.0000	228.600	9.6250	244.475	0.3125	7.938	9.234	234.54	9.391	238.53	0.032	0.81	5/32
KC090CP0*RBC	9.0000	228.600	9.7500	247.650	0.3750	9.525	9.281	235.74	9.469	240.51	0.040	1.02	3/16
KD090CP0*RBC	9.0000	228.600	10.0000	254.000	0.5000	12.700	9.375	238.13	9.625	244.48	0.060	1.52	1/4
KF090CP0*RBC	9.0000	228.600	10.5000	266.700	0.7500	19.050	9.563	242.90	9.938	252.43	0.080	2.03	3/8
KG090CP0*RBC	9.0000	228.600	11.0000	279.400	1.0000	25.400	9.750	247.65	10.250	260.35	0.080	2.03	1/2
KA100CP0*RBC	10.0000	254.000	10.5000	266.700	0.2500	6.350	10.188	258.78	10.313	261.95	0.025	0.64	1/8
KB100CP0*RBC	10.0000	254.000	10.6250	269.875	0.3125	7.938	10.234	259.94	10.391	263.93	0.032	0.81	5/32
KC100CP0*RBC	10.0000	254.000	10.7500	273.050	0.3750	9.525	10.281	261.14	10.469	265.91	0.040	1.02	3/16
KD100CP0*RBC	10.0000	254.000	11.0000	279.400	0.5000	12.700	10.375	263.53	10.625	269.88	0.060	1.52	1/4
KF100CP0*RBC	10.0000	254.000	11.5000	292.100	0.7500	19.050	10.563	268.30	10.938	277.83	0.080	2.03	3/8
KG100CP0*RBC	10.0000	254.000	12.0000	304.800	1.0000	25.400	10.750	273.05	11.250	285.75	0.080	2.03	1/2

© 2008, 2011, 2018 RBC Bearings Incorporated. All rights reserved.

THIN SECTION BALL BEARINGS



- 52100 steel
- Large diameter
- Light weight
- Small cross-section
- Snap-over ball separator

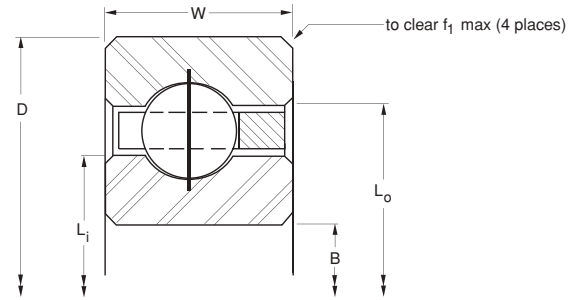

	Ball Quantity	Approx. Weight		LOAD RATINGS										PART NUMBER*		
				Radial				Thrust				Moment				
				Static		Dynamic		Static		Dynamic		Static			Dynamic	
lbs.	kg	lbf	N	lbf	N	lbf	N	lbf	N	lbf - in	Nm	lbf - in	Nm			
	75	0.28	0.127	1,900	8,450	830	3,690	N/A	N/A	N/A	N/A	N/A	N/A	N/A	N/A	KA060CP0*RBC
	63	0.44	0.200	2,560	11,390	1,170	5,200	N/A	N/A	N/A	N/A	N/A	N/A	N/A	N/A	KB060CP0*RBC
	51	0.63	0.286	3,070	13,660	1,490	6,630	N/A	N/A	N/A	N/A	N/A	N/A	N/A	N/A	KC060CP0*RBC
	39	1.16	0.526	4,450	19,790	2,580	11,480	N/A	N/A	N/A	N/A	N/A	N/A	N/A	N/A	KD060CP0*RBC
	27	2.70	1.225	7,620	33,900	4,660	20,730	N/A	N/A	N/A	N/A	N/A	N/A	N/A	N/A	KF060CP0*RBC
	21	5.10	2.313	11,490	51,110	8,390	37,320	N/A	N/A	N/A	N/A	N/A	N/A	N/A	N/A	KG060CP0*RBC
	81	0.30	0.136	2,050	9,120	850	3,780	N/A	N/A	N/A	N/A	N/A	N/A	N/A	N/A	KA065CP0*RBC
	68	0.47	0.213	2,760	12,280	1,200	5,340	N/A	N/A	N/A	N/A	N/A	N/A	N/A	N/A	KB065CP0*RBC
	55	0.68	0.308	3,310	14,720	1,530	6,810	N/A	N/A	N/A	N/A	N/A	N/A	N/A	N/A	KC065CP0*RBC
	42	1.22	0.553	4,790	21,310	2,650	11,790	N/A	N/A	N/A	N/A	N/A	N/A	N/A	N/A	KD065CP0*RBC
	29	2.90	1.315	8,180	36,390	4,790	21,310	N/A	N/A	N/A	N/A	N/A	N/A	N/A	N/A	KF065CP0*RBC
	22	5.40	2.449	12,040	53,560	8,520	37,900	N/A	N/A	N/A	N/A	N/A	N/A	N/A	N/A	KG065CP0*RBC
	87	0.31	0.141	2,200	9,790	870	3,870	N/A	N/A	N/A	N/A	N/A	N/A	N/A	N/A	KA070CP0*RBC
	73	0.50	0.227	2,970	13,210	1,240	5,520	N/A	N/A	N/A	N/A	N/A	N/A	N/A	N/A	KB070CP0*RBC
	59	0.73	0.331	3,550	15,790	1,570	6,980	N/A	N/A	N/A	N/A	N/A	N/A	N/A	N/A	KC070CP0*RBC
	45	1.31	0.594	5,130	22,820	2,730	12,140	N/A	N/A	N/A	N/A	N/A	N/A	N/A	N/A	KD070CP0*RBC
	31	3.20	1.451	8,750	38,920	4,920	21,890	N/A	N/A	N/A	N/A	N/A	N/A	N/A	N/A	KF070CP0*RBC
	24	5.80	2.631	13,130	58,410	8,880	39,500	N/A	N/A	N/A	N/A	N/A	N/A	N/A	N/A	KG070CP0*RBC
	93	0.34	0.154	2,350	10,450	890	3,960	N/A	N/A	N/A	N/A	N/A	N/A	N/A	N/A	KA075CP0*RBC
	78	0.53	0.240	3,170	14,100	1,280	5,690	N/A	N/A	N/A	N/A	N/A	N/A	N/A	N/A	KB075CP0*RBC
	63	0.78	0.354	3,790	16,860	1,600	7,120	N/A	N/A	N/A	N/A	N/A	N/A	N/A	N/A	KC075CP0*RBC
	48	1.41	0.640	5,470	24,330	2,800	12,460	N/A	N/A	N/A	N/A	N/A	N/A	N/A	N/A	KD075CP0*RBC
	33	3.40	1.542	9,310	41,410	5,040	22,420	N/A	N/A	N/A	N/A	N/A	N/A	N/A	N/A	KF075CP0*RBC
	25	6.10	2.767	10,640	47,330	8,960	39,860	N/A	N/A	N/A	N/A	N/A	N/A	N/A	N/A	KG075CP0*RBC
	99	0.38	0.172	2,500	11,120	910	4,050	N/A	N/A	N/A	N/A	N/A	N/A	N/A	N/A	KA080CP0*RBC
	83	0.57	0.259	3,370	14,990	1,280	5,690	N/A	N/A	N/A	N/A	N/A	N/A	N/A	N/A	KB080CP0*RBC
	67	0.84	0.381	4,030	17,930	1,650	7,340	N/A	N/A	N/A	N/A	N/A	N/A	N/A	N/A	KC080CP0*RBC
	51	1.53	0.694	5,810	25,840	2,860	12,720	N/A	N/A	N/A	N/A	N/A	N/A	N/A	N/A	KD080CP0*RBC
	35	3.50	1.588	9,880	43,950	5,140	22,860	N/A	N/A	N/A	N/A	N/A	N/A	N/A	N/A	KF080CP0*RBC
	27	6.50	2.948	14,770	65,700	9,300	41,370	N/A	N/A	N/A	N/A	N/A	N/A	N/A	N/A	KG080CP0*RBC
	111	0.44	0.200	2,810	12,500	940	4,180	N/A	N/A	N/A	N/A	N/A	N/A	N/A	N/A	KA090CP0*RBC
	93	0.66	0.299	3,780	16,810	1,330	5,920	N/A	N/A	N/A	N/A	N/A	N/A	N/A	N/A	KB090CP0*RBC
	75	0.94	0.426	4,510	20,060	1,730	7,700	N/A	N/A	N/A	N/A	N/A	N/A	N/A	N/A	KC090CP0*RBC
	57	1.72	0.780	6,500	28,910	2,970	13,210	N/A	N/A	N/A	N/A	N/A	N/A	N/A	N/A	KD090CP0*RBC
	39	3.90	1.769	11,000	48,930	5,360	23,840	N/A	N/A	N/A	N/A	N/A	N/A	N/A	N/A	KF090CP0*RBC
	30	7.20	3.266	16,420	73,040	9,720	43,240	N/A	N/A	N/A	N/A	N/A	N/A	N/A	N/A	KG090CP0*RBC
	123	0.50	0.227	3,110	13,830	990	4,400	N/A	N/A	N/A	N/A	N/A	N/A	N/A	N/A	KA100CP0*RBC
	103	0.73	0.331	4,190	18,640	1,400	6,230	N/A	N/A	N/A	N/A	N/A	N/A	N/A	N/A	KB100CP0*RBC
	83	1.06	0.481	4,990	22,200	1,781	7,920	N/A	N/A	N/A	N/A	N/A	N/A	N/A	N/A	KC100CP0*RBC
	63	1.88	0.853	7,180	31,940	3,070	13,660	N/A	N/A	N/A	N/A	N/A	N/A	N/A	N/A	KD100CP0*RBC
	43	4.30	1.950	12,130	53,960	5,550	24,690	N/A	N/A	N/A	N/A	N/A	N/A	N/A	N/A	KF100CP0*RBC
	33	7.90	3.583	18,060	80,330	10,040	44,660	N/A	N/A	N/A	N/A	N/A	N/A	N/A	N/A	KG100CP0*RBC

THIN SECTION BALL BEARINGS

THIN SECTION BALL BEARINGS — RADIAL CONTACT, C-TYPE



RADIAL CONTACT, C-TYPE

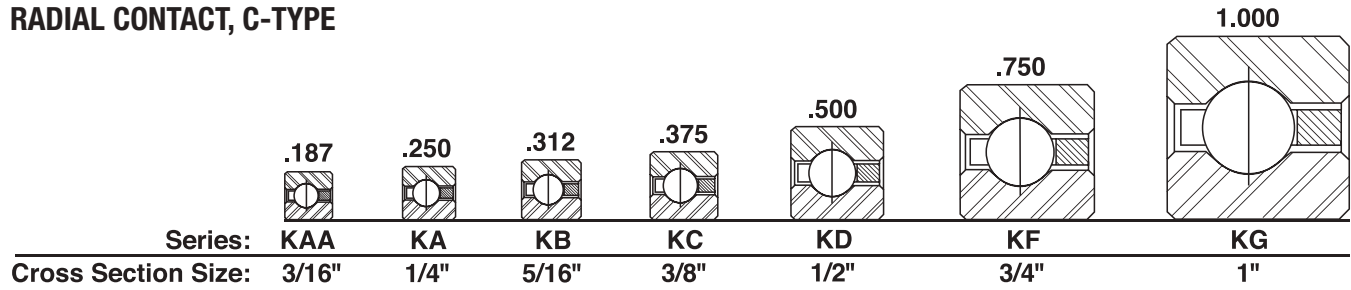

PART NUMBER*	NOMINAL DIMENSIONS												
	B Bore		D Outside Diameter		W Width		Land Diameter		f ₁ Housing Fillet		Ball Diameter		
	in.	mm	in.	mm	in.	mm	L _i -Inner Ring	L _o -Outer Ring	in.	mm			
KA110CP0*RBC	11.0000	279.400	11.5000	292.100	0.2500	6.350	11.188	284.18	11.313	287.35	0.025	0.64	1/8
KB110CP0*RBC	11.0000	279.400	11.6250	295.275	0.3125	7.938	11.234	285.34	11.391	289.33	0.032	0.81	5/32
KC110CP0*RBC	11.0000	279.400	11.7500	298.450	0.3750	9.525	11.281	286.54	11.469	291.31	0.040	1.02	3/16
KD110CP0*RBC	11.0000	279.400	12.0000	304.800	0.5000	12.700	11.375	288.93	11.625	295.28	0.060	1.52	1/4
KF110CP0*RBC	11.0000	279.400	12.5000	317.500	0.7500	19.050	11.563	293.70	11.938	303.23	0.080	2.03	3/8
KG110CP0*RBC	11.0000	279.400	13.0000	330.200	1.0000	25.400	11.750	298.45	12.250	311.15	0.080	2.03	1/2
KA120CP0*RBC	12.0000	304.800	12.5000	317.500	0.2500	6.350	12.188	309.58	12.313	312.75	0.025	0.64	1/8
KB120CP0*RBC	12.0000	304.800	12.6250	320.675	0.3125	7.938	12.234	310.74	12.391	314.73	0.032	0.81	5/32
KC120CP0*RBC	12.0000	304.800	12.7500	323.850	0.3750	9.525	12.281	311.94	12.469	316.71	0.040	1.02	3/16
KD120CP0*RBC	12.0000	304.800	13.0000	330.200	0.5000	12.700	12.375	314.33	12.625	320.68	0.060	1.52	1/4
KF120CP0*RBC	12.0000	304.800	13.5000	342.900	0.7500	19.050	12.563	319.10	12.938	328.63	0.080	2.03	3/8
KG120CP0*RBC	12.0000	304.800	14.0000	355.600	1.0000	25.400	12.750	323.85	13.250	336.55	0.080	2.03	1/2
KB140CP0*RBC	14.0000	355.600	14.6250	371.475	0.3125	7.938	14.234	361.54	14.391	365.53	0.032	0.81	5/32
KC140CP0*RBC	14.0000	355.600	14.7500	374.650	0.3750	9.525	14.281	362.74	14.469	367.51	0.040	1.02	3/16
KD140CP0*RBC	14.0000	355.600	15.0000	381.000	0.5000	12.700	14.375	365.13	14.625	371.48	0.060	1.52	1/4
KF140CP0*RBC	14.0000	355.600	15.5000	393.700	0.7500	19.050	14.563	369.90	14.938	379.43	0.080	2.03	3/8
KG140CP0*RBC	14.0000	355.600	16.0000	406.400	1.0000	25.400	14.750	374.65	15.250	387.35	0.080	2.03	1/2
KB160CP0*RBC	16.0000	406.400	16.6250	422.275	0.3125	7.938	16.234	412.34	16.391	416.33	0.032	0.81	5/32
KC160CP0*RBC	16.0000	406.400	16.7500	425.450	0.3750	9.525	16.281	413.54	16.469	418.31	0.040	1.02	3/16
KD160CP0*RBC	16.0000	406.400	17.0000	431.800	0.5000	12.700	16.375	415.93	16.625	422.28	0.060	1.52	1/4
KF160CP0*RBC	16.0000	406.400	17.5000	444.500	0.7500	19.050	16.563	420.70	16.938	430.23	0.080	2.03	3/8
KG160CP0*RBC	16.0000	406.400	18.0000	457.200	1.0000	25.400	16.750	425.45	17.250	438.15	0.080	2.03	1/2
KB180CP0*RBC	18.0000	457.200	18.6250	473.075	0.3125	7.938	18.234	463.14	18.391	467.13	0.032	0.81	5/32
KC180CP0*RBC	18.0000	457.200	18.7500	476.250	0.3750	9.525	18.281	464.34	18.469	469.11	0.040	1.02	3/16
KD180CP0*RBC	18.0000	457.200	19.0000	482.600	0.5000	12.700	18.375	466.73	18.625	473.08	0.060	1.52	1/4
KF180CP0*RBC	18.0000	457.200	19.5000	495.300	0.7500	19.050	18.563	471.50	18.938	481.03	0.080	2.03	3/8
KG180CP0*RBC	18.0000	457.200	20.0000	508.000	1.0000	25.400	18.750	476.25	19.250	488.95	0.080	2.03	1/2
KB200CP0*RBC	20.0000	508.000	20.6250	523.875	0.3125	7.938	20.234	513.94	20.391	517.93	0.032	0.81	5/32
KC200CP0*RBC	20.0000	508.000	20.7500	527.050	0.3750	9.525	20.281	515.14	20.469	519.91	0.040	1.02	3/16
KD200CP0*RBC	20.0000	508.000	21.0000	533.400	0.5000	12.700	20.375	517.53	20.625	523.88	0.060	1.52	1/4
KF200CP0*RBC	20.0000	508.000	21.5000	546.100	0.7500	19.050	20.563	522.30	20.938	531.83	0.080	2.03	3/8
KG200CP0*RBC	20.0000	508.000	22.0000	558.800	1.0000	25.400	20.750	527.05	21.250	539.75	0.080	2.03	1/2
KC250CP0*RBC	25.0000	635.000	25.7500	654.050	0.3750	9.525	25.281	642.14	25.469	646.91	0.040	1.02	3/16
KD250CP0*RBC	25.0000	635.000	26.0000	660.400	0.5000	12.700	25.375	644.53	25.625	650.88	0.060	1.52	1/4
KF250CP0*RBC	25.0000	635.000	26.5000	673.100	0.7500	19.050	25.563	649.30	25.938	658.83	0.080	2.03	3/8
KG250CP0*RBC	25.0000	635.000	27.0000	685.800	1.0000	25.400	25.750	654.05	26.250	666.75	0.080	2.03	1/2
KC300CP0*RBC	30.0000	762.000	30.7500	781.050	0.3750	9.525	30.281	769.14	30.469	773.91	0.040	1.02	3/16
KD300CP0*RBC	30.0000	762.000	31.0000	787.400	0.5000	12.700	30.375	771.53	30.625	777.88	0.060	1.52	1/4
KF300CP0*RBC	30.0000	762.000	31.5000	800.100	0.7500	19.050	30.563	776.30	30.938	785.83	0.080	2.03	3/8
KG300CP0*RBC	30.0000	762.000	32.0000	812.800	1.0000	25.400	30.750	781.05	31.250	793.75	0.080	2.03	1/2
KF350CP0*RBC	35.0000	889.000	36.5000	927.100	0.7500	19.050	35.563	903.30	35.938	912.83	0.080	2.03	3/8
KG350CP0*RBC	35.0000	889.000	37.0000	939.800	1.0000	25.400	35.750	908.05	36.250	920.75	0.080	2.03	1/2
KF400CP0*RBC	40.0000	1016.000	41.5000	1054.100	0.7500	19.050	40.563	1030.30	40.938	1039.83	0.080	2.03	3/8
KG400CP0*RBC	40.0000	1016.000	42.0000	1066.800	1.0000	25.400	40.750	1035.05	41.250	1047.75	0.080	2.03	1/2

*The alphanumeric identification system is used under license.

© 2008, 2011, 2018 RBC Bearings Incorporated. All rights reserved.

THIN SECTION BALL BEARINGS

THIN SECTION BALL BEARINGS — RADIAL CONTACT, C-TYPE



- 52100 steel
- Large diameter
- Light weight
- Small cross-section
- Snap-over ball separator

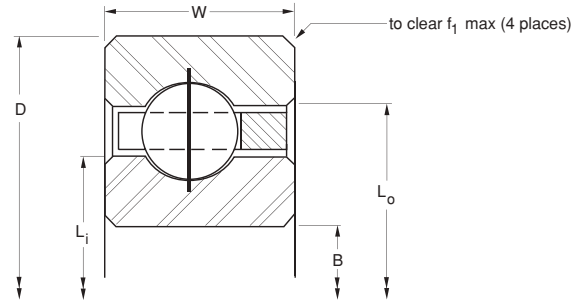

	Ball Quantity	Approx. Weight		LOAD RATINGS										PART NUMBER*		
				Radial		Thrust				Moment						
				Static	Dynamic	Static	Dynamic	Static	Dynamic	Static	Dynamic					
lbs.	kg	lbf	N	lbf	N	lbf	N	lbf - in	Nm	lbf - in	Nm					
	135	0.52	0.236	3,410	15,170	1,030	4,580	N/A	N/A	N/A	N/A	N/A	N/A	N/A	N/A	KA110CP0*RBC
	113	0.75	0.340	4,590	20,420	1,464	6,510	N/A	N/A	N/A	N/A	N/A	N/A	N/A	N/A	KB110CP0*RBC
	91	1.16	0.526	5,470	24,330	1,879	8,360	N/A	N/A	N/A	N/A	N/A	N/A	N/A	N/A	KC110CP0*RBC
	69	2.06	0.934	7,870	35,010	3,180	14,150	N/A	N/A	N/A	N/A	N/A	N/A	N/A	N/A	KD110CP0*RBC
	47	4.80	2.177	13,260	58,980	5,833	25,950	N/A	N/A	N/A	N/A	N/A	N/A	N/A	N/A	KF110CP0*RBC
	36	8.60	3.901	19,700	87,630	10,360	46,080	N/A	N/A	N/A	N/A	N/A	N/A	N/A	N/A	KG110CP0*RBC
	147	0.56	0.254	3,720	16,550	1,078	4,800	N/A	N/A	N/A	N/A	N/A	N/A	N/A	N/A	KA120CP0*RBC
	123	0.83	0.376	5,000	22,240	1,539	6,850	N/A	N/A	N/A	N/A	N/A	N/A	N/A	N/A	KB120CP0*RBC
	99	1.25	0.567	5,950	26,470	1,974	8,780	N/A	N/A	N/A	N/A	N/A	N/A	N/A	N/A	KC120CP0*RBC
	75	2.25	1.021	8,550	38,030	3,320	14,770	N/A	N/A	N/A	N/A	N/A	N/A	N/A	N/A	KD120CP0*RBC
	51	5.20	2.359	14,390	64,010	6,105	27,160	N/A	N/A	N/A	N/A	N/A	N/A	N/A	N/A	KF120CP0*RBC
	39	9.30	4.218	21,340	94,930	10,690	47,550	N/A	N/A	N/A	N/A	N/A	N/A	N/A	N/A	KG120CP0*RBC
	143	1.05	0.476	5,810	25,840	1,680	7,470	N/A	N/A	N/A	N/A	N/A	N/A	N/A	N/A	KB140CP0*RBC
	115	1.52	0.689	6,910	30,740	2,154	9,580	N/A	N/A	N/A	N/A	N/A	N/A	N/A	N/A	KC140CP0*RBC
	87	2.73	1.238	9,920	44,130	3,460	15,390	N/A	N/A	N/A	N/A	N/A	N/A	N/A	N/A	KD140CP0*RBC
	59	6.00	2.722	16,650	74,060	6,620	29,450	N/A	N/A	N/A	N/A	N/A	N/A	N/A	N/A	KF140CP0*RBC
	45	10.80	4.899	24,620	109,520	11,280	50,180	N/A	N/A	N/A	N/A	N/A	N/A	N/A	N/A	KG140CP0*RBC
	163	1.20	0.544	6,620	29,450	1,812	8,060	N/A	N/A	N/A	N/A	N/A	N/A	N/A	N/A	KB160CP0*RBC
	131	1.73	0.785	7,880	35,050	2,321	10,320	N/A	N/A	N/A	N/A	N/A	N/A	N/A	N/A	KC160CP0*RBC
	99	3.10	1.406	11,290	50,220	3,688	16,410	N/A	N/A	N/A	N/A	N/A	N/A	N/A	N/A	KD160CP0*RBC
	67	7.10	3.221	18,900	84,070	7,104	31,600	N/A	N/A	N/A	N/A	N/A	N/A	N/A	N/A	KF160CP0*RBC
	51	12.30	5.579	27,910	124,150	11,820	52,580	N/A	N/A	N/A	N/A	N/A	N/A	N/A	N/A	KG160CP0*RBC
	183	1.35	0.612	7,440	33,090	1,936	8,610	N/A	N/A	N/A	N/A	N/A	N/A	N/A	N/A	KB180CP0*RBC
	147	1.94	0.880	8,840	39,320	2,478	11,020	N/A	N/A	N/A	N/A	N/A	N/A	N/A	N/A	KC180CP0*RBC
	111	3.48	1.579	12,650	56,270	3,933	17,490	N/A	N/A	N/A	N/A	N/A	N/A	N/A	N/A	KD180CP0*RBC
	75	7.90	3.583	21,160	94,120	7,557	33,620	N/A	N/A	N/A	N/A	N/A	N/A	N/A	N/A	KF180CP0*RBC
	57	13.70	6.214	31,190	138,740	12,367	55,010	N/A	N/A	N/A	N/A	N/A	N/A	N/A	N/A	KG180CP0*RBC
	203	1.50	0.680	8,250	36,700	2,053	9,130	N/A	N/A	N/A	N/A	N/A	N/A	N/A	N/A	KB200CP0*RBC
	163	2.16	0.980	9,800	43,590	2,626	11,680	N/A	N/A	N/A	N/A	N/A	N/A	N/A	N/A	KC200CP0*RBC
	123	3.85	1.746	14,020	62,360	4,164	18,520	N/A	N/A	N/A	N/A	N/A	N/A	N/A	N/A	KD200CP0*RBC
	83	8.90	4.037	23,420	104,180	7,986	35,520	N/A	N/A	N/A	N/A	N/A	N/A	N/A	N/A	KF200CP0*RBC
	63	15.80	7.167	34,470	153,330	13,044	58,020	N/A	N/A	N/A	N/A	N/A	N/A	N/A	N/A	KG200CP0*RBC
	203	2.69	1.220	12,200	54,270	2,962	13,180	N/A	N/A	N/A	N/A	N/A	N/A	N/A	N/A	KC250CP0*RBC
	153	4.79	2.173	17,440	77,580	4,689	20,860	N/A	N/A	N/A	N/A	N/A	N/A	N/A	N/A	KD250CP0*RBC
	103	10.90	4.944	29,060	129,270	8,963	39,870	N/A	N/A	N/A	N/A	N/A	N/A	N/A	N/A	KF250CP0*RBC
	78	19.50	8.845	42,680	189,850	14,591	64,900	N/A	N/A	N/A	N/A	N/A	N/A	N/A	N/A	KG250CP0*RBC
	243	3.21	1.456	14,610	64,990	3,260	14,500	N/A	N/A	N/A	N/A	N/A	N/A	N/A	N/A	KC300CP0*RBC
	183	5.73	2.599	20,860	92,790	5,153	22,920	N/A	N/A	N/A	N/A	N/A	N/A	N/A	N/A	KD300CP0*RBC
	123	13.00	5.897	34,700	154,350	9,828	43,720	N/A	N/A	N/A	N/A	N/A	N/A	N/A	N/A	KF300CP0*RBC
	93	23.30	10.569	50,890	226,370	15,963	71,010	N/A	N/A	N/A	N/A	N/A	N/A	N/A	N/A	KG300CP0*RBC
	143	15.10	6.849	40,350	179,490	10,603	47,160	N/A	N/A	N/A	N/A	N/A	N/A	N/A	N/A	KF350CP0*RBC
	108	27.10	12.292	59,100	262,890	17,195	76,490	N/A	N/A	N/A	N/A	N/A	N/A	N/A	N/A	KG350CP0*RBC
	163	17.20	7.802	45,990	204,570	11,302	50,270	N/A	N/A	N/A	N/A	N/A	N/A	N/A	N/A	KF400CP0*RBC
	123	30.80	13.971	67,310	299,410	18,307	81,430	N/A	N/A	N/A	N/A	N/A	N/A	N/A	N/A	KG400CP0*RBC

Refer to the Engineering section for load and speed limitations.

© 2008, 2011, 2018 RBC Bearings Incorporated. All rights reserved.

THIN SECTION BALL BEARINGS

THIN SECTION BALL BEARINGS — ANGULAR CONTACT, A-TYPE



ANGULAR CONTACT, A-TYPE

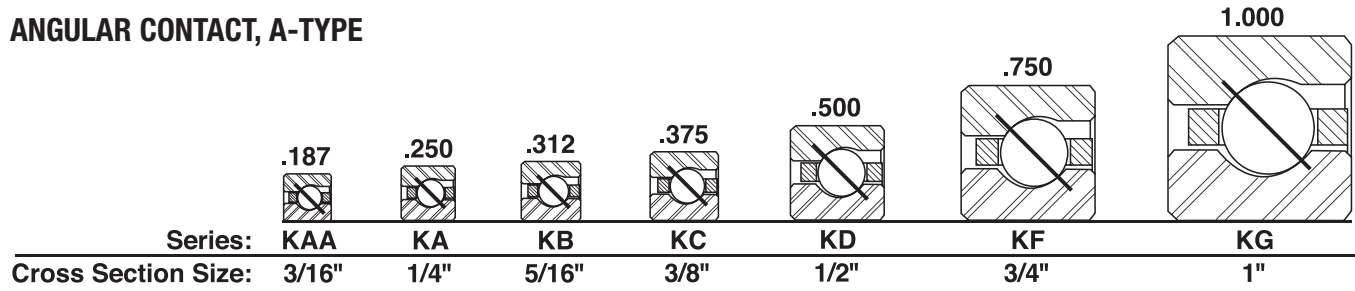

PART NUMBER*	NOMINAL DIMENSIONS														
	B Bore	D Outside Diameter		W Width		Land Diameter			f ₁ Housing Fillet		Ball Diameter				
		in. mm	in. mm	in. mm	in. mm	L _i -Inner Ring in. mm	L _o -Outer Ring in. mm	L _s -Counter Bore in. mm	in. mm	in. mm					
KAA10AG0*RBC	1.0000	25.400	1.3750	34.925	0.1875	4.763	1.141	28.98	1.234	31.34	1.235	31.37	0.015	0.38	3/32
KAA15AG0*RBC	1.5000	38.100	1.8750	47.625	0.1875	4.763	1.641	41.68	1.734	44.04	1.735	44.07	0.015	0.38	3/32
KA020AR0*RBC	2.0000	50.800	2.5000	63.500	0.2500	6.350	2.188	55.58	2.313	58.75	2.375	60.33	0.025	0.64	1/8
KB020AR0*RBC	2.0000	50.800	2.6250	66.675	0.3125	7.938	2.234	56.74	2.391	60.73	2.469	62.71	0.032	0.81	5/32
KA025AR0*RBC	2.5000	63.500	3.0000	76.200	0.2500	6.350	2.688	68.28	2.813	71.45	2.875	73.03	0.025	0.64	1/8
KB025AR0*RBC	2.5000	63.500	3.1250	79.375	0.3125	7.938	2.734	69.44	2.891	73.43	2.969	75.41	0.032	0.81	5/32
KA030AR0*RBC	3.0000	76.200	3.5000	88.900	0.2500	6.350	3.188	80.98	3.313	84.15	3.375	85.73	0.025	0.64	1/8
KB030AR0*RBC	3.0000	76.200	3.6250	92.075	0.3125	7.938	3.234	82.14	3.391	86.13	3.469	88.11	0.032	0.81	5/32
KA035AR0*RBC	3.5000	88.900	4.0000	101.600	0.2500	6.350	3.688	93.68	3.813	96.85	3.875	98.43	0.025	0.64	1/8
KB035AR0*RBC	3.5000	88.900	4.1250	104.775	0.3125	7.938	3.734	94.84	3.891	98.83	3.969	100.81	0.032	0.81	5/32
KA040AR0*RBC	4.0000	101.600	4.5000	114.300	0.2500	6.350	4.188	106.38	4.313	109.55	4.375	111.13	0.025	0.64	1/8
KB040AR0*RBC	4.0000	101.600	4.6250	117.475	0.3125	7.938	4.234	107.54	4.391	111.53	4.469	113.51	0.032	0.81	5/32
KA040AR0*RBC	4.0000	101.600	4.7500	120.650	0.3750	9.525	4.281	108.74	4.469	113.51	4.563	115.90	0.040	1.02	3/16
KD040AR0*RBC	4.0000	101.600	5.0000	127.000	0.5000	12.700	4.375	111.13	4.625	117.48	4.750	120.65	0.060	1.52	1/4
KF040AR0*RBC	4.0000	101.600	5.5000	139.700	0.7500	19.050	4.563	115.90	4.938	125.43	5.125	130.18	0.080	2.03	3/8
KG040AR0*RBC	4.0000	101.600	6.0000	152.400	1.0000	25.400	4.750	120.65	5.250	133.35	5.500	139.70	0.080	2.03	1/2
KA042AR0*RBC	4.2500	107.950	4.7500	120.650	0.2500	6.350	4.438	112.73	4.563	115.90	4.625	117.48	0.025	0.64	1/8
KB042AR0*RBC	4.2500	107.950	4.8750	123.825	0.3125	7.938	4.484	113.89	4.641	117.88	4.719	119.86	0.032	0.81	5/32
KA042AR0*RBC	4.2500	107.950	5.0000	127.000	0.3750	9.525	4.531	115.09	4.719	119.86	4.813	122.25	0.040	1.02	3/16
KD042AR0*RBC	4.2500	107.950	5.2500	133.350	0.5000	12.700	4.625	117.48	4.875	123.83	5.000	127.00	0.060	1.52	1/4
KF042AR0*RBC	4.2500	107.950	5.7500	146.050	0.7500	19.050	4.813	122.25	5.188	131.78	5.375	136.53	0.080	2.03	3/8
KG042AR0*RBC	4.2500	107.950	6.2500	158.750	1.0000	25.400	5.000	127.00	5.500	139.70	5.750	146.05	0.080	2.03	1/2
KA045AR0*RBC	4.5000	114.300	5.0000	127.000	0.2500	6.350	4.688	119.08	4.813	122.25	4.875	123.83	0.025	0.64	1/8
KB045AR0*RBC	4.5000	114.300	5.1250	130.175	0.3125	7.938	4.734	120.24	4.891	124.23	4.969	126.21	0.032	0.81	5/32
KA045AR0*RBC	4.5000	114.300	5.2500	133.350	0.3750	9.525	4.781	121.44	4.969	126.21	5.063	128.60	0.040	1.02	3/16
KD045AR0*RBC	4.5000	114.300	5.5000	139.700	0.5000	12.700	4.875	123.83	5.125	130.18	5.250	133.35	0.060	1.52	1/4
KF045AR0*RBC	4.5000	114.300	6.0000	152.400	0.7500	19.050	5.063	128.60	5.438	138.13	5.625	142.88	0.080	2.03	3/8
KG045AR0*RBC	4.5000	114.300	6.5000	165.100	1.0000	25.400	5.250	133.35	5.750	146.05	6.000	152.40	0.080	2.03	1/2
KA047AR0*RBC	4.7500	120.650	5.2500	133.350	0.2500	6.350	4.938	125.43	5.063	128.60	5.125	130.18	0.025	0.64	1/8
KB047AR0*RBC	4.7500	120.650	5.3750	136.525	0.3125	7.938	4.984	126.59	5.141	130.58	5.219	132.56	0.032	0.81	5/32
KA047AR0*RBC	4.7500	120.650	5.5000	139.700	0.3750	9.525	5.031	127.79	5.219	132.56	5.313	134.95	0.040	1.02	3/16
KD047AR0*RBC	4.7500	120.650	5.7500	146.050	0.5000	12.700	5.125	130.18	5.375	136.53	5.500	139.70	0.060	1.52	1/4
KF047AR0*RBC	4.7500	120.650	6.2500	158.750	0.7500	19.050	5.313	134.95	5.688	144.48	5.875	149.23	0.080	2.03	3/8
KG047AR0*RBC	4.7500	120.650	6.7500	171.450	1.0000	25.400	5.500	139.70	6.000	152.40	6.250	158.75	0.080	2.03	1/2
KA050AR0*RBC	5.0000	127.000	5.5000	139.700	0.2500	6.350	5.188	131.78	5.313	134.95	5.375	136.53	0.025	0.64	1/8
KB050AR0*RBC	5.0000	127.000	5.6250	142.875	0.3125	7.938	5.234	132.94	5.391	136.93	5.469	138.91	0.032	0.81	5/32
KA050AR0*RBC	5.0000	127.000	5.7500	146.050	0.3750	9.525	5.281	134.14	5.469	138.91	5.563	141.30	0.040	1.02	3/16
KD050AR0*RBC	5.0000	127.000	6.0000	152.400	0.5000	12.700	5.375	136.53	5.625	142.88	5.750	146.05	0.060	1.52	1/4
KF050AR0*RBC	5.0000	127.000	6.5000	165.100	0.7500	19.050	5.563	141.30	5.938	150.83	6.125	155.58	0.080	2.03	3/8
KG050AR0*RBC	5.0000	127.000	7.0000	177.800	1.0000	25.400	5.750	146.05	6.250	158.75	6.500	165.10	0.080	2.03	1/2
KA055AR0*RBC	5.5000	139.700	6.0000	152.400	0.2500	6.350	5.688	144.48	5.813	147.65	5.875	149.23	0.025	0.64	1/8
KB055AR0*RBC	5.5000	139.700	6.1250	155.575	0.3125	7.938	5.734	145.64	5.891	149.63	5.969	151.61	0.032	0.81	5/32
KA055AR0*RBC	5.5000	139.700	6.2500	158.750	0.3750	9.525	5.781	146.84	5.969	151.61	6.063	154.00	0.040	1.02	3/16
KD055AR0*RBC	5.5000	139.700	6.5000	165.100	0.5000	12.700	5.875	149.23	6.125	155.58	6.250	158.75	0.060	1.52	1/4
KF055AR0*RBC	5.5000	139.700	7.0000	177.800	0.7500	19.050	6.063	154.00	6.438	163.53	6.625	168.28	0.080	2.03	3/8
KG055AR0*RBC	5.5000	139.700	7.5000	190.500	1.0000	25.400	6.250	158.75	6.750	171.45	7.000	177.80	0.080	2.03	1/2

*The alphanumeric identification system is used under license.

© 2008, 2011, 2018 RBC Bearings Incorporated. All rights reserved.

THIN SECTION BALL BEARINGS

THIN SECTION BALL BEARINGS — ANGULAR CONTACT, A-TYPE



- 52100 steel
- Large diameter
- Light weight
- Small cross-section
- Circular pocket ball separator

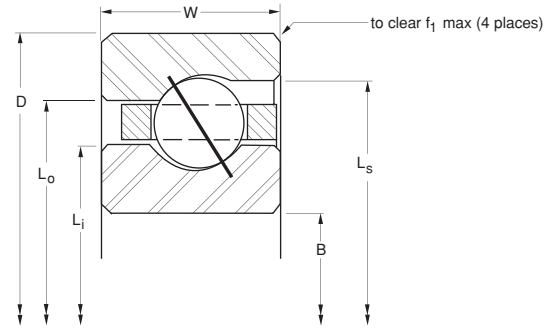

	Ball Quantity	Approx. Weight		LOAD RATINGS										PART NUMBER*	
				Radial				Thrust				Moment			
				Static lbf	N	Dynamic lbf	N	Static lbf	N	Dynamic lbf	N	Static lbf - in	Nm		Dynamic lbf - in
28	0.03	0.014	340	1,510	330	1,470	970	4,310	960	4,270	N/A	N/A	N/A	N/A	KAA10AG0*RBC
40	0.04	0.018	480	2,140	380	1,690	1,380	6,140	1,100	4,890	N/A	N/A	N/A	N/A	KAA15AG0*RBC
36	0.10	0.045	790	3,510	6,600	29,360	2,280	10,140	1,730	7,700	N/A	N/A	N/A	N/A	KA020AR0*RBC
31	0.16	0.073	1,090	4,850	850	3,780	3,150	14,010	2,460	10,940	N/A	N/A	N/A	N/A	KB020AR0*RBC
44	0.13	0.059	960	4,270	640	2,850	2,780	12,370	1,860	8,270	N/A	N/A	N/A	N/A	KA025AR0*RBC
38	0.20	0.091	1,340	5,960	920	4,090	3,860	17,170	2,680	11,920	N/A	N/A	N/A	N/A	KB025AR0*RBC
52	0.15	0.068	1,140	5,070	680	3,020	3,290	14,630	1,980	8,810	N/A	N/A	N/A	N/A	KA030AR0*RBC
44	0.24	0.109	1,550	6,890	970	4,310	4,470	19,880	2,800	12,460	N/A	N/A	N/A	N/A	KB030AR0*RBC
60	0.18	0.082	1,310	5,830	720	3,200	3,790	16,860	2,070	9,210	N/A	N/A	N/A	N/A	KA035AR0*RBC
51	0.27	0.122	1,790	7,960	1,020	4,540	5,180	23,040	2,970	13,210	N/A	N/A	N/A	N/A	KB035AR0*RBC
68	0.19	0.086	1,490	6,630	750	3,340	4,300	19,130	2,180	9,700	N/A	N/A	N/A	N/A	KA040AR0*RBC
58	0.30	0.136	2,040	9,070	1,080	4,800	5,890	26,200	3,130	13,920	N/A	N/A	N/A	N/A	KB040AR0*RBC
49	0.45	0.204	2,550	11,340	1,410	6,270	7,360	32,740	4,080	18,150	N/A	N/A	N/A	N/A	KC040AR0*RBC
36	0.78	0.354	3,550	15,790	2,070	9,210	10,260	45,640	6,020	26,780	N/A	N/A	N/A	N/A	KD040AR0*RBC
26	1.90	0.862	6,350	28,250	4,350	19,350	18,340	81,580	12,620	56,140	N/A	N/A	N/A	N/A	KF040AR0*RBC
20	3.60	1.633	9,480	42,170	7,340	32,650	27,360	121,700	21,290	94,700	N/A	N/A	N/A	N/A	KG040AR0*RBC
72	0.20	0.091	1,580	7,030	770	3,430	4,550	20,240	2,240	9,960	N/A	N/A	N/A	N/A	KA042AR0*RBC
61	0.31	0.141	2,150	9,560	1,090	4,850	6,200	27,580	3,170	14,100	N/A	N/A	N/A	N/A	KB042AR0*RBC
52	0.47	0.213	2,710	12,050	1,440	6,410	7,820	34,790	4,180	18,590	N/A	N/A	N/A	N/A	KC042AR0*RBC
38	0.83	0.376	3,750	16,680	2,410	10,720	10,830	48,170	6,990	31,090	N/A	N/A	N/A	N/A	KD042AR0*RBC
27	2.00	0.907	6,600	29,360	4,390	19,530	19,050	84,740	12,740	56,670	N/A	N/A	N/A	N/A	KF042AR0*RBC
21	3.80	1.724	9,950	44,260	7,580	33,720	28,730	127,800	21,990	97,820	N/A	N/A	N/A	N/A	KG042AR0*RBC
76	0.22	0.100	1,660	7,380	780	3,470	4,810	21,400	2,260	10,050	N/A	N/A	N/A	N/A	KA045AR0*RBC
64	0.33	0.150	16,800	74,730	1,120	4,980	6,500	28,910	3,240	14,410	N/A	N/A	N/A	N/A	KB045AR0*RBC
55	0.48	0.218	2,860	12,720	1,470	6,540	8,270	36,790	4,260	18,950	N/A	N/A	N/A	N/A	KC045AR0*RBC
40	0.88	0.399	3,950	17,570	2,460	10,940	11,400	50,710	7,140	31,760	N/A	N/A	N/A	N/A	KD045AR0*RBC
29	2.10	0.953	7,090	31,540	4,550	20,240	20,460	91,010	13,200	58,720	N/A	N/A	N/A	N/A	KF045AR0*RBC
22	4.00	1.814	10,430	46,390	7,820	34,790	30,100	133,890	22,690	100,930	N/A	N/A	N/A	N/A	KG045AR0*RBC
80	0.23	0.104	1,750	7,780	800	3,560	5,060	22,510	2,310	10,280	N/A	N/A	N/A	N/A	KA047AR0*RBC
68	0.34	0.154	2,390	10,630	1,140	5,070	6,910	30,740	3,290	14,630	N/A	N/A	N/A	N/A	KB047AR0*RBC
58	0.50	0.227	3,020	13,430	1,500	6,670	8,720	38,790	4,340	19,310	N/A	N/A	N/A	N/A	KC047AR0*RBC
42	0.94	0.426	4,150	18,460	2,510	11,170	11,970	53,250	7,280	32,380	N/A	N/A	N/A	N/A	KD047AR0*RBC
30	2.20	0.998	7,330	32,610	4,610	20,510	21,160	94,120	13,380	59,520	N/A	N/A	N/A	N/A	KF047AR0*RBC
23	4.10	1.860	10,900	48,490	8,060	35,850	31,460	139,940	23,370	103,950	N/A	N/A	N/A	N/A	KG047AR0*RBC
84	0.24	0.109	1,840	8,180	810	3,600	5,310	23,620	2,360	10,500	N/A	N/A	N/A	N/A	KA050AR0*RBC
71	0.38	0.172	2,500	11,120	1,160	5,160	7,210	32,070	3,350	14,900	N/A	N/A	N/A	N/A	KB050AR0*RBC
61	0.58	0.263	3,180	14,150	1,540	6,850	9,170	40,790	4,450	19,790	N/A	N/A	N/A	N/A	KC050AR0*RBC
44	1.00	0.454	4,340	19,310	2,550	11,340	12,540	55,780	7,400	32,920	N/A	N/A	N/A	N/A	KD050AR0*RBC
31	2.30	1.043	7,570	33,670	4,650	20,680	21,870	97,280	13,480	59,960	N/A	N/A	N/A	N/A	KF050AR0*RBC
24	4.30	1.950	11,370	50,580	8,290	36,880	32,830	146,040	24,040	106,940	N/A	N/A	N/A	N/A	KG050AR0*RBC
92	0.25	0.113	2,020	8,990	830	3,690	5,820	25,890	2,410	10,720	N/A	N/A	N/A	N/A	KA055AR0*RBC
78	0.41	0.186	2,740	12,190	1,200	5,340	7,920	35,230	3,480	15,480	N/A	N/A	N/A	N/A	KB055AR0*RBC
66	0.59	0.268	3,440	15,300	1,560	6,940	9,920	44,130	4,540	20,190	N/A	N/A	N/A	N/A	KC055AR0*RBC
48	1.06	0.481	4,740	21,080	2,640	11,740	13,680	60,850	7,660	34,070	N/A	N/A	N/A	N/A	KD055AR0*RBC
34	2.50	1.134	8,310	36,960	4,820	21,440	23,980	106,670	13,980	62,190	N/A	N/A	N/A	N/A	KF055AR0*RBC
26	4.70	2.132	12,320	54,800	8,610	38,300	35,570	158,220	24,960	111,030	N/A	N/A	N/A	N/A	KG055AR0*RBC

Refer to the Engineering section for load and speed limitations.

© 2008, 2011, 2018 RBC Bearings Incorporated. All rights reserved.

THIN SECTION BALL BEARINGS

THIN SECTION BALL BEARINGS — ANGULAR CONTACT, A-TYPE



ANGULAR CONTACT, A-TYPE

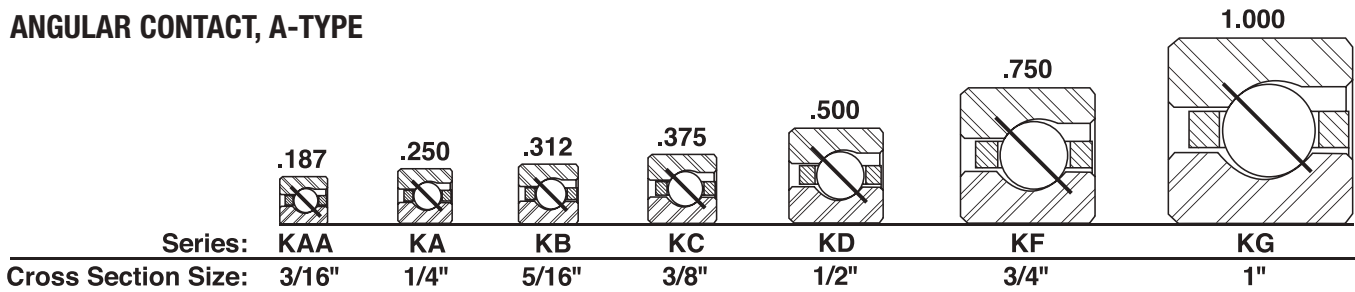

PART NUMBER*	NOMINAL DIMENSIONS														
	B Bore		D Outside Diameter		W Width		Land Diameter			f ₁ Housing Fillet		Ball Diameter			
	in.	mm	in.	mm	in.	mm	L _i - Inner Ring	L _o - Outer Ring	L _s - Counter Bore	in.	mm		in.		
KA060ARO*RBC	6.0000	152.400	6.5000	165.100	0.2500	6.350	6.188	157.18	6.313	160.35	6.375	161.93	0.025	0.64	1/8
KB060ARO*RBC	6.0000	152.400	6.6250	168.275	0.3125	7.938	6.234	158.34	6.391	162.33	6.469	164.31	0.032	0.81	5/32
KC060ARO*RBC	6.0000	152.400	6.7500	171.450	0.3750	9.525	6.281	159.54	6.469	164.31	6.563	166.70	0.040	1.02	3/16
KD060ARO*RBC	6.0000	152.400	7.0000	177.800	0.5000	12.700	6.375	161.93	6.625	168.28	6.750	171.45	0.060	1.52	1/4
KF060ARO*RBC	6.0000	152.400	7.5000	190.500	0.7500	19.050	6.563	166.70	6.938	176.23	7.125	180.98	0.080	2.03	3/8
KG060ARO*RBC	6.0000	152.400	8.0000	203.200	1.0000	25.400	6.750	171.45	7.250	184.15	7.500	190.50	0.080	2.03	1/2
KA065ARO*RBC	6.5000	165.100	7.0000	177.800	0.2500	6.350	6.688	169.88	6.813	173.05	6.875	174.63	0.025	0.64	1/8
KB065ARO*RBC	6.5000	165.100	7.1250	180.975	0.3125	7.938	6.734	171.04	6.891	175.03	6.969	177.01	0.032	0.81	5/32
KC065ARO*RBC	6.5000	165.100	7.2500	184.150	0.3750	9.525	6.781	172.24	6.969	177.01	7.063	179.40	0.040	1.02	3/16
KD065ARO*RBC	6.5000	165.100	7.5000	190.500	0.5000	12.700	6.875	174.63	7.125	180.98	7.250	184.15	0.060	1.52	1/4
KF065ARO*RBC	6.5000	165.100	8.0000	203.200	0.7500	19.050	7.063	179.40	7.438	188.93	7.625	193.68	0.080	2.03	3/8
KG065ARO*RBC	6.5000	165.100	8.5000	215.900	1.0000	25.400	7.250	184.15	7.750	196.85	8.000	203.20	0.080	2.03	1/2
KA070ARO*RBC	7.0000	177.800	7.5000	190.500	0.2500	6.350	7.188	182.58	7.313	185.75	7.375	187.33	0.025	0.64	1/8
KB070ARO*RBC	7.0000	177.800	7.6250	193.675	0.3125	7.938	7.234	183.74	7.391	187.73	7.469	189.71	0.032	0.81	5/32
KC070ARO*RBC	7.0000	177.800	7.7500	196.850	0.3750	9.525	7.281	184.94	7.469	189.71	7.563	192.10	0.040	1.02	3/16
KD070ARO*RBC	7.0000	177.800	8.0000	203.200	0.5000	12.700	7.375	187.33	7.625	193.68	7.750	196.85	0.060	1.52	1/4
KF070ARO*RBC	7.0000	177.800	8.5000	215.900	0.7500	19.050	7.563	192.10	7.938	201.63	8.125	206.38	0.080	2.03	3/8
KG070ARO*RBC	7.0000	177.800	9.0000	228.600	1.0000	25.400	7.750	196.85	8.250	209.55	8.500	215.90	0.080	2.03	1/2
KA075ARO*RBC	7.5000	190.500	8.0000	203.200	0.2500	6.350	7.688	195.28	7.813	198.45	7.875	200.03	0.025	0.64	1/8
KB075ARO*RBC	7.5000	190.500	8.1250	206.375	0.3125	7.938	7.734	196.44	7.891	200.43	7.969	202.41	0.032	0.81	5/32
KC075ARO*RBC	7.5000	190.500	8.2500	209.550	0.3750	9.525	7.781	197.64	7.969	202.41	8.063	204.80	0.040	1.02	3/16
KD075ARO*RBC	7.5000	190.500	8.5000	215.900	0.5000	12.700	7.875	200.03	8.125	206.38	8.250	209.55	0.060	1.52	1/4
KF075ARO*RBC	7.5000	190.500	9.0000	228.600	0.7500	19.050	8.063	204.80	8.438	214.33	8.625	219.08	0.080	2.03	3/8
KG075ARO*RBC	7.5000	190.500	9.5000	241.300	1.0000	25.400	8.250	209.55	8.750	222.25	9.000	228.60	0.080	2.03	1/2
KA080ARO*RBC	8.0000	203.200	8.5000	215.900	0.2500	6.350	8.188	207.98	8.313	211.15	8.375	212.73	0.025	0.64	1/8
KB080ARO*RBC	8.0000	203.200	8.6250	219.075	0.3125	7.938	8.234	209.14	8.391	213.13	8.469	215.11	0.032	0.81	5/32
KC080ARO*RBC	8.0000	203.200	8.7500	222.250	0.3750	9.525	8.281	210.34	8.469	215.11	8.563	217.50	0.040	1.02	3/16
KD080ARO*RBC	8.0000	203.200	9.0000	228.600	0.5000	12.700	8.375	212.73	8.625	219.08	8.750	222.25	0.060	1.52	1/4
KF080ARO*RBC	8.0000	203.200	9.5000	241.300	0.7500	19.050	8.563	217.50	8.938	227.03	9.125	231.78	0.080	2.03	3/8
KG080ARO*RBC	8.0000	203.200	10.0000	254.000	1.0000	25.400	8.750	222.25	9.250	234.95	9.500	241.30	0.080	2.03	1/2
KA090ARO*RBC	9.0000	228.600	9.5000	241.300	0.2500	6.350	9.188	233.38	9.313	236.55	9.375	238.13	0.025	0.64	1/8
KB090ARO*RBC	9.0000	228.600	9.6250	244.475	0.3125	7.938	9.234	234.54	9.391	238.53	9.469	240.51	0.032	0.81	5/32
KC090ARO*RBC	9.0000	228.600	9.7500	247.650	0.3750	9.525	9.281	235.74	9.469	240.51	9.563	242.90	0.040	1.02	3/16
KD090ARO*RBC	9.0000	228.600	10.0000	254.000	0.5000	12.700	9.375	238.13	9.625	244.48	9.750	247.65	0.060	1.52	1/4
KF090ARO*RBC	9.0000	228.600	10.5000	266.700	0.7500	19.050	9.563	242.90	9.938	252.43	10.125	257.18	0.080	2.03	3/8
KG090ARO*RBC	9.0000	228.600	11.0000	279.400	1.0000	25.400	9.750	247.65	10.250	260.35	10.500	266.70	0.080	2.03	1/2
KA100ARO*RBC	10.0000	254.000	10.5000	266.700	0.2500	6.350	10.188	258.78	10.313	261.95	10.375	263.53	0.025	0.64	1/8
KB100ARO*RBC	10.0000	254.000	10.6250	269.875	0.3125	7.938	10.234	259.94	10.391	263.93	10.469	265.91	0.032	0.81	5/32
KC100ARO*RBC	10.0000	254.000	10.7500	273.050	0.3750	9.525	10.281	261.14	10.469	265.91	10.563	268.30	0.040	1.02	3/16
KD100ARO*RBC	10.0000	254.000	11.0000	279.400	0.5000	12.700	10.375	263.53	10.625	269.88	10.750	273.05	0.060	1.52	1/4
KF100ARO*RBC	10.0000	254.000	11.5000	292.100	0.7500	19.050	10.563	268.30	10.938	277.83	11.125	282.58	0.080	2.03	3/8
KG100ARO*RBC	10.0000	254.000	12.0000	304.800	1.0000	25.400	10.750	273.05	11.250	285.75	11.500	292.10	0.080	2.03	1/2

*The alphanumeric identification system is used under license.

© 2008, 2011, 2018 RBC Bearings Incorporated. All rights reserved.

THIN SECTION BALL BEARINGS

THIN SECTION BALL BEARINGS — ANGULAR CONTACT, A-TYPE



- 52100 steel
- Large diameter
- Light weight
- Small cross-section
- Circular pocket ball separator

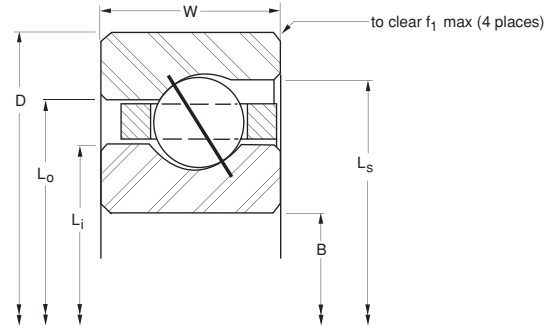

	Ball Quantity	Approx. Weight		LOAD RATINGS										PART NUMBER*		
				Radial				Thrust				Moment				
				Static		Dynamic		Static		Dynamic		Static			Dynamic	
lbs.	kg	lbf	N	lbf	N	lbf	N	lbf	N	lbf - in	Nm	lbf - in	Nm			
	100	0.28	0.127	2,190	9,740	860	3,830	6,320	28,110	2,500	11,120	N/A	N/A	N/A	N/A	KA060AR0*RBC
	85	0.44	0.200	2,990	13,300	1,240	5,520	8,630	38,390	3,600	16,010	N/A	N/A	N/A	N/A	KB060AR0*RBC
	72	0.63	0.286	3,750	16,680	1,620	7,210	10,820	48,130	4,690	20,860	N/A	N/A	N/A	N/A	KC060AR0*RBC
	52	1.16	0.526	5,130	22,820	2,720	12,100	14,820	65,920	7,880	35,050	N/A	N/A	N/A	N/A	KD060AR0*RBC
	37	2.70	1.225	9,040	40,210	5,010	22,290	26,100	116,100	14,530	64,630	N/A	N/A	N/A	N/A	KF060AR0*RBC
	28	5.10	2.313	13,270	59,030	8,860	39,410	38,300	170,370	25,700	114,320	N/A	N/A	N/A	N/A	KG060AR0*RBC
	108	0.30	0.136	2,370	10,540	890	3,960	6,830	30,380	2,580	11,480	N/A	N/A	N/A	N/A	KA065AR0*RBC
	91	0.47	0.213	3,200	14,230	1,260	5,600	9,240	41,100	3,650	16,240	N/A	N/A	N/A	N/A	KB065AR0*RBC
	78	0.68	0.308	4,060	18,060	1,670	7,430	11,720	52,130	4,830	21,480	N/A	N/A	N/A	N/A	KC065AR0*RBC
	56	1.22	0.553	5,530	24,600	2,780	12,370	15,960	70,990	8,070	35,900	N/A	N/A	N/A	N/A	KD065AR0*RBC
	40	2.90	1.315	9,770	43,460	5,140	22,860	28,220	125,530	14,920	66,370	N/A	N/A	N/A	N/A	KF065AR0*RBC
	30	5.40	2.449	14,220	63,250	9,110	40,520	41,040	182,560	26,410	117,480	N/A	N/A	N/A	N/A	KG065AR0*RBC
	116	0.31	0.141	2,540	11,300	900	4,000	7,340	32,650	2,600	11,570	N/A	N/A	N/A	N/A	KA070AR0*RBC
	98	0.50	0.227	3,450	15,350	1,300	5,780	9,960	44,300	3,760	16,730	N/A	N/A	N/A	N/A	KB070AR0*RBC
	83	0.73	0.331	4,320	19,220	1,720	7,650	12,470	55,470	4,980	22,150	N/A	N/A	N/A	N/A	KC070AR0*RBC
	60	1.31	0.594	5,920	26,330	2,850	12,680	17,100	76,060	8,260	36,740	N/A	N/A	N/A	N/A	KD070AR0*RBC
	43	3.20	1.451	10,510	46,750	5,290	23,530	30,330	134,910	15,350	68,280	N/A	N/A	N/A	N/A	KF070AR0*RBC
	32	5.80	2.631	15,160	67,440	9,370	41,680	43,780	194,740	27,160	120,810	N/A	N/A	N/A	N/A	KG070AR0*RBC
	124	0.34	0.154	2,720	12,100	920	4,090	7,840	34,870	2,660	11,830	N/A	N/A	N/A	N/A	KA075AR0*RBC
	105	0.53	0.240	3,700	16,460	1,330	5,920	10,670	47,460	3,860	17,170	N/A	N/A	N/A	N/A	KB075AR0*RBC
	89	0.78	0.354	4,630	20,600	1,750	7,780	13,380	59,520	5,090	22,640	N/A	N/A	N/A	N/A	KC075AR0*RBC
	64	1.41	0.640	6,320	28,110	2,940	13,080	18,240	81,140	8,520	37,900	N/A	N/A	N/A	N/A	KD075AR0*RBC
	45	3.40	1.542	11,000	48,930	5,380	23,930	31,740	141,190	15,590	69,350	N/A	N/A	N/A	N/A	KF075AR0*RBC
	34	6.10	2.767	16,110	71,660	9,560	42,530	46,510	206,890	27,710	123,260	N/A	N/A	N/A	N/A	KG075AR0*RBC
	132	0.38	0.172	2,890	12,860	960	4,270	8,350	37,140	2,770	12,320	N/A	N/A	N/A	N/A	KA080AR0*RBC
	112	0.57	0.259	3,940	17,530	1,360	6,050	11,380	50,620	3,950	17,570	N/A	N/A	N/A	N/A	KB080AR0*RBC
	95	0.84	0.381	4,950	22,020	1,800	8,010	14,280	63,520	5,210	23,180	N/A	N/A	N/A	N/A	KC080AR0*RBC
	68	1.53	0.694	6,710	29,850	2,990	13,300	19,380	86,210	8,670	38,570	N/A	N/A	N/A	N/A	KD080AR0*RBC
	48	3.50	1.588	11,730	52,180	5,520	24,550	33,860	150,620	16,020	71,260	N/A	N/A	N/A	N/A	KF080AR0*RBC
	36	6.50	2.948	17,060	75,890	9,800	43,590	49,250	219,070	28,430	126,460	N/A	N/A	N/A	N/A	KG080AR0*RBC
	148	0.44	0.200	3,240	14,410	990	4,400	9,360	41,640	2,860	12,720	N/A	N/A	N/A	N/A	KA090AR0*RBC
	125	0.66	0.299	4,400	19,570	1,410	6,270	12,700	56,490	4,080	18,150	N/A	N/A	N/A	N/A	KB090AR0*RBC
	106	0.94	0.426	5,520	24,550	1,860	8,270	15,930	70,860	5,400	24,020	N/A	N/A	N/A	N/A	KC090AR0*RBC
	76	1.72	0.780	7,500	33,360	3,100	13,790	21,660	96,350	9,000	40,030	N/A	N/A	N/A	N/A	KD090AR0*RBC
	54	3.90	1.769	13,190	58,670	5,780	25,710	38,090	169,430	16,760	74,550	N/A	N/A	N/A	N/A	KF090AR0*RBC
	40	7.20	3.266	18,960	84,340	10,190	45,330	54,720	243,410	29,540	131,400	N/A	N/A	N/A	N/A	KG090AR0*RBC
	164	0.50	0.227	3,590	15,970	1,030	4,580	10,370	46,130	3,000	13,340	N/A	N/A	N/A	N/A	KA100AR0*RBC
	139	0.73	0.331	4,890	21,750	1,480	6,580	14,120	62,810	4,290	19,080	N/A	N/A	N/A	N/A	KB100AR0*RBC
	118	1.06	0.481	6,140	27,310	1,942	8,640	17,730	78,870	5,570	24,780	N/A	N/A	N/A	N/A	KC100AR0*RBC
	84	1.88	0.853	8,290	36,880	3,240	14,410	23,940	106,490	9,390	41,770	N/A	N/A	N/A	N/A	KD100AR0*RBC
	59	4.30	1.950	14,420	64,140	5,980	26,600	41,620	185,130	17,330	77,090	N/A	N/A	N/A	N/A	KF100AR0*RBC
	44	7.90	3.583	20,850	92,750	10,560	46,970	60,190	267,740	30,620	136,200	N/A	N/A	N/A	N/A	KG100AR0*RBC

Refer to the Engineering section for load and speed limitations.

© 2008, 2011, 2018 RBC Bearings Incorporated. All rights reserved.

THIN SECTION BALL BEARINGS

THIN SECTION BALL BEARINGS — ANGULAR CONTACT, A-TYPE



ANGULAR CONTACT, A-TYPE

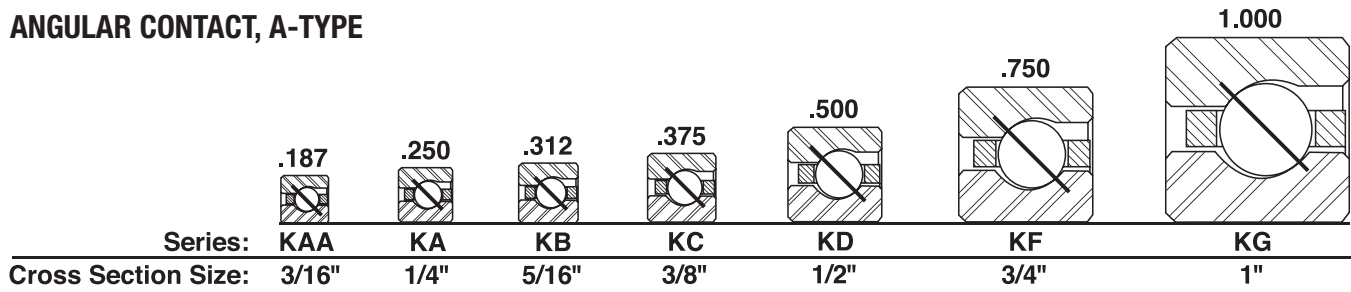

PART NUMBER*	NOMINAL DIMENSIONS														
	B Bore		D Outside Diameter		W Width		Land Diameter			f ₁ Housing Fillet		Ball Diameter			
	in.	mm	in.	mm	in.	mm	L _i -Inner Ring	L _o -Outer Ring	L _s -Counter Bore	in.	mm				
KA110ARO*RBC	11.0000	279.400	11.5000	292.100	0.2500	6.350	11.188	284.18	11.313	287.35	11.375	288.93	0.025	0.64	1/8
KB110ARO*RBC	11.0000	279.400	11.6250	295.275	0.3125	7.938	11.234	285.34	11.391	289.33	11.469	291.31	0.032	0.81	5/32
KC110ARO*RBC	11.0000	279.400	11.7500	298.450	0.3750	9.525	11.281	286.54	11.469	291.31	11.563	293.70	0.040	1.02	3/16
KD110ARO*RBC	11.0000	279.400	12.0000	304.800	0.5000	12.700	11.375	288.93	11.625	295.28	11.750	298.45	0.060	1.52	1/4
KF110ARO*RBC	11.0000	279.400	12.5000	317.500	0.7500	19.050	11.563	293.70	11.938	303.23	12.125	307.98	0.080	2.03	3/8
KG110ARO*RBC	11.0000	279.400	13.0000	330.200	1.0000	25.400	11.750	298.45	12.250	311.15	12.500	317.50	0.080	2.03	1/2
KA120ARO*RBC	12.0000	304.800	12.5000	317.500	0.2500	6.350	12.188	309.58	12.313	312.75	12.375	314.33	0.025	0.64	1/8
KB120ARO*RBC	12.0000	304.800	12.6250	320.675	0.3125	7.938	12.234	310.74	12.391	314.73	12.469	316.71	0.032	0.81	5/32
KC120ARO*RBC	12.0000	304.800	12.7500	323.850	0.3750	9.525	12.281	311.94	12.469	316.71	12.563	319.10	0.040	1.02	3/16
KD120ARO*RBC	12.0000	304.800	13.0000	330.200	0.5000	12.700	12.375	314.33	12.625	320.68	12.750	323.85	0.060	1.52	1/4
KF120ARO*RBC	12.0000	304.800	13.5000	342.900	0.7500	19.050	12.563	319.10	12.938	328.63	13.125	333.38	0.080	2.03	3/8
KG120ARO*RBC	12.0000	304.800	14.0000	355.600	1.0000	25.400	12.750	323.85	13.250	336.55	13.500	342.90	0.080	2.03	1/2
KA140ARO*RBC	14.0000	355.600	14.6250	371.475	0.3125	7.938	14.234	361.54	14.391	365.53	14.469	367.51	0.032	0.81	5/32
KC140ARO*RBC	14.0000	355.600	14.7500	374.650	0.3750	9.525	14.281	362.74	14.469	367.51	14.563	369.90	0.040	1.02	3/16
KD140ARO*RBC	14.0000	355.600	15.0000	381.000	0.5000	12.700	14.375	365.13	14.625	371.48	14.750	374.65	0.060	1.52	1/4
KF140ARO*RBC	14.0000	355.600	15.5000	393.700	0.7500	19.050	14.563	369.90	14.938	379.43	15.125	384.18	0.080	2.03	3/8
KG140ARO*RBC	14.0000	355.600	16.0000	406.400	1.0000	25.400	14.750	374.65	15.250	387.35	15.500	393.70	0.080	2.03	1/2
KB160ARO*RBC	16.0000	406.400	16.6250	422.275	0.3125	7.938	16.234	412.34	16.391	416.33	16.469	418.31	0.032	0.81	5/32
KC160ARO*RBC	16.0000	406.400	16.7500	425.450	0.3750	9.525	16.281	413.54	16.469	418.31	16.563	420.70	0.040	1.02	3/16
KD160ARO*RBC	16.0000	406.400	17.0000	431.800	0.5000	12.700	16.375	415.93	16.625	422.28	16.750	425.45	0.060	1.52	1/4
KF160ARO*RBC	16.0000	406.400	17.5000	444.500	0.7500	19.050	16.563	420.70	16.938	430.23	17.125	434.98	0.080	2.03	3/8
KG160ARO*RBC	16.0000	406.400	18.0000	457.200	1.0000	25.400	16.750	425.45	17.250	438.15	17.500	444.50	0.080	2.03	1/2
KB180ARO*RBC	18.0000	457.200	18.6250	473.075	0.3125	7.938	18.234	463.14	18.391	467.13	18.469	469.11	0.032	0.81	5/32
KC180ARO*RBC	18.0000	457.200	18.7500	476.250	0.3750	9.525	18.281	464.34	18.469	469.11	18.563	471.50	0.040	1.02	3/16
KD180ARO*RBC	18.0000	457.200	19.0000	482.600	0.5000	12.700	18.375	466.73	18.625	473.08	18.750	476.25	0.060	1.52	1/4
KF180ARO*RBC	18.0000	457.200	19.5000	495.300	0.7500	19.050	18.563	471.50	18.938	481.03	19.125	485.78	0.080	2.03	3/8
KG180ARO*RBC	18.0000	457.200	20.0000	508.000	1.0000	25.400	18.750	476.25	19.250	488.95	19.500	495.30	0.080	2.03	1/2
KB200ARO*RBC	20.0000	508.000	20.6250	523.875	0.3125	7.938	20.234	513.94	20.391	517.93	20.469	519.91	0.032	0.81	5/32
KC200ARO*RBC	20.0000	508.000	20.7500	527.050	0.3750	9.525	20.281	515.14	20.469	519.91	20.563	522.30	0.040	1.02	3/16
KD200ARO*RBC	20.0000	508.000	21.0000	533.400	0.5000	12.700	20.375	517.53	20.625	523.88	20.750	527.05	0.060	1.52	1/4
KF200ARO*RBC	20.0000	508.000	21.5000	546.100	0.7500	19.050	20.563	522.30	20.938	531.83	21.125	536.58	0.080	2.03	3/8
KG200ARO*RBC	20.0000	508.000	22.0000	558.800	1.0000	25.400	20.750	527.05	21.250	539.75	21.500	546.10	0.080	2.03	1/2
KB250ARO*RBC	25.0000	635.000	25.7500	654.050	0.3750	9.525	25.281	642.14	25.469	646.91	25.563	649.30	0.040	1.02	3/16
KD250ARO*RBC	25.0000	635.000	26.0000	660.400	0.5000	12.700	25.375	644.53	25.625	650.88	25.750	654.05	0.060	1.52	1/4
KF250ARO*RBC	25.0000	635.000	26.5000	673.100	0.7500	19.050	25.563	649.30	25.938	658.83	26.125	663.58	0.080	2.03	3/8
KG250ARO*RBC	25.0000	635.000	27.0000	685.800	1.0000	25.400	25.750	654.05	26.250	666.75	26.500	673.10	0.080	2.03	1/2
KC300ARO*RBC	30.0000	762.000	30.7500	781.050	0.3750	9.525	30.281	769.14	30.469	773.91	30.563	776.30	0.040	1.02	3/16
KD300ARO*RBC	30.0000	762.000	31.0000	787.400	0.5000	12.700	30.375	771.53	30.625	777.88	30.750	781.05	0.060	1.52	1/4
KF300ARO*RBC	30.0000	762.000	31.5000	800.100	0.7500	19.050	30.563	776.30	30.938	785.83	31.125	790.58	0.080	2.03	3/8
KG300ARO*RBC	30.0000	762.000	32.0000	812.800	1.0000	25.400	30.750	781.05	31.250	793.75	31.500	800.10	0.080	2.03	1/2
KF350ARO*RBC	35.0000	889.000	36.5000	927.100	0.7500	19.050	35.563	903.30	35.938	912.83	36.125	917.58	0.080	2.03	3/8
KG350ARO*RBC	35.0000	889.000	37.0000	939.800	1.0000	25.400	35.750	908.05	36.250	920.75	36.500	927.10	0.080	2.03	1/2
KF400ARO*RBC	40.0000	1016.000	41.5000	1054.100	0.7500	19.050	40.563	1030.30	40.938	1039.83	41.125	1044.58	0.080	2.03	3/8
KG400ARO*RBC	40.0000	1016.000	42.0000	1066.800	1.0000	25.400	40.750	1035.05	41.250	1047.75	41.500	1054.10	0.080	2.03	1/2

*The alphanumeric identification system is used under license.

© 2008, 2011, 2018 RBC Bearings Incorporated. All rights reserved.

THIN SECTION BALL BEARINGS

THIN SECTION BALL BEARINGS — ANGULAR CONTACT, A-TYPE



- 52100 steel
- Large diameter
- Light weight
- Small cross-section
- Circular pocket ball separator

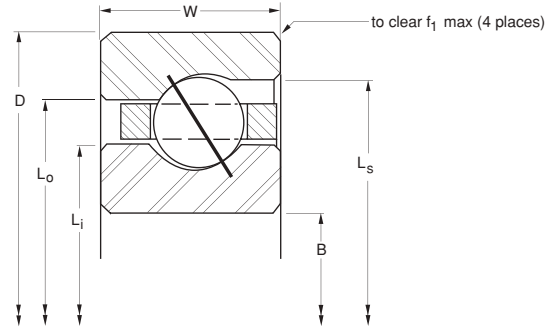

	Ball Quantity	Approx. Weight		LOAD RATINGS										PART NUMBER*		
				Radial				Thrust				Moment				
				Static		Dynamic		Static		Dynamic		Static	Dynamic			
lbs.	kg	lbf	N	lbf	N	lbf	N	lbf	Nm	lbf	Nm					
	180	0.52	0.236	3,940	17,530	1,072	4,770	11,380	50,620	3,100	13,790	N/A	N/A	N/A	N/A	KA110ARO*RBC
	152	0.75	0.340	5,350	23,800	1,540	6,850	15,440	68,680	4,350	19,350	N/A	N/A	N/A	N/A	KB110ARO*RBC
	129	1.16	0.526	6,720	29,890	2,047	9,110	19,390	86,250	5,780	25,710	N/A	N/A	N/A	N/A	KC110ARO*RBC
	92	2.06	0.934	9,080	40,390	3,310	14,720	26,220	116,630	9,600	42,700	N/A	N/A	N/A	N/A	KD110ARO*RBC
	65	4.80	2.177	15,880	70,640	6,227	27,700	45,850	203,950	17,870	79,490	N/A	N/A	N/A	N/A	KF110ARO*RBC
	48	8.60	3.901	22,750	101,200	10,920	48,570	65,660	292,070	31,660	140,830	N/A	N/A	N/A	N/A	KG110ARO*RBC
	196	0.56	0.254	4,290	19,080	1,128	5,020	12,390	55,110	3,200	14,230	N/A	N/A	N/A	N/A	KA120ARO*RBC
	166	0.83	0.376	5,840	25,980	1,623	7,220	16,860	75,000	4,510	20,060	N/A	N/A	N/A	N/A	KB120ARO*RBC
	140	1.25	0.567	7,290	32,430	2,147	9,550	21,040	93,590	5,980	26,600	N/A	N/A	N/A	N/A	KC120ARO*RBC
	100	2.25	1.021	9,870	43,900	3,430	15,260	28,500	126,770	9,950	44,260	N/A	N/A	N/A	N/A	KD120ARO*RBC
	70	5.20	2.359	17,100	76,060	6,487	28,860	49,380	219,650	18,340	81,580	N/A	N/A	N/A	N/A	KF120ARO*RBC
	52	9.30	4.218	24,640	109,600	11,230	49,950	71,140	316,450	32,570	144,880	N/A	N/A	N/A	N/A	KG120ARO*RBC
	192	1.05	0.476	6,760	30,070	1,767	7,860	19,500	86,740	4,840	21,530	N/A	N/A	N/A	N/A	KA140ARO*RBC
	163	1.52	0.689	8,490	37,770	2,347	10,440	24,500	108,980	6,330	28,160	N/A	N/A	N/A	N/A	KB140ARO*RBC
	116	2.73	1.238	11,450	50,930	3,582	15,930	33,060	147,060	10,340	45,990	N/A	N/A	N/A	N/A	KD140ARO*RBC
	81	6.00	2.722	19,790	88,030	7,043	31,330	57,140	254,170	19,490	86,700	N/A	N/A	N/A	N/A	KF140ARO*RBC
	60	10.80	4.899	28,430	126,460	11,770	52,360	82,080	365,110	34,150	151,910	N/A	N/A	N/A	N/A	KG140ARO*RBC
	219	1.20	0.544	7,710	34,300	1,907	8,480	22,250	98,970	5,150	22,910	N/A	N/A	N/A	N/A	KB160ARO*RBC
	186	1.73	0.785	9,680	43,060	2,533	11,270	27,950	124,330	6,730	29,940	N/A	N/A	N/A	N/A	KC160ARO*RBC
	132	3.10	1.406	13,030	57,960	3,856	17,150	37,620	167,340	11,030	49,060	N/A	N/A	N/A	N/A	KD160ARO*RBC
	92	7.10	3.221	22,480	100,000	7,563	33,640	64,890	288,650	20,310	90,340	N/A	N/A	N/A	N/A	KF160ARO*RBC
	68	12.30	5.579	32,220	143,320	12,360	54,980	93,020	413,770	35,850	159,470	N/A	N/A	N/A	N/A	KG160ARO*RBC
	246	1.35	0.612	8,660	38,520	2,038	9,070	24,990	111,160	5,510	24,510	N/A	N/A	N/A	N/A	KB180ARO*RBC
	209	1.94	0.880	10,880	48,400	2,707	12,040	31,410	139,720	7,280	32,380	N/A	N/A	N/A	N/A	KC180ARO*RBC
	148	3.48	1.579	14,610	64,990	4,113	18,300	42,180	187,630	11,390	50,670	N/A	N/A	N/A	N/A	KD180ARO*RBC
	104	7.90	3.583	25,410	113,030	8,103	36,040	73,360	326,320	21,210	94,350	N/A	N/A	N/A	N/A	KF180ARO*RBC
	76	13.70	6.214	36,020	160,220	12,898	57,370	104,000	462,620	37,230	165,610	N/A	N/A	N/A	N/A	KG180ARO*RBC
	273	1.50	0.680	9,610	42,750	2,162	9,620	27,730	123,350	5,900	26,240	N/A	N/A	N/A	N/A	KB200ARO*RBC
	231	2.16	0.980	12,030	53,510	2,863	12,740	34,720	154,440	7,780	34,610	N/A	N/A	N/A	N/A	KC200ARO*RBC
	164	3.85	1.746	16,190	72,020	4,356	19,380	46,740	207,910	11,920	53,020	N/A	N/A	N/A	N/A	KD200ARO*RBC
	115	8.90	4.037	28,100	125,000	8,562	38,090	81,120	360,840	22,680	100,890	N/A	N/A	N/A	N/A	KF200ARO*RBC
	84	15.80	7.167	39,810	177,080	13,612	60,550	114,900	511,100	38,830	172,720	N/A	N/A	N/A	N/A	KG200ARO*RBC
	288	2.69	1.220	14,900	66,280	3,233	14,380	43,280	192,520	9,010	40,080	N/A	N/A	N/A	N/A	KC250ARO*RBC
	204	4.79	2.173	20,140	89,590	4,908	21,830	58,140	258,620	13,540	60,230	N/A	N/A	N/A	N/A	KD250ARO*RBC
	142	10.90	4.944	34,700	154,350	9,585	42,640	100,200	445,710	26,100	116,100	N/A	N/A	N/A	N/A	KF250ARO*RBC
	104	19.50	8.845	49,280	219,210	15,239	67,790	142,300	632,980	41,420	184,250	N/A	N/A	N/A	N/A	KG250ARO*RBC
	345	3.21	1.456	17,960	79,890	3,561	15,840	51,850	230,640	10,160	45,190	N/A	N/A	N/A	N/A	KC300ARO*RBC
	244	5.73	2.599	24,090	107,160	5,397	24,010	69,540	309,330	15,260	67,880	N/A	N/A	N/A	N/A	KD300ARO*RBC
	170	13.00	5.897	41,540	184,780	10,533	46,850	119,900	533,340	29,430	130,910	N/A	N/A	N/A	N/A	KF300ARO*RBC
	124	23.30	10.569	58,760	261,380	16,687	74,230	169,600	754,420	46,020	204,710	N/A	N/A	N/A	N/A	KG300ARO*RBC
	198	15.10	6.849	48,380	215,200	11,382	50,630	139,700	621,420	32,580	144,920	N/A	N/A	N/A	N/A	KF350ARO*RBC
	144	27.10	12.292	68,240	303,550	17,982	79,990	197,000	876,300	50,840	226,150	N/A	N/A	N/A	N/A	KG350ARO*RBC
	226	17.20	7.802	55,220	245,630	12,147	54,030	159,400	709,050	35,580	158,270	N/A	N/A	N/A	N/A	KF400ARO*RBC
	164	30.80	13.971	77,720	345,720	19,153	85,200	224,400	998,180	55,440	246,610	N/A	N/A	N/A	N/A	KG400ARO*RBC

Refer to the Engineering section for load and speed limitations.

© 2008, 2011, 2018 RBC Bearings Incorporated. All rights reserved.

THIN SECTION BALL BEARINGS

THIN SECTION BALL BEARINGS — 4-POINT CONTACT, X-TYPE



4-POINT CONTACT, X-TYPE

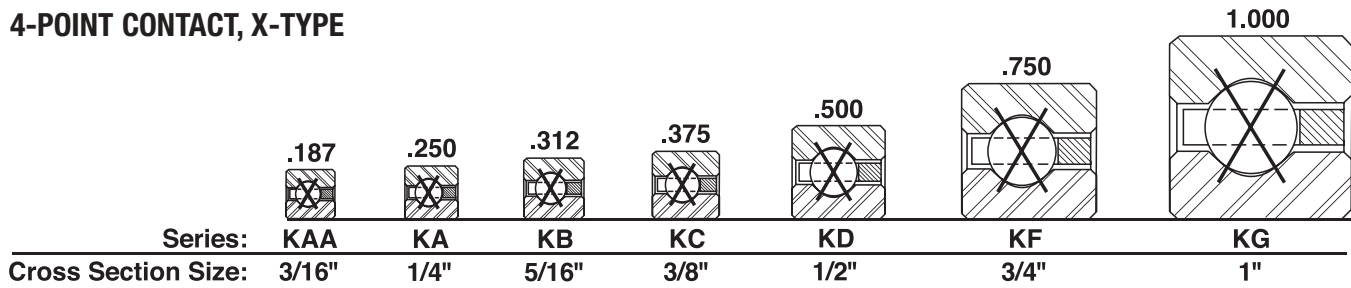

PART NUMBER*	NOMINAL DIMENSIONS												
	B Bore		D Outside Diameter		W Width		Land Diameter				f ₁ Housing Fillet		Ball Diameter
	in.	mm	in.	mm	in.	mm	L _i -Inner Ring		L _o -Outer Ring		in.	mm	in.
KAA10XLO*RBC	1.0000	25.400	1.3750	34.925	0.1875	4.763	1.141	28.98	1.234	31.34	0.015	0.38	3/32
KAA15XLO*RBC	1.5000	38.100	1.8750	47.625	0.1875	4.763	1.641	41.68	1.734	44.04	0.015	0.38	3/32
KA020XP0*RBC	2.0000	50.800	2.5000	63.500	0.2500	6.350	2.188	55.58	2.313	58.75	0.025	0.64	1/8
KB020XP0*RBC	2.0000	50.800	2.6250	66.675	0.3125	7.938	2.234	56.74	2.391	60.73	0.032	0.81	5/32
KA025XP0*RBC	2.5000	63.500	3.0000	76.200	0.2500	6.350	2.688	68.28	2.813	71.45	0.025	0.64	1/8
KB025XP0*RBC	2.5000	63.500	3.1250	79.375	0.3125	7.938	2.734	69.44	2.891	73.43	0.040	1.02	5/32
KA030XP0*RBC	3.0000	76.200	3.5000	88.900	0.2500	6.350	3.188	80.98	3.313	84.15	0.025	0.64	1/8
KB030XP0*RBC	3.0000	76.200	3.6250	92.075	0.3125	7.938	3.234	82.14	3.391	86.13	0.032	0.81	5/32
KA035XP0*RBC	3.5000	88.900	4.0000	101.600	0.2500	6.350	3.688	93.68	3.813	96.85	0.025	0.64	1/8
KB035XP0*RBC	3.5000	88.900	4.1250	104.775	0.3125	7.938	3.734	94.84	3.891	98.83	0.032	0.81	5/32
KA040XP0*RBC	4.0000	101.600	4.5000	114.300	0.2500	6.350	4.188	106.38	4.313	109.55	0.025	0.64	1/8
KB040XP0*RBC	4.0000	101.600	4.6250	117.475	0.3125	7.938	4.234	107.54	4.391	111.53	0.032	0.81	5/32
KC040XP0*RBC	4.0000	101.600	4.7500	120.650	0.3750	9.525	4.281	108.74	4.469	113.51	0.040	1.02	3/16
KD040XP0*RBC	4.0000	101.600	5.0000	127.000	0.5000	12.700	4.375	111.13	4.625	117.48	0.060	1.52	1/4
KF040XP0*RBC	4.0000	101.600	5.5000	139.700	0.7500	19.050	4.563	115.90	4.938	125.43	0.080	2.03	3/8
KG040XP0*RBC	4.0000	101.600	6.0000	152.400	1.0000	25.400	4.750	120.65	5.250	133.35	0.080	2.03	1/2
KA042XP0*RBC	4.2500	107.950	4.7500	120.650	0.2500	6.350	4.438	112.73	4.563	115.90	0.025	0.64	1/8
KB042XP0*RBC	4.2500	107.950	4.8750	123.825	0.3125	7.938	4.484	113.89	4.641	117.88	0.032	0.81	5/32
KC042XP0*RBC	4.2500	107.950	5.0000	127.000	0.3750	9.525	4.531	115.09	4.719	119.86	0.040	1.02	3/16
KD042XP0*RBC	4.2500	107.950	5.2500	133.350	0.5000	12.700	4.625	117.48	4.875	123.83	0.060	1.52	1/4
KF042XP0*RBC	4.2500	107.950	5.7500	146.050	0.7500	19.050	4.813	122.25	5.188	131.78	0.080	2.03	3/8
KG042XP0*RBC	4.2500	107.950	6.2500	158.750	1.0000	25.400	5.000	127.00	5.500	139.70	0.080	2.03	1/2
KA045XP0*RBC	4.5000	114.300	5.0000	127.000	0.2500	6.350	4.688	119.08	4.813	122.25	0.025	0.64	1/8
KB045XP0*RBC	4.5000	114.300	5.1250	130.175	0.3125	7.938	4.734	120.24	4.891	124.23	0.032	0.81	5/32
KC045XP0*RBC	4.5000	114.300	5.2500	133.350	0.3750	9.525	4.781	121.44	4.969	126.21	0.040	1.02	3/16
KD045XP0*RBC	4.5000	114.300	5.5000	139.700	0.5000	12.700	4.875	123.83	5.125	130.18	0.060	1.52	1/4
KF045XP0*RBC	4.5000	114.300	6.0000	152.400	0.7500	19.050	5.063	128.60	5.438	138.13	0.080	2.03	3/8
KG045XP0*RBC	4.5000	114.300	6.5000	165.100	1.0000	25.400	5.250	133.35	5.750	146.05	0.080	2.03	1/2
KA047XP0*RBC	4.7500	120.650	5.2500	133.350	0.2500	6.350	4.938	125.43	5.063	128.60	0.025	0.64	1/8
KB047XP0*RBC	4.7500	120.650	5.3750	136.525	0.3125	7.938	4.984	126.59	5.141	130.58	0.032	0.81	5/32
KC047XP0*RBC	4.7500	120.650	5.5000	139.700	0.3750	9.525	5.031	127.79	5.219	132.56	0.040	1.02	3/16
KD047XP0*RBC	4.7500	120.650	5.7500	146.050	0.5000	12.700	5.125	130.18	5.375	136.53	0.060	1.52	1/4
KF047XP0*RBC	4.7500	120.650	6.2500	158.750	0.7500	19.050	5.313	134.95	5.688	144.48	0.080	2.03	3/8
KG047XP0*RBC	4.7500	120.650	6.7500	171.450	1.0000	25.400	5.500	139.70	6.000	152.40	0.080	2.03	1/2
KA050XP0*RBC	5.0000	127.000	5.5000	139.700	0.2500	6.350	5.188	131.78	5.313	134.95	0.025	0.64	1/8
KB050XP0*RBC	5.0000	127.000	5.6250	142.875	0.3125	7.938	5.234	132.94	5.391	136.93	0.032	0.81	5/32
KC050XP0*RBC	5.0000	127.000	5.7500	146.050	0.3750	9.525	5.281	134.14	5.469	138.91	0.040	1.02	3/16
KD050XP0*RBC	5.0000	127.000	6.0000	152.400	0.5000	12.700	5.375	136.53	5.625	142.88	0.060	1.52	1/4
KF050XP0*RBC	5.0000	127.000	6.5000	165.100	0.7500	19.050	5.563	141.30	5.938	150.83	0.080	2.03	3/8
KG050XP0*RBC	5.0000	127.000	7.0000	177.800	1.0000	25.400	5.750	146.05	6.250	158.75	0.080	2.03	1/2
KA055XP0*RBC	5.5000	139.700	6.0000	152.400	0.2500	6.350	5.688	144.48	5.813	147.65	0.025	0.64	1/8
KB055XP0*RBC	5.5000	139.700	6.1250	155.575	0.3125	7.938	5.734	145.64	5.891	149.63	0.032	0.81	5/32
KC055XP0*RBC	5.5000	139.700	6.2500	158.750	0.3750	9.525	5.781	146.84	5.969	151.61	0.040	1.02	3/16
KD055XP0*RBC	5.5000	139.700	6.5000	165.100	0.5000	12.700	5.875	149.23	6.125	155.58	0.060	1.52	1/4
KF055XP0*RBC	5.5000	139.700	7.0000	177.800	0.7500	19.050	6.063	154.00	6.438	163.53	0.080	2.03	3/8
KG055XP0*RBC	5.5000	139.700	7.5000	190.500	1.0000	25.400	6.250	158.75	6.750	171.45	0.080	2.03	1/2

*The alphanumeric identification system is used under license.

© 2008, 2011, 2018 RBC Bearings Incorporated. All rights reserved.

THIN SECTION BALL BEARINGS

THIN SECTION BALL BEARINGS — 4-POINT CONTACT, X-TYPE



- 52100 steel
- Large diameter
- Light weight
- Small cross-section
- Snap-over ball separator

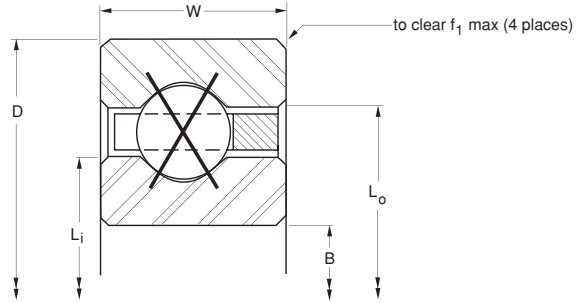

Ball Quantity	Approx. Weight lbs. kg	LOAD RATINGS										PART NUMBER*		
		Radial				Thrust				Moment				
		Static		Dynamic		Static		Dynamic		Static			Dynamic	
lbf	N	lbf	N	lbf	N	lbf	N	lbf - in	Nm	lbf - in	Nm			
21	0.03 0.014	290	1,290	270	1,200	730	3,250	680	3,020	170	20	160	20	KAA10XL0*RBC
29	0.04 0.018	400	1,780	310	1,380	1,000	4,450	770	3,430	340	40	260	30	KAA15XL0*RBC
27	0.10 0.045	680	3,020	514	2,290	1,710	7,610	1,230	5,470	770	90	550	60	KA020XP0*RBC
23	0.16 0.073	930	4,140	758	3,370	2,340	10,410	1,740	7,740	1,080	120	800	90	KB020XP0*RBC
33	0.13 0.059	830	3,690	583	2,590	2,090	9,300	1,320	5,870	1,150	130	730	80	KA025XP0*RBC
28	0.20 0.091	1,140	5,070	848	3,770	2,840	12,630	1,880	8,360	1,600	180	1,060	120	KB025XP0*RBC
39	0.15 0.068	990	4,400	643	2,860	2,470	10,990	1,410	6,270	1,600	180	920	100	KA030XP0*RBC
33	0.24 0.109	1,340	5,960	933	4,150	3,350	14,900	1,990	8,850	2,220	250	1,320	150	KB030XP0*RBC
45	0.18 0.082	1,140	5,070	701	3,120	2,850	12,680	1,480	6,580	2,130	240	1,110	130	KA035XP0*RBC
38	0.27 0.122	1,540	6,850	1,014	4,510	3,860	17,170	2,100	9,340	2,940	330	1,600	180	KB035XP0*RBC
51	0.19 0.086	1,290	5,740	756	3,360	3,220	14,320	1,550	6,890	2,740	310	1,320	150	KA040XP0*RBC
43	0.30 0.136	1,750	7,780	1,091	4,850	4,370	19,440	2,210	9,830	3,770	430	1,900	210	KB040XP0*RBC
35	0.45 0.204	2,100	9,340	1,417	6,300	5,260	23,400	2,810	12,500	4,600	520	2,460	280	KC040XP0*RBC
27	0.78 0.354	3,080	13,700	2,311	10,280	7,700	34,250	4,890	21,750	6,930	780	4,400	500	KD040XP0*RBC
19	1.90 0.862	5,360	23,840	4,665	20,750	13,400	59,610	8,830	39,280	12,730	1,440	8,390	950	KF040XP0*RBC
15	3.60 1.633	8,210	36,520	7,979	35,490	20,520	91,280	15,150	67,390	20,520	2,320	15,150	1,710	KG040XP0*RBC
54	0.20 0.091	1,370	6,090	783	3,480	3,410	15,170	1,590	7,070	3,070	350	1,430	160	KA042XP0*RBC
45	0.31 0.141	1,830	8,140	1,120	4,980	4,570	20,330	2,230	9,920	4,170	470	2,040	230	KB042XP0*RBC
37	0.47 0.213	2,220	9,880	1,464	6,510	5,560	24,730	2,870	12,770	5,140	580	2,650	300	KC042XP0*RBC
28	0.83 0.376	3,190	14,190	2,355	10,480	7,980	35,500	4,920	21,890	7,580	860	4,670	530	KD042XP0*RBC
20	2.00 0.907	5,640	25,090	4,795	21,330	14,110	62,760	8,990	39,990	14,110	1,590	8,993	1,020	KF042XP0*RBC
15	3.80 1.724	8,210	36,520	7,917	35,220	20,520	91,280	15,150	67,390	21,550	2,430	15,910	1,800	KG042XP0*RBC
57	0.22 0.100	1,440	6,410	809	3,600	3,600	16,010	1,610	7,160	3,420	390	1,530	170	KA045XP0*RBC
48	0.33 0.150	1,950	8,670	1,165	5,180	4,880	21,710	2,300	10,230	4,690	530	2,220	250	KB045XP0*RBC
39	0.48 0.218	2,340	10,410	1,510	6,720	5,860	26,070	2,920	12,990	5,710	650	2,850	320	KC045XP0*RBC
30	0.88 0.399	3,420	15,210	2,454	10,920	8,550	38,030	5,080	22,600	8,550	970	5,080	570	KD045XP0*RBC
21	2.10 0.953	5,930	26,380	4,923	21,900	14,810	65,880	9,180	40,830	15,550	1,760	9,695	1,100	KF045XP0*RBC
16	4.00 1.814	8,760	38,970	8,205	36,500	21,890	97,370	15,820	70,370	24,080	2,720	17,400	1,970	KG045XP0*RBC
60	0.23 0.104	1,520	6,760	834	3,710	3,790	16,860	1,650	7,340	3,790	430	1,650	190	KA047XP0*RBC
50	0.34 0.154	2,030	9,030	1,193	5,310	5,080	22,600	2,310	10,280	5,140	580	2,340	260	KB047XP0*RBC
41	0.50 0.227	2,460	10,940	1,556	6,920	6,160	27,400	2,970	13,210	6,320	710	3,040	340	KC047XP0*RBC
31	0.94 0.426	3,530	15,700	2,496	11,100	8,840	39,320	5,130	22,820	9,280	1,050	5,380	610	KD047XP0*RBC
22	2.20 0.998	6,210	27,620	5,048	22,450	15,520	69,040	9,380	41,720	17,070	1,930	10,416	1,180	KF047XP0*RBC
17	4.10 1.860	9,300	41,370	8,487	37,750	23,260	103,470	16,470	73,260	26,740	3,020	18,940	2,140	KG047XP0*RBC
63	0.24 0.109	1,590	7,070	859	3,820	3,980	17,700	1,680	7,470	4,180	470	1,760	200	KA050XP0*RBC
53	0.38 0.172	2,150	9,560	1,236	5,500	5,380	23,930	2,380	10,590	5,720	650	2,520	280	KB050XP0*RBC
43	0.58 0.263	2,590	11,520	1,600	7,120	6,460	28,740	3,040	13,520	6,950	790	3,270	370	KC050XP0*RBC
33	1.00 0.454	3,760	16,730	2,592	11,530	9,410	41,860	5,270	23,440	10,350	1,170	5,800	660	KD050XP0*RBC
23	2.30 1.043	6,490	28,870	5,172	23,010	16,220	72,150	9,520	42,350	18,660	2,110	11,157	1,260	KF050XP0*RBC
18	4.30 1.950	9,850	43,810	8,762	38,980	24,620	109,520	17,110	76,110	29,550	3,340	20,530	2,320	KG050XP0*RBC
69	0.25 0.113	1,750	7,780	908	4,040	4,360	19,390	1,720	7,650	5,020	570	1,970	220	KA055XP0*RBC
58	0.41 0.186	2,360	10,500	1,304	5,800	5,890	26,200	2,460	10,940	6,850	770	2,860	320	KB055XP0*RBC
47	0.59 0.268	2,830	12,590	1,687	7,500	7,060	31,400	3,120	13,880	8,300	940	3,717	420	KC055XP0*RBC
36	1.06 0.481	4,100	18,240	2,725	12,120	10,260	45,640	5,450	24,240	12,310	1,390	6,540	740	KD055XP0*RBC
25	2.50 1.134	7,050	31,360	5,415	24,090	17,630	78,420	9,820	43,680	22,040	2,490	12,696	1,430	KF055XP0*RBC
19	4.70 2.132	10,400	46,260	8,979	39,940	25,990	115,610	17,460	77,670	33,790	3,820	22,700	2,560	KG055XP0*RBC

Refer to the Engineering section for load and speed limitations.

© 2008, 2011, 2018 RBC Bearings Incorporated. All rights reserved.

THIN SECTION BALL BEARINGS

THIN SECTION BALL BEARINGS — 4-POINT CONTACT, X-TYPE



4-POINT CONTACT, X-TYPE

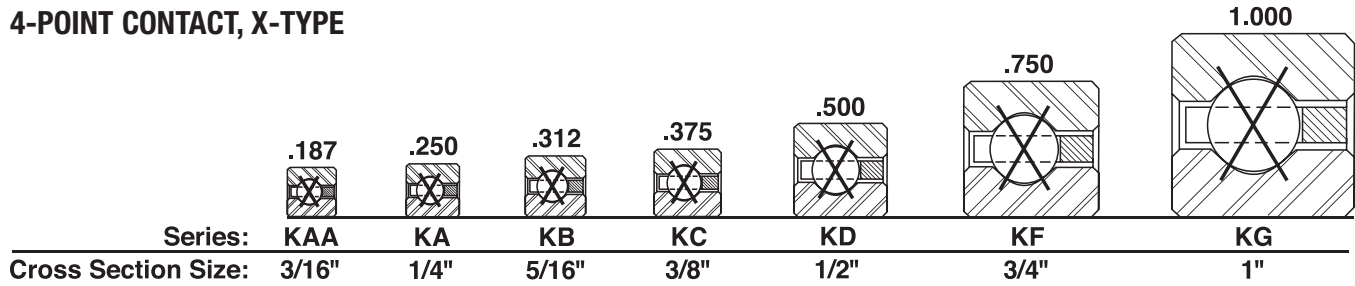

PART NUMBER*	NOMINAL DIMENSIONS												
	B Bore		D Outside Diameter		W Width		Land Diameter				f ₁ Housing Fillet		Ball Diameter
	in.	mm	in.	mm	in.	mm	L _i -Inner Ring		L _o -Outer Ring		in.	mm	in.
KA060XP0*RBC	6.0000	152.400	6.5000	165.100	0.2500	6.350	6.188	157.18	6.313	160.35	0.025	0.64	1/8
KB060XP0*RBC	6.0000	152.400	6.6250	168.275	0.3125	7.938	6.234	158.34	6.391	162.33	0.032	0.81	5/32
KC060XP0*RBC	6.0000	152.400	6.7500	171.450	0.3750	9.525	6.281	159.54	6.469	164.31	0.040	1.02	3/16
KD060XP0*RBC	6.0000	152.400	7.0000	177.800	0.5000	12.700	6.375	161.93	6.625	168.28	0.060	1.52	1/4
KF060XP0*RBC	6.0000	152.400	7.5000	190.500	0.7500	19.050	6.563	166.70	6.938	176.23	0.080	2.03	3/8
KG060XP0*RBC	6.0000	152.400	8.0000	203.200	1.0000	25.400	6.750	171.45	7.250	184.15	0.080	2.03	1/2
KA065XP0*RBC	6.5000	165.100	7.0000	177.800	0.2500	6.350	6.688	169.88	6.813	173.05	0.025	0.64	1/8
KB065XP0*RBC	6.5000	165.100	7.1250	180.975	0.3125	7.938	6.734	171.04	6.891	175.03	0.032	0.81	5/32
KC065XP0*RBC	6.5000	165.100	7.2500	184.150	0.3750	9.525	6.781	172.24	6.969	177.01	0.040	1.02	3/16
KD065XP0*RBC	6.5000	165.100	7.5000	190.500	0.5000	12.700	6.875	174.63	7.125	180.98	0.060	1.52	1/4
KF065XP0*RBC	6.5000	165.100	8.0000	203.200	0.7500	19.050	7.063	179.40	7.438	188.93	0.080	2.03	3/8
KG065XP0*RBC	6.5000	165.100	8.5000	215.900	1.0000	25.400	7.250	184.15	7.750	196.85	0.080	2.03	1/2
KA070XP0*RBC	7.0000	177.800	7.5000	190.500	0.2500	6.350	7.188	182.58	7.313	185.75	0.025	0.64	1/8
KB070XP0*RBC	7.0000	177.800	7.6250	193.675	0.3125	7.938	7.234	183.74	7.391	187.73	0.032	0.81	5/32
KC070XP0*RBC	7.0000	177.800	7.7500	196.850	0.3750	9.525	7.281	184.94	7.469	189.71	0.040	1.02	3/16
KD070XP0*RBC	7.0000	177.800	8.0000	203.200	0.5000	12.700	7.375	187.33	7.625	193.68	0.060	1.52	1/4
KF070XP0*RBC	7.0000	177.800	8.5000	215.900	0.7500	19.050	7.563	192.10	7.938	201.63	0.080	2.03	3/8
KG070XP0*RBC	7.0000	177.800	9.0000	228.600	1.0000	25.400	7.750	196.85	8.250	209.55	0.080	2.03	1/2
KA075XP0*RBC	7.5000	190.500	8.0000	203.200	0.2500	6.350	7.688	195.28	7.813	198.45	0.025	0.64	1/8
KB075XP0*RBC	7.5000	190.500	8.1250	206.375	0.3125	7.938	7.734	196.44	7.891	200.43	0.032	0.81	5/32
KC075XP0*RBC	7.5000	190.500	8.2500	209.550	0.3750	9.525	7.781	197.64	7.969	202.41	0.040	1.02	3/16
KD075XP0*RBC	7.5000	190.500	8.5000	215.900	0.5000	12.700	7.875	200.03	8.125	206.38	0.060	1.52	1/4
KF075XP0*RBC	7.5000	190.500	9.0000	228.600	0.7500	19.050	8.063	204.80	8.438	214.33	0.080	2.03	3/8
KG075XP0*RBC	7.5000	190.500	9.5000	241.300	1.0000	25.400	8.250	209.55	8.750	222.25	0.080	2.03	1/2
KA080XP0*RBC	8.0000	203.200	8.5000	215.900	0.2500	6.350	8.188	207.98	8.313	211.15	0.025	0.64	1/8
KB080XP0*RBC	8.0000	203.200	8.6250	219.075	0.3125	7.938	8.234	209.14	8.391	213.13	0.032	0.81	5/32
KC080XP0*RBC	8.0000	203.200	8.7500	222.250	0.3750	9.525	8.281	210.34	8.469	215.11	0.040	1.02	3/16
KD080XP0*RBC	8.0000	203.200	9.0000	228.600	0.5000	12.700	8.375	212.73	8.625	219.08	0.060	1.52	1/4
KF080XP0*RBC	8.0000	203.200	9.5000	241.300	0.7500	19.050	8.563	217.50	8.938	227.03	0.080	2.03	3/8
KG080XP0*RBC	8.0000	203.200	10.0000	254.000	1.0000	25.400	8.750	222.25	9.250	234.95	0.080	2.03	1/2
KA090XP0*RBC	9.0000	228.600	9.5000	241.300	0.2500	6.350	9.188	233.38	9.313	236.55	0.025	0.64	1/8
KB090XP0*RBC	9.0000	228.600	9.6250	244.475	0.3125	7.938	9.234	234.54	9.391	238.53	0.032	0.81	5/32
KC090XP0*RBC	9.0000	228.600	9.7500	247.650	0.3750	9.525	9.281	235.74	9.469	240.51	0.040	1.02	3/16
KD090XP0*RBC	9.0000	228.600	10.0000	254.000	0.5000	12.700	9.375	238.13	9.625	244.48	0.060	1.52	1/4
KF090XP0*RBC	9.0000	228.600	10.5000	266.700	0.7500	19.050	9.563	242.90	9.938	252.43	0.080	2.03	3/8
KG090XP0*RBC	9.0000	228.600	11.0000	279.400	1.0000	25.400	9.750	247.65	10.250	260.35	0.080	2.03	1/2
KA100XP0*RBC	10.0000	254.000	10.5000	266.700	0.2500	6.350	10.188	258.78	10.313	261.95	0.025	0.64	1/8
KB100XP0*RBC	10.0000	254.000	10.6250	269.875	0.3125	7.938	10.234	259.94	10.391	263.93	0.032	0.81	5/32
KC100XP0*RBC	10.0000	254.000	10.7500	273.050	0.3750	9.525	10.281	261.14	10.469	265.91	0.040	1.02	3/16
KD100XP0*RBC	10.0000	254.000	11.0000	279.400	0.5000	12.700	10.375	263.53	10.625	269.88	0.060	1.52	1/4
KF100XP0*RBC	10.0000	254.000	11.5000	292.100	0.7500	19.050	10.563	268.30	10.938	277.83	0.080	2.03	3/8
KG100XP0*RBC	10.0000	254.000	12.0000	304.800	1.0000	25.400	10.750	273.05	11.250	285.75	0.080	2.03	1/2

*The alphanumeric identification system is used under license.

© 2008, 2011, 2018 RBC Bearings Incorporated. All rights reserved.

THIN SECTION BALL BEARINGS

THIN SECTION BALL BEARINGS — 4-POINT CONTACT, X-TYPE



- 52100 steel
- Large diameter
- Light weight
- Small cross-section
- Snap-over ball separator

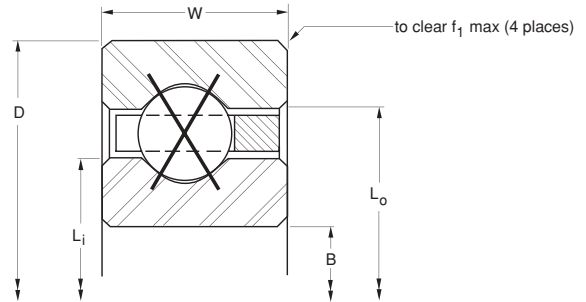

	Ball Quantity	Approx. Weight		LOAD RATINGS												PART NUMBER*
				Radial				Thrust				Moment				
				Static		Dynamic		Static		Dynamic		Static		Dynamic		
lbs.	kg	lbf	N	lbf	N	lbf	N	lbf	N	lbf - in	Nm	lbf - in	Nm			
	75	0.28	0.127	1,900	8,450	955	4,250	4,740	21,080	1,780	7,920	5,930	670	2,240	250	KA060XP0*RBC
	63	0.44	0.200	2,560	11,390	1,371	6,100	6,400	28,470	2,540	11,300	8,080	910	3,247	370	KB060XP0*RBC
	51	0.63	0.286	3,070	13,660	1,770	7,870	7,660	34,070	3,220	14,320	9,770	1,100	4,234	480	KC060XP0*RBC
	39	1.16	0.526	4,450	19,790	2,855	12,700	11,120	49,460	5,610	24,950	14,450	1,630	7,290	820	KD060XP0*RBC
	27	2.70	1.225	7,620	33,900	5,651	25,140	19,050	84,740	10,150	45,150	25,710	2,900	14,311	1,620	KF060XP0*RBC
	21	5.10	2.313	11,490	51,110	9,503	42,270	28,730	127,800	18,290	81,360	40,220	4,540	25,610	2,890	KG060XP0*RBC
	81	0.30	0.136	2,050	9,120	1,001	4,450	5,120	22,770	1,840	8,180	6,910	780	2,535	290	KA065XP0*RBC
	68	0.47	0.213	2,760	12,280	1,435	6,380	6,910	30,740	2,590	11,520	9,410	1,060	3,668	410	KB065XP0*RBC
	55	0.68	0.308	3,310	14,720	1,851	8,230	8,270	36,790	3,300	14,680	11,370	1,280	4,775	540	KC065XP0*RBC
	42	1.22	0.553	4,790	21,310	2,980	13,260	11,970	53,250	5,740	25,530	16,760	1,890	8,040	910	KD065XP0*RBC
	29	2.90	1.315	8,180	36,390	5,880	26,160	20,460	91,010	10,380	46,170	29,660	3,350	15,993	1,810	KF065XP0*RBC
	22	5.40	2.449	12,040	53,560	9,713	43,210	30,100	133,890	18,520	82,380	45,140	5,100	27,770	3,140	KG065XP0*RBC
	87	0.31	0.141	2,200	9,790	1,046	4,650	5,500	24,470	1,850	8,230	7,980	900	2,844	320	KA070XP0*RBC
	73	0.50	0.227	2,970	13,210	1,498	6,660	7,420	33,010	2,660	11,830	10,850	1,230	4,109	460	KB070XP0*RBC
	59	0.73	0.331	3,550	15,790	1,931	8,590	8,870	39,460	3,420	15,210	13,080	1,480	5,341	600	KC070XP0*RBC
	45	1.31	0.594	5,130	22,820	3,103	13,800	12,830	57,070	5,880	26,160	19,240	2,170	8,810	1,000	KD070XP0*RBC
	31	3.20	1.451	8,750	38,920	6,103	27,150	21,870	97,280	10,640	47,330	33,890	3,830	17,744	2,000	KF070XP0*RBC
	24	5.80	2.631	13,130	58,410	10,208	45,410	32,830	146,040	19,330	85,980	52,530	5,940	30,930	3,490	KG070XP0*RBC
	93	0.34	0.154	2,350	10,450	1,089	4,840	5,880	26,160	1,890	8,410	9,120	1,030	3,165	360	KA075XP0*RBC
	78	0.53	0.240	3,170	14,100	1,559	6,930	7,920	35,230	2,730	12,140	12,380	1,400	4,568	520	KB075XP0*RBC
	63	0.78	0.354	3,790	16,860	2,007	8,930	9,470	42,120	3,480	15,480	14,910	1,680	5,930	670	KC075XP0*RBC
	48	1.41	0.640	5,470	24,330	3,222	14,330	13,680	60,850	6,060	26,960	21,890	2,470	9,700	1,100	KD075XP0*RBC
	33	3.40	1.542	9,310	41,410	6,323	28,130	23,280	103,550	10,930	48,620	38,410	4,340	19,568	2,210	KF075XP0*RBC
	25	6.10	2.767	13,680	60,850	10,410	46,310	34,200	152,130	19,460	86,560	58,140	6,570	33,196	3,750	KG075XP0*RBC
	99	0.38	0.172	2,500	11,120	1,131	5,030	6,260	27,850	1,970	8,760	10,330	1,170	3,499	400	KA080XP0*RBC
	83	0.57	0.259	3,370	14,990	1,618	7,200	8,430	37,500	2,790	12,410	14,020	1,580	5,045	570	KB080XP0*RBC
	67	0.84	0.381	4,030	17,930	2,082	9,260	10,070	44,790	3,560	15,840	16,870	1,910	6,542	740	KC080XP0*RBC
	51	1.53	0.694	5,810	25,840	3,338	14,850	14,540	64,680	6,170	27,450	24,710	2,790	10,643	1,200	KD080XP0*RBC
	35	3.50	1.588	9,880	43,950	6,535	29,070	24,690	109,830	11,190	49,780	43,200	4,880	21,453	2,420	KF080XP0*RBC
	27	6.50	2.948	14,770	65,700	10,882	48,410	36,940	164,320	20,230	89,990	66,480	7,510	36,743	4,150	KG080XP0*RBC
	111	0.44	0.200	2,810	12,500	1,212	5,390	7,020	31,230	2,040	9,070	12,990	1,470	4,204	470	KA090XP0*RBC
	93	0.66	0.299	3,780	16,810	1,732	7,700	9,450	42,040	2,890	12,860	17,600	1,990	6,050	680	KB090XP0*RBC
	75	0.94	0.426	4,510	20,060	2,226	9,900	11,270	50,130	3,690	16,410	21,130	2,390	7,830	880	KC090XP0*RBC
	57	1.72	0.780	6,500	28,910	3,561	15,840	16,250	72,280	6,410	28,510	30,870	3,490	12,693	1,430	KD090XP0*RBC
	39	3.90	1.769	11,000	48,930	6,947	30,900	27,510	122,370	11,630	51,730	53,640	6,060	25,410	2,870	KF090XP0*RBC
	30	7.20	3.266	16,420	73,040	11,526	51,270	41,040	182,560	21,020	93,500	82,080	9,270	43,240	4,890	KG090XP0*RBC
	123	0.50	0.227	3,110	13,830	1,289	5,730	7,780	34,610	2,180	9,700	15,940	1,800	4,956	560	KA100XP0*RBC
	103	0.73	0.331	4,190	18,640	1,841	8,190	10,460	46,530	3,080	13,700	21,580	2,440	7,121	800	KB100XP0*RBC
	83	1.06	0.481	4,990	22,200	2,364	10,520	12,470	55,470	3,930	17,480	25,880	2,920	9,201	1,040	KC100XP0*RBC
	63	1.88	0.853	7,180	31,940	3,776	16,800	17,960	79,890	6,680	29,710	37,710	4,260	14,872	1,680	KD100XP0*RBC
	43	4.30	1.950	12,130	53,960	7,342	32,660	30,330	134,910	12,100	53,820	65,210	7,370	29,608	3,350	KF100XP0*RBC
	33	7.90	3.583	18,060	80,330	12,147	54,030	45,140	200,790	21,790	96,930	99,320	11,220	50,124	5,660	KG100XP0*RBC

Refer to the Engineering section for load and speed limitations.

© 2008, 2011, 2018 RBC Bearings Incorporated. All rights reserved.

THIN SECTION BALL BEARINGS

THIN SECTION BALL BEARINGS — 4-POINT CONTACT, X-TYPE



4-POINT CONTACT, X-TYPE

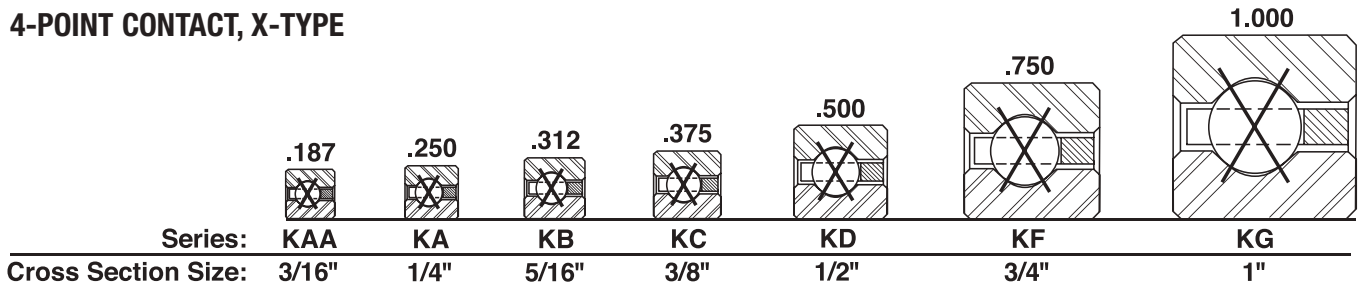

PART NUMBER*	NOMINAL DIMENSIONS												
	B Bore		D Outside Diameter		W Width		Land Diameter				f ₁ Housing Fillet		Ball Diameter
	in.	mm	in.	mm	in.	mm	L _i -Inner Ring		L _o -Outer Ring		in.	mm	in.
KA110XP0*RBC	11.0000	279.400	11.5000	292.100	0.2500	6.350	11.188	284.18	11.313	287.35	0.025	0.64	1/8
KB110XP0*RBC	11.0000	279.400	11.6250	295.275	0.3125	7.938	11.234	285.34	11.391	289.33	0.032	0.81	5/32
KC110XP0*RBC	11.0000	279.400	11.7500	298.450	0.3750	9.525	11.281	286.54	11.469	291.31	0.040	1.02	3/16
KD110XP0*RBC	11.0000	279.400	12.0000	304.800	0.5000	12.700	11.375	288.93	11.625	295.28	0.060	1.52	1/4
KF110XP0*RBC	11.0000	279.400	12.5000	317.500	0.7500	19.050	11.563	293.70	11.938	303.23	0.080	2.03	3/8
KG110XP0*RBC	11.0000	279.400	13.0000	330.200	1.0000	25.400	11.750	298.45	12.250	311.15	0.080	2.03	1/2
KA120XP0*RBC	12.0000	304.800	12.5000	317.500	0.2500	6.350	12.188	309.58	12.313	312.75	0.025	0.64	1/8
KB120XP0*RBC	12.0000	304.800	12.6250	320.675	0.3125	7.938	12.234	310.74	12.391	314.73	0.032	0.81	5/32
KC120XP0*RBC	12.0000	304.800	12.7500	323.850	0.3750	9.525	12.281	311.94	12.469	316.71	0.040	1.02	3/16
KD120XP0*RBC	12.0000	304.800	13.0000	330.200	0.5000	12.700	12.375	314.33	12.625	320.68	0.060	1.52	1/4
KF120XP0*RBC	12.0000	304.800	13.5000	342.900	0.7500	19.050	12.563	319.10	12.938	328.63	0.080	2.03	3/8
KG120XP0*RBC	12.0000	304.800	14.0000	355.600	1.0000	25.400	12.750	323.85	13.250	336.55	0.080	2.03	1/2
KB140XP0*RBC	14.0000	355.600	14.6250	371.475	0.3125	7.938	14.234	361.54	14.391	365.53	0.032	0.81	5/32
KC140XP0*RBC	14.0000	355.600	14.7500	374.650	0.3750	9.525	14.281	362.74	14.469	367.51	0.040	1.02	3/16
KD140XP0*RBC	14.0000	355.600	15.0000	381.000	0.5000	12.700	14.375	365.13	14.625	371.48	0.060	1.52	1/4
KF140XP0*RBC	14.0000	355.600	15.5000	393.700	0.7500	19.050	14.563	369.90	14.938	379.43	0.080	2.03	3/8
KG140XP0*RBC	14.0000	355.600	16.0000	406.400	1.0000	25.400	14.750	374.65	15.250	387.35	0.080	2.03	1/2
KB160XP0*RBC	16.0000	406.400	16.6250	422.275	0.3125	7.938	16.234	412.34	16.391	416.33	0.032	0.81	5/32
KC160XP0*RBC	16.0000	406.400	16.7500	425.450	0.3750	9.525	16.281	413.54	16.469	418.31	0.040	1.02	3/16
KD160XP0*RBC	16.0000	406.400	17.0000	431.800	0.5000	12.700	16.375	415.93	16.625	422.28	0.060	1.52	1/4
KF160XP0*RBC	16.0000	406.400	17.5000	444.500	0.7500	19.050	16.563	420.70	16.938	430.23	0.080	2.03	3/8
KG160XP0*RBC	16.0000	406.400	18.0000	457.200	1.0000	25.400	16.750	425.45	17.250	438.15	0.080	2.03	1/2
KB180XP0*RBC	18.0000	457.200	18.6250	473.075	0.3125	7.938	18.234	463.14	18.391	467.13	0.032	0.81	5/32
KC180XP0*RBC	18.0000	457.200	18.7500	476.250	0.3750	9.525	18.281	464.34	18.469	469.11	0.040	1.02	3/16
KD180XP0*RBC	18.0000	457.200	19.0000	482.600	0.5000	12.700	18.375	466.73	18.625	473.08	0.060	1.52	1/4
KF180XP0*RBC	18.0000	457.200	19.5000	495.300	0.7500	19.050	18.563	471.50	18.938	481.03	0.080	2.03	3/8
KG180XP0*RBC	18.0000	457.200	20.0000	508.000	1.0000	25.400	18.750	476.25	19.250	488.95	0.080	2.03	1/2
KB200XP0*RBC	20.0000	508.000	20.6250	523.875	0.3125	7.938	20.234	513.94	20.391	517.93	0.032	0.81	5/32
KC200XP0*RBC	20.0000	508.000	20.7500	527.050	0.3750	9.525	20.281	515.14	20.469	519.91	0.040	1.02	3/16
KD200XP0*RBC	20.0000	508.000	21.0000	533.400	0.5000	12.700	20.375	517.53	20.625	523.88	0.060	1.52	1/4
KF200XP0*RBC	20.0000	508.000	21.5000	546.100	0.7500	19.050	20.563	522.30	20.938	531.83	0.080	2.03	3/8
KG200XP0*RBC	20.0000	508.000	22.0000	558.800	1.0000	25.400	20.750	527.05	21.250	539.75	0.080	2.03	1/2
KC250XP0*RBC	25.0000	635.000	25.7500	654.050	0.3750	9.525	25.281	642.14	25.469	646.91	0.040	1.02	3/16
KD250XP0*RBC	25.0000	635.000	26.0000	660.400	0.5000	12.700	25.375	644.53	25.625	650.88	0.060	1.52	1/4
KF250XP0*RBC	25.0000	635.000	26.5000	673.100	0.7500	19.050	25.563	649.30	25.938	658.83	0.080	2.03	3/8
KG250XP0*RBC	25.0000	635.000	27.0000	685.800	1.0000	25.400	25.750	654.05	26.250	666.75	0.080	2.03	1/2
KC300XP0*RBC	30.0000	762.000	30.7500	781.050	0.3750	9.525	30.281	769.14	30.469	773.91	0.040	1.02	3/16
KD300XP0*RBC	30.0000	762.000	31.0000	787.400	0.5000	12.700	30.375	771.53	30.625	777.88	0.060	1.52	1/4
KF300XP0*RBC	30.0000	762.000	31.5000	800.100	0.7500	19.050	30.563	776.30	30.938	785.83	0.080	2.03	3/8
KG300XP0*RBC	30.0000	762.000	32.0000	812.800	1.0000	25.400	30.750	781.05	31.250	793.75	0.080	2.03	1/2
KF350XP0*RBC	35.0000	889.000	36.5000	927.100	0.7500	19.050	35.563	903.30	35.938	912.83	0.080	2.03	3/8
KG350XP0*RBC	35.0000	889.000	37.0000	939.800	1.0000	25.400	35.750	908.05	36.250	920.75	0.080	2.03	1/2
KF400XP0*RBC	40.0000	1016.000	41.5000	1054.100	0.7500	19.050	40.563	1030.30	40.938	1039.83	0.080	2.03	3/8
KG400XP0*RBC	40.0000	1016.000	42.0000	1066.800	1.0000	25.400	40.750	1035.05	41.250	1047.75	0.080	2.03	1/2

*The alphanumeric identification system is used under license.

© 2008, 2011, 2018 RBC Bearings Incorporated. All rights reserved.

THIN SECTION BALL BEARINGS

THIN SECTION BALL BEARINGS — 4-POINT CONTACT, X-TYPE



- 52100 steel
- Large diameter
- Light weight
- Small cross-section
- Snap-over ball separator

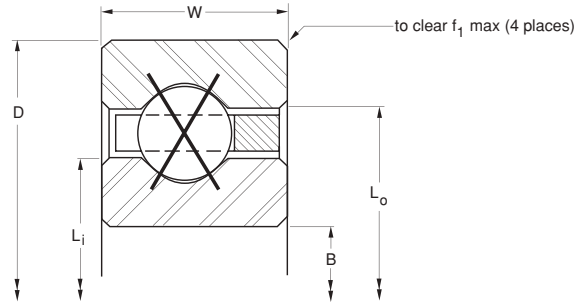

	Ball Quantity	Approx. Weight		LOAD RATINGS												PART NUMBER*
				Radial				Thrust				Moment				
				Static		Dynamic		Static		Dynamic		Static		Dynamic		
lbs.	kg	lbf	N	lbf	N	lbf	N	lbf	N	lbf - in	Nm	lbf - in	Nm			
	135	0.52	0.236	3,410	15,170	1,362	6,060	8,540	37,990	2,320	10,320	19,210	2,170	5,750	650	KA110XP0*RBC
	113	0.75	0.340	4,590	20,420	1,945	8,650	11,480	51,070	3,280	14,590	25,970	2,930	8,254	930	KB110XP0*RBC
	91	1.16	0.526	5,470	24,330	2,496	11,100	13,680	60,850	4,180	18,590	31,110	3,510	10,651	1,200	KC110XP0*RBC
	69	2.06	0.934	7,870	35,010	3,981	17,710	19,670	87,500	6,830	30,380	45,230	5,110	17,173	1,940	KD110XP0*RBC
	47	4.80	2.177	13,260	58,980	7,721	34,340	33,150	147,460	12,490	55,560	77,910	8,800	34,032	3,850	KF110XP0*RBC
	36	8.60	3.901	19,700	87,630	12,739	56,670	49,250	219,070	22,530	100,220	118,200	13,350	57,347	6,480	KG110XP0*RBC
	147	0.56	0.254	3,720	16,550	1,433	6,370	9,300	41,370	2,450	10,900	22,770	2,570	6,587	740	KA120XP0*RBC
	123	0.83	0.376	5,000	22,240	2,045	9,100	12,500	55,600	3,470	15,440	30,770	3,480	9,446	1,070	KB120XP0*RBC
	99	1.25	0.567	5,950	26,470	2,622	11,660	14,880	66,190	4,420	19,660	36,830	4,160	12,174	1,380	KC120XP0*RBC
	75	2.25	1.021	8,550	38,030	4,178	18,580	21,380	95,100	7,080	31,490	53,440	6,040	19,590	2,210	KD120XP0*RBC
	51	5.20	2.359	14,390	64,010	8,084	35,960	35,970	160,000	13,190	58,670	91,730	10,360	38,666	4,370	KF120XP0*RBC
	39	9.30	4.218	21,340	94,930	13,315	59,230	53,350	237,310	23,180	103,110	138,700	15,670	64,935	7,340	KG120XP0*RBC
	143	1.05	0.476	5,810	25,840	2,234	9,940	14,530	64,630	3,840	17,080	41,580	4,700	11,994	1,360	KB140XP0*RBC
	115	1.52	0.689	6,910	30,740	2,862	12,730	17,280	76,870	4,890	21,750	49,690	5,610	15,434	1,740	KC140XP0*RBC
	87	2.73	1.238	9,920	44,130	4,551	20,240	24,800	110,320	7,670	34,120	71,910	8,120	24,755	2,800	KD140XP0*RBC
	59	6.00	2.722	16,650	74,060	8,775	39,030	41,620	185,130	14,530	64,630	122,800	13,870	48,556	5,490	KF140XP0*RBC
	45	10.80	4.899	24,620	109,520	14,404	64,070	61,560	273,830	24,300	108,090	184,700	20,870	81,056	9,160	KG140XP0*RBC
	163	1.20	0.544	6,620	29,450	2,410	10,720	16,560	73,660	4,190	18,640	54,020	6,100	14,750	1,670	KB160XP0*RBC
	131	1.73	0.785	7,880	35,050	3,086	13,730	19,690	87,590	5,330	23,710	64,480	7,290	18,955	2,140	KC160XP0*RBC
	99	3.10	1.406	11,290	50,220	4,899	21,790	28,220	125,530	8,360	37,190	93,110	10,520	30,325	3,430	KD160XP0*RBC
	67	7.10	3.221	18,900	84,070	9,421	41,910	47,260	210,220	15,820	70,370	158,300	17,890	59,200	6,690	KF160XP0*RBC
	51	12.30	5.579	27,910	124,150	15,425	68,610	69,770	310,350	25,510	113,470	237,200	26,800	98,373	11,110	KG160XP0*RBC
	183	1.35	0.612	7,440	33,090	2,576	11,460	18,590	82,690	4,520	20,110	68,090	7,690	17,694	2,000	KB180XP0*RBC
	147	1.94	0.880	8,840	39,320	3,295	14,660	22,090	98,260	5,760	25,620	81,190	9,170	22,712	2,570	KC180XP0*RBC
	111	3.48	1.579	12,650	56,270	5,226	23,250	31,640	140,740	9,030	40,170	117,000	13,220	36,268	4,100	KD180XP0*RBC
	75	7.90	3.583	21,160	94,120	10,028	44,610	52,900	235,310	17,060	75,890	198,400	22,420	70,537	7,970	KF180XP0*RBC
	57	13.70	6.214	31,190	138,740	16,386	72,890	77,980	346,870	27,410	121,930	296,300	33,480	116,793	13,200	KG180XP0*RBC
	203	1.50	0.680	8,250	36,700	2,731	12,150	20,620	91,720	4,850	21,570	83,780	9,470	20,813	2,350	KB200XP0*RBC
	163	2.16	0.980	9,800	43,590	3,492	15,530	24,500	108,980	6,170	27,450	99,830	11,280	26,695	3,020	KC200XP0*RBC
	123	3.85	1.746	14,020	62,360	5,534	24,620	35,060	155,950	9,670	43,010	143,700	16,240	42,561	4,810	KD200XP0*RBC
	83	8.90	4.037	23,420	104,180	10,602	47,160	58,550	260,440	18,250	81,180	243,000	27,460	82,528	9,320	KF200XP0*RBC
	63	15.80	7.167	34,470	153,330	17,293	76,920	86,180	383,350	29,300	130,330	362,000	40,900	136,238	15,390	KG200XP0*RBC
	203	2.69	1.220	12,200	54,270	3,941	17,530	30,510	135,720	7,140	31,760	154,800	17,490	37,518	4,240	KC250XP0*RBC
	153	4.79	2.173	17,440	77,580	6,235	27,730	43,610	193,990	11,180	49,730	222,400	25,130	59,649	6,740	KD250XP0*RBC
	103	10.90	4.944	29,060	129,270	11,909	52,970	72,650	323,160	21,070	93,720	374,200	42,280	115,037	13,000	KF250XP0*RBC
	78	19.50	8.845	42,680	189,850	19,360	86,120	106,700	474,630	33,780	150,260	554,900	62,700	188,838	21,340	KG250XP0*RBC
	243	3.21	1.456	14,610	64,990	4,338	19,300	36,520	162,450	8,050	35,810	221,900	25,070	49,436	5,590	KC300XP0*RBC
	183	5.73	2.599	20,860	92,790	6,856	30,500	52,160	232,020	12,600	56,050	318,100	35,940	78,447	8,860	KD300XP0*RBC
	123	13.00	5.897	34,700	154,350	13,065	58,120	86,760	385,930	23,720	105,510	533,600	60,290	150,708	17,030	KF300XP0*RBC
	93	23.30	10.569	50,890	226,370	21,200	94,300	127,200	565,810	37,980	168,940	788,800	89,120	246,541	27,860	KG300XP0*RBC
	143	15.10	6.849	40,350	179,490	14,100	62,720	100,900	448,830	26,220	116,630	721,200	81,480	189,106	21,370	KF350XP0*RBC
	108	27.10	12.292	59,100	262,890	22,845	101,620	147,700	657,000	41,970	186,690	1,064,000	120,220	308,527	34,860	KG350XP0*RBC
	163	17.20	7.802	45,990	204,570	15,034	66,870	115,000	511,550	28,620	127,310	937,100	105,880	229,832	25,970	KF400XP0*RBC
	123	30.80	13.971	67,310	299,410	24,332	108,230	168,300	748,640	45,770	203,600	1,380,000	155,920	374,256	42,290	KG400XP0*RBC

Refer to the Engineering section for load and speed limitations.

© 2008, 2011, 2018 RBC Bearings Incorporated. All rights reserved.

SEALED (MOLDED) RADIAL CONTACT, C-TYPE

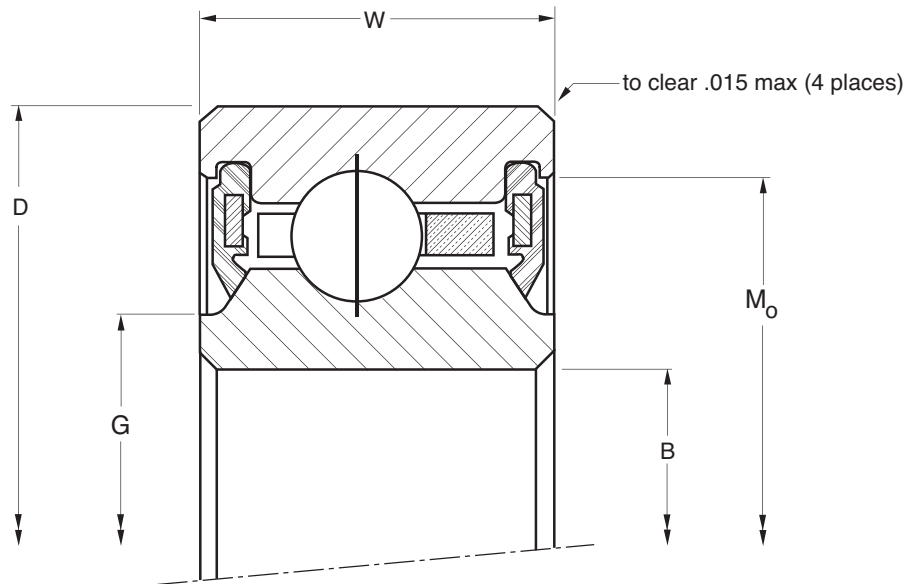

PART NUMBER*	NOMINAL DIMENSIONS										Ball Diameter	Ball Quantity
	B Bore		D Outside Diameter		W Width		G Recess Diameter		Mo Groove Diameter			
	in.	mm	in.	mm	in.	mm	in.	mm	in.	mm		
JU040CP0*RBC	4.0000	101.600	4.7500	120.650	0.5000	12.700	4.155	105.54	4.550	115.57	3/16	35
JU042CP0*RBC	4.2500	107.950	5.0000	127.000	0.5000	12.700	4.405	111.89	4.800	121.92	3/16	37
JU045CP0*RBC	4.5000	114.300	5.2500	133.350	0.5000	12.700	4.655	118.24	5.050	128.27	3/16	39
JU047CP0*RBC	4.7500	120.650	5.5000	139.700	0.5000	12.700	4.905	124.59	5.300	134.62	3/16	41
JU050CP0*RBC	5.0000	127.000	5.7500	146.050	0.5000	12.700	5.155	130.94	5.550	140.97	3/16	43
JU055CP0*RBC	5.5000	139.700	6.2500	158.750	0.5000	12.700	5.655	143.64	6.050	153.67	3/16	47
JU060CP0*RBC	6.0000	152.400	6.7500	171.450	0.5000	12.700	6.155	156.34	6.550	166.37	3/16	51
JU065CP0*RBC	6.5000	165.100	7.2500	184.150	0.5000	12.700	6.655	169.04	7.050	179.07	3/16	55
JU070CP0*RBC	7.0000	177.800	7.7500	196.850	0.5000	12.700	7.155	181.74	7.550	191.77	3/16	59
JU075CP0*RBC	7.5000	190.500	8.2500	209.550	0.5000	12.700	7.655	194.44	8.050	204.47	3/16	63
JU080CP0*RBC	8.0000	203.200	8.7500	222.250	0.5000	12.700	8.155	207.14	8.550	217.17	3/16	67
JU090CP0*RBC	9.0000	228.600	9.7500	247.650	0.5000	12.700	9.155	232.54	9.550	242.57	3/16	75
JU100CP0*RBC	10.0000	254.000	10.7500	273.050	0.5000	12.700	10.155	257.94	10.550	267.97	3/16	83
JU110CP0*RBC	11.0000	279.400	11.7500	298.450	0.5000	12.700	11.155	283.34	11.550	293.37	3/16	91
JU120CP0*RBC	12.0000	304.800	12.7500	323.850	0.5000	12.700	12.155	308.74	12.550	318.77	3/16	99

*The alphanumeric identification system is used under license.
JU Series are also available in low-torque design using PTFE seals.

THIN SECTION BALL BEARINGS



- 52100 steel
- Large diameter
- Light weight
- Small cross-section
- Snap-over ball separator
- Sealed

	Approx. Weight		LOAD RATINGS										PART NUMBER*		
			Radial				Thrust				Moment				
			Static		Dynamic		Static		Dynamic		Static			Dynamic	
lbs.	kg	lbf	N	lbf	N	lbf	N	lbf	N	lbf - in	Nm	lbf - in	Nm		
	0.55	0.249	2,100	9,340	1,290	5,740	N/A	N/A	N/A	N/A	N/A	N/A	N/A	N/A	JU040CP0*RBC
	0.58	0.263	2,220	9,880	1,320	5,870	N/A	N/A	N/A	N/A	N/A	N/A	N/A	N/A	JU042CP0*RBC
	0.61	0.277	2,340	10,410	1,350	6,010	N/A	N/A	N/A	N/A	N/A	N/A	N/A	N/A	JU045CP0*RBC
	0.65	0.295	2,460	10,940	1,370	6,090	N/A	N/A	N/A	N/A	N/A	N/A	N/A	N/A	JU047CP0*RBC
	0.68	0.308	2,590	11,520	1,390	6,180	N/A	N/A	N/A	N/A	N/A	N/A	N/A	N/A	JU050CP0*RBC
	0.74	0.336	2,830	12,590	1,440	6,410	N/A	N/A	N/A	N/A	N/A	N/A	N/A	N/A	JU055CP0*RBC
	0.81	0.367	3,070	13,660	1,490	6,630	N/A	N/A	N/A	N/A	N/A	N/A	N/A	N/A	JU060CP0*RBC
	0.87	0.395	3,315	14,750	1,530	6,810	N/A	N/A	N/A	N/A	N/A	N/A	N/A	N/A	JU065CP0*RBC
	0.93	0.422	3,550	15,790	1,570	6,980	N/A	N/A	N/A	N/A	N/A	N/A	N/A	N/A	JU070CP0*RBC
	0.99	0.449	3,790	16,860	1,600	7,120	N/A	N/A	N/A	N/A	N/A	N/A	N/A	N/A	JU075CP0*RBC
	1.06	0.481	4,030	17,930	1,650	7,340	N/A	N/A	N/A	N/A	N/A	N/A	N/A	N/A	JU080CP0*RBC
	1.18	0.535	4,510	20,060	1,730	7,700	N/A	N/A	N/A	N/A	N/A	N/A	N/A	N/A	JU090CP0*RBC
	1.31	0.594	4,990	22,200	1,781	7,920	N/A	N/A	N/A	N/A	N/A	N/A	N/A	N/A	JU100CP0*RBC
	1.43	0.649	5,470	24,330	1,879	8,360	N/A	N/A	N/A	N/A	N/A	N/A	N/A	N/A	JU110CP0*RBC
	1.56	0.708	5,950	26,470	1,974	8,780	N/A	N/A	N/A	N/A	N/A	N/A	N/A	N/A	JU120CP0*RBC

Refer to the Engineering section for load and speed limitations.

THIN SECTION BALL BEARINGS

SEALED (MOLDED) 4-POINT CONTACT, X-TYPE

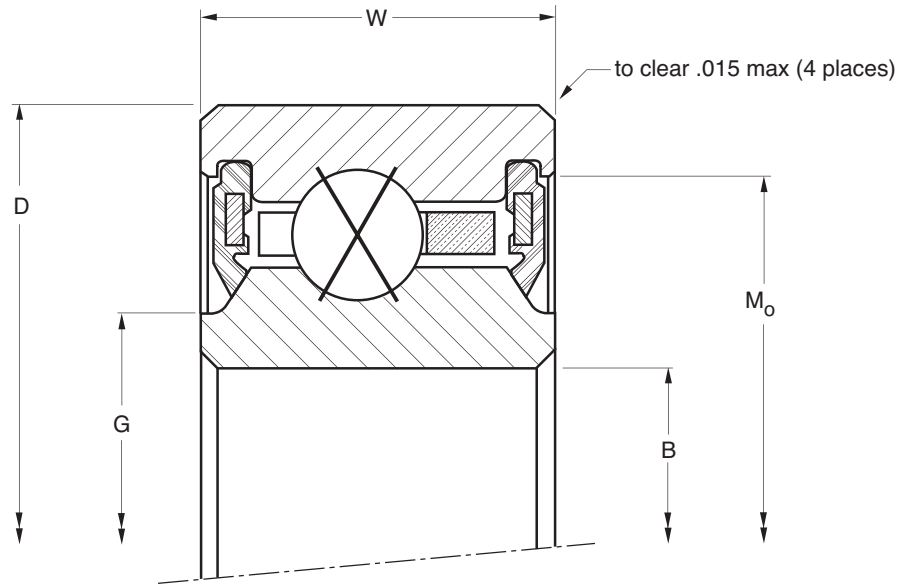

PART NUMBER*	NOMINAL DIMENSIONS										Ball Diameter	Ball Quantity
	B Bore		D Outside Diameter		W Width		G Recess Diameter		Mo Groove Diameter			
	in.	mm	in.	mm	in.	mm	in.	mm	in.	mm		
JU040XP0*RBC	4.0000	101.600	4.7500	120.650	0.5000	12.700	4.155	105.54	4.550	115.57	3/16	35
JU042XP0*RBC	4.2500	107.950	5.0000	127.000	0.5000	12.700	4.405	111.89	4.800	121.92	3/16	37
JU045XP0*RBC	4.5000	114.300	5.2500	133.350	0.5000	12.700	4.655	118.24	5.050	128.27	3/16	39
JU047XP0*RBC	4.7500	120.650	5.5000	139.700	0.5000	12.700	4.905	124.59	5.300	134.62	3/16	41
JU050XP0*RBC	5.0000	127.000	5.7500	146.050	0.5000	12.700	5.155	130.94	5.550	140.97	3/16	43
JU055XP0*RBC	5.5000	139.700	6.2500	158.750	0.5000	12.700	5.655	143.64	6.050	153.67	3/16	47
JU060XP0*RBC	6.0000	152.400	6.7500	171.450	0.5000	12.700	6.155	156.34	6.550	166.37	3/16	51
JU065XP0*RBC	6.5000	165.100	7.2500	184.150	0.5000	12.700	6.655	169.04	7.050	179.07	3/16	55
JU070XP0*RBC	7.0000	177.800	7.7500	196.850	0.5000	12.700	7.155	181.74	7.550	191.77	3/16	59
JU075XP0*RBC	7.5000	190.500	8.2500	209.550	0.5000	12.700	7.655	194.44	8.050	204.47	3/16	63
JU080XP0*RBC	8.0000	203.200	8.7500	222.250	0.5000	12.700	8.155	207.14	8.550	217.17	3/16	67
JU090XP0*RBC	9.0000	228.600	9.7500	247.650	0.5000	12.700	9.155	232.54	9.550	242.57	3/16	75
JU100XP0*RBC	10.0000	254.000	10.7500	273.050	0.5000	12.700	10.155	257.94	10.550	267.97	3/16	83
JU110XP0*RBC	11.0000	279.400	11.7500	298.450	0.5000	12.700	11.155	283.34	11.550	293.37	3/16	91
JU120XP0*RBC	12.0000	304.800	12.7500	323.850	0.5000	12.700	12.155	308.74	12.550	318.77	3/16	99

*The alphanumeric identification system is used under license.
JU Series are also available in low-torque design using PTFE seals.

THIN SECTION BALL BEARINGS



- 52100 steel
- Large diameter
- Light weight
- Small cross-section
- Snap-over ball separator
- Sealed

	Approx. Weight		LOAD RATINGS										PART NUMBER*	
			Radial				Thrust				Moment			
			Static		Dynamic		Static		Dynamic		Static			Dynamic
lbs.	kg	lbf	N	lbf	N	lbf	N	lbf	N	lbf - in	Nm	lbf - in	Nm	
0.55	0.249	2,100	9,340	1,417	6,300	5,260	23,400	2,810	12,500	4,600	520	2,460	280	JU040XP0*RBC
0.58	0.263	2,220	9,880	1,464	6,510	5,560	24,730	2,870	12,770	5,140	580	2,650	300	JU042XP0*RBC
0.61	0.277	2,340	10,410	1,510	6,720	5,860	26,070	2,920	12,990	5,710	650	2,850	320	JU045XP0*RBC
0.65	0.295	2,460	10,940	1,556	6,920	6,160	27,400	2,970	13,210	6,320	710	3,040	340	JU047XP0*RBC
0.68	0.308	2,590	11,520	1,600	7,120	6,460	28,740	3,040	13,520	6,950	790	3,270	370	JU050XP0*RBC
0.74	0.336	2,830	12,590	1,687	7,500	7,060	31,400	3,120	13,880	8,300	940	3,717	420	JU055XP0*RBC
0.81	0.367	3,070	13,660	1,770	7,870	7,660	34,070	3,220	14,320	9,770	1,100	4,234	480	JU060XP0*RBC
0.87	0.395	3,310	14,720	1,851	8,230	8,270	36,790	3,300	14,680	11,370	1,280	4,775	540	JU065XP0*RBC
0.93	0.422	3,550	15,790	1,931	8,590	8,870	39,460	3,420	15,210	13,080	1,480	5,341	600	JU070XP0*RBC
0.99	0.449	3,790	16,860	2,007	8,930	9,470	42,120	3,480	15,480	14,910	1,680	5,930	670	JU075XP0*RBC
1.06	0.481	4,030	17,930	2,082	9,260	10,070	44,790	3,560	15,840	16,870	1,910	6,542	740	JU080XP0*RBC
1.18	0.535	4,510	20,060	2,226	9,900	11,270	50,130	3,690	16,410	21,130	2,390	7,830	880	JU090XP0*RBC
1.31	0.594	4,990	22,200	2,364	10,520	12,470	55,470	3,930	17,480	25,880	2,920	9,201	1,040	JU100XP0*RBC
1.43	0.649	5,470	24,330	2,496	11,100	13,680	60,850	4,180	18,590	31,110	3,510	10,651	1,200	JU110XP0*RBC
1.56	0.708	5,950	26,470	2,622	11,660	14,880	66,190	4,420	19,660	36,830	4,160	12,174	1,380	JU120XP0*RBC

Refer to the Engineering section for load and speed limitations.

THIN SECTION BALL BEARINGS

SUPERDUPLEX™ SEALED BEARINGS, NARROW WIDTH SERIES

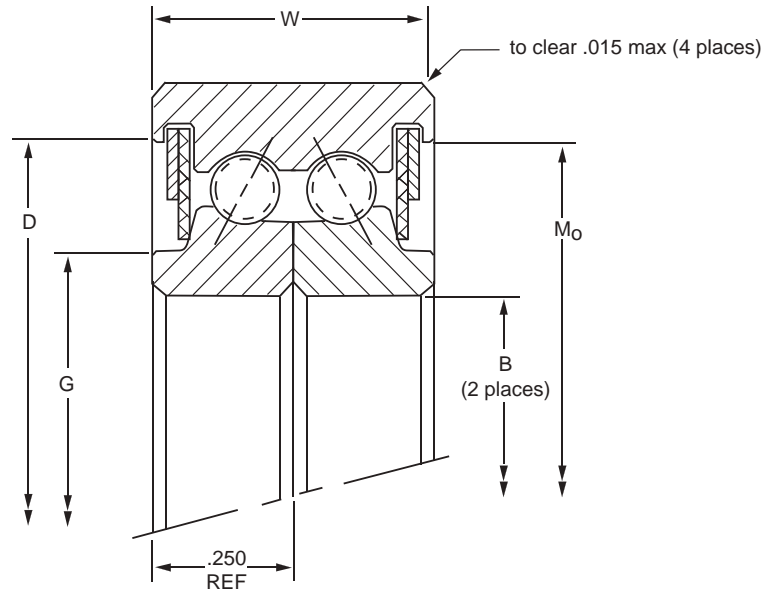

PART NUMBER*	NOMINAL DIMENSIONS											
	B Bore		D Outside Diameter		W Width		G Recess Diameter		Mo Groove Diameter		Ball Diameter	Ball Quantity
	in.	mm	in.	mm	in.	mm	in.	mm	in.	mm	in.	in.
ZU040MZ3*RBC	4.0000	101.600	4.7500	120.650	0.5000	12.700	4.155	105.54	4.550	115.57	1/8	54
ZU042MZ3*RBC	4.2500	107.950	5.0000	127.000	0.5000	12.700	4.405	111.89	4.800	121.92	1/8	57
ZU045MZ3*RBC	4.5000	114.300	5.2500	133.350	0.5000	12.700	4.655	118.24	5.050	128.27	1/8	60
ZU047MZ3*RBC	4.7500	120.650	5.5000	139.700	0.5000	12.700	4.905	124.59	5.300	134.62	1/8	63
ZU050MZ3*RBC	5.0000	127.000	5.7500	146.050	0.5000	12.700	5.155	130.94	5.550	140.97	1/8	66
ZU055MZ3*RBC	5.5000	139.700	6.2500	158.750	0.5000	12.700	5.655	143.64	6.050	153.67	1/8	72
ZU060MZ3*RBC	6.0000	152.400	6.7500	171.450	0.5000	12.700	6.155	156.34	6.550	166.37	1/8	79
ZU065MZ3*RBC	6.5000	165.100	7.2500	184.150	0.5000	12.700	6.655	169.04	7.050	179.07	1/8	85
ZU070MZ3*RBC	7.0000	177.800	7.7500	196.850	0.5000	12.700	7.155	181.74	7.550	191.77	1/8	91
ZU075MZ3*RBC	7.5000	190.500	8.2500	209.550	0.5000	12.700	7.655	194.44	8.050	204.47	1/8	97
ZU080MZ3*RBC	8.0000	203.200	8.7500	222.250	0.5000	12.700	8.155	207.14	8.550	217.17	1/8	104
ZU090MZ3*RBC	9.0000	228.600	9.7500	247.650	0.5000	12.700	9.155	232.54	9.550	242.57	1/8	116
ZU100MZ3*RBC	10.0000	254.000	10.7500	273.050	0.5000	12.700	10.155	257.94	10.550	267.97	1/8	129
ZU110MZ3*RBC	11.0000	279.400	11.7500	298.450	0.5000	12.700	11.155	283.34	11.550	293.37	1/8	141
ZU120MZ3*RBC	12.0000	304.800	12.7500	323.850	0.5000	12.700	12.155	308.74	12.550	318.77	1/8	154

*The alphanumeric identification system is used under license.
JU Series are also available in low-torque design using PTFE seals.

THIN SECTION BALL BEARINGS

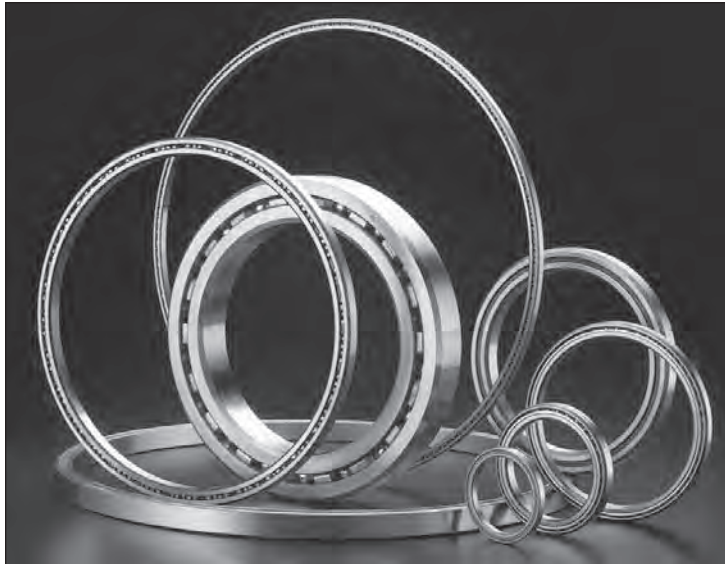

- 440C steel
- ABEC - 3F
- High stiffness
- Low Torque
- Spacer ball separator
- Shielded seals

	Approx. Weight		LOAD RATINGS										PART NUMBER*	
			Radial [†]				Thrust				Moment			
			Static		Dynamic		Static		Dynamic		Static	Dynamic		
lbs.	kg	lbf	N	lbf	N	lbf	N	lbf	N	lbf - in	Nm	lbf - in	Nm	
0.55	0.249	(2x) 905	(2x) 4,030	(2x) 640	(2x) 2,850	2,710	12,050	1,850	8,230	4,130	470	1,555	180	ZU040MZ3*RBC
0.58	0.263	(2x) 950	(2x) 4,230	(2x) 655	(2x) 2,910	2,850	12,680	1,900	8,450	4,540	510	1,670	190	ZU042MZ3*RBC
0.61	0.277	(2x) 995	(2x) 4,430	(2x) 660	(2x) 2,940	2,990	13,300	1,915	8,520	5,070	570	1,840	210	ZU045MZ3*RBC
0.65	0.295	(2x) 1,050	(2x) 4,670	(2x) 675	(2x) 3,000	3,140	13,970	1,955	8,700	5,575	630	1,990	220	ZU047MZ3*RBC
0.68	0.308	(2x) 1,090	(2x) 4,850	(2x) 685	(2x) 3,050	3,285	14,610	1,995	8,870	6,105	690	2,130	240	ZU050MZ3*RBC
0.74	0.336	(2x) 1,190	(2x) 5,290	(2x) 700	(2x) 3,110	3,580	15,920	2,035	9,050	7,235	820	2,450	280	ZU055MZ3*RBC
0.81	0.367	(2x) 1,305	(2x) 5,800	(2x) 730	(2x) 3,250	3,925	17,460	2,125	9,450	8,575	970	2,835	320	ZU060MZ3*RBC
0.87	0.395	(2x) 1,400	(2x) 6,230	(2x) 755	(2x) 3,360	4,210	18,730	2,185	9,720	9,910	1,120	3,200	360	ZU065MZ3*RBC
0.93	0.422	(2x) 1,500	(2x) 6,670	(2x) 760	(2x) 3,380	4,495	19,990	2,200	9,790	11,340	1,280	3,565	400	ZU070MZ3*RBC
0.99	0.449	(2x) 1,600	(2x) 7,120	(2x) 775	(2x) 3,450	4,780	21,260	2,250	10,010	12,870	1,450	3,950	450	ZU075MZ3*RBC
1.06	0.481	(2x) 1,710	(2x) 7,610	(2x) 815	(2x) 3,630	5,130	22,820	2,350	10,450	14,630	1,650	4,405	500	ZU080MZ3*RBC
1.18	0.535	(2x) 1,905	(2x) 8,470	(2x) 840	(2x) 3,740	5,705	25,380	2,420	10,760	18,180	2,050	5,275	600	ZU090MZ3*RBC
1.31	0.594	(2x) 2,110	(2x) 9,390	(2x) 875	(2x) 3,890	6,330	28,160	2,550	11,340	22,290	2,520	6,250	710	ZU100MZ3*RBC
1.43	0.649	(2x) 2,300	(2x) 10,230	(2x) 905	(2x) 4,030	6,915	30,760	2,625	11,680	26,620	3,010	7,235	820	ZU110MZ3*RBC
1.56	0.708	(2x) 2,515	(2x) 11,190	(2x) 935	(2x) 4,160	7,545	33,560	2,720	12,100	31,560	3,570	8,330	940	ZU120MZ3*RBC

[†]Radial load rating is two times the value per row ideally if both rows share load equally.
Refer to the Engineering section for load and speed limitations.

THIN SECTION BALL BEARINGS

THIN SECTION BALL BEARINGS — Y-PWI (DUPLEX)



Y-PWI SERIES

- Mounted in duplex pairs
- Combination PTFE seals with stainless steel caps
- Exposed surfaces (except bore) are cadmium plated
- Prepacked with lubricant conforming to military specifications

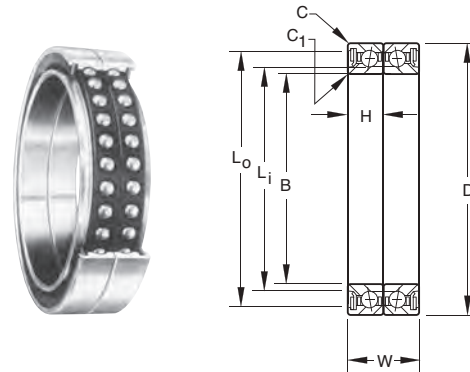

SPECIFICATIONS AND ORDERING INFORMATION

DIMENSIONS — TOLERANCES

Bearing Number	B Bore		D Outside Diameter		W Widths		H		L _i		L _o		C ₁ (1) Inner Ring Radius		c(1) Outer Ring Radius		Balls No.	Size	Weight (Ea. Bearing)	
	in.	mm	in.	mm	in.	mm	in.	mm	in.	mm	in.	mm	in.	mm	in.	mm			lbs.	kg
Y64PWI-CR DB	4.0000	101.600	5.1250	130.175	1.250	31.75	.625	15.88	4.250	108.00	4.815	122.30	.031	0.79	.031	0.79	36	5/16	.97	.440
	3.9992	101.580	5.1242	130.155																
Y80PWI-CR DB	5.0000	127.000	6.1250	155.575	1.250	31.75	.625	15.88	5.250	133.40	5.801	147.35	.031	0.79	.031	0.79	44	5/16	1.18	.535
	4.9990	126.975	6.1240	155.550																
Y96PWI-CR DB	6.0000	152.400	7.1250	180.975	1.250	31.75	.625	15.88	6.250	158.80	6.801	172.75	.031	0.79	.031	0.79	52	5/16	1.39	.630
	5.9990	152.375	7.1240	180.950																
Y128PWI-CR DB	8.0000	203.200	9.1250	231.775	1.250	31.75	.625	15.88	8.252	209.60	8.801	232.55	.031	0.79	.031	0.79	66	5/16	1.82	.826
	7.9988	203.170	9.1238	231.745																
Y176PWI-CR DB	11.0000	279.400	12.500	317.500	1.500	38.10	.750	19.05	11.375	288.90	12.036	305.70	.031	0.79	.031	0.79	76	3/8	4.37	1.98
	10.9986	279.364	12.4984	317.460																
Y224PWI-CR DB	14.0000	355.600	15.500	393.700	1.500	38.10	.750	19.05	14.375	365.10	15.036	381.90	.031	0.79	.031	0.79	95	3/8	5.81	2.64
	13.9984	355.560	15.4984	393.660																
Y288PWI-2-MBR DB	18.0000	457.200	20.0000	508.000	2.000	50.80	1.000	25.40	18.500	469.90	19.500	495.30	.031	0.79	.031	0.79	92	1/2	13.20	5.99
	17.9983	457.157	19.9981	507.952																

(1) Maximum shaft or housing fillet radius which bearing corners will clear.

LOAD RATINGS

Bearing Number	Radial Limit Load Rating		Thrust Limit Load Rating		Limit Moment Rating		Moment Constant		Rated Radial Capacity at Various RPM Based on 7500 Hours Average Life ⁽¹⁾						Nominal Preload	
	lbs.	N	lbs.	N	lb.-in.	N-cm	1/in.	1/cm	100rpm ⁽²⁾		300rpm ⁽²⁾		500rpm ⁽²⁾			
Y64PWI-CR DB	38500	170000	17500	78000	29700	335550	.589	.232	3480	15500	2410	10700	2030	9000	90	400
Y80PWI-CR DB	47300	210000	21500	95000	42100	475650	.511	.200	3770	16700	2610	11600	2200	9800	100	440
Y96PWI-CR DB	55800	248000	25400	112000	56800	641730	.447	.175	4030	17900	2800	12500	2360	10400	130	580
Y128PWI-CR DB	70900	315000	32200	143000	89100	1006700	.361	.142	4280	19000	2960	13200	2500	11200	160	710
Y176PWI-CR DB	117500	522000	53400	237000	199000	2248300	.268	.105	6180	27500	4280	19000	3610	16000	270	1200
Y224PWI-CR DB	147000	654000	66800	297000	302600	3418900	.221	.088	7090	31500	4920	21900	4140	18400	330	1470
Y288PWI-2-MBR DB	253000	1120000	115000	510000	1357500	15337000	.085	.033	10090	44900	7000	31000	5900	26200	575	2560

The limit load ratings shown apply only to airframe control position where bearings are used for oscillatory service.

Equivalent Radial Load = .52 x Radial Load + 1.91 x Thrust Load or = Radial Load, whichever is greater.

Pure Thrust Rating = .84 Radial Rating at operating speed.

(1) These ratings are for single bearings.

(2) Heavy line indicates limiting speeds recommended for sealed bearings; for higher speeds, seals should be removed.

THERMAL-COMP[®] Bearings are custom designed to compensate for adverse effects of temperature extremes on bearing performance in airborne applications.

THERMAL-COMP[®] Bearings have a double-split rings design and once properly installed in bearing support structure at ambient temperature, they will maintain steady and predictable stiffness and torque characteristics throughout a temperature range, regardless of differences in coefficient of thermal expansion (CTE) of the bearing and the support structure materials.

In most airborne systems, large azimuth bearings are installed in support structures (shaft and housing), which have to be made from light aluminum alloys in order to control weight. While conventional bearings may be installed and fitted for optimum stiffness and rotational torque at ambient temperature, significant variations in bearing performance will be experienced at extremes of temperature in actual application. Such variations are caused by differences in CTE of bearing materials (hardened steels) and the aluminum alloys used for the support structure. At one temperature extreme, the bearing will be internally over-loaded to a much higher stiffness and rolling friction torque; yet at another extreme, the bearing internal preload may be compromised resulting in loss of stiffness or excessive deflection. Such undesirable variations in conventional bearing performance at extremes of temperature will have to be carefully analyzed and consequences mitigated, often necessitating utilization of larger drive motors and/or using more expensive support structure alloys with CTE properties as close to bearing steel as possible. With **THERMAL-COMP[®] Bearings** such uncertainties in performance are greatly reduced.

The following is a typical illustration of **THERMAL-COMP[®] Bearings** manufactured at RBC-Industrial Tectonics Bearings. Note that the free-state gap in ring split is determined based on bearing size and application temperatures involved. The gap will be closed to near zero when the bearing is operating at the coldest temperature in the application. The gap will be slightly wider when bearing is operating at higher temperatures. However, bearing performance will remain consistent.

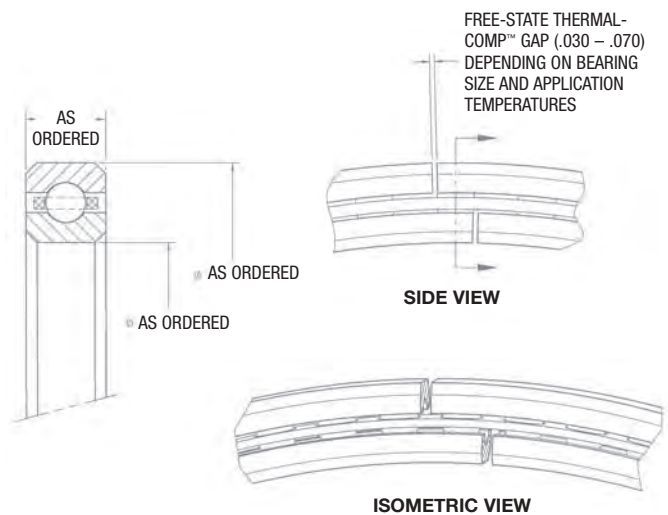

Thin section ball bearings are generally used in applications with space, weight, and load constraints. Some typical applications for standard RBC Thin Section Ball Bearings include:

- | | |
|--------------------------|-----------------------------|
| Radar Equipment | Machine Tools |
| Material Handling | Satellite Systems |
| Antenna Pedestals | Scanning Equipment |
| Aerospace | Slip Ring Assemblies |
| Optical Equipment | Harmonic Drives |
| Rotary Joints | Speed Reducers |
| Military Turrets | Robotics |

Lightweight Airborne Electro-Optical Imaging Equipment

This application requires bearings with combined load carrying capabilities and minimal added weight. A pair of angular contact RBC Thin Section Ball Bearings provides high stiffness and multiple load carrying capabilities in a compact, lightweight envelope.

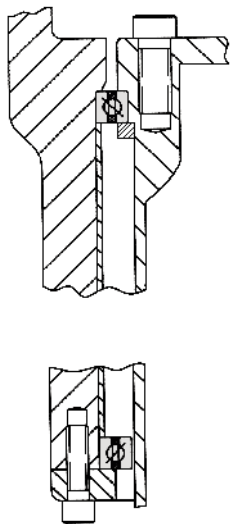
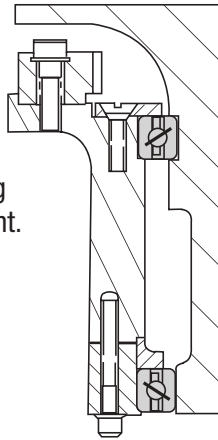

Rotary Joint

By using a pair of angular contact RBC Thin Section Ball Bearings, this design can carry radial, axial and moment loads.

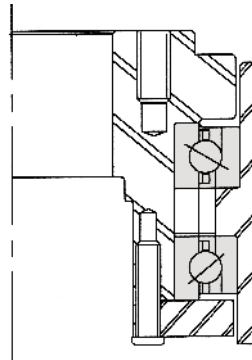

Direct Drive Assembly

A duplex pair of angular contact RBC Thin Section Ball Bearings provide the optimal load carrying capabilities in a compact design.

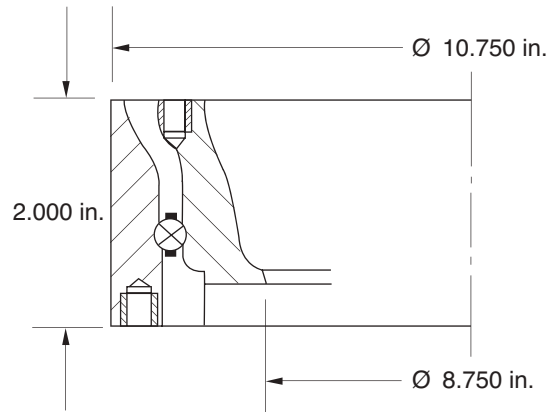

Aerial Camera Assembly

For use in an aerial camera assembly, an extra-light, low torque bearing was required. By redesigning a standard RBC Thin Section Ball Bearing 4-point contact design, the overall assembly weight was lowered from 7 lbs. to 3.8 lbs. In addition to weight reduction, this design, also reduced the running torque below 1 in.-lbs. with the starting torque below 2 in.-lbs.

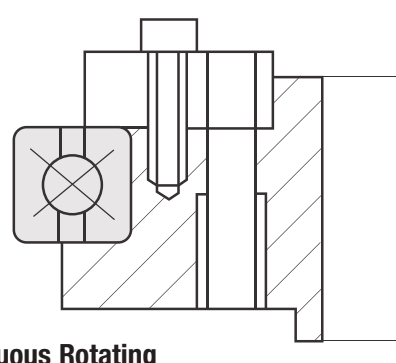

Continuous Rotating Machine Tool Table

Using a 4-point contact RBC Thin Section Ball Bearing provides stiffness for accurate positioning as well as carrying multiple loads. RBC supplied this assembly as shown.

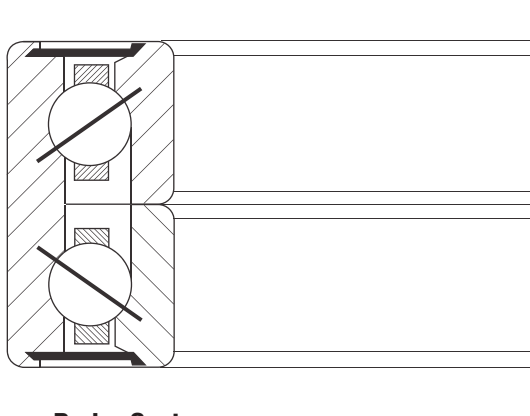

Airborne Radar System

A duplex pair of angular contact RBC Thin Section Ball Bearings was designed for an airborne radar system. This bearing application required combined load carrying capabilities, low temperature compatibility, and relatively low torque. Different from a standard Thin Section, this duplex bearing was designed with one outer ring and two inner rings with a slight preload. This design provided low torque and multiple loading capabilities.

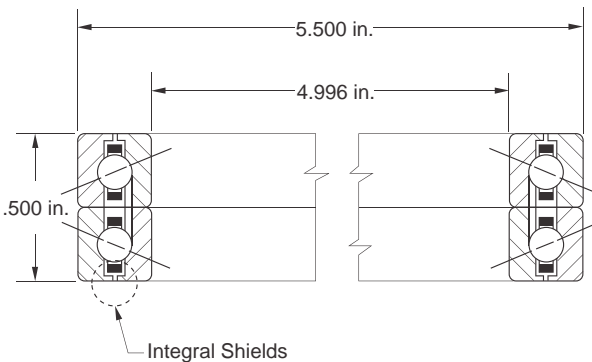

Instrument Gimbal Assembly

A preloaded duplex pair of angular contact RBC Thin Section Ball Bearings were designed to meet the low torque and corrosion resistant requirements in a combined load application. Designed for an instrument gimbal assembly in a missile, the duplex pair of bearings are subjected to combined radial, axial and moment loads. These special RBC Thin Section Ball Bearings have a light preload and were manufactured with integral shields as part of the rings.

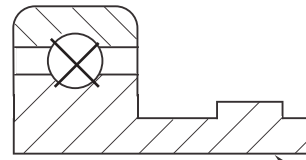

integral gear

Radar Antenna Drive

An RBC Thin Section Ball Bearing designed with a gear integrated with the inner ring, achieved both a significant weight reduction and improved accuracy as well as simplicity of assembly. This bearing is used in a radar antenna drive which has limited space available for its support bearing. Coil springs were used as spacers between balls to lower bearing torque and further reduce weight.

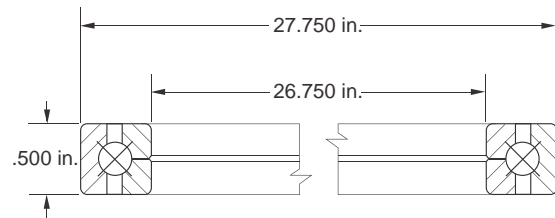

Aircraft Gun Turret

A bearing was required which would take radial, axial, and moment loading, to support an aircraft gun turret. It was desirable to have the bearing match the coefficient of expansion of the aluminum with a split inner ring and special balls to absorb shock and vibration loading. This bearing performed at 25% of the torque of the steel bearings previously used.

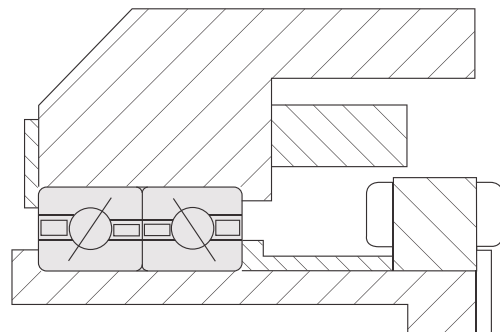

Airborne Turret Azimuth

A low torque, high stiffness, multiple load capacity, corrosion resistant bearing was required for an airborne turret azimuth drive assembly. For this application a duplexed pair of angular contact RBC Thin Section Ball Bearings was designed with toroid separators and stainless steel rings. This design maintained low torque, but still allowed multiple load carrying capabilities.

CUSTOM BEARING APPLICATIONS

EXTREME ANGULAR ACCURACY BEARINGS

Problem

The customer needed a set of bearings that maintained an extreme precise angular accuracy of the center line of the shaft to the housing. The angular accuracy requirement was a non-repeatable error ($\Delta\alpha$) of one arc second, and a repeatable error (α) of three arc seconds.

Recommendation

Bearings should be made to the most precise geometric tolerances possible. The bearings should be preloaded to overcome the minor surface imperfections of the balls and raceways. They should also be part of a cartridge incorporating the housing and shaft.

Solution

Bearings were made as part of the cartridge assembly and all angular measurements for accuracy were made relative to the housing and shaft. Bearings were preloaded and spaced axially to help overcome geometric inaccuracies of the bearing. The bearing raceways and balls were made from consumable electrode vacuum melted AISI 440C material. As the bearings had to operate in a vacuum, the separator material necessitated a special open weave phenolic material impregnated with a special silicone oil. To prevent migration of the oil from the cartridge assembly, the labyrinth seal was coated with a barrier film.

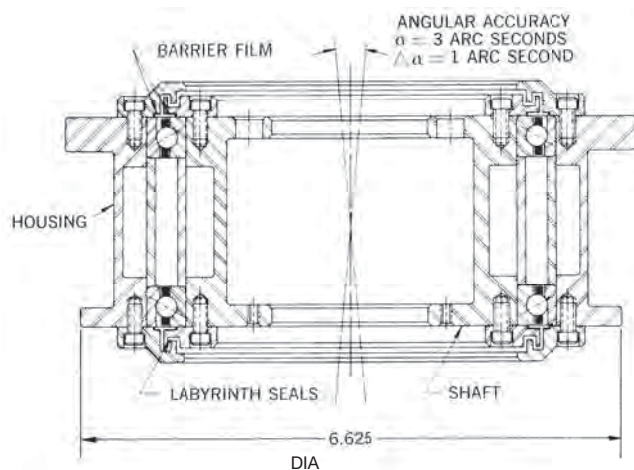

INTEGRAL BEARING ASSEMBLY

Problem

Save space and weight in an application involving a power take-off drive from a high speed gear box.

Recommendation

Make the races of the bearing integral with the housing and possibly with the gear shaft.

Solution

The bearing housing was designed to incorporate the outer raceway of the roller bearing and the outer raceway of the split inner race ball bearing. In order to increase the reliability of the rolling contact surfaces in the housing, the housing was manufactured from AISI M-50 material consumable electrode vacuum melted. The gear was made integral with the shaft which also contained the inner raceway of the roller bearing. The gear shaft was manufactured from consumable electrode vacuum melted AISI-9310 material; case hardened to Rc 61-64 on the gear tooth surface and in the roller bearing raceway. In order to facilitate lubrication of the bearings in the restricted area, lubrication holes were drilled through the housing into the space between the two bearings. The lubrication was fed through these holes from an annular groove in the housing.

The two halves of the split inner race were retained to the gear shaft by the use of a lock nut, clamping the races axially. The combined integral assembly of bearings, gear shaft and housing provided the desired space and weight reduction and gained improved operational accuracy. In addition, it afforded easier installation into the gear box.

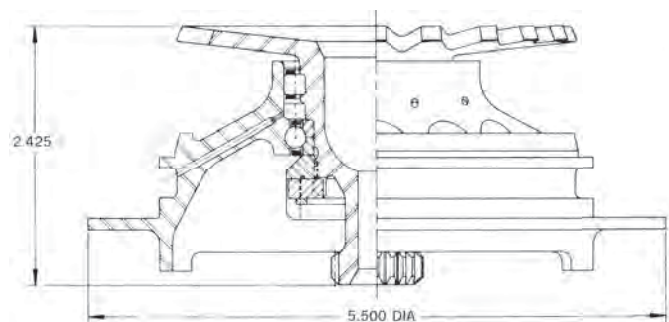

THIN SECTION GEARED BEARING

Problem

A radar antenna drive had only limited space available for its support bearings.

Recommendation

Use a thin section rather than a standard section radial ball bearing, thus achieving a significant weight reduction. Incorporate a gear as part of the inner ring to obtain improved accuracy and simplify the assembly.

Solution

The thin section bearing utilizes coil springs as spacers between the balls instead of a conventional separator to further reduce weight and lower bearing torque. The inner race of the bearing was extended and the gear was cut on this extended portion of the inner race. The incorporation of the gear into the inner race eliminated the necessity of a shaft clamping mechanism, etc., which would be required if the gear were separate from the bearing. Integrating the gear profile into the inner race increased the accuracy of the gear to bearing concentricity. The bearing was manufactured of the following materials: the balls and outer race are from AISI-440-material; the inner race manufactured from AISI-8620 material, carburized, and hardened in the raceway area to Rc 58-60.

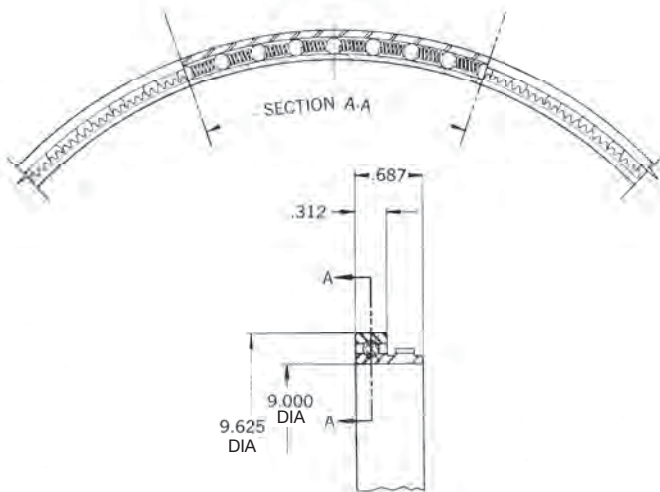

ROLLER, THRUST AND ANGULAR CONTACT BALL BEARING

Problem

A customer was trying to reduce costs of an existing hydraulic pump swash plate assembly.

Recommendation

Utilize an integral bearing assembly which combines a roller thrust bearing and an angular contact ball bearing.

Solution

The original swash plate design in the hydraulic pump utilized a roller thrust bearing to handle the thrust load and a separate angular contact radial ball bearing to handle radial loads and radially locate the swash plate assembly. The usage of two separate bearings required complex machining of the housing and swash plate with close control of tolerances, to eliminate excessive radial eccentricity of the swash plate assembly. In the original design, which utilized two separate bearings, it was necessary to mount the bearings axially adjacent to each other. The recommended bearing design decreased the axial space required for bearings, resulting in a size and weight savings. A combined bearing assembly is usually lower in cost than two separate bearings. The technique of integrating two bearings usually simplifies an assembly where two bearings had been utilized, or where problems have arisen relative to running accuracy, overall size or weight.

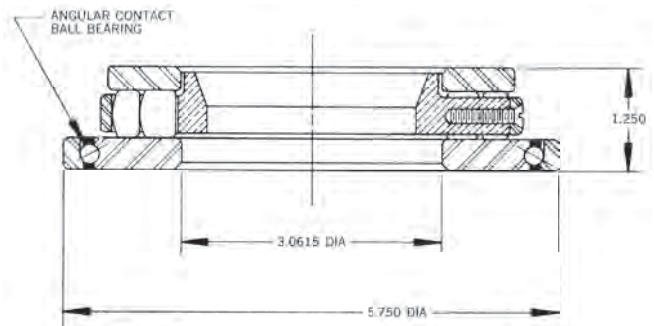

SELF-ALIGNING BEARING OPERATING IN LIQUID POLYETHYLENE

Problem

A rolling contact bearing was required on a vertical shaft which rotated in a catalytic-polyethylene autoclave. Blind assembly of the bearing and shaft which weighed approximately 10,000 pounds was necessary, due to the autoclave design.

Recommendation

Use radial ball bearing incorporating a self-aligning raceway made from corrosion resistant materials. The bearings should be capable of withstanding operating temperatures as high as 650°F, and capable of operating with liquid polyethylene as the lubricant.

Solution

The bearing was manufactured from AISI-440C material, specially heat treated to resist softening at high operating temperatures. The separator material was L-605 cobalt alloy which offered the necessary wear resistance.

To solve the client's problem of inserting the 18-foot-long assembly into a blind housing, a large lead-in chamfer was formed on the outside of the bearing. This lead-in chamfer allowed easy insertion of the bearing into the housing.

The previous bearing installation did not allow any shaft misalignment, resulting in bent shafts that were then unacceptable for further use. The self-aligning feature of the outer raceway permitted the bearing to misalign while rotating, allowing for shaft distortion as the shaft went through critical speeds.

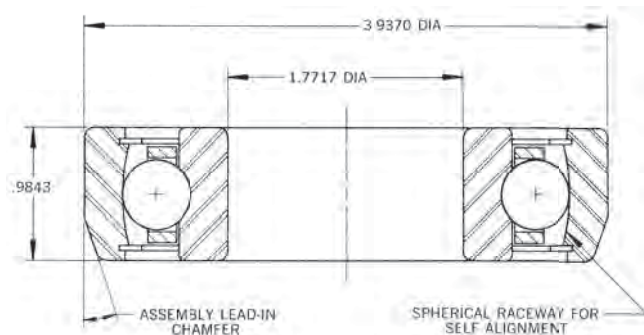

SENBAL BEARING

Problem

A fluidic gyroscope required a gimbaling, self-aligning bearing that would rotate at high speed. The bore of the bearing was to form part of the fluidic metering and sensing system.

Recommendation

Use a double row, self-aligning spherical ball bearing with spherical outer and inner raceways. The two rows of balls should be preloaded to obtain the running accuracy needed for the fluidic metering system in the bore of the bearing.

Solution

The double row spherical self-aligning ball bearing was designed with a removable portion of the spherical outer raceway to allow for preloading of the two rows of balls.

With the possibility of different rotational speeds of the two rows of balls, each row of balls had its own separator. To guide the separators, a special configuration was machined on the outside of the separator to allow for each separator to be guided at two points of contact with the spherical outer raceway.

The fluidic metering portion was made as a separate unit, press fitted into the bore of the bearing.

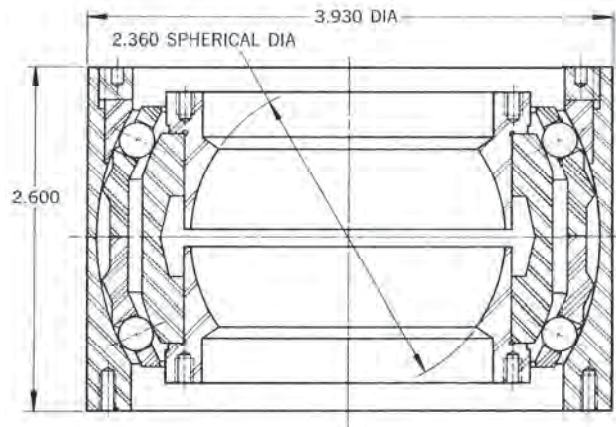

1200°F OSCILLATING BEARING

Problem

The customer required a high temperature rolling contact, oscillating bearing for operation at 1200°F, subjected to high vibration loads.

Recommendation

Design a rolling contact bearing with radial pre-load to overcome false brinelling that may occur in the high vibration environment. Bearings should be made from a corrosion resistant, high-temperature alloy.

Solution

The bearing was manufactured of Stellite® 6B material which was cold worked by an RBC proprietary process to obtain a hardness of Rockwell C-53 minimum in the raceway areas. The balls of this bearing were made from L-605 cobalt alloy. The bearing was of full complement design with a filling slot for insertion of the balls, and negative radial clearance of line to line to .0003 in. tight.

The lubricating film which is generated by the cobalt alloy races and balls permitted this bearing to operate without any additional lubricant. The increased hardness of the raceways to Rockwell C-53 minimum produced a bearing which was capable of operating up to 1200°F with extreme wear resistance.

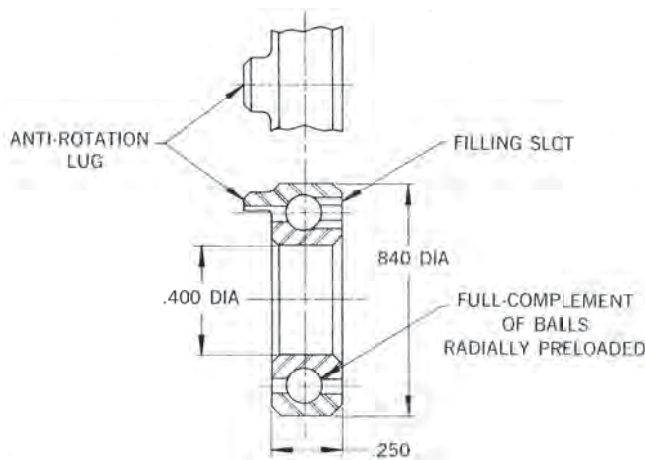

GEARBOX BEARINGS WITH SELF LUBRICATING SEPARATORS

Problem

Bearings were needed for operation in high-temperature gear boxes at 600°F to 650°F.

Conventional lubrication such as oil was not available, therefore, the bearings would have to be self-lubricating.

Recommendation

Use bearings of high-temperature, heat treated AISI-440C material. Incorporate in these bearings RBC-developed proprietary graphitic carbon separators, to act as the bearing lubricant.

Solution

Angular contact ball bearings were designed, utilizing an inner land guided separator of graphitic carbon material. The separator was reinforced on its outside diameter with a metallic shroud to withstand the centrifugal forces from high operating speeds and resist fracturing, which could result from the tremendous acceleration rate of the bearing rotation.

To facilitate a break-in period required for transfer of the self-lubricating material from the graphitic carbon separator to the rolling contact surfaces, the balls and raceways were coated with an impinged, tungsten-disulfide dry-film lubricant of approximately .000020 in.

in thickness. With the dry film lubricant on the raceways and balls, the bearings were capable of operating at the required speed without any break-in period normally required for bearings incorporating dry, self-lubricating separators.

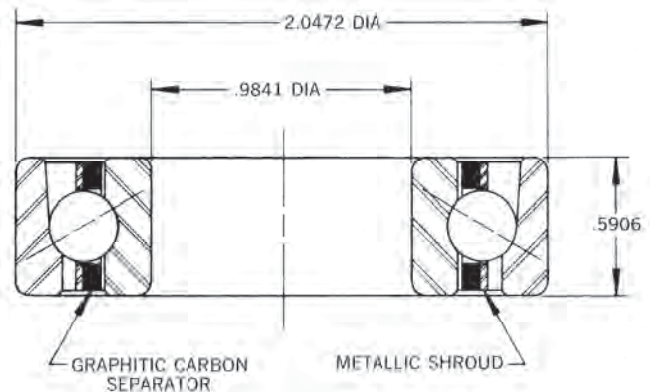

Stellite® is a registered trademark of KennaMetal Inc.

© 2008, 2011, 2018 RBC Bearings Incorporated. All rights reserved.

HIGH TEMPERATURE, ACTUATOR THRUST BEARINGS

Problem

A high temperature thrust bearing was needed to support the reactive thrust of a ball screw actuator. Bearings had to be capable of operating at approximately 850°F.

Recommendation

Use bearings of high temperature tool steel to withstand the applied loads at the high operating temperature.

Solution

Bearings were manufactured from CEVM M-2 tool steel with a full complement of sixteen .187 in. diameter tungsten carbide balls. The bearing was designed having a contact angle of 60° to handle the high thrust load and some radial loading.

The races were coated with a proprietary dry-film lubricant applied to the raceways of the bearings prior to installation of the bearing in the application.

The significant design feature which allows the bearings to operate at 850°F and at speeds up to 750 RPM without excessive wear is the combination of the tungsten carbide balls running against the M-2 tool steel raceways. Similar designs using M-2 tool steel balls had worn very rapidly at relatively short periods of application at the operating temperatures.

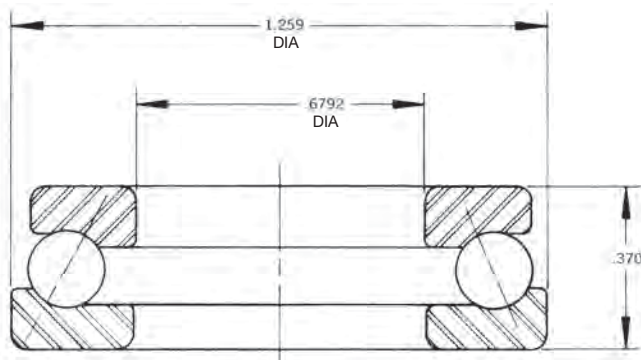

NON-MAGNETIC BEARING

Problem

A newly designed rotating magnetometer for ore analysis required a non-magnetic bearing.

Recommendation

Use a bearing with the raceways and balls made of a material capable of operating under the loads and possess the lowest magnetic permeability. The loading combined thrust, radial, and moment loads which required a duplex pair of bearings.

Solution

Manufactured the bearing from Berylco 25* material. This material was used for the inner and outer races, balls and shields. The separator was manufactured of a phenolic material.

The bearing was designed as a common outer duplex DB pair, lightly preloaded. To reduce contamination possibility, shields were incorporated. The bearing was lubricated by grease plating the raceways with MIL-PRF-23827 lubricant.

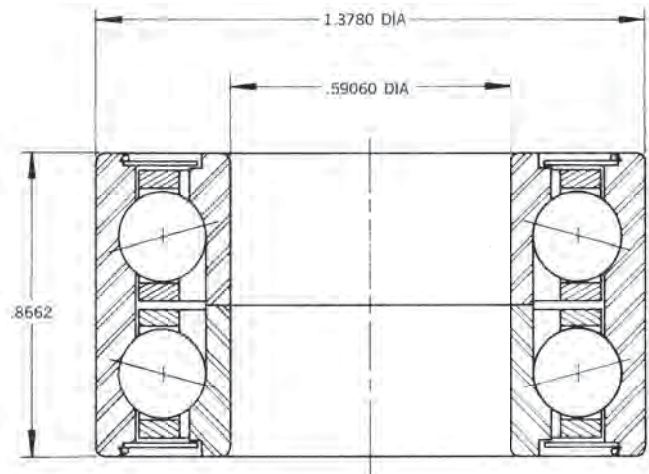

1400°F SELF-ALIGNING BALL BEARING

Problem

The customer needed a hinge bearing on the exhaust ducts of a jet engine used to propel and lift a ground effect vehicle machine.

Recommendation

Use a double row angular contact ball bearing in a self-aligning housing. Bearing materials to be made of corrosion and heat resistant material.

Solution

The double row ball bearing cartridge unit utilizes L-605 material for the raceway and balls. The bearing was mounted in a self-contained spherical housing to compensate for misalignment of the shaft during operation, which occurs due to temperature differentials between the frame and the exhaust nozzles.

The races were made by a special RBC-developed proprietary race hardening technique.

With this technique, the L-605 cobalt alloy material is work hardened and then heat treated to a Rockwell C-53 minimum.

The bearing operated for 50 hours with 1400°F exhaust gas passing through the bearing without any significant wear.

SPHERICAL, METAL-TO-METAL BEARINGS

Problem

A manufacturer of commercial aircraft required a landing gear support trunnion bearing.

Bearing must have low radial and axial clearances.

Recommendation

Use a metal-to-metal spherical plain bearing. It should have a dry-film lubricant on its spherical bearing surfaces. The bearing should be fabricated from corrosion resistant material.

Solution

With the clearances required, .0010/.0030 in. radial and .009 in. max. axial, assembly of match ground components was necessary. Swaging a bearing of this size would not result in reliable clearance control. The outer race was assembled to the ball by deforming it under radial pressure to an elliptical shape to allow the insertion of the ball. Once the ball is inserted, the pressure is removed from the outer race, allowing it to return to its original shape.

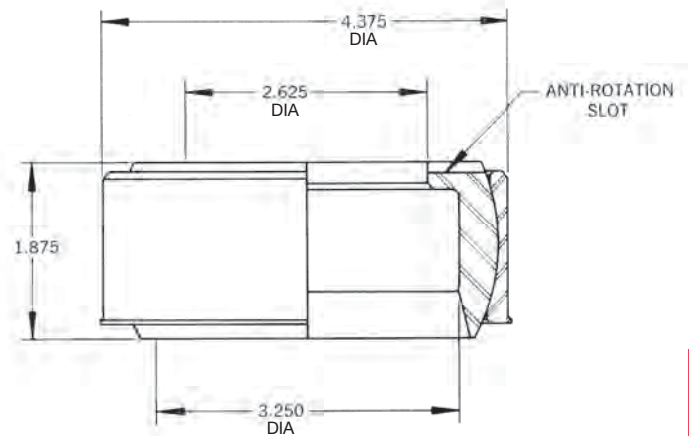
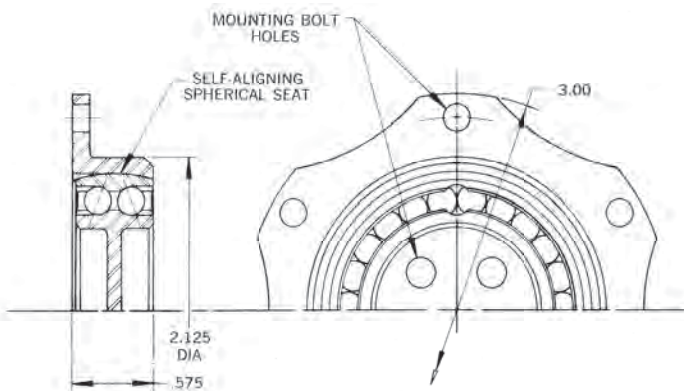

FOOD PROCESSING EQUIPMENT BEARINGS

Problem

Relatively short life was obtained on bearings made of 316 stainless steel in food processing equipment. 316 stainless steel was required to prevent contamination of the food products.

Recommendation

Use a harder, more wear resistant material that would still be resistant to the corrosive fluids of the processed food and prevent contamination.

Solution

A search of various materials that were resistant to the food products handled by this particular piece of equipment brought to light that certain cobalt alloys could be used without any fear of contamination or corrosion.

In order to increase the wear resistance of the cobalt alloys, they were cold worked in the raceways to increase the hardness and, thereby, increase the wear resistance.

The alloy used for the raceways and the balls was L-605. Separator material was 17-4PH.

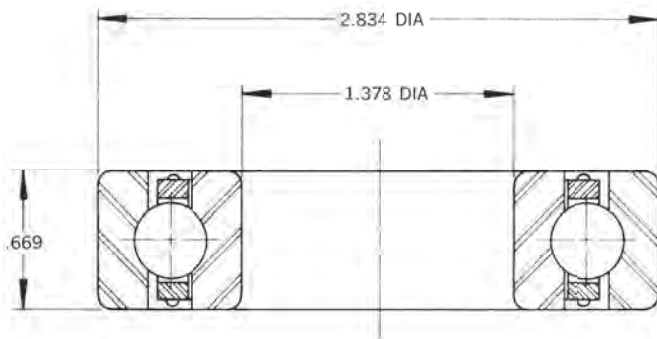

CHEMICAL PROCESSING EQUIPMENT BEARINGS

Problem

Bearings exposed to photographic-processing chemical solutions were failing. Bearings being used were made of AISI 440C material, sealed, and grease lubricated.

Recommendation

Use a bearing of a different alloy; make the separator self-lubricating and run the bearing in the chemical solutions.

Solution

The bearing used cobalt alloy balls and races and a self-lubricating separator of fiberglass reinforced TFE. To give additional strength to the riveted separator in this bearing, side plates of 300 series stainless steel were added to the separator.

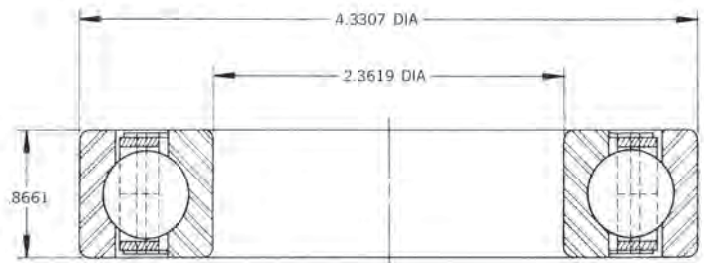

CRYOGENIC BEARINGS

Problem

The customer needed a high speed ball and roller bearings for use in cryogenic equipment. Bearings should also operate in cryogenic liquid or gaseous environment.

Recommendation

Use bearings of a corrosion resistant material such as AISI 440C and incorporate a self-lubricating material for the separators.

Solution

Ball and roller bearings of ABEC-5 tolerance grade were made of AISI 440C material, with special sub-zero treatment in liquid nitrogen. This sub-zero treatment gave the bearings the dimensional stability necessary for operating in cryogenic equipment.

The bearing separators were made of Teflon® reinforced fiberglass.

This basic bearing design criterion has been used in almost all liquid hydrogen and oxygen turbo pumps used in present day rocket engines.

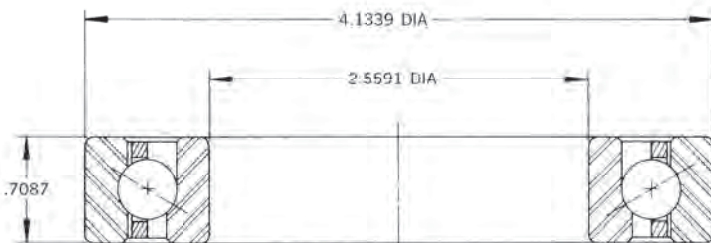

SELF-LUBRICATING MAIN SHAFT BEARING

Problem

The customer was looking for a mainshaft bearing for a vertical lift engine. For weight reduction, the bearing needed to be self-lubricating to eliminate a portion of the engine lubricating system.

Speed of the 85mm bore bearing was 16,000 RPM. The bearing, located in turbine end of the jet engine, accommodates axial shaft expansion.

Recommendation

Use a ball bearing with races and balls made from wear-resistant materials. Lubricate the bearing with a shrouded self-lubricating graphite separator. Make the inner race cylindrical to accommodate the axial shaft expansion.

Solution

Bearing was manufactured from CEM AISI-M50 material for the races and balls.

The separator of shrouded graphite was outer land guided on two graphite rings, pressed into the outer race ring.

To prevent damage to the graphite while inserting the shaft into the bearing, a side plate was added that prevented any accidental contact of the shaft with the graphite separator. To allow for the excess graphite to purge from the bearing, holes were put in the protective side plate.

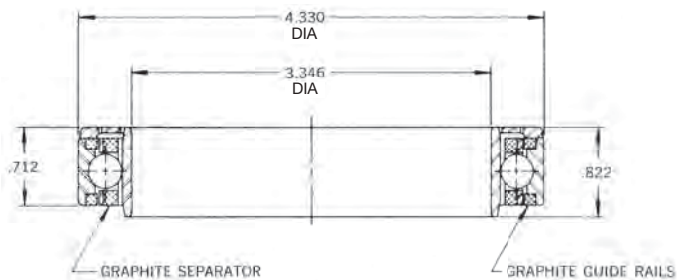

Teflon® is a registered trademark of DuPont.

© 2008, 2011, 2018 RBC Bearings Incorporated. All rights reserved.

NUCLEAR REACTOR BEARING

Problem

The application called for a bearing to accommodate the thrust load in a control rod drive mechanism. The bearing is lubricated with chemically pure water, de-ionized, and de-oxygenated.

Recommendation

Use a double row ball bearing, tandem ground for thrust sharing to obtain the life required. Because radial support of the inner race is marginal, the inner race for both rows should be ground on the same ring.

Solution

The double row ball bearing was made of cobalt alloy materials, and the separator of 17-4PH.

To obtain the maximum capacity in this double gothic arch thrust bearing, the outer races are split, permitting the maximum quantity of balls in each row. Thrust sharing of two rows is accomplished by accurate match grinding of the spacer ring to fit the gap between the outer races, and by matching the contact angle in both rows equal within two degrees.

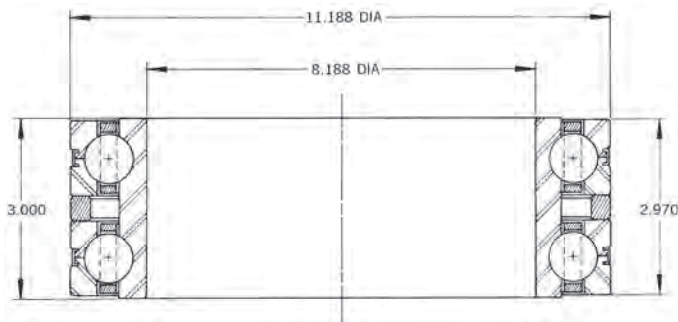

BALL BEARINGS FOR VACUUM OPERATION

Problem

The customer wanted a high speed ball bearing, to run at temperatures up to 1000°F.

Recommendation

Use bearing of wear resistant, high temperature tool steel. Bearing lubricant should be dry and not sublimate.

Solution

The bearings were made of T-5 tool steel which has high hardness and wear resistance at 1000°F. The bearings contain a full complement of balls and no separator.

The lubricant was an ultra-thin layer of silver deposited on the balls. The bearings were manufactured without any snap, which may abrade the silver on the balls.

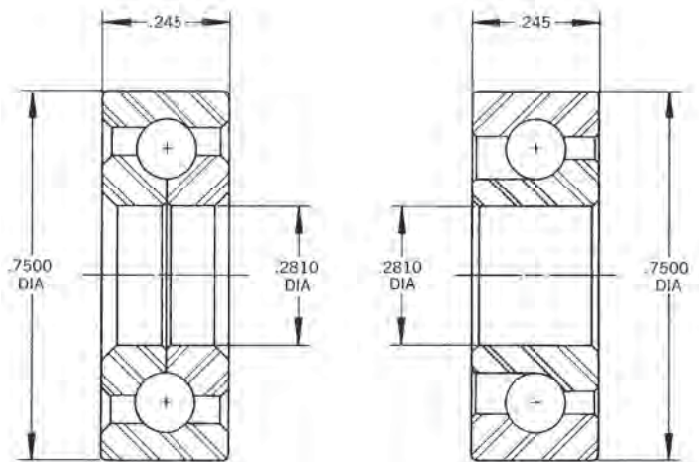

TURBO-MACHINERY ROLLER BEARING

Problem

A high speed mainshaft roller bearing was failing due to skidding. Insufficient load on the bearing was the cause.

Recommendation

Use a preloaded roller bearing to overcome the skidding problem.

Solution

The roller bearing was designed with hollow rollers, providing a radial internal pre-load between the inner and outer races.

The bearing has an inner land guided separator. The viscous drag between the separator and the inner race land diameter promotes the rotation of the separator.

To provide for cooling the inner race, under race cooling grooves were located in the bore of the inner race.

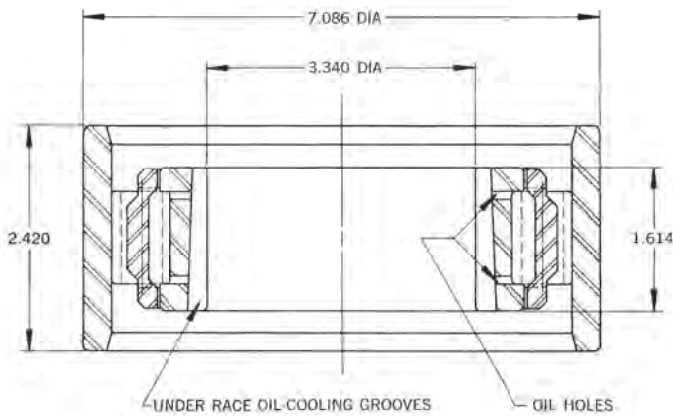

DRUSBA BEARING

Problem

A large diameter bearing to support a platform. The platform and portion of the bearing operate in an anisotropic quantum electrodynamic field, while in a vacuum.

Recommendation

A 4-point contact preloaded ball bearing was recommended. Provide means for heat addition or removal to maintain the desired pre-load. Temperature variations occur due to the field; the outer ring normally has a higher temperature than the inner ring.

Solution

A split outer race, full-complement ball bearing to be made of Cobenium rings, and sodium filled Cobenium balls. The raceways and balls were gold plated. The gold is the lubricant.

The inner ring of the bearing contains heating or cooling chambers. These are formed by electron beam welding the annular members to the ring. The fluid flowing through the chambers is controlled relative to rate of flow and temperature, depending upon the specific race area temperature serviced by that chamber. This permits control of the geometric configuration of the inner race and pre-load.

The sodium filled balls are used for heat transfer between the rings.

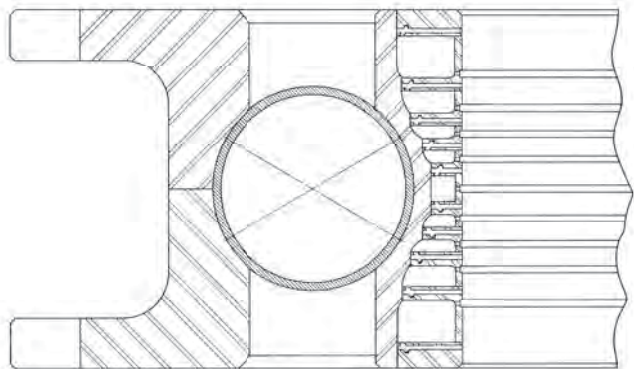

CUSTOM BEARING APPLICATIONS

WATER-LUBRICATED BEARINGS

Problem

Long-life, wear-resistant bearings for running in water.

Recommendation

Use bearings of cobalt alloys for maximum corrosion and wear resistance. Design the bearing with race curvatures and clearances to compensate for the lack of lubricity of the water.

Solution

Bearing rings were made of L-605 cobalt alloy. An RBC-developed cold working technique was used to increase the hardness of the alloy to Rc 53 minimum after heat treatment, for increased wear resistance. Normal cold worked and heat treated hardness of this alloy is Rc 47.

The separators in the bearings were made from 17-4PH corrosion resistant material, heat treated to increase wear resistance.

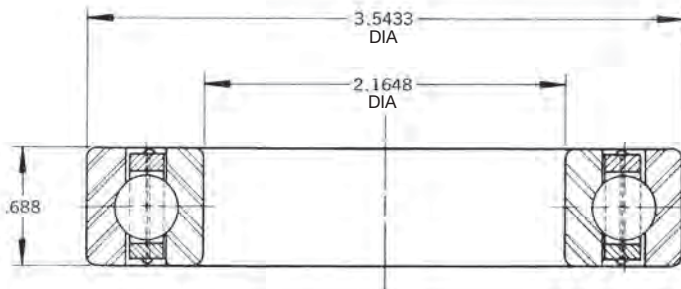

OPTICAL PRECISION BEARINGS

Problem

The customer wanted to support a 14 in. diameter rotating tube that contained lenses. Minimal radial runout was required to prevent distortion of the image by the lenses. Bearings should be low in torque and corrosion resistant, pre-lubricated, and suitable for a vacuum operation.

Recommendation

The rotating tube should be supported with duplex pairs of bearings, DB mounted, preloaded, with minimal lubrication of a low vapor pressure lubricant.

Solution

Duplex DB pair of bearings, preloaded, were manufactured of passivated AISI 440C corrosion resistant steel.

The radial and axial runouts were held to the following: radial runout, inner, .0002 T.I.R.; outer, .0003 T.I.R.; axial runout, inner, .0002 T.I.R.; outer, .0003 T.I.R. The separator consisted of TFE separator around alternate balls for low starting and running torque.

Bearings were lubricated with a special lubricant and then centrifuged at 100 g's for 10 minutes to remove the excess oil.

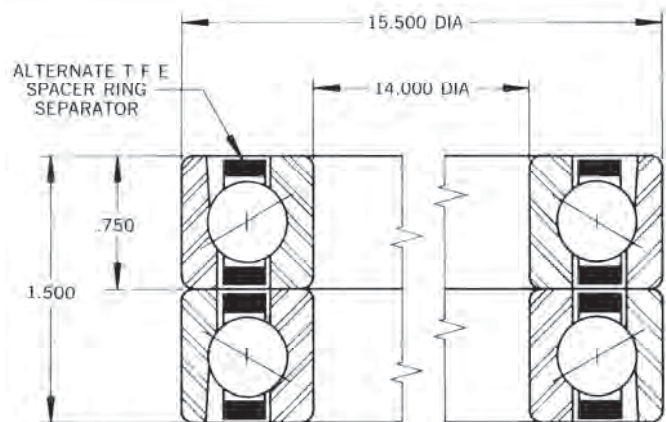

CAMERA MOUNT BEARING

Problem

There was a need for a lightweight, low torque bearing for use in an aerial camera assembly.

Recommendation

Use a bearing with rings made of aluminum, and hard anodize the raceway areas.

Solution

The original steel bearing design — a double row angular contact ball bearing in an aluminum housing — was replaced with a single row, 4-point contact bearing, with the rings manufactured of 7075-T-651 aluminum. The raceways of both rings were hard anodized and ground after hard anodizing. Balls were of passivated AISI 440C.

This construction utilizing the aluminum material, reduced the overall weight of the bearing assembly from over 7 lbs. in the original design to 3.8 lbs. in the finished unit.

In order to obtain a low running and starting torque, alternate balls in the raceway were surrounded with TFE separator and the raceways were grease-plated. The bearing running torque was below 1 inch lbs. with the starting torque being below 2 inch lbs.

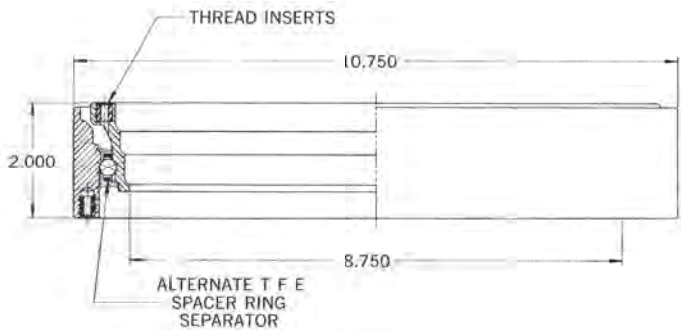

TURBO-MACHINERY BALL BEARING

Problem

A ball bearing running at 2.2 million DN*, with no load, was failing due to the fatigue of the outer race, and ball skidding. Fatigue failures had been occurring due to the large number of stress cycles, caused solely by the centrifugal force of the balls.

Recommendation

Reduce the number of balls in the bearing, thereby reducing the number of stress cycles on the outer race.

Make the separator a lightweight steel design. Reduction of the separator and ball mass would reduce the inertial resistance, thereby reducing skidding. Change material from AISI-52100 to a tool steel to increase resistance to skid damage.

Solution

Bearing races and balls were made from CEVM AISI-M50 tool steel. The separator was manufactured from AISI-4340 material, hardened to Rc 26-32 and silver plated.

The number of balls was reduced from twenty to eight balls, reducing the number of stress cycles by sixty percent.

The separator configuration permitted an increase of lubricant flow through the bearing for cooling and lubrication.

*DN = D, bearing bore in (mm) - N, shaft speed in (RPM).

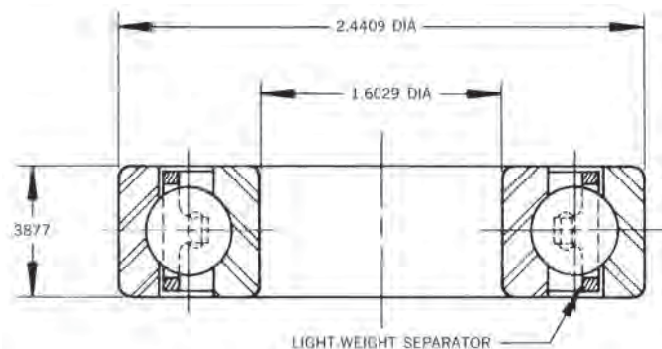

CUSTOM BEARING APPLICATIONS

Helicopter Applications

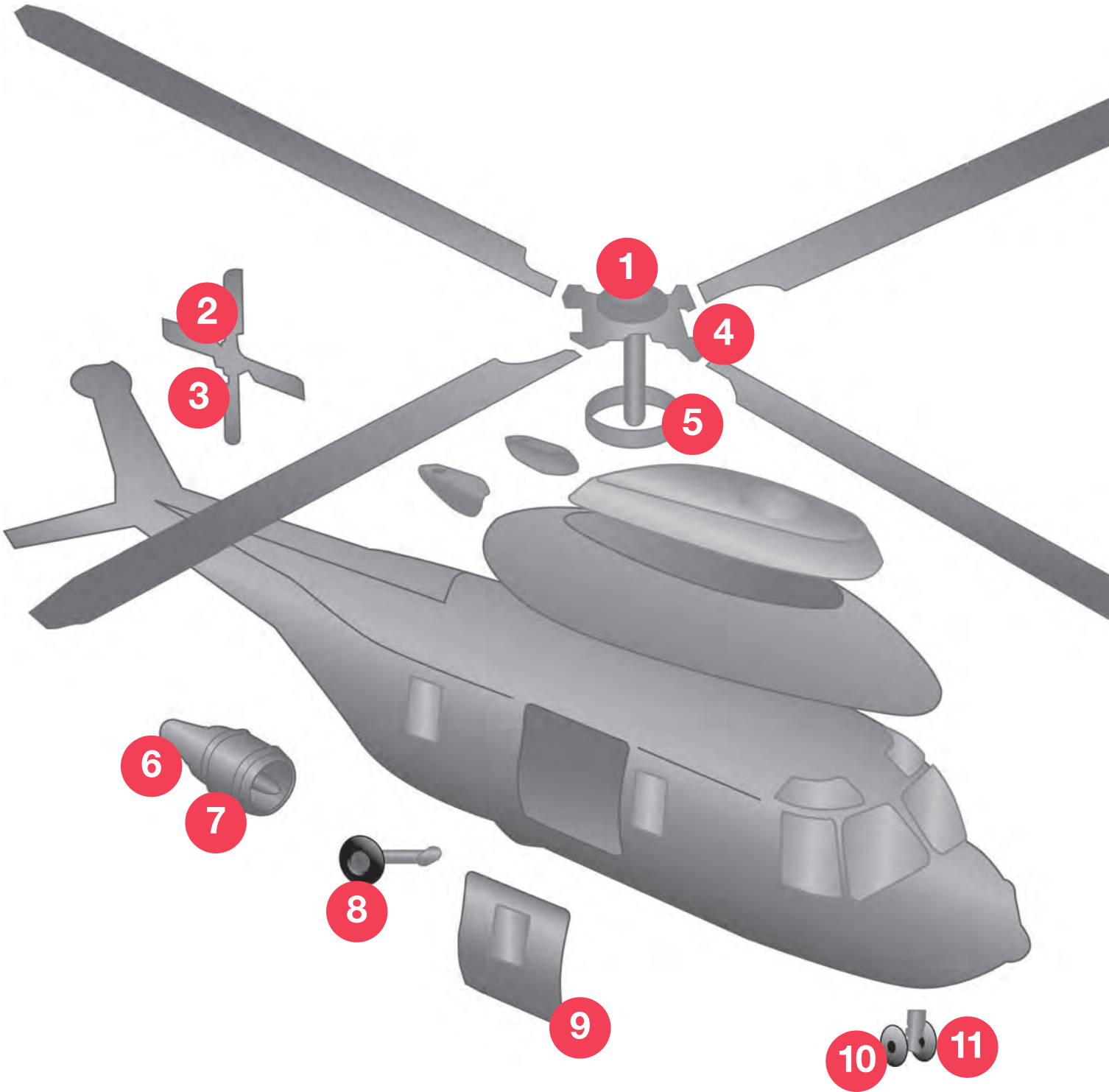



1. Main Rotor Bearings



5. Main Rotor Swashplate Slider Bearings

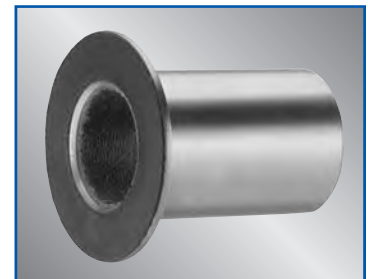

9 & 10. Self-lubricating Bushings for Doors and Landing Gear



2. Tail Rotor Pitch Link Bearings



6. Engine Gear Box and Transmission Bearings



11. Landing Gear Bearings

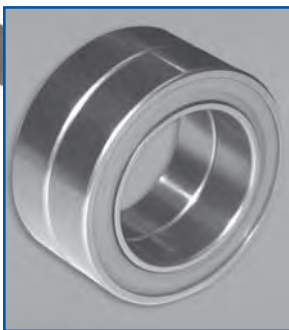

3. Tail Rotor Bearings



7 & 8. Rod Ends, Sphericals, and Journal Bearings for Landing Gear and Engines



4. Main Rotor Pitch Link Bearings

Airframe Applications

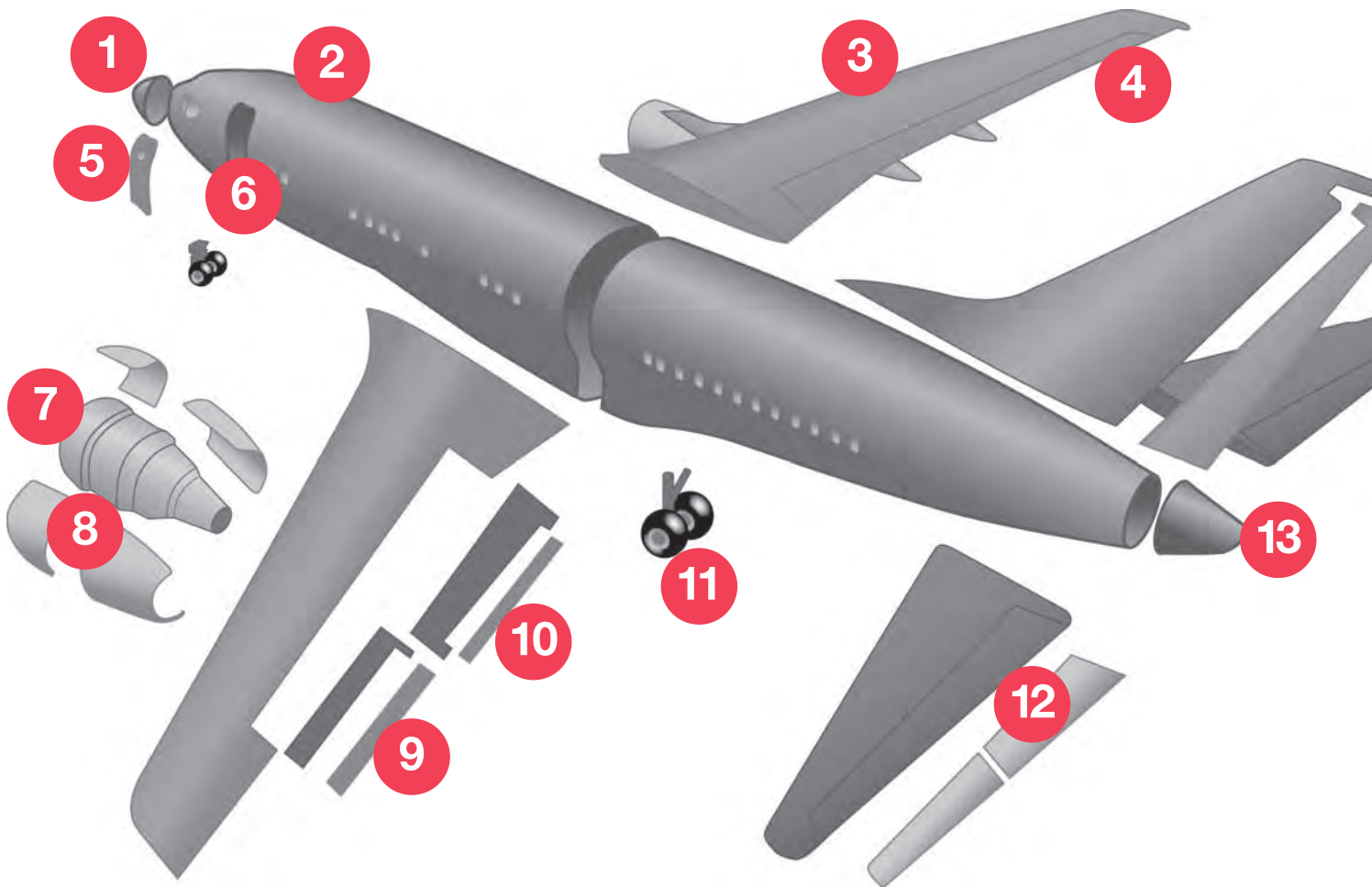

1. Radar Gimbal Thin Section Bearings



2. Stowage Bin Support Bearings



3. Airframe Control Bearings

© 2008, 2011, 2018 RBC Bearings Incorporated. All rights reserved.



4. Spherical Plain and Ball Bearing Rod Ends used in Actuator and Aircraft Control Linkages



7. Engine Bearings

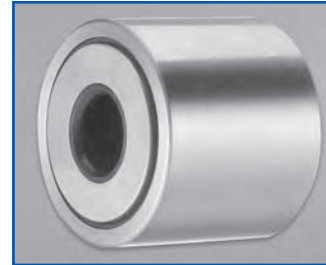

10. Track Rollers

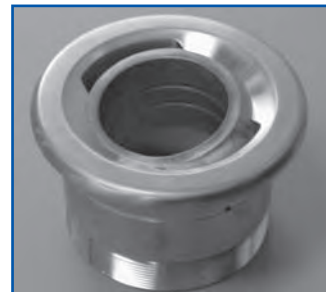

11. Landing Gear Trunnion Bearings



5. Door Locking Mechanism and Landing Gear Bushings, Actuator Bearings



8. Thrust Reverser Linkage Bearings



12. Horizontal Stabilizer Bearings



6. Door Linkage Bearings



9. Ball and Roller Rod Ends used on Control Surfaces



13. APU Bearings

CONVERSION TABLES

TO CONVERT FROM TO MULTIPLY BY

Acceleration
 foot/second²meter/second²m/s²0.3048
 inch/second²meter/second²m/s²0.0254

Area
 foot²meter²m²0.09290304
 inch²meter²m²0.00064516
 inch²millimeter²mm²645.16
 yard²meter²m²0.836127
 mile² (U.S. statute)meter²m²2589988

Bending Moment or Torque
 dyne-centimeternewton-meterN · m0.0000001
 kilogram-force-meternewton-meterN · m9.806650
 pound-force-inchnewton-meterN · m0.1129848
 pound-force-footnewton-meterN · m1.355818

Energy
 B.T.U. (International Table)jouleJ1055.056
 foot-pound-forcejouleJ1.355818
 kilowatt-hourmegajouleMJ3.6

Force
 kilogram-forcenewtonN9.806650
 kilopond-forcenewtonN9.806650
 pound-force (lbf avoirdupois)newtonN4.448222

Length
 fathommeterm1.8288
 footmeterm0.3048
 inchmillimetermm25.4
 microinchmicrometerum0.0254
 micron (µm)millimetermm0.0010
 mile (U.S. statute)meterm1609.344
 yardmeterm0.9144
 nautical mile (UK)meterm1853.18

Mass
 Kilogram-force-second²/meter (mass)kilogramkg9.806650
 kilogram-masskilogramkg1.0
 pound-masskilogramkg0.4535924
 ton (long, 2240 lbm)kilogramkg1016.047
 ton (short, 2000 lbm)kilogramkg907.1847
 tonnekilogramkg1000.000

Power
 B.T.U. (International Table)/hourwattW0.293071
 B.T.U. (International Table)/minutewattW17.58426
 horsepower (550 ft lbf/s)kilowattkW0.745700
 B.T.U. (thermochemical)/minutewattW17.57250

Pressure or Stress (Force/Area)
 newton/meter²pascalPa1.0000
 kilogram-force/centimeter²pascalPa98066.50
 kilogram-force/meter²pascalPa9.806650
 kilogram-force/millimeter²pascalPa9806650
 pound-force/foot²pascalPa47.88026
 pound-force/inch² (psi)megapascalMPa0.006894757

Temperature
 degree Celsiusdegree Kelvin°Kt_k = t_c + 273.15
 degree Fahrenheitdegree Kelvin°Kk = 5/9 (t_f + 459.67)
 degree Fahrenheitdegree Celsius°Ct_c = 5/9 (t_f - 32)

Velocity
 foot/minutemeter/secondm/s0.00508
 foot/secondmeter/secondm/s0.3048
 inch/secondmeter/secondm/s0.0254
 kilometer/hourmeter/secondm/s0.27778
 mile/hour (U.S. statute)meter/secondm/s0.44704
 mile/hour (U.S. statute)kilometer/hourkm/h1.609344

Volume
 foot³meter³m³0.02831685
 gallon (U.S. liquid)literl3.785412
 litermeter³m³0.001
 inch³meter³m³0.00001638706
 inch³centimeter³cm³16.38706
 inch³millimeter³mm³16387.06
 ounce (U.S. fluid)centimeter³cm³29.57353
 yard³meter³m³0.7645549

VISCOSITY CONVERSION TABLE

SUS Saybolt (sec.)	R' Redwood (sec.)	E Engler (deg.)	cSt Centistokes
35	32.2	1.18	27
40	36.2	1.32	4.3
45	40.6	1.46	59
50	44.9	1.60	7.4
55	49.1	1.75	8.9
60	53.5	1.88	10.4
65	57.9	2.02	11.8
70	62.3	2.15	13.1
75	67.6	2.31	14.5
80	71.0	2.42	15.8
85	75.1	2.55	17.0
90	79.6	2.68	18.2
95	84.2	2.81	19.4
100	88.4	2.95	20.6
110	97.1	3.21	23.0
120	105.9	3.49	25.0
130	114.8	3.77	27.5
140	123.6	4.04	29.8
150	132.4	4.32	32.1
160	141.1	4.59	34.3
170	150.0	4.88	36.5
180	158.8	5.15	38.8
190	167.5	5.44	41.0
200	176.4	5.72	43.2
220	194.0	6.28	47.5
240	212	6.85	51.9
260	229	7.38	56.5
280	247	7.95	60.5
300	265	8.51	64.9
325	287	9.24	70.3
350	309	9.95	75.8
375	331	10.7	81.2
400	353	11.4	86.8
425	375	12.1	92.0
450	397	12.8	97.4
475	419	13.5	103
500	441	14.2	108
550	485	15.6	119
600	529	17.0	130
650	573	18.5	141
700	617	19.9	152
750	661	21.3	163
800	705	22.7	173
850	749	24.2	184
900	793	25.6	195
950	837	27.0	206
1000	882	28.4	217
1200	1058	34.1	260
1400	1234	39.8	302
1600	1411	45.5	347
1800	1587	51	390
2000	1763	57	433
2500	2204	71	542
3000	2646	85	650
3500	3087	99	758
4000	3526	114	867
4500	3967	128	974
5000	4408	142	1082
5500	4849	156	1150
6000	5290	170	1300
6500	5730	185	1400
7000	6171	199	1510
7500	6612	213	1630
8000	7053	227	1740
8500	7494	242	1850
9000	7934	256	1960
9500	8375	270	2070
10000	8816	284	2200

INCHES TO MILLIMETERS - UNITS

Inches		0	1	2	3	4	5	6	7	8
0	0.0000	0.000	25.400	50.800	76.200	101.600	127.000	152.400	177.800	203.200
1/16	0.0625	1.588	26.988	52.388	77.788	103.188	128.588	153.988	179.388	204.788
1/8	0.1250	3.175	28.575	53.975	79.375	104.775	130.175	155.575	180.975	206.375
3/16	0.1875	4.763	30.162	55.562	80.962	106.362	131.762	157.162	182.562	207.962
1/4	0.2500	6.350	31.750	57.150	82.550	107.950	133.350	158.750	184.150	209.550
5/16	0.3125	7.938	33.338	58.738	84.138	109.538	134.938	160.338	185.735	211.138
3/8	0.3750	9.525	34.925	60.325	85.725	111.125	136.525	161.925	187.325	212.725
7/16	0.4375	11.112	36.512	61.912	87.312	112.712	138.112	163.512	188.912	214.312
1/2	0.5000	12.700	38.100	63.500	88.900	114.300	139.700	165.100	190.500	215.900
9/16	0.5625	14.288	39.688	65.088	90.488	115.888	141.288	166.688	192.088	217.488
5/8	0.6250	15.875	41.275	66.675	92.075	117.475	142.875	168.275	193.675	219.075
11/16	0.6875	17.462	42.862	68.262	93.662	119.062	144.462	169.862	195.262	220.662
3/4	0.7500	19.050	44.450	69.850	95.250	120.650	146.050	171.450	196.850	222.250
13/16	0.8125	20.638	46.038	71.438	96.838	122.238	147.638	173.038	198.438	223.838
7/8	0.8750	22.225	47.625	73.025	98.425	123.825	149.225	174.625	200.025	225.425
15/16	0.9375	23.812	49.212	74.612	100.012	125.412	150.812	176.212	201.612	227.012

Inches		9	10	11	12	13	14	15
0	0.0000	228.600	254.000	279.400	304.800	330.200	355.600	381.000
1/16	0.0625	230.188	255.588	280.988	306.388	331.788	357.188	382.588
1/8	0.1250	231.775	257.175	282.575	307.975	333.375	358.775	384.175
3/16	0.1875	233.362	258.762	284.162	309.562	334.962	360.362	385.762
1/4	0.2500	234.950	260.350	285.750	311.150	336.550	361.950	387.350
5/16	0.3125	236.538	261.938	287.338	312.738	338.138	363.538	388.938
3/8	0.3750	238.125	263.525	288.925	314.325	339.725	365.125	390.525
7/16	0.4375	239.712	265.112	290.512	315.912	341.312	366.712	392.112
1/2	0.5000	241.300	266.700	292.100	317.500	342.900	368.300	393.700
9/16	0.5625	242.888	268.288	293.688	319.088	344.488	369.888	395.288
5/8	0.6250	244.475	269.875	295.275	320.675	346.075	371.475	396.875
11/16	0.6875	246.062	271.462	296.862	322.262	347.662	373.062	398.462
3/4	0.7500	247.650	273.050	298.450	323.850	349.250	374.650	400.050
13/16	0.8125	249.238	274.638	300.038	325.438	350.838	376.238	401.638
7/8	0.8750	250.825	276.225	301.625	327.025	352.425	377.825	403.225
15/16	0.9375	252.412	277.812	303.212	328.612	354.012	379.412	404.812

B.S.I. Norm No. 350 } 1 inch = 25.400 mm
A.S.A. Norm No. B48.1 } (exact)

DIN 4890, 1mm = $\frac{1}{25.4}$ inches

UNITS

Inches	10	
0	—	254
1	25.4	279.4
2	50.8	304.8
3	76.2	330.2
4	101.6	355.6
5	127	381
6	152.4	406.4
7	177.8	431.8
8	203.2	457.2
9	228.6	482.6

FRACTIONS

1/10"		1/100"		1/1000"		1/10000"	
Inches	mm	Inches	mm	Inches	mm	Inches	mm
0.1	2.54	0.01	0.254	0.001	0.0254	0.0001	0.00254
0.2	5.08	0.02	0.508	0.002	0.0508	0.0002	0.00508
0.3	7.62	0.03	0.762	0.003	0.0762	0.0003	0.00762
0.4	10.16	0.04	1.016	0.004	0.1016	0.0004	0.01016
0.5	12.70	0.05	1.270	0.005	0.1270	0.0005	0.01270
0.6	15.24	0.06	1.524	0.006	0.1524	0.0006	0.01524
0.7	17.78	0.07	1.778	0.007	0.1778	0.0007	0.01778
0.8	20.32	0.08	2.032	0.008	0.2032	0.0008	0.02032
0.9	22.86	0.09	2.286	0.009	0.2286	0.0009	0.02286

MILLIMETERS TO INCHES - UNITS

mm	10	20	30	40	50	60	70	80	90	
0	—	0.39370	0.78740	1.18110	1.57480	1.96850	2.36220	2.75591	3.14961	3.54331
1	0.03937	0.43307	0.82677	1.22047	1.61417	2.00787	2.40157	2.79528	3.18898	3.58268
2	0.07874	0.47244	0.86614	1.25984	1.65354	2.04724	2.44094	2.83465	3.22835	3.62205
3	0.11811	0.51181	0.90551	1.29921	1.69291	2.08661	2.48031	2.87402	3.26772	3.66142
4	0.15748	0.55118	0.94488	1.33858	1.73228	2.12598	2.51969	2.91339	3.30709	3.70079
5	0.19685	0.59055	0.98425	1.37795	1.77165	2.16535	2.55906	2.95276	3.34646	3.74016
6	0.23622	0.62992	1.02362	1.41732	1.71102	2.20472	2.59843	2.99213	3.38583	3.77953
7	0.27559	0.66929	1.06299	1.45669	1.85039	2.24409	2.63780	3.03150	3.42520	3.81890
8	0.31496	0.70866	1.10236	1.49606	1.88976	2.28346	2.67717	3.07087	3.46457	3.85827
9	0.35433	0.74803	1.14173	1.53543	1.92913	2.32283	2.71654	3.11024	3.50394	3.89764

mm	100	200	300	
0	—	3.93701	7.87402	11.81100
10	0.39370	4.33071	8.26772	12.20470
20	0.78740	4.72441	8.66142	12.59840
30	1.18110	5.11811	9.05512	12.99210
40	1.57480	5.51181	9.44882	13.38580
50	1.96850	5.90551	9.84252	13.77950
60	2.36220	6.29921	10.23620	14.17320
70	2.75591	6.69291	10.62990	14.56690
80	3.14961	7.08661	11.02360	14.96060
90	3.54331	7.48031	11.41730	15.35430

FRACTIONS

1/10 mm		1/100 mm		1/1000 mm	
mm	inches	mm	inches	mm	inches
0.1	0.00394	0.01	0.00039	0.001	0.000039
0.2	0.00787	0.02	0.00079	0.002	0.000079
0.3	0.01181	0.03	0.00118	0.003	0.000118
0.4	0.01575	0.04	0.00157	0.004	0.000157
0.5	0.01969	0.05	0.00197	0.005	0.000197
0.6	0.02362	0.06	0.00236	0.006	0.000236
0.7	0.02756	0.07	0.00276	0.007	0.000276
0.8	0.03150	0.08	0.00315	0.008	0.000315
0.9	0.03543	0.09	0.00354	0.009	0.000354

RBC Aerospace Bearing Products

RBC Bearings Incorporated has been producing bearings in the USA since 1919. RBC offers a full line of aerospace bearings, including unique custom configurations.



Spherical Bearings

- MS approved to AS81820 (formerly MIL-B-81820)
- Boeing and Airbus approved
- Self-lubricating • Metal-to-Metal
- Loader slots • High temperature
- Low coefficient of friction
- Special configurations and materials



Rod End Bearings

- MS approved to AS81935 (formerly MIL-B-81935)
- Boeing and Airbus approved
- Self-lubricating • Metal-to-Metal
- Loader slots • High temperature
- Low coefficient of friction
- Special configurations and materials



Thin Section Ball Bearings

- Standard cross-sections to one inch
- Stainless steel and other materials are available • Sizes to 40 inches
- Seals available on all sizes and standard cross-sections
- Super duplex configurations



Cargo Roller Bearings

- Boeing approved
- Features precision ground, semi-ground, and unground ball bearings
- Offered in caged and full complement configurations



Journal Bearings

- MS approved to AS81934 (formerly MIL-B-81934)
- Boeing and Airbus approved
- Plain and flanged • Self-lubricating
- High temperature • High loads
- Available in inch and metric sizes



Track Rollers

- MS approved to AS39901 (formerly MIL-B-3990)
- Boeing and Airbus approved
- ATF single row and ATL double row
- Sealed with lube holes and grooves
- Heavy duty cross-sections
- Advanced AeroCres® materials available
- Lined track rollers available

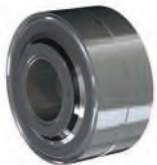

Double Row Hourglass Bearings

- Boeing approved
- High Radial and Axial Load Ratings
- Low Torque
- Integral Swage Grooves Available
- Pyrowear®, Cronidur30®, 52100, 9310 or 440C



Cam Followers

- MS approved to AS39901 (formerly MIL-B-3990)
- Advanced AeroCres® materials available
- Maximum corrosion resistance
- Superior lubricants and seals to reduce maintenance



Airframe Control Ball Bearings

- MS approved to AS7949 (formerly MIL-B-7949)
- Boeing and Airbus approved
- Single and double row
- Radial, self-aligning, and pulley series
- 52100 Cad plated and 440C stainless



Load Slot Bearings

- Spherical and rod end designs
- Superior ball-to-race conformity
- Reduced maintenance cost
- Variety of race materials available
- Boeing approved



Ball Bearing Rod Ends

- MS approved to AS6039 (formerly MIL-B-6039) • Boeing approved
- Various shank configurations
- Low coefficient of friction
- Advanced AeroCres® materials available



Specials

- Many specialty bearings, custom-designed and configured for diverse aerospace applications
- Capability for advanced aerospace specialty corrosion resistant and high temperature materials



Innovation. Commitment. Quality.

www.rbcbearings.com

This document contains a general overview of the products and features described herein. It is solely for informational purposes, does not represent a warranty of the information contained herein, and is not to be construed as an offer to sell or a solicitation to buy. Contact RBC Bearings for detailed information suitable to your specific applications. RBC Bearings reserves the right to modify its products and related product information at any time without prior notice.

Some of the products listed herein may be covered by one or more issued and pending U.S. or foreign patents. Contact RBC Bearings for product specific information.